

# WP361G monocrystalline silicon pressure transmitter

Apply to the measurement of flow, liquid level and pressure  
Adopt HART fieldbus technology, which can provide more field information  
to improve the performance of the factories.

## Product instruction

### WP361G series monocrystal silicon gauge pressure transmitter

- Adopt MEMS monocrystal silicon high-precision pressure sensor
- With high response speed and stability
- Measurement accuracy 0.075%FS
- The max. range ratio can reach to 100:1
- Adopt double overload protection technology
- With strong overload capability, the unidirectional pressure can reach to 20MPa
- Provide standard HART bus communication mode
- Sophisticated self-diagnosis and telecommunication function
- Highlighted LCD with backlight
- Local display screen which can rotate by 360°
- Convenient local zero clearing function
- Convenient local zero point, extreme point setting and calibration function
- Convenient local current loop calibration function

## Advanced manufacturing technique

The most reliable **quality experience**

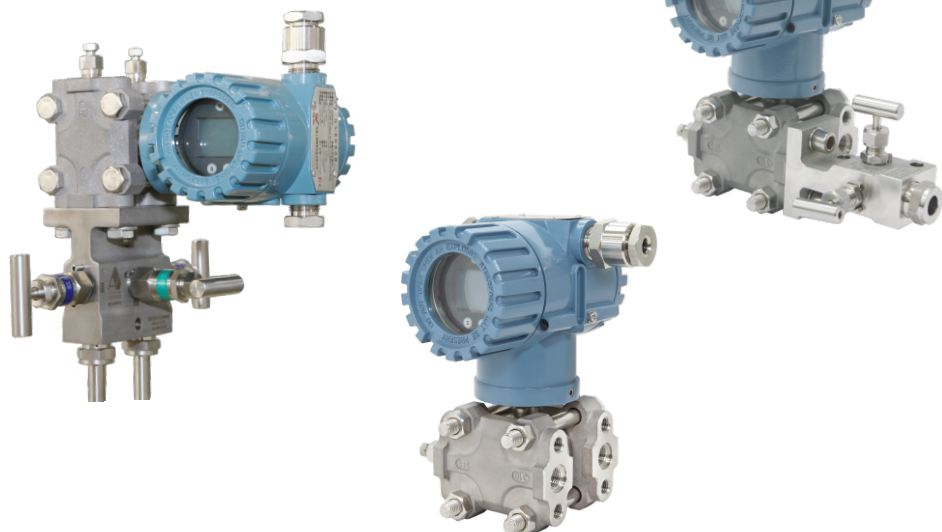

## Product Introduction

### Sensor membrane head

While working, the isolation diaphragms on the high/low-pressure sides and the filling liquids will transmit the process pressure to the membrane head of sensor and then converted into the corresponding current, voltage or digital HART® (high-speed addressable remote transmitter data highway) output signal.

WP361 series sensor can conduct temperature measurement to compensate the temperature effects.

In the characterization process of factory, all the sensors have gone through the pressure and temperature cycle test within the whole working range. The correction factors will be generated from these obtained data. Then the coefficients will be stored in the memory of intelligent board so as to ensure that the signal correction can be conducted precisely during the operational process of transmitter.

### Electronic circuit board

The electronic board adopts high-performance integrated circuit and surface packaging technology. This board will correct the input signal of sensor and then conduct linear treatment. The output part of electronic board module will convert the digital signal into analog output and conduct communication with the manipulator.

The liquid crystal header can display the pressure value, current value or the percentage of range.

### Data storage

The configuration data will be stored in the permanent EPROM storage of transmitter electronic board module. After the transmitter is power down, the data will be stored permanently. So after power on, the transmitter can work immediately.

### Digital/analog conversion and signal transmission

The process variable is stored in the form of digital data, which can be corrected accurately and conducted the conversion of engineering units. After correcting the signal, the data will be converted into analog output signal. HART manipulator can directly access to the reading of sensor in the way of data signal so as to get higher accuracy without digital/analog conversion.

### Communication format

WP361 series transmitter adopts HART protocol to conduct communication. This protocol adopts industrial standard Bell202 frequency shift keying (FSK) technology. The telecommunication can be conducted by overlaying high-frequency signal on the analog output. By using this technology, the communication and output can be realized simultaneously without influencing the integrity of loop. WP361 series transmitter can communicate with the host machine, which uses HART protocol.

### Software function

The users of HART protocol can easily use the functions of WP361 series, such as menu configuration, test and specific settings.

#### Configuration

By using HART manipulator, users can conveniently conduct current regulation, parameter configuration, HART information, two-point fine tuning and graphical monitoring on WP361 series menu, including:

- Zero and extreme point setting
- Engineering units selection
- Linear
- Damping time
- Display mode
- Display accuracy

HART information can input the informational data into the transmitter to identify and physically describe the transmitter, including:

- Date
- Station identification: within 8 characters
- Station description: within 16 characters
- Information: within 32 characters

#### Test

When the system goes wrong, if the operator confirms that the loop has faults, can let the transmitter provide specific output for loop tests.

#### Specific settings

In the initialization phase of transmitter and while maintaining the digital electronic board, specific settings should be conducted. It allows to conduct fine tuning on the sensor and analog output to accord with the pressure standard of the factory.

## Options

### Liquid crystal header

Digital header, 2-line 5-digit liquid crystal display

- Directly display the digital data, with higher accuracy
- Display the pressure, current or range percentage according to the requirements of users
- Can rotate by 360°, which is easy to install

### Transient voltage resistance protection

- Integrative transient voltage resistance protection terminal
- Electromagnetic compatibility accords with the national standard:

**IEC6100-4-2** Electrostatic discharge immunity test IIIB

**IEC6100-4-4** Electrical fast transient pulse clusters

anti-interference test IIIB

**IEC6100-4-5** Surge (shock) immunity test IIIB

# Specification

## Performance index

The overall performance is the composition error based on the reference accuracy, ambient temperature effects and range static-pressure effects.

### Accuracy index

±0.075%FS range

### Stability

≤±0.15%FS/5 years

## Concrete performance index

(Zero-base range, reference conditions, silicone oil filling liquid, 316 stainless steel isolation diaphragm, 4~20mA analog output, the digital fine-tuning value is equal to the set point value of range.)

### Accuracy

(The reference accuracy includes hysteresis, linear, setting ability and repeatability, which are based on terminal.)

±0.075% range

If the range is less than X

$$\pm [0.02 + 0.06 \frac{X}{\text{range}}] \%$$

X value:

Diaphragm capsule	XKPa
H	50
A	300
G	1000

## Damping time constant

The total damping time constant is equal to the sum of the damping time constants of amplifier unit and diaphragm capsule. The damping time constant of amplifier unit is adjustable within the range of 0~100s.

Diaphragm capsule (silicone oil)

Time constant (s) (The time constant can be set according to the actual situation of field and is recommended 1S)

## Influence of installation position

The changing of installation position, which is parallel to the surface of diaphragm, will not cause the effect of null shift. If the change between the installation position and the surface of diaphragm do not exceed 90°, the null shift within 0.4KPa can be corrected by zero setting without influencing the range.

## Influence of power supply

Less than ±0.005% range/v

## Functional parameter

The limit value of range and sensor

Table 1: Range of WP361G transmitter and limit value of sensor

Range	Min. range	Upper limit of range (URL)
M	6KPa	40KPa
H	2.5KPa	250KPa
V	10KPa	1MPa
A	0.03MPa	3MPa
G	0.1MPa	10MPa

## Zero point and range adjustment requirements

- The zero point and range can be adjusted arbitrarily within the range limit value indicated in Table 1.
- The range should be larger than or equal to the min. range indicated in Table 1.

## Applications

Measurement of liquid, gas and steam

## Output

Two-wire 4-20mA, linear output is selectable for users. Digital process variable overlays on the 4-20mA signal, which can be applied to the host machines according with HART protocol.

## Power supply

Need external power supply. While standard transmitter (4-20mA) has no load, work at 14.5-45V DC.

### Loop load limit

The max. loop resistance is decided by the voltage of external power supply, the relations are as follows:

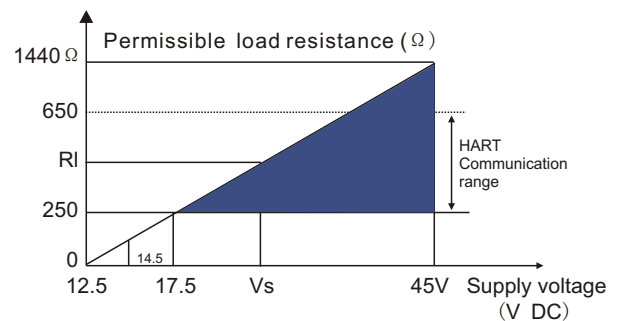

Supply voltage - load characteristic relation scheme

Note: The supply voltage range of transmitter with backlight display is 14.5~45V

The supply voltage range of intrinsic-safety series transmitter is 14.5~28V.

The working voltage while HART communication should be larger than 17.5V.

### Max. overpressure

H: 10MPa  
 A: 10MPa  
 G: 20MPa

### Fault mode

#### Output code

While discovering the faults of sensor or microprocessor by self diagnosis, the transmitter will output one high or low alarm signal to prompt the users. The alarm output value is subject to the factory configuration mode of transmitter:

Linear output:  $3.8 < I < 20.8$   
 C4: I=20.8mA high fault  
 CN: I=3.8mA low fault

### Temperature limit

#### Environment

-20°C ~ +70°C

#### Storage

-46°C ~ 110°C

With header: -40°C ~ 85°C

#### Process

Larger than or equal to the atmosphere, please see the following table

Table 2: Process temperature limit of WP361G transmitter

Silicone oil filled sensor	-40 to 121°C
Inertia liquid filled sensor	-30 to 121°C

### Temperature drift

≤ 0.075%FS/10°C

### Humidity limit

0-100% relative humidity

### Starting time

Reach to the performance index within 2s after the transmitter is power up.

### Mechanical performance index

#### Electrical interface

ANSI(American-Standard) NPT1/2(F) internal thread  
 ISO (Chinese standard) M20×1.5 internal thread

#### Process interface

No process interface (NPT1/4 internal thread on the chamber flange)

With waist-shaped interface: NPT1/2 taper pipe internal thread

With T-shaped interface: M20×1.5 external thread and back welding connecting pipe (stainless steel)

With waist-shaped interface matching used with NPT1/2

pressure-leading transition head and back welding connecting pipe (stainless steel)

#### Process liquid-contacting piece

Process isolation diaphragm: 316 stainless steel, hastelloy C

#### Drain/vent valve

316 stainless steel

#### Process flange and interface

Carbon steel cadmium plate, 316 stainless steel

#### Non-liquid-contacting piece

##### Shell

Aluminium die casting IP65

##### Coating

Spraying plastics

##### Meter cap O-ring

Nitrile rubber

### Wiring diagram of terminal side

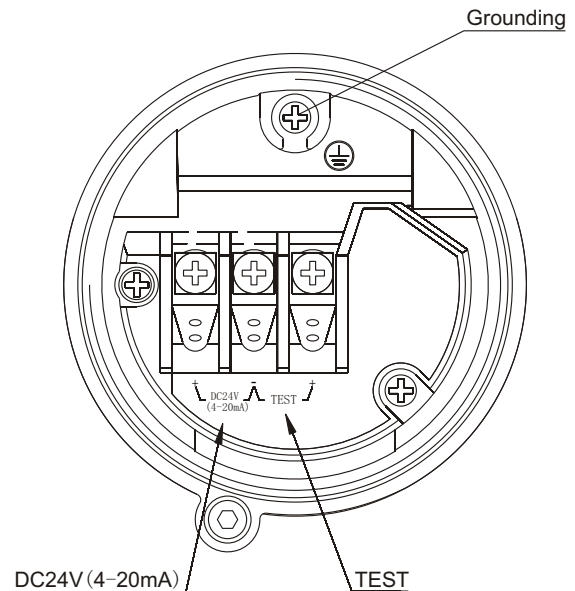

Connecting terminal	
DC24V(4~20mA) $\begin{matrix} + \\ - \end{matrix}$	Power supply and output end
TEST $\begin{matrix} + \\ - \end{matrix}$	Connect to the testing terminal of ampere meter (impedance should be less than 10 Ω)
$\begin{matrix} \oplus \\ \text{---} \\ \text{---} \end{matrix}$	Ground terminal

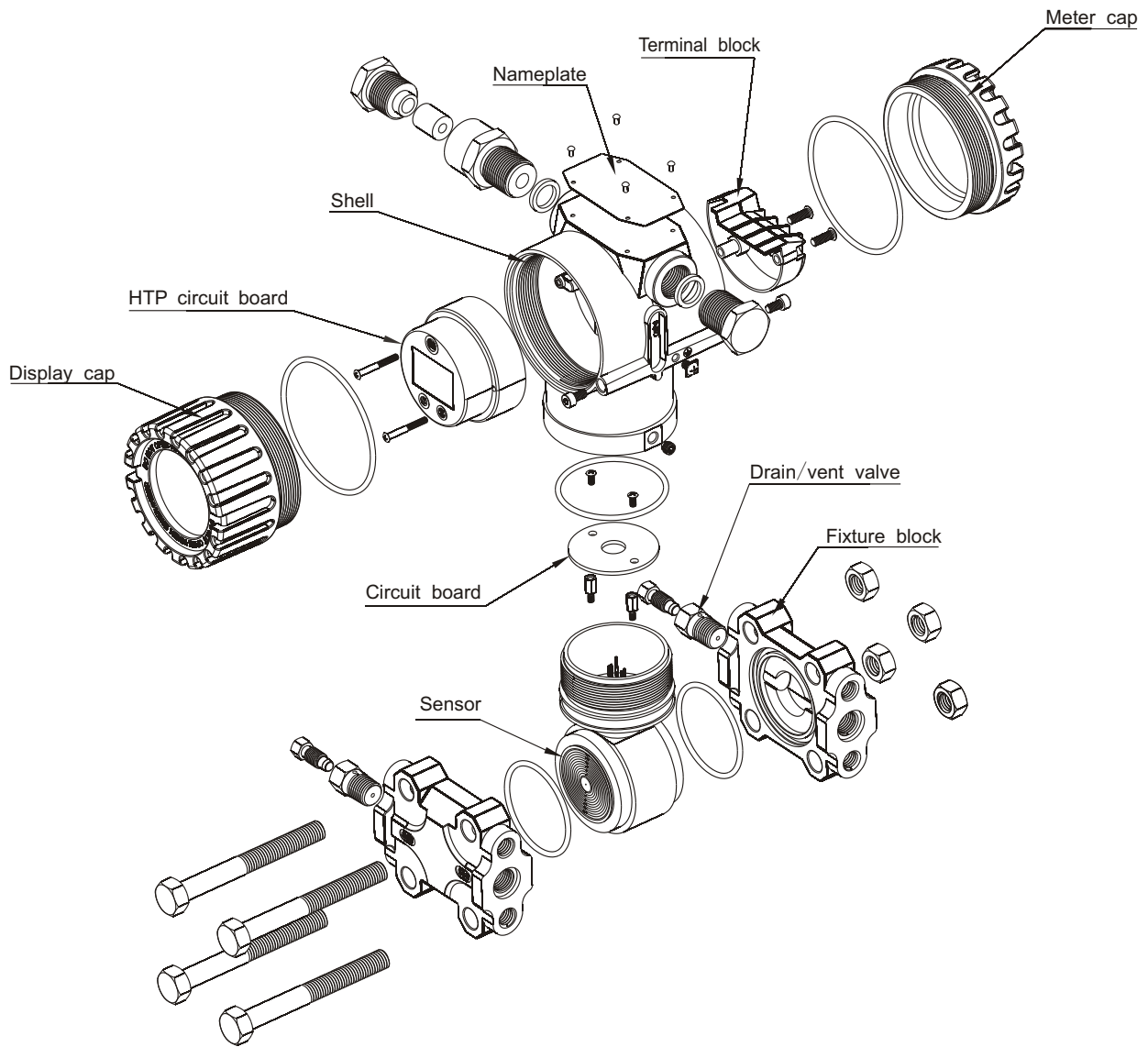
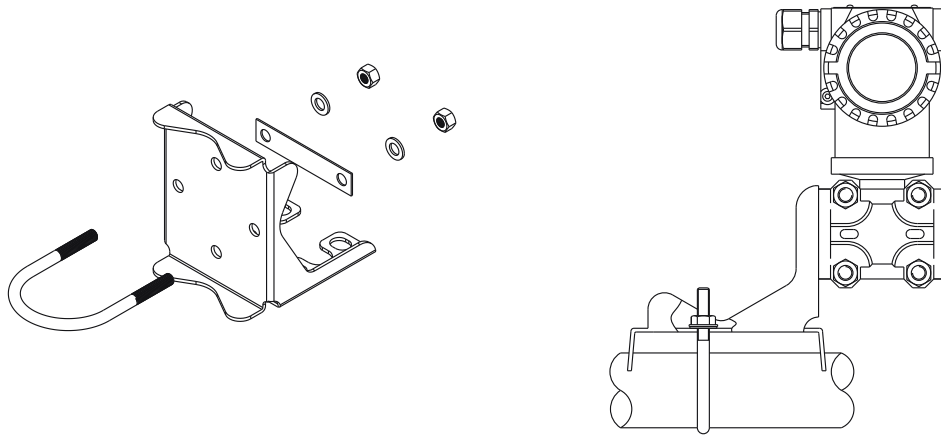
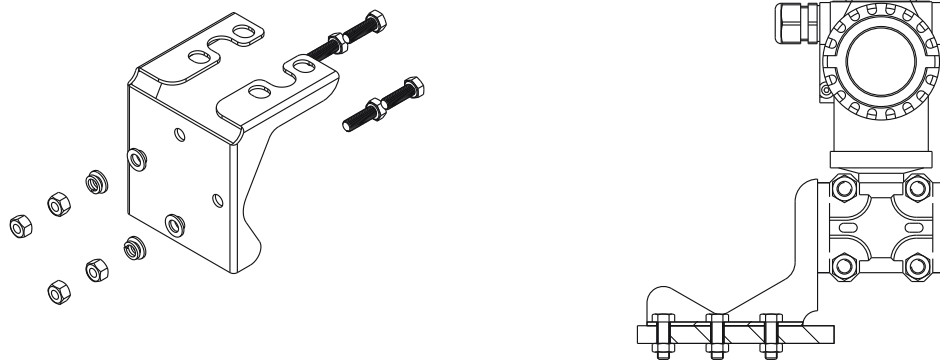

Fig. 3 Parts breakdown drawing of WP361G monocrystalline silicon pressure transmitter



Pipe installation (Code of this option: B1)



Panel mounting (Code of this option: B2)

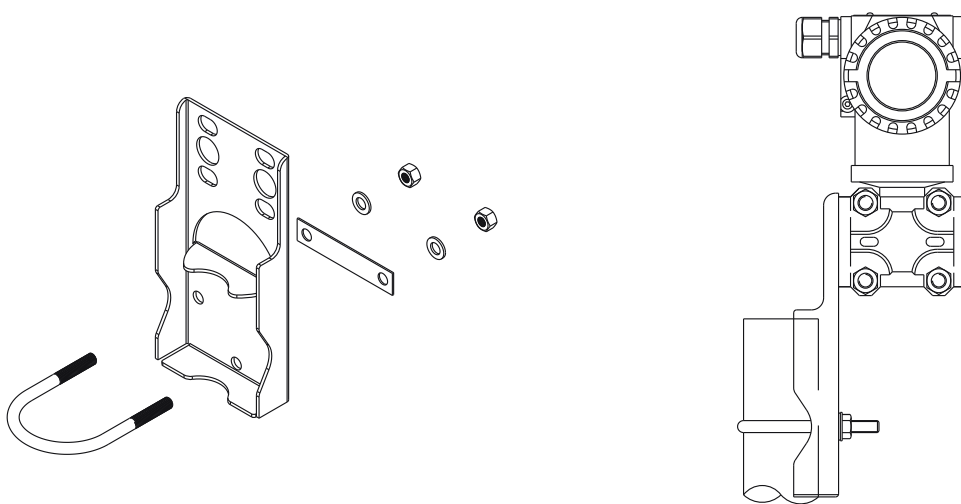

Pipe installation (Code of this option: B3)

Fig. 4: Installation structure, with optional bracket, applied to 2 inch pipe or panel installation

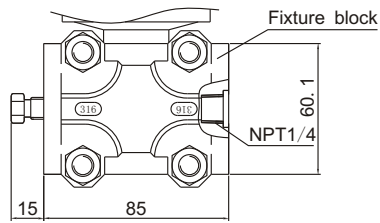

P-No process interface (chamber flange)  
NPT1/4 internal thread)

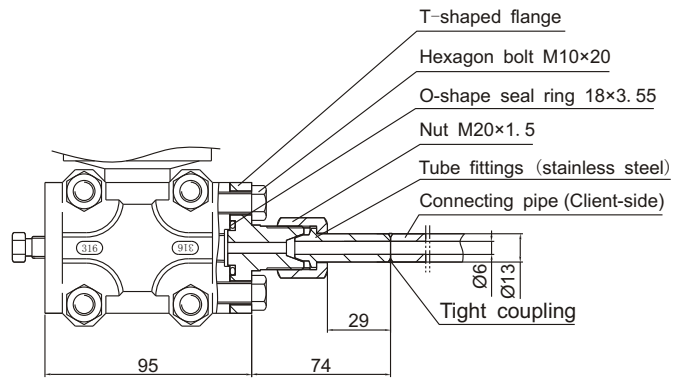

J-with T-shaped interface: M20×1.5 external thread  
and back welding connecting pipe (stainless steel)

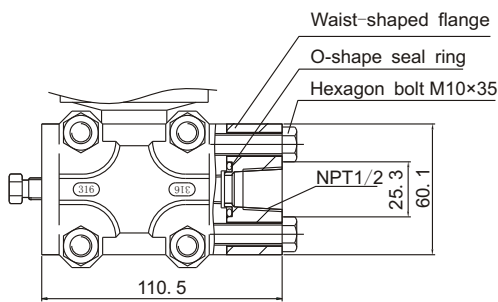

N-with waist-shaped interface: NPT1/2  
taper pipe internal thread

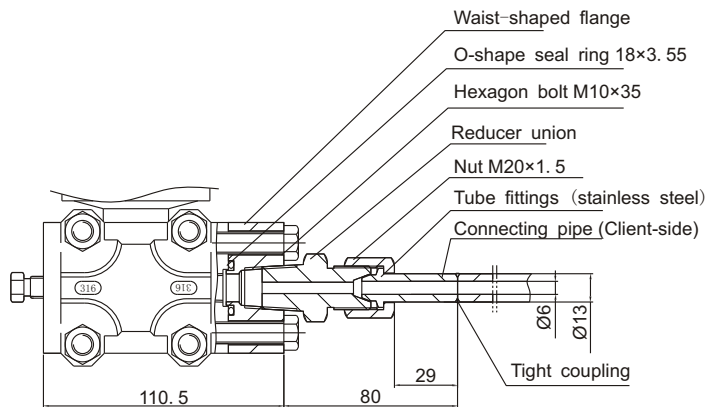

C-with waist-shaped interface: NPT1/2 pressure-leading  
transition head and back welding connecting pipe (stainless steel)

Fig. 5: Process connecting type

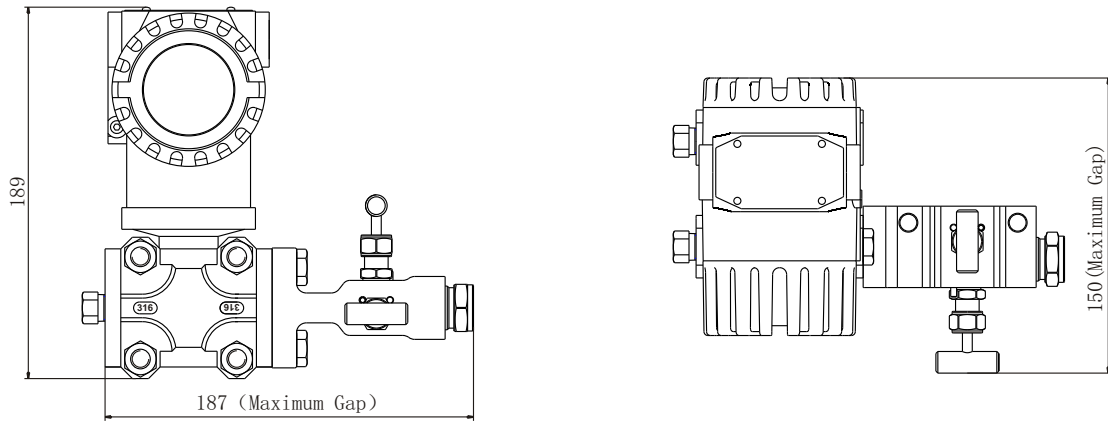

Component dimension figure of two valve group

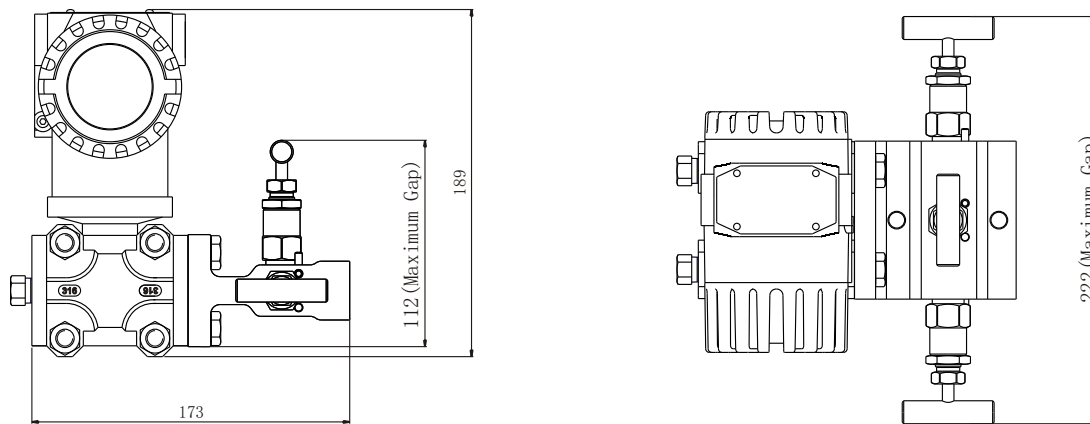
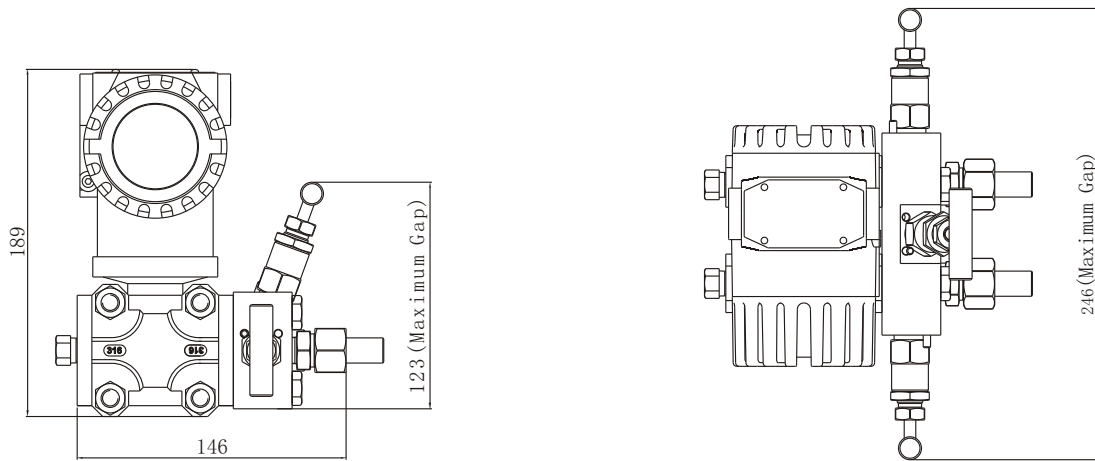

Component dimension figure of three valve group

Fig. 6: Component dimension figure of integrated valve group (unit: mm)



Table 3: WP361G monocrystalline silicon pressure transmitter

Model	Transmitter type	
WP361G-	Monocrystalline silicon pressure transmitter	
Code	Measurement range of pressure	Overload
M	0-6~40Kpa	10MPa
H	0-2.5~250KPa	10MPa
V	0-0-10~1000KPa	10MPa
A	0-0.03~3MPa	15MPa
G	0-0.1~10MPa	20MPa
Code	Filling liquid	Diaphragm material
1	Silicone oil	316L stainless steel
2	Fluorocarbon oil	316L stainless steel
3	Silicone oil	Hastelloy C
4	Fluorocarbon oil	Hastelloy C
5	Silicone oil	Ta diaphragm
6	Fluorocarbon oil	Ta diaphragm
Code	Electrical interface	
A	NPT1/2 internal thread	
M	M20×1.5 internal thread	
Code	Header	
-M	LCD display	
-N	No header	
Code	Options for the hazardous occasion certification	
N	Ordinary type (no anti-explosion)	
D	Flame-proof Exd II CT6	
I	Intrinsic-safety type Exia II CT6	
Code	Mounting bracket	
B3	Pipe-mounted flat bracket (2" pipe)	
B1	Pipe-mounted bent bracket (2" pipe)	
B2	Plate-mounted bent bracket	
Code	Process connection type	
P	No process joint (NPT1/4 internal thread on chamber flange)	
J	With "T" shaped joint; M20×1.5 external thread and rear welded pressure tube	
N	With "Waist" shaped joint: NPT1/2 conical internal thread	
C	With "Waist" shaped joint with NPT1/2 pressure transition head and rear welded pressure tube	
Code	Integrated valve assembly option(optional)	
V2	Two valves manifold	
Code	Other option	
H	The measurement accuracy is 0.075%FS	
S	The liquid material is 316 stainless steel	
D0	The discharge valve is at the rear end face of the clamp block	
D1	Clamp block side drain valve in upper	
D2	Clamp block side drain valve in lower part	
Q4	Verification certificate(Contact Wide Plus)	
C4	High alarm	
CN	Low alarm (The default setting is low alarm)	
Y	Special requirements	
Example	WP361G-H1A-MDB3ND0	

Note: 1, "Valve group integrated installation option" can be selected or not, the standard is provided for 316 material, if you have other requirements can contact our company  
 When "Valve Group Integrated Installation Option" is selected, the process connection type can only be P: no process connection  
 2, The default contact liquid material is 304 stainless steel.