

WP-302 two-wire system intelligent temperature transmitter

—WP-302A/B, WP-302A/B2 and WP-302A/B3

Working principle

The temperature of the industrial field can be inputted into WP-302X by thermal resistance or thermocouple transducer and then converted into the corresponding digital quantity by microprocessor after “analog-digital conversion”. Then the digital quantity will be converted into the corresponding 4-20mA signal output and, at the same time, transmitted to the highlighted LCD real-time display according to the proportion through “digital-analog conversion”. The processor can monitor the sensor states simultaneously. Both the short-circuit and open-circuit faults can be fed back to the main control unit (MCU) via 4-20mA signal. Besides, the system faults of the transmitter can be confirmed by the set current value (see the operating manual or technical parameters for details).

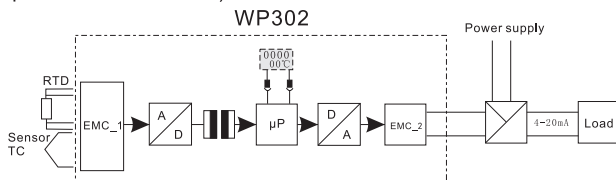

Characteristics

- The two-wire system transmitter, which is based on current loop power supply, can effectively reduce the wiring costs and power consumption and enhance the anti-interference ability.
- 4-20mA output with multiple fault message feedback abilities.
- While connecting to the thermal resistance transducer, it has short-circuit and open-circuit monitoring function; while connecting to the thermocouple transducer, it has open-circuit monitoring function.
- By using the 3 built-in operating buttons together with the highlighted LCD display, the parameters of the transmitter can be set locally conveniently.
- The rotatable LCD display enhances the flexibility of transmitter installation and displays the percentage of current measured value in the full scale, current measured value and its unit and the sensor type and the diagnostic messages of transmitter etc.
- The protection level of shell is IP67, which can be applied to the outdoor usage.
- Support all the transducers conforming to IEC751 and IEC584.

Application

- Metallurgical and steel industry
- Petrochemical industry
- Machine manufacturing industry
- Food and beverage industry
- Municipal water and sewage treatment industry
- Little textile/sugaring/papermaking/glass and other industries

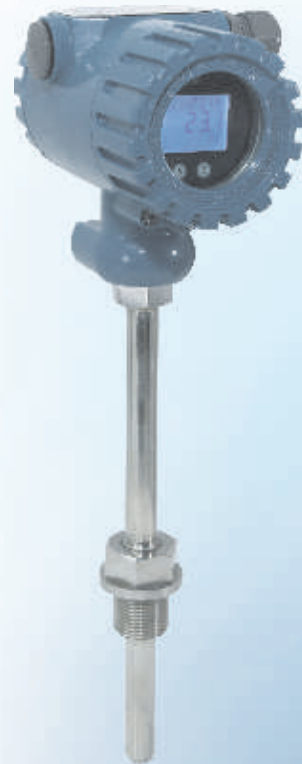

The most reliable **quality experience**
Advanced manufacturing technique

Technical parameters

Input

Sensor type:

WP-302A/B1: Pt100, Pt1000, Cu50, Cu100

WP-302A/B2: S, R, B, K, N, E, J, T, WRe3-25

WP-302A/B3: Pt100, Pt1000, Cu50, Cu100

S, R, B, K, N, E, J, T, WRe3-25

Accept the user's designation

Connection modes

WP-302A/B1: A two/three/four-wire system thermal resistance transducer

WP-302A/B2: A thermocouple transducer and a thermal resistance transducer (three-wire) can work as the cold junction compensation or set the fixed cold-junction temperature to compensate without connecting to the thermal resistance transducer, or use the built-in thermal resistance transducer of the transmitter to conduct cold junction compensation (The compensation precision will effect the final measurement accuracy.)

WP-302A/B3: adopt the connection mode of WP302A/B1 or WP302A/B2 according to the needs

Measurement range

Appendix 1: List for the inputted sensor types and accuracies

Response time

≤250ms with sensor short-circuit and open-circuit monitoring

Output

Two-wire system 4-20mA

Load resistance Ra

$R_a \leq (U_s - 14.7V) / 0.024A$, U_s is the loop voltage

Sensor faults

Short circuit: accept the user's designation (3.5~3.75mA)

Open circuit: accept the user's designation (21~23mA)

System faults

Can be set as 3.2mA or 24mA

Measurement accuracy

Accuracy (Digital measurement accuracy)

See appendix 1: List for the inputted sensor types and accuracies

Analog output accuracy

0.025% full scale

Long term drift

The first year <0.2% full scale

Temperature effects

See appendix 2: Effects of ambient temperature

Power supply effects

<0.001% full scale/V

Load impedance effects

<0.025% full scale/100Ω

Rated operating conditions

Ambient temperature

-40~85℃ -20~60℃ (Anti-explosion type)

Condensation

Allowable

Electromagnetic compatibility

GB/T 17626, Grade 3

Protection grade according to EN 60529

IP67

Design

Shell

Aluminium die casting

Weight

1kg (not including temperature sensor)

Size

See Appendix 3: Dimensional drawing for two-wire system intelligent temperature transmitter

Cable sealed tube connecting thread

M20×1.5 other threads need to use adapters

Connection of sensor

Integrated type

split type

Display and control

Size of display

33×23mm

Display precision

5 digits

Unit (Switchable)

℃ or ℉

Settings

The 3 buttons of the panel

Power supply

15~36V DC

Electric isolation

Between the input and output $U_{eff} = 1 \text{ kV}$, 50 Hz, 1 min

Certificate and licence

Flame-proof type

Exd II CT6

Intrinsic safety type

Exia II CT6

Default setting of transmitter

Sensor

Pt100 or B type thermocouple or designated by the customer

Sensor migration

0℃

Damp

0.0S

Wiring diagram for the transmitter

Wiring diagram for the integrated type transmitter

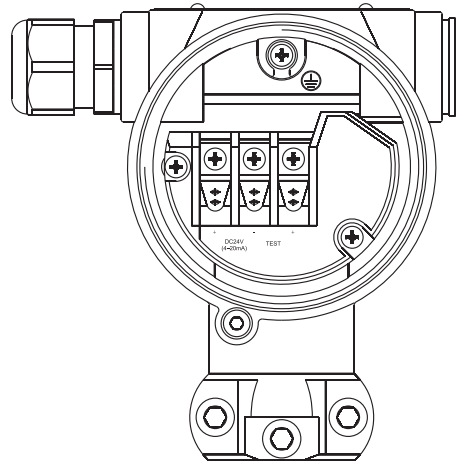

Wiring diagram for the split type transmitter

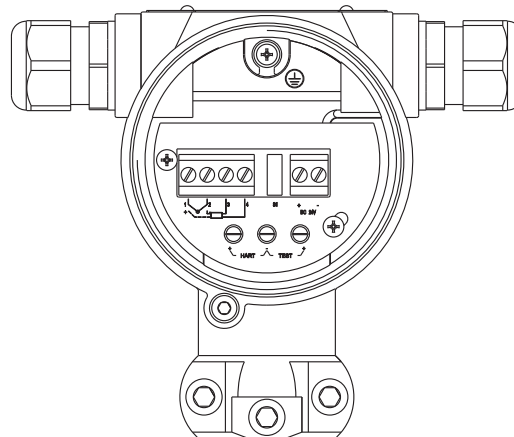

Structure diagram for WP-302 two-wire system HART intelligent temperature transmitter

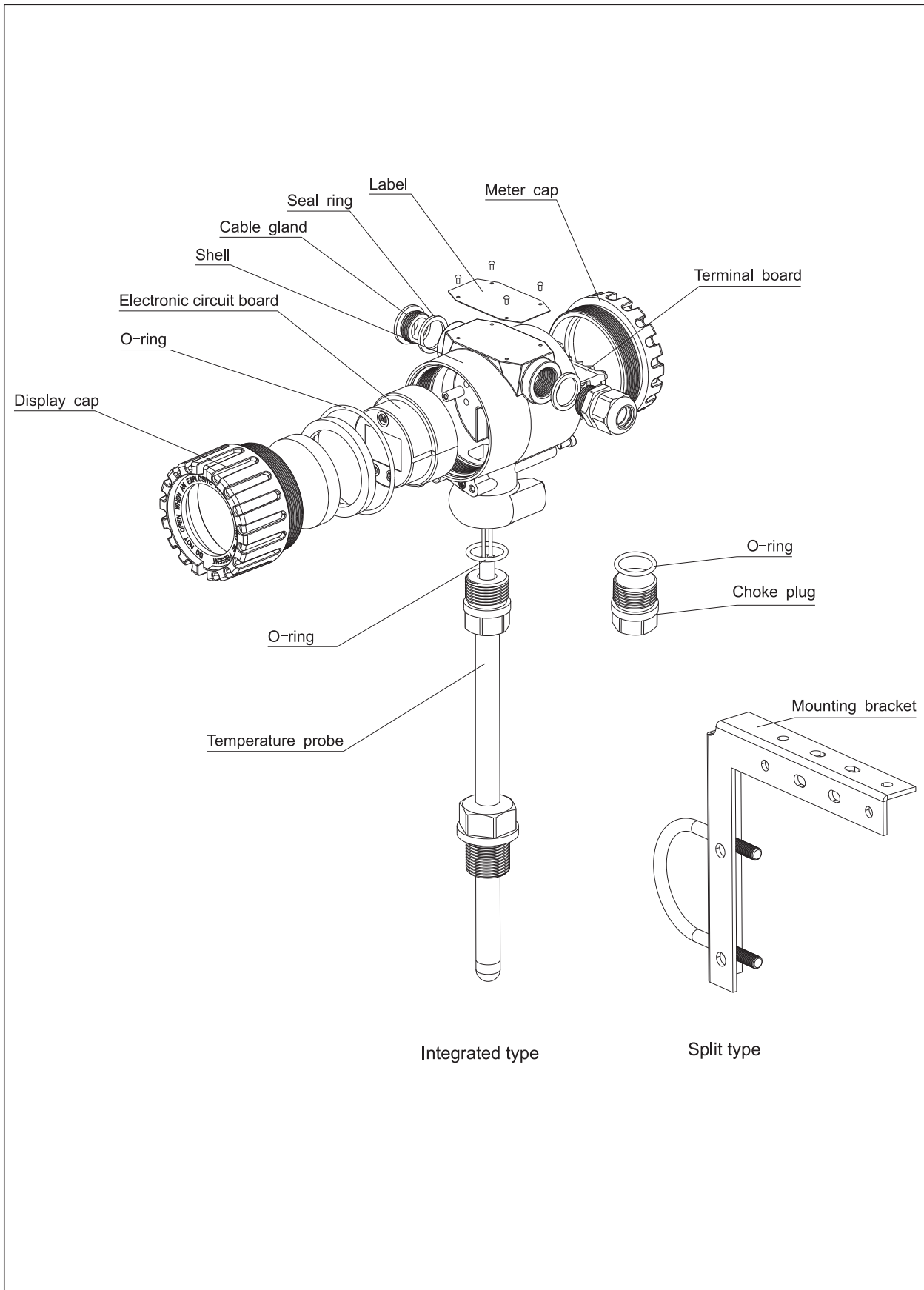

Type spectrum table for WP-302 two-wire system HART intelligent temperature transmitter

Model	Product description
WP-302	Two-wire system intelligent temperature transmitter
Code	Display header
A	Integrated type (with temperature sensor, see the spectrum table for temperature sensor in Page 28 and 29 for details)
B	Split type (without temperature sensor, can be connected to any temperature sensor)
Code	Sensor type
1	Thermal resistance (The corresponding codes of sensor model are 01~04, 14.)
2	Thermocouple (The corresponding codes of sensor model are 05~13, 14.)
3	Full input (thermal resistance or thermocouple, the corresponding codes of sensor model are 01~14.)
Code	Sensor model ^①
01	Pt100
02	Pt1000
03	Cu50
04	Cu100
05	B
06	E
07	J
08	K
09	N
10	R
11	S
12	T
13	WRe3-25
14	Designated by user
Code	Anti-explosion grade
S	Standard type
D	Flame-proof type Exd II CT6
I	Intrinsic safety type Exia II CT6
Code	Range ^①
1	The default range: thermal resistance and full input model are Pt100:0~100℃; for thermocouple model, see (Appendix 1: List for the inputted sensor types and accuracies)
2	User-defined
Code	Electrical interface
1	M20×1.5
2	1/2NPT
Code	Range ability ^①
	Filled by the users (For example: -200℃~850℃), when the sensor model is designated by users, The writing form is: "Sensor model: range" For instance: Pt100: -200℃~850℃.
*See the sensor type spectrum table for the model of sensor	
Example	
WP-302A1-01I2(-200℃~850℃)	
It means the integrated type two-wire system intelligent temperature transmitter, with user-defined range -200℃~850℃. The matched sensor is Pt100 thermal resistance and the anti-explosion grade is intrinsic safety type Exia II CT6.	

*Note:

① WP-302 series has covered the sensors (model: 01~13). While the users designating the sensor type and range ability, it only directs at the default configuration when leaving the factory.