



Y.LIN ELECTRONICS CO.,LTD.

Data Sheet

Customer: _____
Part No: _____ YRMC2C12-H1 _____
Sample No: _____
Description: _____ Receiver module _____
Item No: _____

Customer			
Check	Inspection	Approval	Date

Y.LIN			
Drawn	Check	Approval	Date
			2021/4/21

Mainland address: Jinhe The Third Industrial Zone, Zhangmutou Town, Dongguan, Guangdong, China

H.K address: Unit 503 5/F, Silvercord Tower 230 Canton Road Tsimshatsui

TEL: 0769-87181888 FAX: 0769-87187333 E-mail: ylin06@y-lin.com [Http://www.yong-lin.net](http://www.yong-lin.net)



Features:

- Wide Operating Supply Voltage 2.7V~5.5V
- Internal voltage reference circuit for wide operating built-in.
- Maximum interference safety against external light sources
- No external components necessary.
- The Center Frequency can be varied with option PADs (36.0kHz,37.9kHz,40.0kHz,56.7kHz)
- Internal filter for a high frequency lighting fluorescent lamp.
- Built-in automatic bias control for sunlight.
- Output active low.

Applications

- Wireless remote control for TV, air conditioning, set-top box, fan and so on
- Wireless remote control, such as audio, toy, etc.
- Reflective sensors for hand dryers, water faucets, toilet flush
- Safety door detection, vending machine fall detection

Description

- This infrared receiver module is miniaturized infrared receivers for remote control and other applications requiring improved ambient light rejection
- The separate PIN diode and preamplifier IC are assembled on a single leadframe.
- The epoxy package contains a special IR filter.
- This module has excellent performance even in disturbed ambient light applications and provides protection against uncontrolled output pulses.



Package Dimensions in millimeters

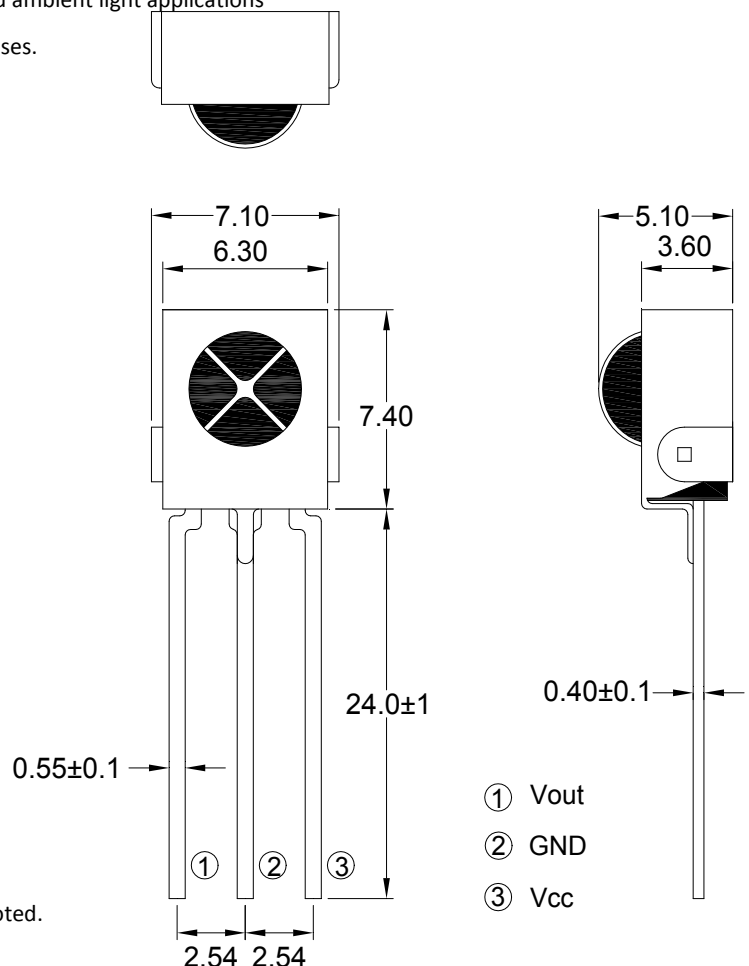

Notes:

1. All dimensions are in millimeters.
2. All dimension tolerance is ±0.25mm unless otherwise noted.
3. Specifications are subject to change without notice



YRMC2C12-H1

Selection Guide

Part No.	Carrier frequency	Lens Type
YRMC2C12-H1	38khz	Black

Electrical And Optical Characteristics (Ta=25°C)

Parameter	Symbol	Min	Typ.	Max	Units	Condition
Supply Voltage	Vcc	2.7	-	5.5	V	
Static Current	Icc	-	0.9	1.5	mA	Under no signal
Peak Wavelength	λ_p	-	940	-	nm	
B.P.F Center Frequency	f ₀	-	38	-	KHz	
Reception Distance	L ₀ ($\theta=0$)	15	20	-	m	IF=200mA Vcc=5V
Half Angle	ϕ 1/2	-	±45	-	deg	Angle of half transmission distance
High Level Output Voltage	V _{oh}	Vcc-0.3	-	-	V	
Low level output voltage	V _{ol}	-	0.2	0.4	V	
High Level Pulse Width	T _{wl}	500	600	800	μs	Fin=f ₀ , burst wave Vin=600us
Low Level Pulse Width	T _{wh}	500	600	800	μs	

Absolute Maximum Ratings (Ta=25°C)

Parameter	Symbol	Ratings	Units	Notice
Supply Voltage	Vcc	6.0	V	--
Output Voltage	Vout	6.0	V	--
Operating Temperature	T _{opr}	-25~+85	°C	--
Storage Temperature	T _{stg}	-40~+125	°C	--
Soldering Temperature	T _{sd}	260	°C	2mm from mold body less than 5 sec

Acceptable code list

data format	code acceptable
NEC	√
RC5_Philips	√
RC6_Philips	×
RCA_Thomson	×
Toshiba	√
Sharp	√
Sony 12 Bit	√
Sony 15 Bit	√
Sony 20 Bit	×
Matsushita	√
Mitsubishi	√
Zenith	√
JVC	√
Continuous code	×
High Data Rate code	×

Suitable data format

Item	Symbol	limitation
Minimum Burst Length t_{burst} (number of pulses per burst)	t_{Burst}	10pulses
Minimum Burst Gap time t_{burst_gap} (number of pulses per burst) between two burst	t_{Gap}	14pulses
Minimum data pause time	t_{Pause_min}	25ms

Fig 1. The diagram of min. burst length, min burst gap, data pause time

< Figure1, Typical IR signal >

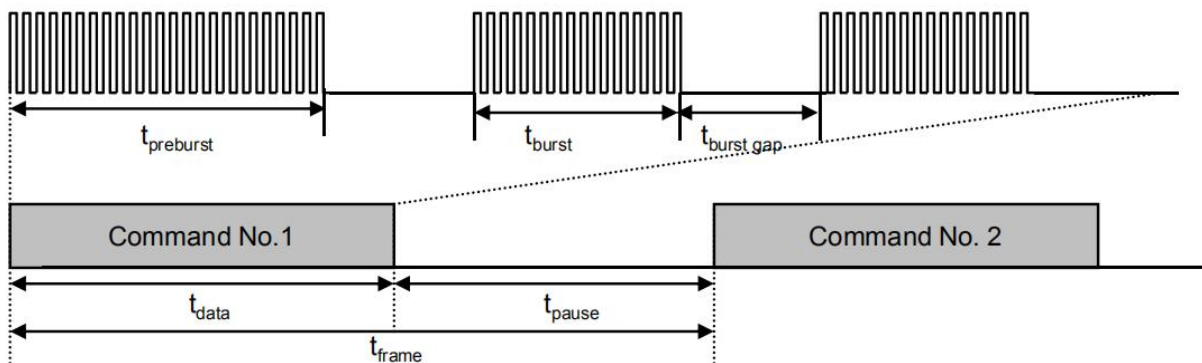

$$t_{actual_data} = t_{preburst} + \sum_n t_{burst} \quad , \quad t_{actual_gap} = t_{pause} + \sum_n (t_{burst_gap})$$

$$t_{actual_gap} \geq 2.0 * t_{actual_data} \quad (1)$$

Test Method

A. Standard Transmitter

Transmitter Output

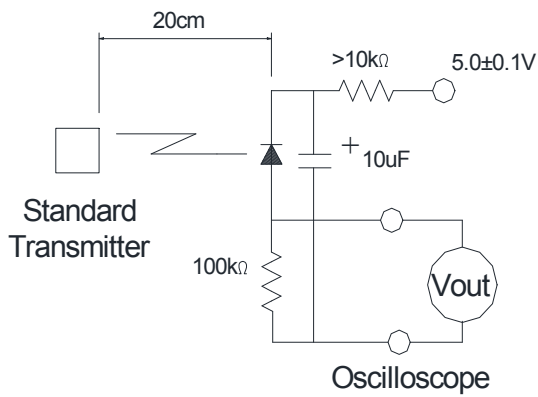
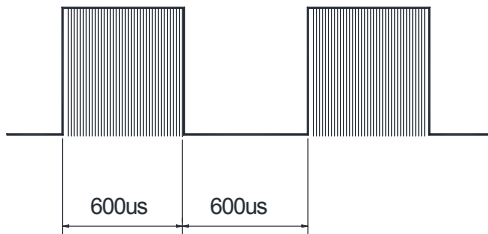

B. Detection Length Test

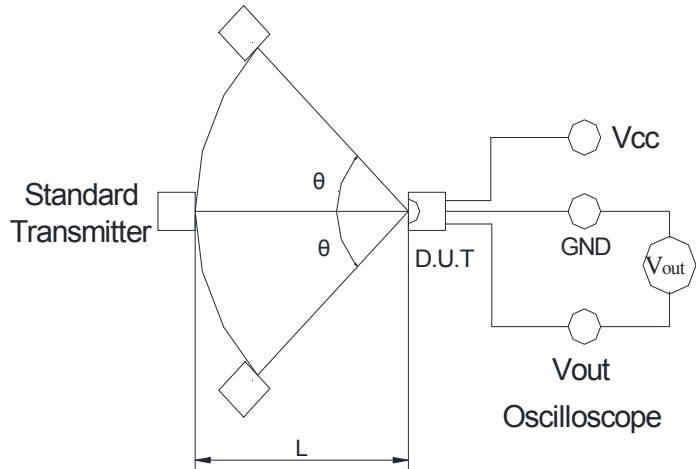

C. Pulse Width Test

Transmitter Output

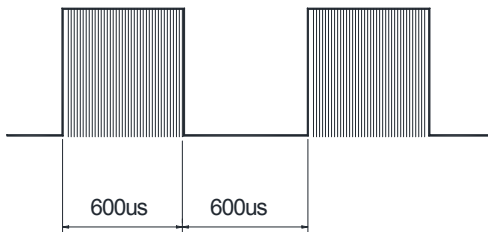

D.U.T Output Pulse

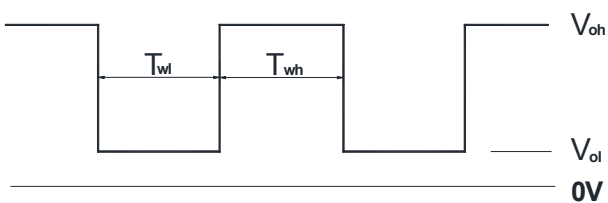



Block Diagram

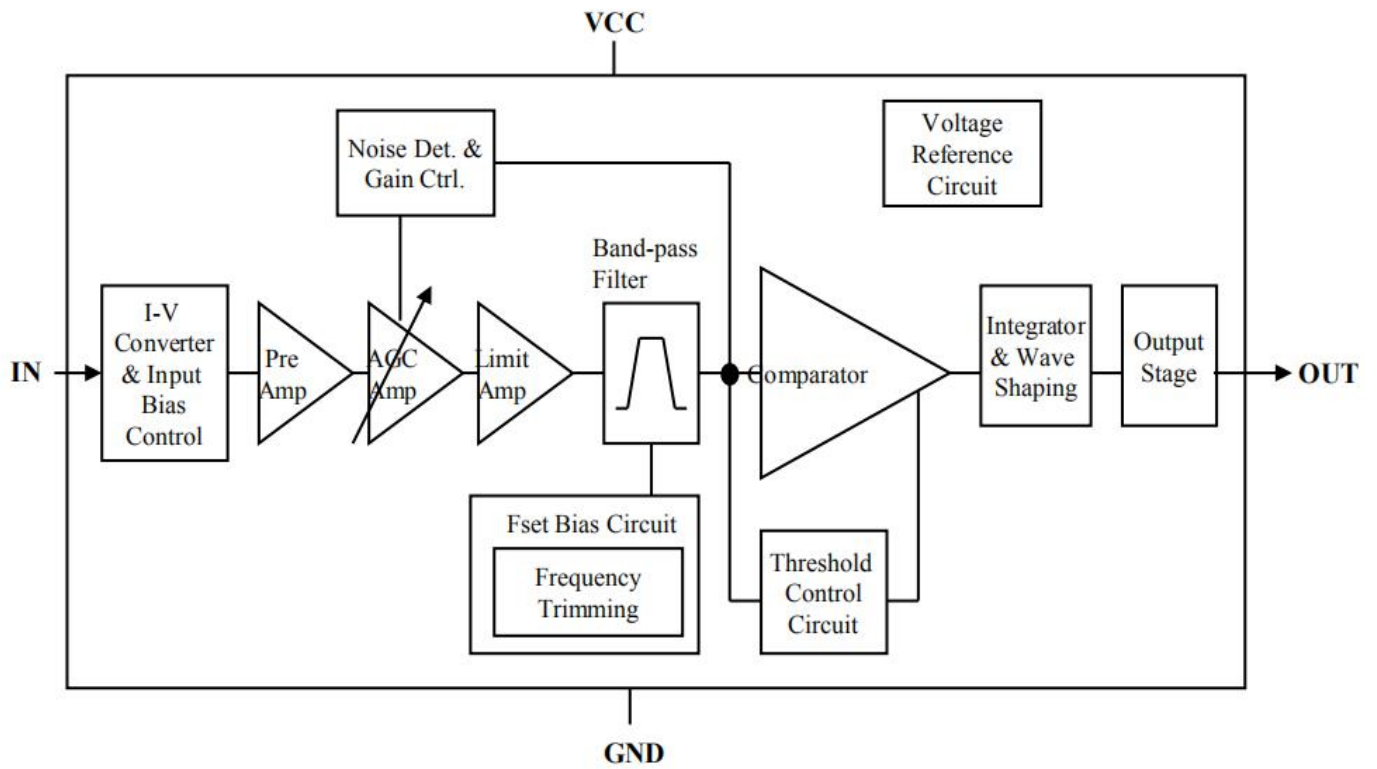

Application Circuit

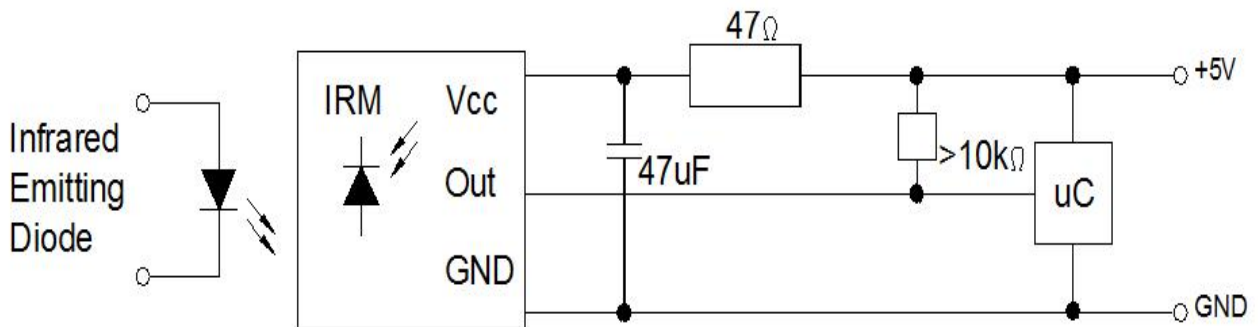



Characteristic Curves (Ta=25°C)

Fig.1 Relative Supply Current Vs Supply Voltage

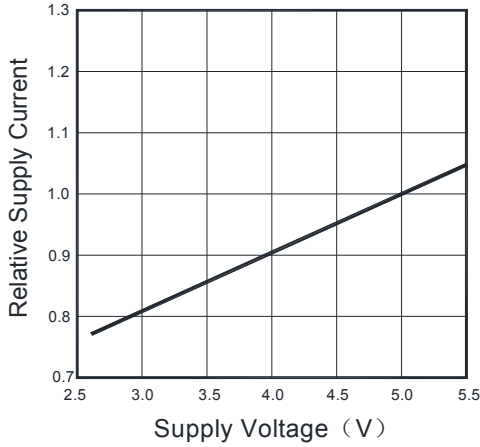

Fig.2 Relative Supply Current Vs Ambient Temperature

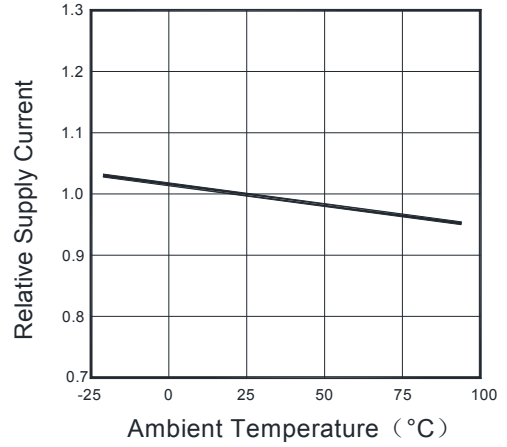

Fig. 3 - Relative sensitivity VS Relative Frequency

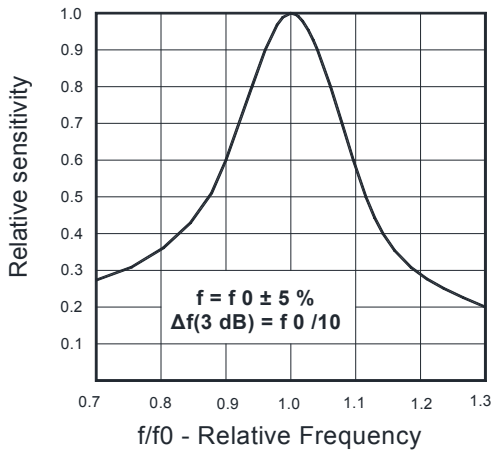

Fig.4 Relative Photo current Vs Irradiance

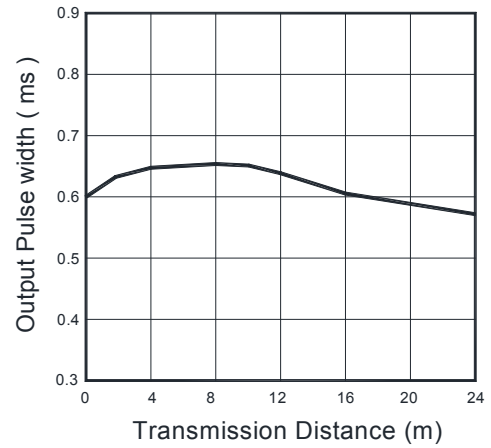

Fig.5 - Relative Sensitivity vs Sensitivity angle

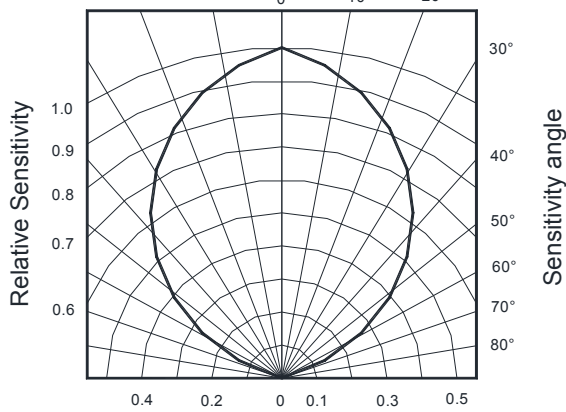
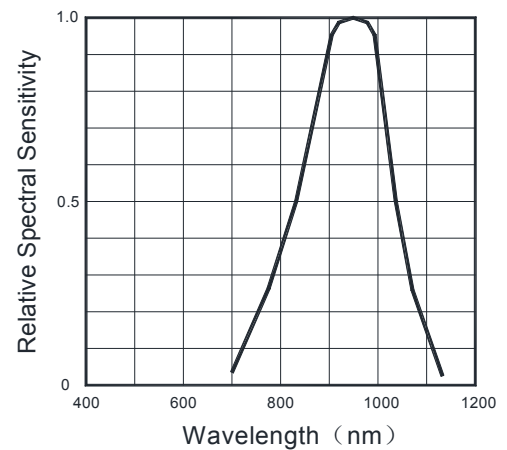

Fig.6 Relative Spectral Sensitivity vs Wavelength





YRMC2C12-H1

Reliability Test Item And Condition

Test Item	Test Condition	Ref.Standard	Time	Quantity	Ac/Re
Life Test	Ta=25°C±5°C IF=20mA	JESD22-A108	1000H	22Pcs	0/1
Temperature cycle	100°C±5°C 30 min. ↑↓5 min -40°C±5°C 30 min.	JEITA ED-4701 100 105	100 Cycles	22Pcs	0/1
High Temperature Storage	Ta=100±5°C	JEITA ED-4701 200 201	1000H	22Pcs	0/1
Low Temperature Storage	Ta=-40±5°C	JEITA ED-4701 200 202	1000H	22Pcs	0/1
Storage at High Temperature/High Humidity	Ta:85±5°C ,RH:85±5%	JEITA ED-4701 100 103	1000H	22Pcs	0/1
Soldering resistance	Tsol=260±5°C 10s	JEITA ED-4701 300 302	1 times	22Pcs	0/1
Solderability	Tsol=235±5°C 5s	JEITA ED-4701 300 303	1 times	22Pcs	0/1

Criteria For Judging Damage

Test Items	Symbol	Test conditions	Criteria For Judgement	
			Min.	Max.
Forward Voltage	VF	IF=20mA		U.S.L*)x1.1
Reverse Current	IR	VR = 5V		U.S.L*)x2.0
Luminous intensity	IV	IF=20mA	L.S.L*)x0.7	

U.S.L: Upper standard level

L.S.L: Lower standard level

The technical information shown in the data sheets are limited to the typical characteristics and circuit examples of the referenced products.It does not constitute the warranting of industrial property nor the granting of any license.



1.Storage time

LED can be stored for a year under the condition:the temperature of 5°C-28°C and humility of RH60%,These production must be re-inspected and tested before use if their storage time exceed three months.

2.ESD countermeasure

Static electricity and high volt can damage LED,The production whose Die material is InGa must strictly required to prevent ESD,must put on static glove and static fillet,Soldering tool and the cover of device must connect the ground, soldering condition follows the related stating of production specification manual.

3.Soldering

When soldering leave a minimum of 2mm clearance from the base of the lens to the soldering point.

Dipping the lens into the solder must be avoided.

Do not apply any external stress to the lead frame during soldering while the LED is at high temperature.

Recommended soldering conditions:

Soldering iron		Wave soldering	
Temperature	320°C Max	Pre-heat Pre-heat time	120°C Max 120 sec.Max
Soldering time	3 sec.Max (one time only)	Solder wave Soldering time	260°C Max 5 sec.Max

Note: Excessive soldering temperature and/or time might result in deformation of the LED lens or catastrophic failure of the LED.

4.CAUTION (When use and storage of this device)

- 1.Store and use where there is no force causing transformation or change in quality .
- 2.Store and use where there is no corrosive gas or sea(salt) breeze .
- 3.Store and use where there is no extreme humidity .
- 4.Put decoupling device between Vcc and GND for reduce the noise from power supply line .
- 5.The performance of remote-control system depends on environments condition and ability of periferal parts. Customer should evaluate the performance as total system in those conditions after system up with components such as commander , micon and this receiver module .



Soldering temperature curve chart

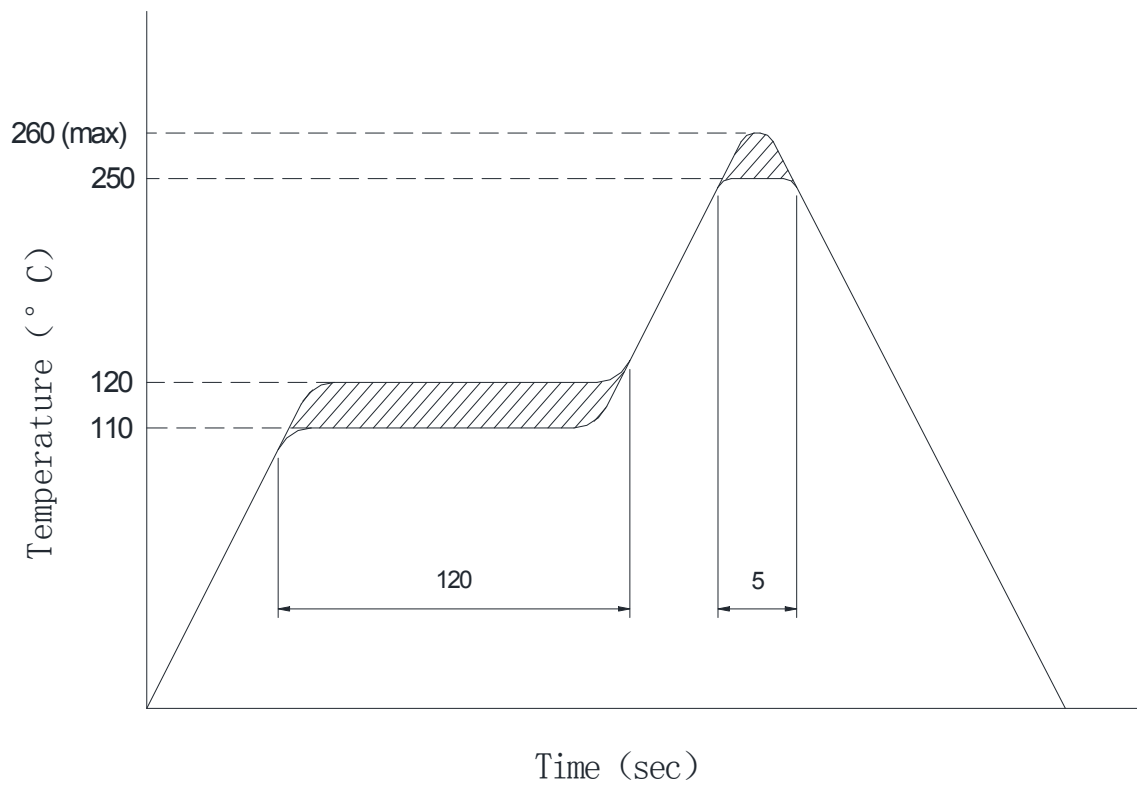

NOTES

After soldering the LEDs, the epoxy bulb should be protected from mechanical shock or vibration until the LEDs return to room temperature.

A rapid-rate process is not recommended for cooling the LEDs down from the peak temperature.