

EB-FCP-140-105-0976-03

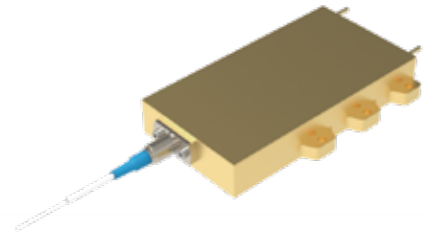

	单位 Unit	最小值 Min	典型值 Typ	最大值 Max
光学性能 /Optical				
中心波长 /Center Wavelength	nm		976	
中心波长偏差 /Wavelength Tolerance	nm		±3	
输出功率 /Output Power	W	140		
光谱宽度 (FWHM)/Spectral Width (FWHM)	nm		4.5	5
光纤数值孔径 /Numerical Aperture	-		0.16	
光纤芯径 /Fiber Core	μm		105	
光纤接头 /Fiber Connector	-		Pigtail	
光纤长度 /Fiber Length	m		2	
电学性能 /Optical				
光电转换效率 /Power Conversion Efficiency	%		54	
阈值电流 /Threshold Current	A		0.6	
工作电流 /Operating Current	A		14	
工作电压 /Operating Voltage	V		20	
热学性能 /Thermal				
工作温度 /Operating Temperature	°C		25	
存储温度 /Storage Temperature	°C		-35~75	
波长温度系数 /Wavelength Temperature Coefficient	nm / °C		0.33	
其他 /Others				
防反射波长范围 /Anti Reflection Wavelength Range	nm		1030-1200	
防反射效率 /Reflection Efficiency	dB		30	
焊接温度 /Soldering Temperature	°C		260(10 sec)	

备注 /Remarks

- 规格型号命名规则: EB (长光华芯缩写) – FCP (光纤耦合模块缩写) – 140 (输出功率) – 105 (光纤芯径) – 0976 (中心波长) – 03 (中心波长偏差)
- 以上数据是 25°C 温度下测试
- 避免在结露环境下存储和使用, 超过规定温度工作会影响寿命
- 超过正常功率范围使用会缩短使用寿命

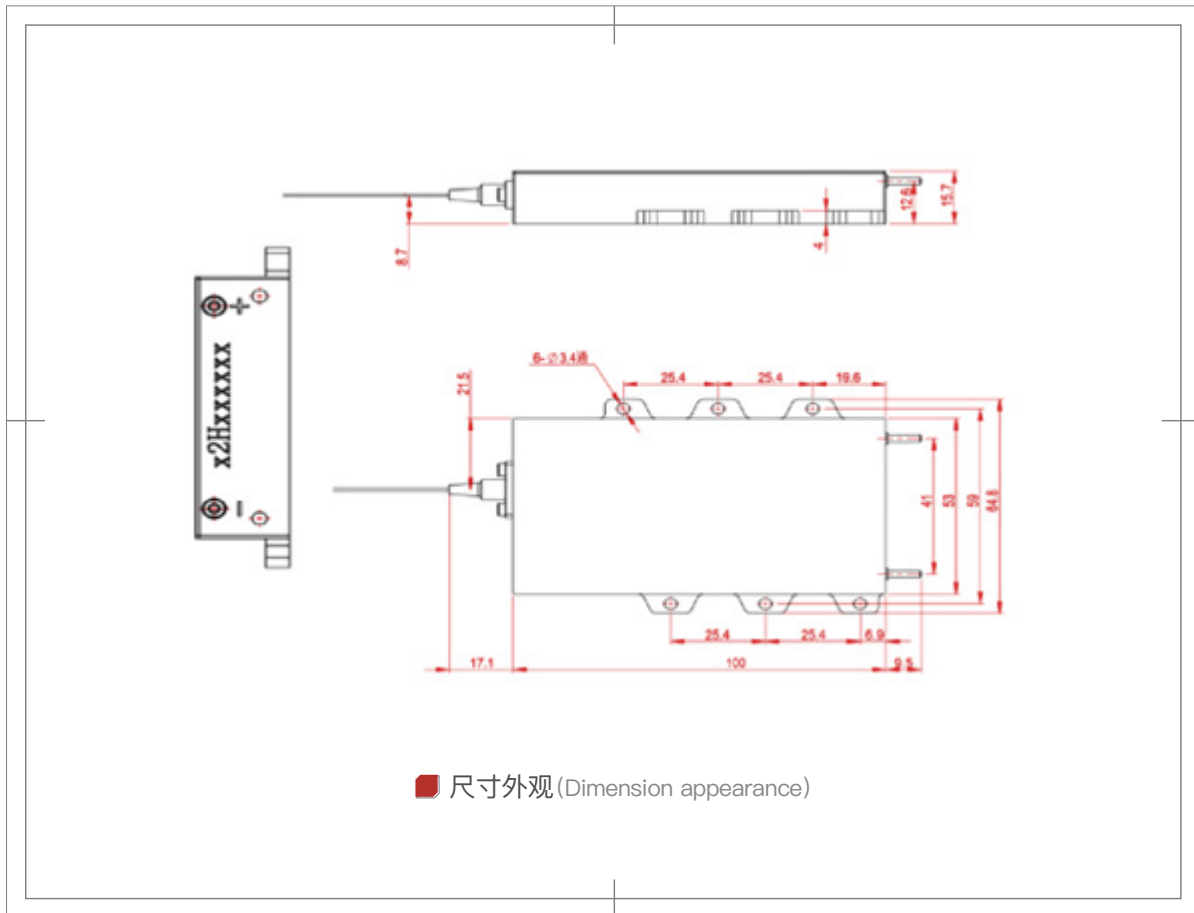

应用领域 / Application Area



中高功率工业光纤激光器泵浦
Medium / High power industrial fiber laser pumping

产品特点 / Product Features



高功率
High Power



高可靠性, 长寿命
High reliability, Long lifetime



小数值孔径
Small Numerical Aperture



光谱宽度小
Narrow Spectral Width



苏州长光华芯光电技术股份有限公司 SUZHOU EVERBRIGHT PHOTONICS CO., LTD
江苏省苏州市高新区科技城漓江路56号 No.56, Lijiang Road, SND, Suzhou, China
www.everbrightphotonics.com Sales@everbrightphotonics.com +86-512-66896988

声明: 长光华芯为客户提供卓越的产品和优质的服务。我们可能更改规格和产品描述, 届时将不另行通知。如需详细信息, 请联系长光华芯销售代表。
Notice: Everbright keep improving its products to provide our customers with outstanding quality and reliability. We may change the specification and product description without notice at any time. For complete details, please contact Everbright sales representative.

