

PRODUCT TYPE: HC-49US

FEATURES

- JYEG Part Number:JYS1,JYS2
- AT、BT available
- TAPES & Reel,insulator tab, 3rd lead
- Custom lead length options
- Tight tolerance/stability

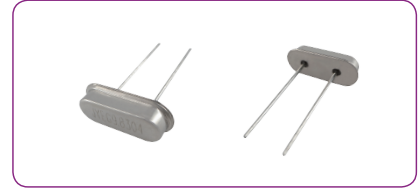

TYPICAL SPECIFICATIONS

ITEM / TYPE	HC-49US(JYS1,JYS2)		
Frequency Range	3.4875~41MHz	24.576~75MHz	24~44MHz
Mode of Vibration	AT Fundamental	AT 3rd Overtone	BT Fundamental
Resonance Resistance(Ω)	20~150	60~120	30~40
Frequency Tolerance at 25°C	$\pm 5\text{ppm} \sim \pm 50\text{ppm}$		
Shunt Capacitance	7pF Max.		
Frequency Stability Over Temperature Range	$\pm 5\text{ppm} \sim \pm 50\text{ppm}$, or specify	$\pm 50\text{ppm}/0^\circ\text{C} \sim +50^\circ\text{C}$	
		$\pm 100\text{ppm}/-10^\circ\text{C} \sim +60^\circ\text{C}$	
		$\pm 125\text{ppm}/-20^\circ\text{C} \sim +70^\circ\text{C}$	
Load Capacitance	3~50pF or Series		
Insulation Resistance	>500M Ω /DC100V ± 15 V		
Drive Level	10nW~1mW		
Aging	$\pm 3\text{ppm} \sim \pm 5\text{ppm}/\text{year}$		
Storage Temperature Range	-55~125°C		

HC-49US (JYS1,JYS2)

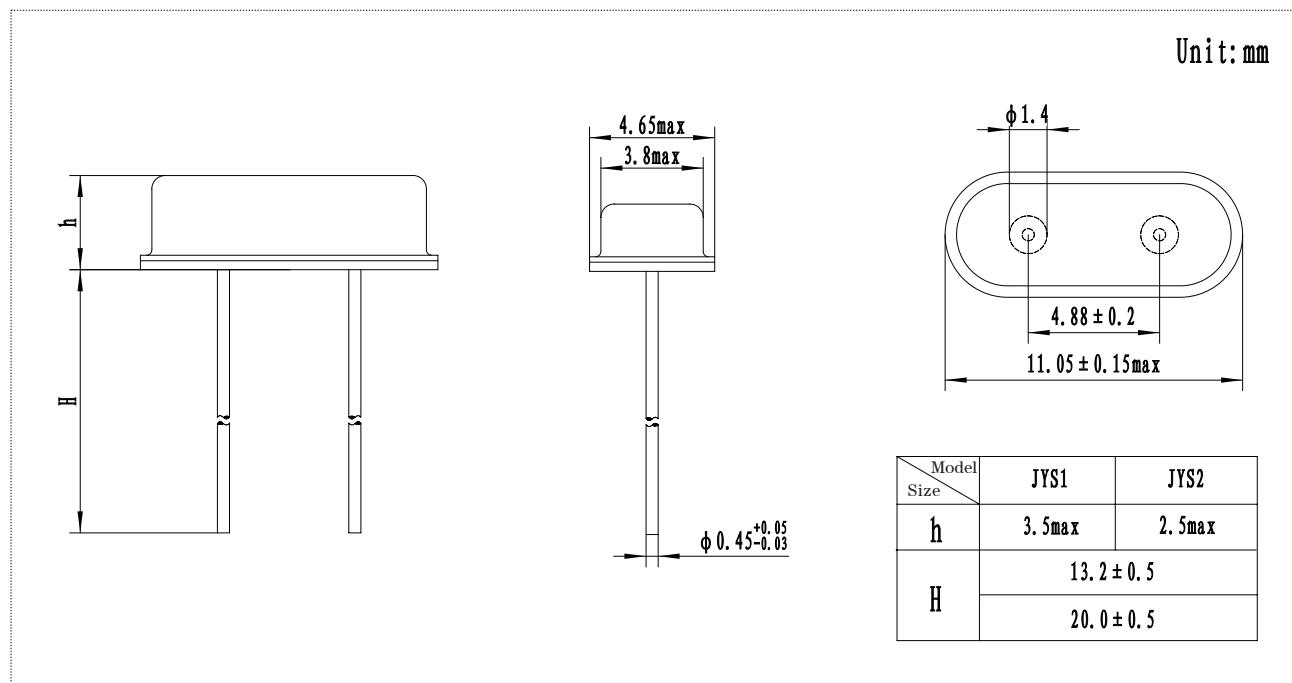

PRODUCT TYPE: HC-49US

FEATURES

- JYEG Part Number:JYS1-3
- Custom lead length options
- AT、 BT available
- Tight tolerance/stability
- TAPE & Reel,insulator tab, 3rd lead

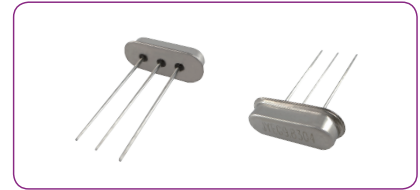

TYPICAL SPECIFICATIONS

ITEM / TYPE	HC-49US(JYS1-3)		
Frequency Range	3.4875~41MHz	24.576~75MHz	24~44MHz
Mode of Vibration	AT Fundamental	AT 3rd Overtone	BT Fundamental
Resonance Resistance(Ω)	20~150	60~120	30~40
Frequency Tolerance at 25°C	$\pm 5\text{ppm} \sim \pm 50\text{ppm}$		
Shunt Capacitance	7pF Max.		
Frequency Stability Over Temperature Range	$\pm 5\text{ppm} \sim \pm 50\text{ppm}$, or specify	$\pm 50\text{ppm}/0^\circ\text{C} \sim +50^\circ\text{C}$	
		$\pm 100\text{ppm}/-10^\circ\text{C} \sim +60^\circ\text{C}$	
		$\pm 125\text{ppm}/-20^\circ\text{C} \sim +70^\circ\text{C}$	
Load Capacitance	3~50pF or Series		
Insulation Resistance	$>500\text{M}\Omega/\text{DC}100\text{V} \pm 15\text{V}$		
Drive Level	10nW~1mW		
Aging	$\pm 3\text{ppm} \sim \pm 5\text{ppm}/\text{year}$		
Storage Temperature Range	$-55 \sim 125^\circ\text{C}$		

HC-49US (JYS1-3)

