



Durco T4E - PFA Lined Plug Valves ANSI 150 • DIN PN16 • ANSI 300

High-Performance Lined Chemical Service Valves



Experience In Motion

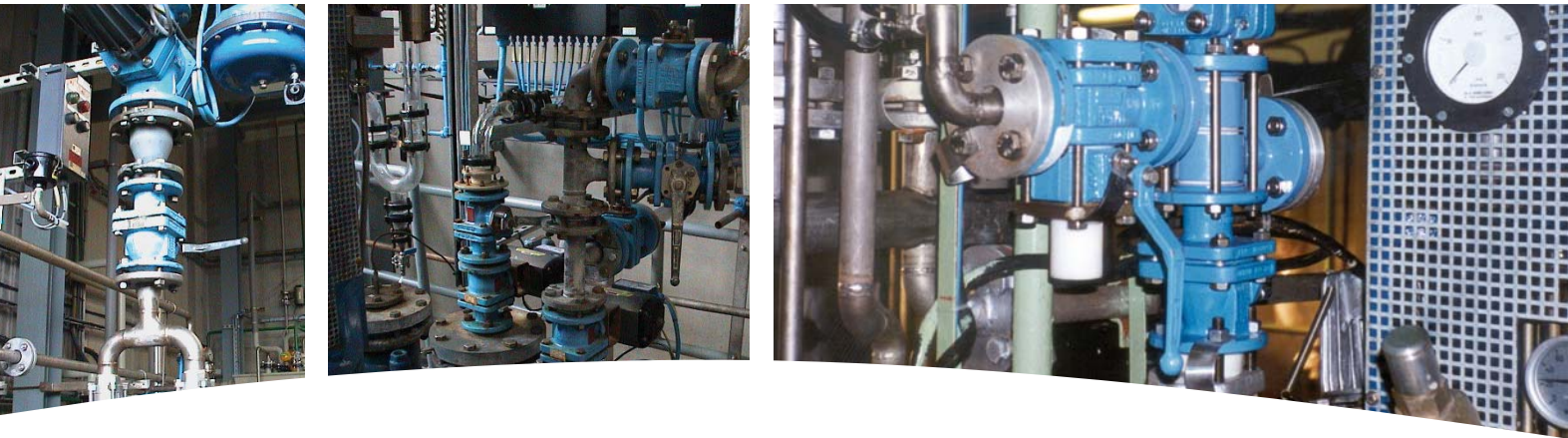

T4E – PFA Lined Plug Valve

The T4E series is designed and developed with the latest technology and therefore very suitable for the chemical process industries. The T4E valves provide maximum corrosion resistance and the elimination of product contamination at reasonable cost.

Standard Lockable Wrench Device

Offers you the possibilities to lock in open or closed position.

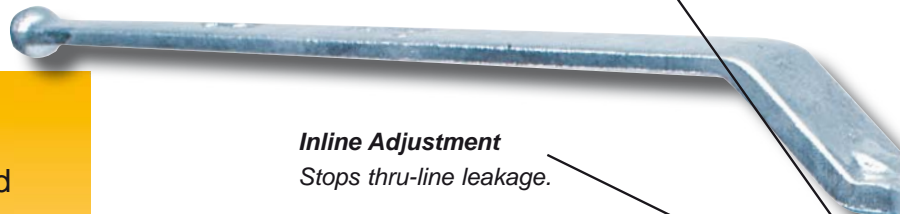

Inline Adjustment

Stops thru-line leakage.

ISO 5211 Mounting Pad

Universal flange for easy actuation mounting

Grounding Spring

To avoid build-up of static electricity.

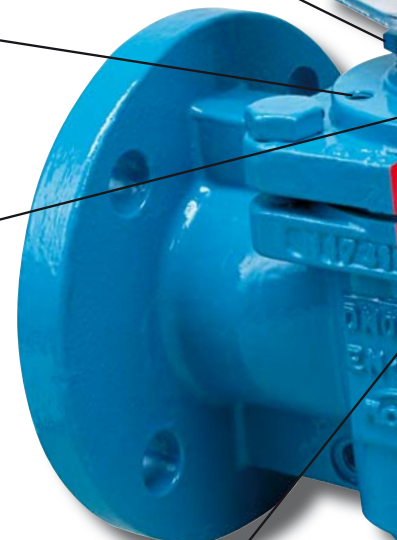

Available in Broad Size Range and Extended Pressure Class

- T4E1 ANSI Class 150 is available in sizes ½" through 12"
- T4E2 DIN Class PN16 is available in sizes DN15 through DN300
- T4E3 ANSI Class 300 is available in sizes ½" through 10"

Available with pneumatic or electric actuators for on-off or modulating control applications. Contact Flowserve Ahaus for availability V-port control plugs.

All T4E series are rated to 30 inches Hg vacuum, at ambient temperature.

T4E Series Offers an Extended Pressure Class:

- T4E1 ANSI Class 150 is rated 17.2 bar at 204°C (17.24 bar at 80°C)
- T4E2 DIN Class PN16 is rated 16 bar at 204°C (17.24 bar at 80°C)
- T4E3 ANSI Class 300 is rated 22 bar at 204°C (51.03 bar at 80°C)

Solid Encapsulated PFA Molded Plug

All plug inserts have anchor holes to ensure a strong adhesion of the plug PFA liner material even under extreme cycling conditions.



Double D Plug Stem

Plug stem end has a „Double D“ design. Accepts most standard actuation equipment.

Dynamic, Self-adjusting, Self-Energizing PFA Reverse Lip Diaphragm
(Optional stainless steel diaphragm support)

Anti-Rotating Lugs

Help to eliminate stress on fasteners during actuation.

Well Dimensioned Ports

Offer good Kv/Cv values.
Reduce frictional losses & pressure drops.

High Quality PFA Liner

Protects the body and forms the flange gasket. The PFA liner is resistant against a wide variation of chemical products

Cast Slots in Plug Area to Lock Liner

Offers a strong and reliable fit of the body liner even under extreme service conditions and cycling actions.

T-Slots in Critical Areas to Lock Liner Against Body Wall

Advantage will be a tight and perfect fit of the liner and an additional support during vacuum service.

Benefits that give you the extra security which you will appreciate when using the Flowserve T4E1, T4E2 and T4E3.

A perfectly fixed PFA body liner is well anchored to the body by mean of machined and cast T-slots. The solid encapsulated/ anchored PFA plug liner material ensures a strong adhesion.

Due to the selected mode to lock the liner to the valve body and plug the T4E valve series is very suitable for extreme service conditions including vacuum applications at elevated temperatures. The PFA body liner covers all wetted surfaces in the body and the plug extends are sufficiently covered as well.

Due to it's large sealing surface a drop-tight shut-off is assured.

In addition to the large seating area the valve is fully bi-directional and the seal is totally independent of line pressure.

A secondary dynamic self-adjusting, self-energized PFA reverse lip diaphragm prevents stem leakage.

Should line pressure force liquid to the stem seal area, the self-energizing PFA reverse lip diaphragm will be pushed against the stem surface and avoid external leakage.

You never replace valve seats; you only reseal the plug with a quick and easy in-line adjustment.

An open-end wrench and a few seconds are the extent of your maintenance requirements. There are:

- No seats to replace
- No lengthy production disruption
- No piping disconnection
- No complicated, time-consuming maintenance procedures
- No hazards to personnel

Technical Data

T4E1 (DN½"-DN6"), T4E2 (DN15-DN150)

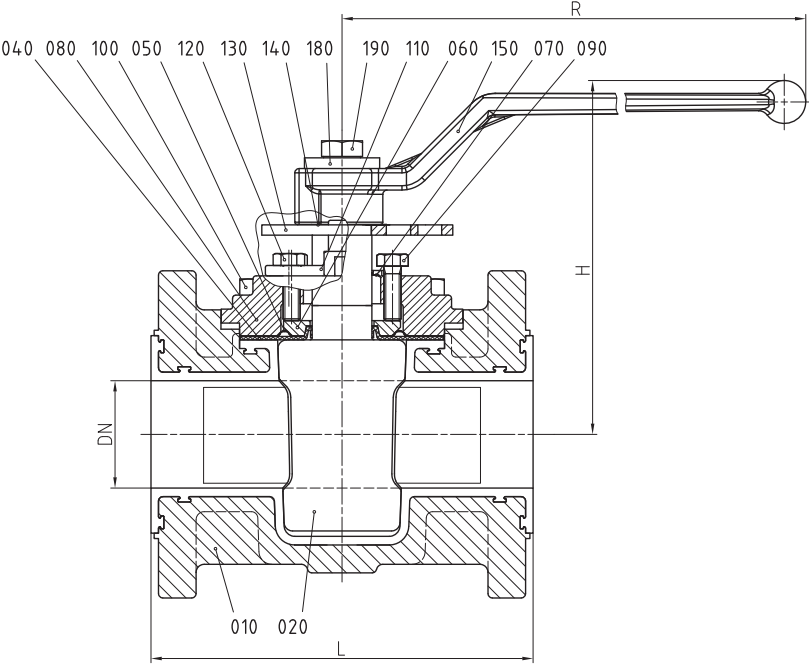

T4E1

Face-to-Face Dimensions:
ANSI B16.10 (short pattern)
Flange Connections:
ANSI B 16.5 (150lbs)

T4E2

Face-to-Face Dimensions:
DIN EN 558-1 (Basic series 1)
Flange Connections:
DIN 2501 (PN16)

T4E1 DN½" to DN6"

DN/ANSI	L	H	R	weight	
½"	108	139	260	kg	3,7
¾"	117,5	139	260	kg	4,1
1"	127	139	260	kg	4,9
1½"	165	145	260	kg	7,4
2"	178	165	410	kg	11,3
3"	203	179	410	kg	17,5
4"	229	222	674	kg	31,1
6"	267	-	-	kg	43,2

See page 5 for larger sizes

material specification

No.	Designation	Material
010	body	ductile cast iron - EN-JS1049/ASTM A395, PFA lined
020	plug	ductile cast iron - EN-JS1049/ASTM A395, PFA lined
040	diaphragm	PFA
050*	metal diaphragm	stainless steel - 302
060	thrust gland	machining steel - 1.0718
070	grounding spring	stainless steel - 302
080	top cap	ductile cast iron - EN-JS1049/ASTM A395
090	adjuster bolt	ASTM A193 grade B7
100	top cap bolt	ASTM A193 grade B7
110	stop	stainless steel ASTM A351/A744 grade CF-8M (316 SS)
120	stop fastener	stainless steel - 1.4301
130	stop collar	carbon steel, protective plated
140	stop collar retainer	stainless steel - 302
150	wrench	ductile cast iron - EN-JS1082/ASTM A536
180	washer	stainless steel - 1.4301
190	hexagon bolt	stainless steel - 1.4301

* optional

T4E2 DN15 to DN150

DN/DIN	L	H	R	weight	
015	130	139	260	kg	4,2
020	150	139	260	kg	4,9
025	160	139	260	kg	5,8
040	200	145	260	kg	9,1
050	230	165	410	kg	13,2
080	310	179	410	kg	20,8
100	350	222	674	kg	34,7
150*	267	-	-	kg	43,2

* Face-to-Face dimensions acc. ANSI B 16.10 (short pattern)
See page 5 for larger sizes

material specification

No.	Designation	Material
010	body	ductile cast iron - EN-JS1049/ASTM A395, PFA lined
020	plug	ductile cast iron - EN-JS1049/ASTM A395, PFA lined
040	diaphragm	PFA
050*	metal diaphragm	stainless steel - 302
060	thrust gland	machining steel - 1.0718
070	grounding spring	stainless steel - 302
080	top cap	ductile cast iron - EN-JS1049/ASTM A395
090	adjuster bolt	stainless steel - 1.4301
100	top cap bolt	stainless steel - 1.4301
110	stop	stainless steel ASTM A351/A744 grade CF-8M (316 SS)
120	stop fastener	stainless steel - 1.4301
130	stop collar	carbon steel, protective plated
140	stop collar retainer	stainless steel - 302
150	wrench	ductile cast iron - EN-JS1082/ASTM A536
180	washer	stainless steel - 1.4301
190	hexagon bolt	stainless steel - 1.4301

* optional

Technical Data

T4E3 (DN½"-DN6")

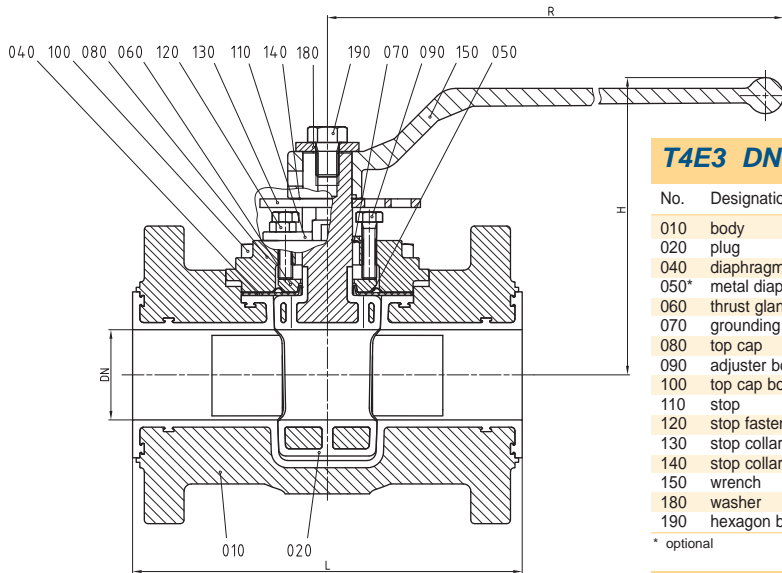

T4E3 DN½" to DN6" - material specification

No.	Designation	Material
010	body	carbon steel ASTM A216 grade WCB, PFA lined
020	plug	ductile cast iron - EN-JS1049/ASTM A395, PFA lined
040	diaphragm	PFA
050*	metal diaphragm	stainless steel - 302
060	thrust gland	machining steel - 1.0718
070	grounding spring	stainless steel - 302
080	top cap	duplex stainless steel ASTM A351 Gr CD4MCu
090	adjuster bolt	ASTM A193 grade B7
100	top cap bolt	ASTM A193 grade B7
110	stop	stainless steel ASTM A351/A744 grade CF-8M (316 SS)
120	stop fastener	stainless steel - 1.4301
130	stop collar	carbon steel, protective plated
140	stop collar retainer	stainless steel - 302
150	wrench	ductile cast iron - EN-JS1082/ASTM A536
180	washer	stainless steel - 1.4301
190	hexagon bolt	stainless steel - 1.4301

* optional

T4E3 DN½" to DN6"

DN/ANSI	L	H	R	weight
½"	139,5	139	260	kg 4,6
¾"	152,5	139	260	kg 5,6
1"	165	139	260	kg 6,5
1½"	190,5	145	260	kg 10,1
2"	216	165	410	kg 14,0
3"	282,5	179	410	kg 23,7
4"	305	222	674	kg 42,4
6"	403,5	-	-	kg 69,2

T4E3

Face-to-Face Dimensions:
ANSI B 16.10

Flange Connections:
ANSI B 16.5 (300lbs)

T4E1 (DN8"-12"), T4E2 (DN200-300), T4E3 (DN8", 10")

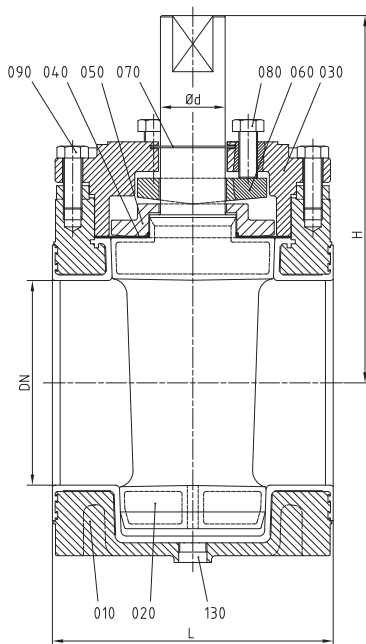

T4E1

Face-to-Face Dimensions:

ANSI B16.10 (short pattern)

Flange Connections:

ANSI B 16.5 (150lbs)

T4E2

Face-to-Face Dimensions:

ANSI B16.10 (short pattern)

Flange Connections:

DIN 2501 (PN10)

T4E3

Face-to-Face Dimensions:

ANSI B 16.10

Flange Connections:

ANSI B 16.5 (300lbs)

T4E1 DN8" to DN12", T4E2 DN200 to DN300 - material specification

No.	Designation	Material
010	body*	ductile cast iron - EN-JS1049/ASTM A395*, PFA lined
020	plug	ductile cast iron - EN-JS1049/ASTM A395, PFA lined
030	top cap	ductile cast iron - EN-JS1049/ASTM A395
040	diaphragm	PFA
050	thrust gland	duplex stainless steel ASTM A351 Gr CD4MCu
060	adjuster	duplex stainless steel ASTM A351 Gr CD4MCu
070	grounding spring	stainless steel - 302
080	adjuster bolt	stainless steel - 1.4301
090	hexagon bolt	stainless steel - 1.4301
130	locking screw	stainless steel - 1.4401

* other material of request

T4E3 DN8", DN10" - material specification

No.	Designation	Material
010	body	carbon steel ASTM A216 grade WCB / PFA lined
020	plug	ductile cast iron - EN-JS1049/ASTM A395, PFA lined
030	top cap	ductile cast iron - EN-JS1049/ASTM A395
040	diaphragm	PFA
050	thrust gland	duplex stainless steel ASTM A351 Gr CD4MCu
060	adjuster	duplex stainless steel ASTM A351 Gr CD4MCu
070	grounding spring	stainless steel - 302
080	adjuster bolt	stainless steel - 1.4301
090	hexagon bolt	stainless steel - 1.4301
130	locking screw	stainless steel - 1.4401

T4E1 DN8" to DN12" (150 lbs), T4E2 DN200 to DN300 (PN10)

DN	L	H	Ød	weight
8"	200	292,1	362	63,4 kg 157,0
10"	250	330,2	431,8	76,2 kg 190,0
12"	300	355,6	454	76,2 kg 220,0

T4E3 DN8", DN10" (300 lbs)

DN	L	H	Ød	weight
8"	419	362	63,4	kg 185,0
10"	457	432	76,2	kg 216,0



FCD DVATB0001-01 Printed in Germany. (Replaces FCD DVATB0001-00)

To find your local Flowserve representative:

For more information about Flowserve Corporation,
visit www.flowserve.com



Flowserve Ahaus GmbH
von-Braun-Straße 19a
D-48683 Ahaus, Germany
Telephone: +49 (0) 2561 686 100
Telefax: +49 (0) 2561 686 200

Due to continuous development of our product range, we reserve the right to alter the dimensions and information contained in this leaflet as required. Information given in this leaflet is made in good faith and based upon specific testing but does not, however, constitute a guarantee