Warranty

GAINKAITA

Gainkaita warrants that Products are free from defects in material and workmanship, and when properly used, will perform in accordance with Gainkaita's applicable published specification. If within one (1) year after original shipment it is found not to meet this standard, it will be repaired, or at the option of Gainkaita, replaced at no charge when returned to a Gainkaita service facility.

Changes in the Product not approved by Gainkaita shall void this warranty.

Gainkaita shall not be liable for any indirect, special or consequential damages, even if notice has been given of the possibility of such damages.

This warranty is in lieu of all other warranties, expressed or implied, including, but not limited to any implied warranty or merchantability or fitness for a particular purpose.

SERVICE POLICY

Gainkaita policy is to maintain product repair capability for a period of five (5) years after original shipment and to make this capability available at the then prevailing schedule of charges.

1.1 General

The 1062 LCZ meter is microprocessor-controlled automatic LCZ testers that provide high accuracy, convenience, speed, and reliability at low cost. Both test frequency and voltage are selectable. With the IEEE-488 INTERFACE option, each meter can respond to remote control. And the HANDLER INTERFACE option, enables the instrument to control and respond to parts handling equipment.

The versatile, adaptable test fixture, single-function keys, and informative display panel make the 1062 convenient to use. Measurement results are clearly shown with decimal points and units, which are automatically presented to assure correctness. Display resolutions are both up to 4 1/2 full digits for L/C/|Z|/Δ % on A DISPLAY and Q/D/R/θ on B DISPLAY (notice that R in SERIES circuit mode is also known as ESR). Preset measurement frequency or voltage (selectable) is displayed simultaneously in 3 digits with unit.

The basic accuracy is 0.1%. Calibration to account for any change of test-fixture parameters is semiautomatic; the operator needs to provide only open-circuit and short-circuit conditions in the procedure.

Range selection is automatic or manual selectable. And equivalent series or parallel circuit mode is selectable in a toggle mode.

A **COMPARATOR** in form of two 5-digit and two 3-digit thumb switches is provided to use the limit-comparison capability of the instrument to categorize the parts.

All the measurement status, zeroing data, and set up limits (include decimal points and units) are retained in non-volatile memory even power off. It is convenient for daily operation.

The external test fixture or cables are always necessary for the instruments; and true 4-terminal connections are made automatically.

1.3 ACCESSORY CHECK BEFORE USE

Upon receipt of this instrument, please check the following items:

- (1) Any damage or scratch in the outlook the product.
- (2) Any missing accessory listed in Table 1-1 and 1-2.

If you find any damage or missing accessory, please notice our company, branches, or agents for prompt service.

Table 1-1 Standard Accessory

Item	Part No.	Quantity	Comment
Power cord	27-82018-181	1	Power cord
3P - 2P Adapter	22-88110-122	1	for change power plug
Test cable	27-A2903-77A	1	77cm long for cilpper use
Power fuse slow 0.6A 32m/m	26-16000-209	1	AC 100V/120V use
Power fuse slow 0.3A 32m/m	26-13000-209	1	AC 220V/240V use
Operation manual	49-10613-001	1	

Table 1-2 Optional Accessory

Item	Part No.	Quantity	Comment
Test fixture (1)	61-00BOX-001	1	No extension cable.
Test fixture (2)	61-01000-002	1	1 m extension cable.
Test fixture (3)	61-00BOX-002	1	Test fixture
SMT Test Cable	61-01000-012	1	SMT Test Cable
BNC Test Cable	61-01000-013	1	BNC Test Cable
LCR Test Cable	61-01000-015	1	LCR Test Cable
Handler Test Cable	61-01000-016	1	Handler Test Cable
GPIB Interface	55-25007-000	1	For linking with IEEE-488 interface.
Handler Interface	55-25013-000	1	Handler interface.

PS: To get the missing accessory, just name its Part No. to us.

2.1 Measurement Parameters

There are seven measurement parameter pairs in the 1062 LCZ meter; L/Q, L/D, L/R, C/Q, C/D, C/R and $|Z|/\theta$. In COMPARATOR-ENABLE mode, L/C/ $|Z|$ can be displayed in deviation % ($\Delta\%$) of the standard value setting.

- Principal parameters (on A DISPLAY)

L : Self-inductance (unit = uH, mH, H)

C : Static-capacitance (unit = mF, uF, nF, pF)

$|Z|$: Value of impedance (unit = Ω , k Ω , M Ω)

$\Delta\%$: Deviation percentage of L/C/ $|Z|$ (unit=%)

- Secondary parameters (on B DISPLAY)

Q : Quality factor

D : Dissipation factor

R : Resistance (unit = m Ω , Ω , k Ω)

θ : Phase angle (unit = $^\circ$; degree)

Note : R in SERIES equivalent circuit mode is known as ESR.

- Measurement ranges

L : .0000uH ~ 1999.9H

C : .0000pF ~ 199.99mF

$|Z|$: .0000 Ω ~ 199.99M Ω

$\Delta\%$: -100.00% ~ 100.00% ("UUUU" display for over 100%)

Q : .0000 ~ 19999

D : .0000 ~ 19999

R : .0000m Ω ~ 19999k Ω

θ : -180.00 $^\circ$ ~ 179.99 $^\circ$

Note : If any of these quantities (but not $|Z|$) is negative, the "-" sign will be indicated.

- Displays

4 1/2-digit display for both A and B display.

3-digit display for measurement frequency and signal level.

And the resolutions are:

Table 2-1 Measurement resolution list

Parameter	Resolution	
	Minimum	Maximum
L	.0001 μ H	0.1H
C	.0001pF	0.01 mF
Z	.0001 Ω	0.01M Ω
D,Q	.0001	1
R	.0001 m Ω	1K Ω
θ	.0001 $^{\circ}$	0.01 $^{\circ}$
Δ %	0.01%	

- Equivalent circuit

Either the equivalent SERIES or equivalent PARALLEL circuit representation of L, C or R may be selected by keyboard control.

2.2 Accuracy

- Within 1 year after factory calibration.
- Temperature : 23 $^{\circ}$ C \pm 5 $^{\circ}$ C
- Relative humidity : 80% maximum
- Warm up : 30 minutes minimum.
- Measurement rate : Slow .
- Zero calibrated under conditions above.

1). |Z| - θ Accuracy

The basic accuracy is listed in Table 2-2.

- For Fast rate, on all ranges, the accuracy must be doubled.
- At frequency below 400Hz and signal level less than 260mV will cause additional unquantifiable errors dependent on measurement fixture layout.

- For $|Z| < 0.2\Omega$ (f in kHz, Z_x in Ω)
 - $f < 1K$: Accuracy = $\pm [0.1 + 0.005/(f \times Z_x)] \%$
 - $f \geq 1K$: Accuracy = $\pm [0.1 + (0.005 \times f)/Z_x] \%$
 - Accuracy of $\theta = \text{Accuracy of } |Z| (\%) \times 0.6^\circ$

Table 2-2 $|Z| - \theta$ Accuracy

$ Z \Omega$		Measurement Frequency (Hz)					
		40 100	120 400	1K	2K 10K	15K 60K	100 200K
200M 100M	×	7.9%	7.7%	7.4%	67%	/	/
	0	4.0°	4.0°	4.0°	40°		
100M 20M	×	4.2%	4.1%	3.7%	33.7%	/	/
	0	2.2°	2.1°	1.8°	20°		
20M 10M	×	0.84%	0.82%	0.77%	6.7%	64%	/
	0	0.45°	0.45°	0.40°	3.5°	35°	
10M 5M	×	0.47%	0.41%	0.41%	3.4%	32.3%	/
	0	0.3°	0.25°	0.22°	2.0°	18°	
5M 2M	×	0.24%	0.23%	0.23%	1.8%	16.4%	/
	0	0.15°	0.13°	0.12°	1.0°	10.0°	
2M 1M	×	0.13%	0.13%	0.13%	0.72%	6.9%	92%
	0	0.1°	0.09°	0.06°	0.4°	4.0°	55°
1M 200K	×	0.1%	0.1%	0.1%	0.4%	3.7%	46%
	0	0.1°	0.08°	0.05°	0.3°	2.0°	30°
200K 50K	×	0.1%	0.1%	0.1%	0.12%	0.84%	9.6%
	0	0.06°	0.05°	0.03°	0.08°	0.5°	5.5°
50K 2	×	0.1%	0.1%	0.1%	0.1%	0.26%	2.8%
	0	0.03°	0.03°	0.03°	0.05°	0.15°	1.5°
2 1	×	0.1%	0.1%	0.1%	0.1%	0.2%	1%
	0	0.05°	0.03°	0.03°	0.03°	0.12°	1.0°
1 0.5	×	0.2%	0.11%	0.1%	0.1%	0.56%	2.3%
	0	0.12°	0.06°	0.05°	0.08°	0.30°	1.5°
0.5 0.2	×	0.34%	0.2%	0.11%	0.11%	1.25%	4.9%
	0	0.20°	0.15°	0.06°	1.0°	0.8°	3.0°

2). L. C. Accuracy

For $Q \geq 10$ ($D \leq 0.1$), correspond to accuracy of $|Z|$, where

$$|Z_L| = |2\pi fL|$$

$$|Z_C| = |1/(2\pi fC)|$$

Refer to conversion chart between LC and $|Z|$ in Figure 2-1.

If $Q < 10$ ($D > 0.1$), multiply L accuracy by $(1 + 1/Q)$ and multiply C accuracy by $(1 + D)$.

3). D. Q Accuracy

For $D \leq 0.1$

$$\text{Accuracy of } D = \pm [(0.0175 \times \text{Accuracy of } \theta (\%))]$$

If $D > 0.1$, multiply D accuracy by $(1 + D^2)$

For all Q value

$$\text{Accuracy of } Q = \pm [(0.0175 \times \text{Accuracy of } \theta (\%) \times (1 + Q^2)]$$

4). R (ESR, EPR) Accuracy

For $Q \leq 0.1$

$$\text{Accuracy of } R = \text{Accuracy of } |Z|$$

If $Q > 0.1$, multiply accuracy by $(1 + Q)$

Figure 2-1 LC \leftrightarrow $|Z|$ conversion

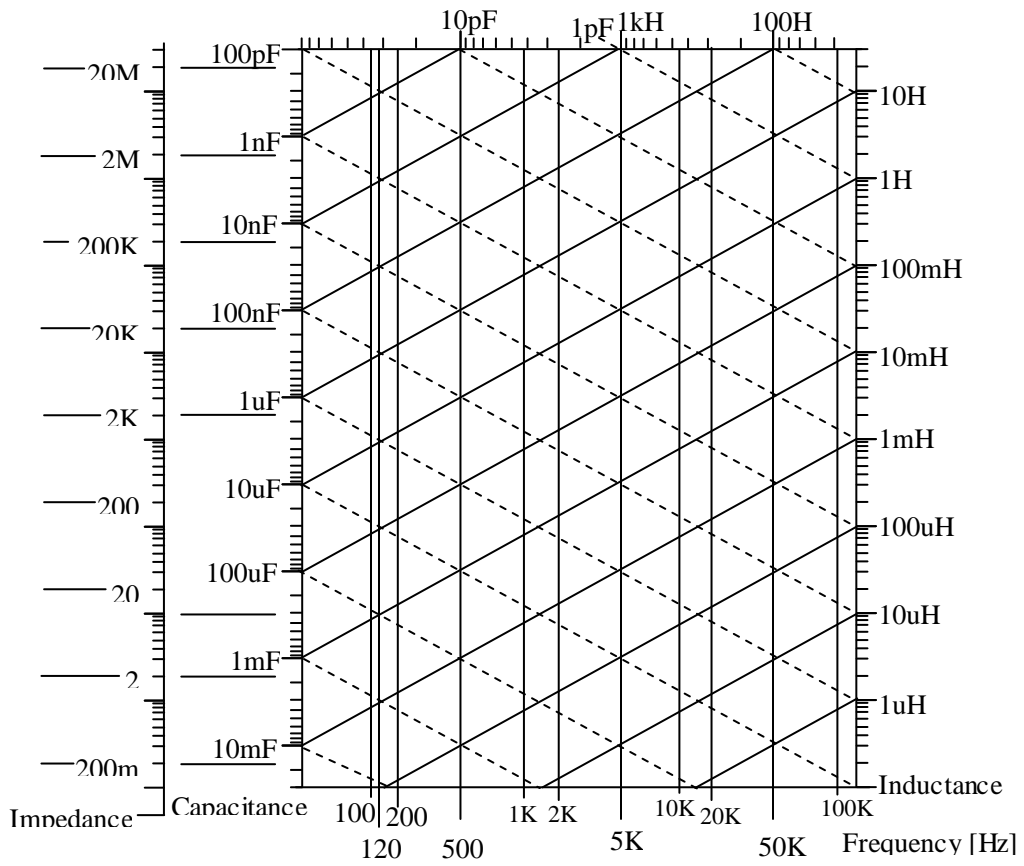

(a). LC \leftrightarrow $|Z|$ conversion chart

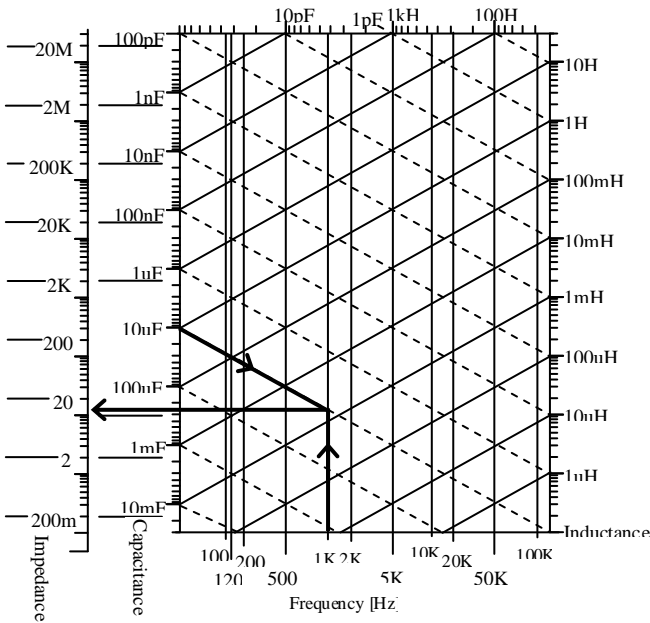

(b). C \rightarrow $|Z|$ conversion chart

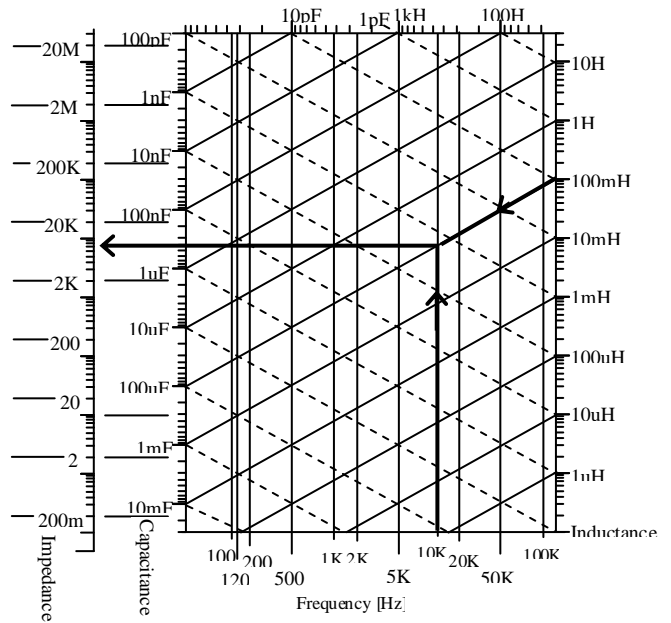

(c). L \rightarrow $|Z|$ conversion chart

The accuracy is:

$\pm(5\% + 2\text{mV})$, while frequency not exceeds 100kHz.

$\pm(8\% + 2\text{mV})$, while frequency exceeds 100kHz.

- DC Bias

An external bias of up to 35 VDC may be applied to capacitors under test using a panel push-push switch. The applied current should be limited to 1A.

2.5 ZEROING

Open : A simple OPEN operation removes the effects of stray capacitance and conductance of the external test fixture or cable.

Short : A similar SHORT zeroing operation removes the effects of series resistance and inductance.

2.6 MEASUREMENT TIME

Measurement rate is selected via the [RATE] key. The time required for a complete measurement is typically less than indicated in the following table.

Table 2-4 Measurement Time

Measurement Rate	Measurement Time					
	40Hz	100KHz	120KHz	1KHz	10KHz	100KHz
Slow	400mS	310mS	315mS	282mS	280mS	280S
Fast	250mS	120mS	117mS	70mS	69mS	68mS

Note : 1. If the measurement parameter is $|Z| - \theta$, add 5 ~ 10mS.

2. If IEEE-488 INTERFACE is optioned, add 3mS.

2.7 IEEE-488 INTERFACE (OPTIONAL)

When fitted with this option, the 1062 has a IEEE-488 interface according to the IEEE Std 488-1978 (including 1980 Supplement). All front panel functions are programmable from the bus. All L/C/Z, Q/D/R/ θ data are available as output to the bus. Output format is ASCII. The interface capabilities are:

SH1 -- source handshake (talker)
AH1 -- acceptor handshake (listener)
T5 -- talker (full capability, serial poll)
L4 -- listener (but no listen-only)
SR1 -- request by device for service from controller
RL1 -- complete capability (LLO, LOCAL)
PP0 -- no parallel poll
DC -- device clear
DT1 -- device trigger (typically starts measurement)
C0 -- no controller functions

2.8 HANDLER INTERFACE (OPTIONAL)

Outputs : Active low, open collector drivers rated at 30V max. Each will sink 16mA at 0.4V. External power and pull-up resistors required.

- Judgment outputs –A-GO, A-NG, A-HI, A-LO, B-GO, B-NG (6 lines)
- ACQ OVER – Indicates end of data acquisition .Component may be removed.
- EOM – Indicates end of measurement . Judgment output is valid.

Inputs : $0V \cong V1 \cong 0.4V$, $+2.5V \cong Vh \cong +5V$.

- Start – Initiates new measurement.

2.9 OTHERS

- Power : 95 to 125 V or 190 to 250 V AC, 48 to 62Hz. Voltage selected by rear panel switch; 50 watts maximum, 40 watts typical.
- Environment: Operating -- 0°C to 40°C, 10 to 90% relative humidity.
Storage -- -10°C to 50°C, 10 to 80% relative humidity.
- Dimensions : 405(W) × 130(H) × 365(D) mm.
- Weight : 4kg.

3.1 Ambient Environment

(1). Don't use the meter in a dusty or vibrating location. Don't expose it to direct sunlight, or corrosive gas. Be sure that the ambient temperature is 0~40℃ and that the relative humidity is below 85%.

(2). The meter is equipped in the back panel with a fan-out cooling fan to keep from internal temperature increase. Make sure of good ventilation. The meter should be located at over 10cm distance from any object or wall in the behind. Don't block the left and right ventilation holes to keep the meter in good precision.

(3). The meter has been carefully designed to reduce the noise from the AC power source. However, it should be used in a noise environment as low as possible. If the noise is inevitable, please install some power filter.

(4). The meter should be stored within the temperature range -25℃ ~ +70℃. In case it is not to be in use for a long time, please store it in the original or similar package, and keep it from direct sunlight and humidity, to ensure a good condition for later use.

Keep from following cases:

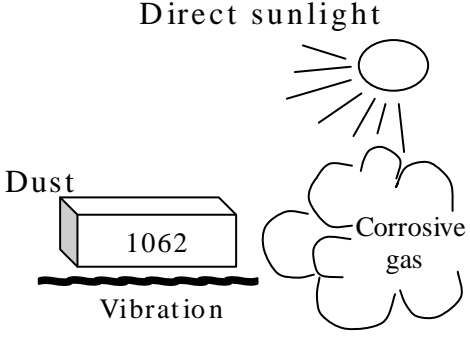

Direct sunlight

Dust

Corrosive gas

Vibration

1062

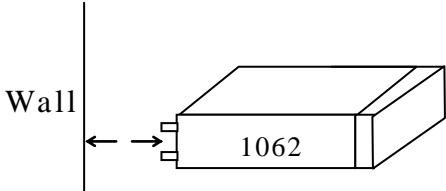

Wall

1062

Keep from objects in the Behind at over 10 cm.

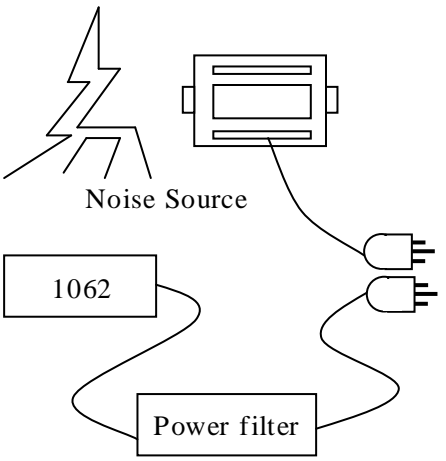

Noise Source

1062

Power filter

Please install a power filter in case of interference from high power noise.

3.2 POWER-LINE CONNECTION

The power transformer primary windings can be switched, by means of the line voltage switch on the rear panel, to accommodate ac line voltages in either of 2 ranges, as labeled, at a frequency of 50 or 60 Hz, nominal. Making sure that the power cord is disconnected, use a small screwdriver to set this switch to match the measured voltage of your power line.

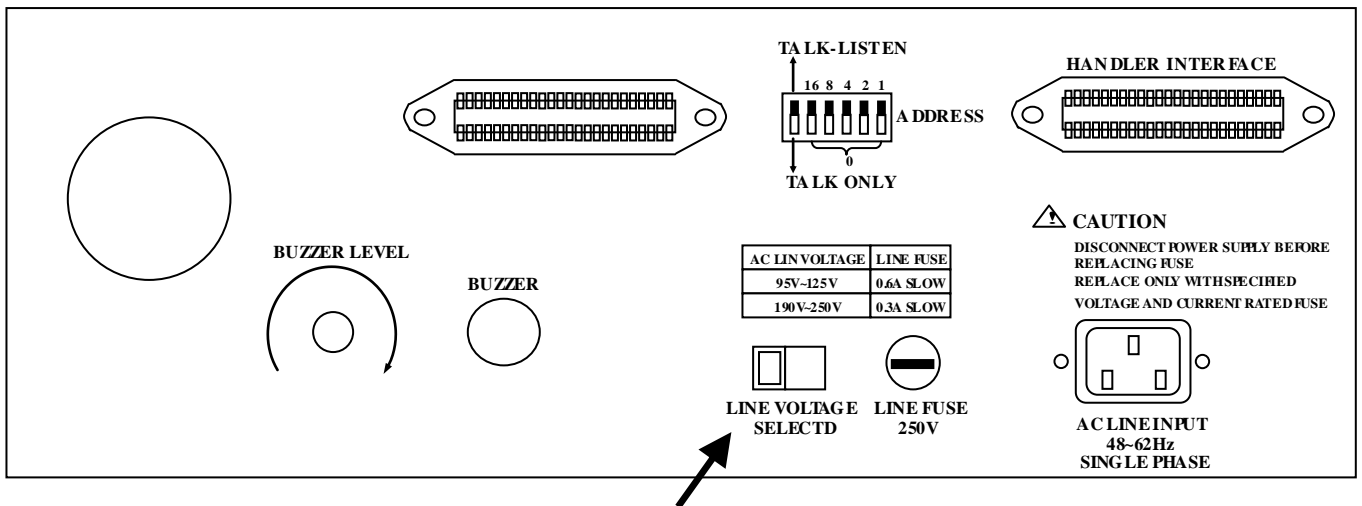

For safety and noise-prevent reasons, using a 3-wire power cable to connect between the power connector on the rear panel and the power line is required, or connect the GROUND terminal on the front panel to the earth for the same reasons.

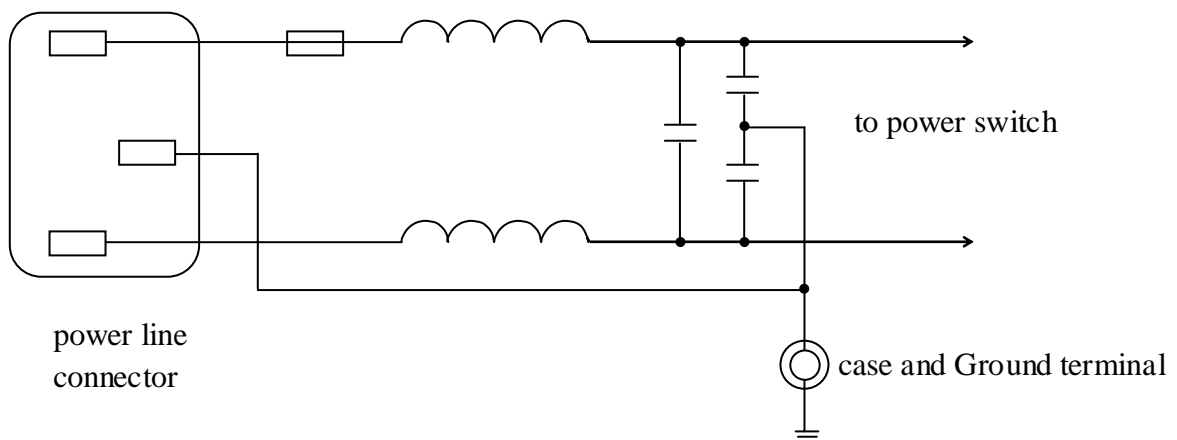

3.3 Line-Voltage Regulation

The accuracy of measurements accomplished with precision electronic test equipment operated from ac line sources can often be seriously degraded by fluctuations in primary input power. Line-voltage variations of $\pm 10\%$ are commonly encountered, even in laboratory environments. The use of line-voltage regulators between power lines and the test equipment is recommended as the only sure way to rule out the effects on measurement data of variations in line voltage.

3.4 UNKNOWN CONNECTION

An external test fixture is always required, because connect the 1062 LCZ meter to the DUT (Device Under Test) is provided via BNC connectors, which labeled Hcur, Hpot, Lpot, Lcur. It is important that the Lcur and Lpot leads connect to the same end of the DUT, Hcur and Hpot connect to the other end.

3.5 External Bias Voltage For The DUT

External bias can be provided by connecting a suitable current-limited, floating dc voltage source, as follows.

- Be sure that the voltage is never exceed 35V.
- A current limiting voltage supply is recommended; set the limit at 1A.
- Be sure that the bias supply is floating; do not connect either lead to ground.
- A sell-filtered supply is recommended. Bias-supply hum can affect some measurement, particularly if test frequency is the power frequency.
- Generally the external circuit must include switching for both application of bias after each DUT is in the test fixture and discharge before it is removed.
- Connect the external bias voltage supply and switching circuit, using the A10-001 cable (optional), via the front panel DC BIAS INPUT connectors. Observe polarity marking on the panel; connect the supply accordingly.

4.1 FRONT PANEL DESCRIPTION

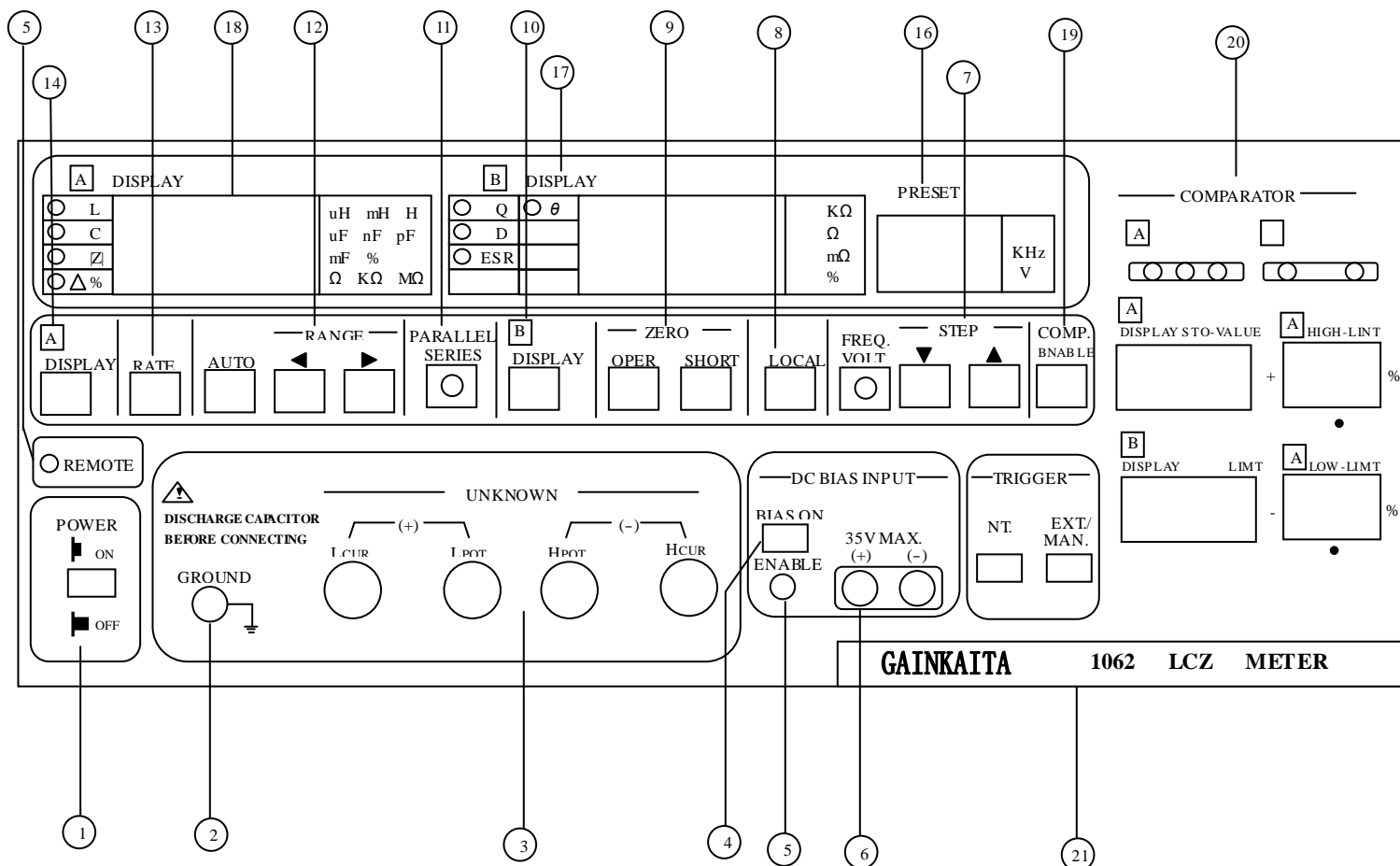

(1). POWER switch

Push button, push again to release. Switches the 1062 LCZ meter ON (button in) and OFF (button out). OFF position breaks both side of power circuit.

(2) GROUND terminal

This terminal is directly connected with case. Connecting it to the test fixture for shielding.

(3) UNKNOWN measurement connectors

Four BNC connectors. Connecting an external test fixture or cable for unknown measurement.

H_{cur} : Current drive terminal, high.

H_{pot} : Potential detector terminal, high.

L_{pot} : Potential detector terminal, low.

L_{cur} : Current drive terminal, low.

Notice that "high" terminals for (+) and "low" terminals for (-) polarity as marked on the front panel while polarized components is under test.

CAUTION

Discharge Capacitors Before Connecting

(4). BIAS ON indicator

LED indicator, indicates that external DC BIAS ENABLE is push-locked enables the bias input.

(5). ENABLE switch

Press switch, is accessed from the front panel with a bladed screwdriver. In the "out" position, bias input is disabled and in the "in" position, bias input is enabled.

(6). DC BIAS INPUT connector

Two dc jacks, labled (+) (-) 35V MAX. Receives cable A10-001 for external bias supply. Observe the voltage and current limits and polarity.

(7). [FREQ/VOLT], ▲ ▼ [] control keys

Measurement frequency and voltage adjustors, where

[FREQ/VOLT] : Selection of measurement FREQUency or VOLTage setting.

An on-key indicator is lit for VOLT.

[▲] : Step up trigger, keep pressed for replicating.

[▼] : Step down trigger, keep pressed for replicating.

(8). [LOCAL] key

When the instrument is in the IEEE-488 remote state (REMOTE indicator on), the [LOCAL] key will return the instrument to front panel operation. However, if local lockout (LLO) was asserted over the IEEE-488 bus, the [LOCAL] key will be inoperative.

(9). ZERO – [OPEN], [SHORT] keys

Open circuit and short circuit zeroing keys.

[OPEN] : An OPEN zeroing will remove the effects of stray capacitance and conductance of the external test fixture or cable.

[SHORT] : An SHORT zeroing operation removes the effects of series resistance and inductance.

(10). [B DISPLAY] key

Selection of secondary parameter Q, D, R or θ . One of Q, D, R and θ indicators on B DISPLAY is lit for the selection. There are both 3 parameters of Q, D and R can be selected in L and C measuring, but only θ is available in Z measuring.

(11). [PARALLEL/SERIES] key

Selection of equivalent circuit. An on-key indicator is lit for SERIES. Measured principal L, C and secondary R values depend on this selection.

(12). RANGE – [AUTO], [◀] [▶] keys

Selection of measurement range.

[AUTO] : Automatic ranging, an on-key indicator is lit when selected. Operating it for the indicator is off, this means the range is held. The on-key indicator will flash for error range selection.

[◀] : Lower impedance measurement range selection and hold the range. A range number will be shown on A DISPLAY about 1sec.

[▶] : Higher impedance measurement range selection and hold the range. A range number will be shown on A DISPLAY about 1sec.

(13). [RATE] key

Selection of measurement rate. There are fast, and slow 2 measurement rates selectable in sequence. The measurement time as described in paragraph 2.6 . Use slow rate for better accuracy. The parameter indicators in A DISPLAY will flash in the rate selected.

(14). [A DISPLAY] key

Selection of principal measurement parameter L, C, or |Z|; in sequence L-C-|Z|-L... as indicated on A DISPLAY. And also can select A DISPLAY in deviation % (Δ %) of L/C/|Z| if comparison is enabled.

(15). REMOTE indicator

LED indicator, indicates when remote control is established by external command. (Functions only if the IEEE-488 INTERFACE option is installed.)

(16). PRESET display

Display of preset measurement frequency or voltage. Includes a 3 numerals digital display and 2 unit indicators; "kHz" for frequency and "V" for voltage display selection.

(17). B DISPLAY display

Display of secondary measured value. Includes a 4 1/2 numerals digital display, 4 parameter LED indicators (Q, D, R, θ), and 4 unit indicators($^{\circ}$, k Ω , Ω , m Ω), and a % indicator (for low limit setting).

(18). A DISPLAY display

Display of principal measured value. Includes a 4 1/2 numerals digital display, 4 parameter LED indicators (L, C, |Z|, Δ %), and 11 unit indicators (uH, mH, H, mF, uF, nF, pF, Ω , K Ω , M Ω , %).

(19). [COMP.ENABLE] key

Enable the COMPARATOR function. The measured result will be compared with the set limits, and judged in HI, GO, LO, NG...etc. An on-key indicator is lit for ENABLED.

(20). COMPARATOR unit

Limit values setting and comparison results indicating. The limit values Setting includes standard value, high limit %, low limit % of A DISPLAY parameter, and limit of B DISPLAY parameter.

The comparison results includes High, Good, Low for A DISPLAY parameter and Good, No-Good for B DISPLAY parameter.

This unit is enabled by [COMP.ENABLE] key.

(21). TRIGGER – [INT], [EXT./MAN.] key.

Selection of trigger mode. INT, internal (continuously) trigger, repeating measurements; EXT. /MAN. , single measurement initiated by pressing [EXE. /MAN.] key manually or external input signal.

On-key indicators are lit for selection.

4.2 REAR PANEL DESCRIPTION

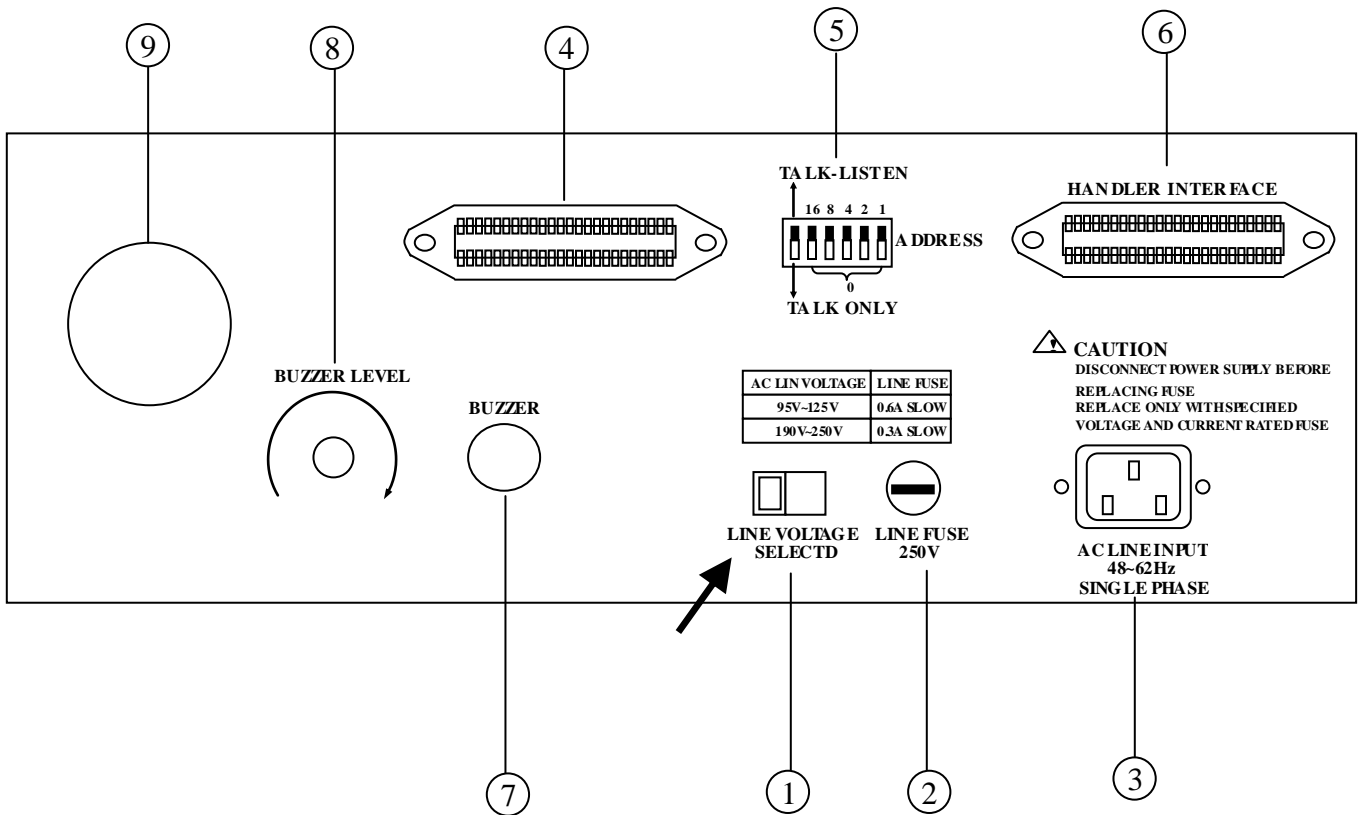

(1). AC LINE INPUT connector

Shrouded 3-wire plug, conforming to International Electrotechnical Commission 320. Use appropriate power cord, with Belden SPH-386 socket or equivalent. The A00-001 power cord (supplied) is rate for 125V.

(2). LINE FUSE

A 0.6A or 0.3A fuse is equipped to prevent the instrument from overtaking current from a 95~125V or 190~250V power line.

(3). LINE VOLTAGE SELECTED switch

Adapts power supply to line voltage ranges, as indicated. To operate use a small screw driver, not a sharp object.

- (4). IEEE-488 INTERFACE connector (interface option only)
Input/output connections according to IEEE Std 488-1978. Functions: complete remote control. Output of selected results, with or without controller. Receives IEEE-488 interface cable.
- (5). ADDRESS, TALK-ONLY/TALK-LISTEN switches
(IEEE-488 interface option only).
IEEE-488 interface address setting switches and
TALK-ONLY/TALK-LISTEN mode selecting switch.
- (6). HANDLER INTERFACE connector (interface option only)
Connections to component handler (outputs are GO NG etc. and status; input is a "start" signal). Receives Amphonol "Microribbon" plug P/N 57-30240 or equivalent.
- (7). BUZZER hole
Don't block this hole to ensure the BUZZER function normal as described in this manual.
- (8). BUZZER LEVEL adjuster
Clockwise to increase, and counterclockwise to decrease.
- (9). FAN
Fan-out cooling fan, to keep from internal temperature increase.

5.1 STARTUP**CAUTION**

Set the line voltage switch properly (rear panel)

Before connecting the power cord.

The regular startup procedure is:

(1). After the line voltage switch has been set to the position that corresponds to your power line voltage, then connect the power cord as explained below.

Temperature: If the instrument has been very cold, warm it up in a dry environment, allowing time for the interior to reach 0°C or above, before applying power. Otherwise, the instrument may be damaged by thermal shock.

Power Cord: Connect the power cord to the rear panel connector, and then to your power socket.

(2). If the IEEE-488 interface is installed, set TALK switch (rear panel) to TALK-ONLY (unless instructions are to be received through the IEEE-488 bus).

(3). Push BIAS ENABLE switch to off (out position).

(4) Press the POWER button "in", so that it stays in the depressed position. The buzzer beeps 2 seconds, then all display and indicators (not BIAS ON) are lit for 1 second, and then shows "CH-1062" briefly, indicating that the instrument is automatically executing a power-up routine.

(5) Wait until the measurement is running, and all measurement states are retained as last power-off.

If any abnormal condition occurs, notify the sales office please.

5.2 PRINCIPAL MEASUREMENT CONDITION

- Measurement Frequency Selection

There are 30 frequencies between 40 Hz and 200 KHz available in the instrument.

They are (in Hz):

40, 50, 60, 100, 120, 200, 400, 800, 1K, 2K, 5K, 10K, 15K, 15.7K, 16K, 20K, 22.2K, 25K, 30K, 40K, 50K, 60K, 66.6K, 75K, 80K, 100K, 120K, 150K, 160K, 200K.

Select the PRESET display in Frequency display by pressing [FREQ/VOLT] key. The actual frequency shown will be the last value selected, held in a non-volatile store. Using the [▲] and [▼] keys to increase or decrease the frequency to any of the discrete value listed above. Holding press either these keys will produce a continuous increase or decrease which, after a short while, becomes faster. The change ceases when the limit (upper or lower) is reached.

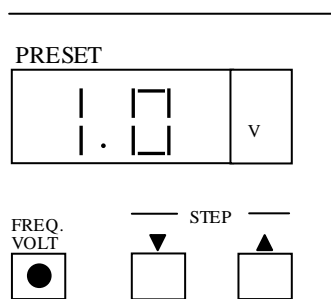

Measurement voltage selection

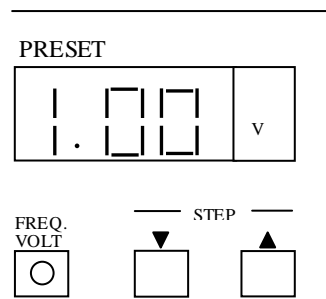

Measurement frequency selection

- Measurement Voltage Selection

The RMS measurement voltage is selectable from 20mV to 1.0V, steps 20mV. Select the PRESET display in Voltage display by pressing [FREQ/VOLT] key. The actual frequency shown will be the last value selected, held in a non-volatile store. And the procedure for changing the measurement voltage is similar to that for measurement frequency (above). The drive currents of the measurement signal in range 1 and 2 are 4mA~100mA correspond to 40mV~1.0V of the preset voltage.

5.3 CONNECTING THE TEST FIXTURE

There are a GROUND terminal and four BNC connectors on the front panel.
 GROUND: This terminal is directly connected with case. Connecting it to the test fixture for shielding.

HCUR (+): Current drive terminal, high.

HPOT (+): Potential detector terminal, high.

LPOT (-): Potential detector terminal, low.

LCUR (-): Current drive terminal, low.

Connecting them to an external test fixture or cables for unknown measurement. If cables is used, it is important that connect the same color (covered on the head of the cable, red preferly for + polarity) cables to HCUR and HPOT terminals, and connect the other cables (black

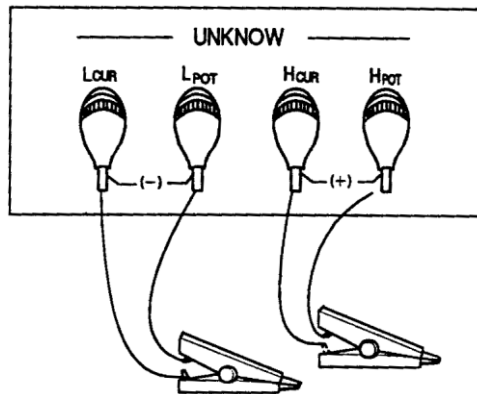

for - polarity) to LCUR and LPOT terminals.

Test Cables Connection

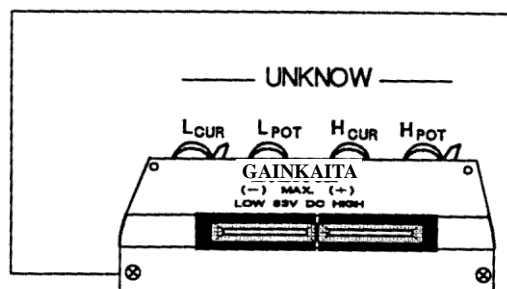

Test Fixture Connection

5.4 Zeroing

Before measurement, zero the instrument as follows. In this process, the instrument automatically measures stray parameters and retains the data in non-volatile memory, which it uses to correct measurements so that results represent parameters of the DUT alone, without test fixture capacitance.

- (1). Conditions: Slow measurement rate, 1V measurement voltage, autorange.
- (2). Open Circuit:
 - Connect the remote test fixture or at least the BNC cables and adaptors that will contact the DUT.

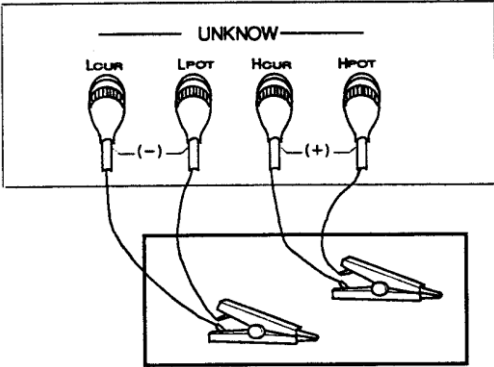

- Be sure that the test fixture is open circuited.
- Press [OPEN] key, the A DISPLAY shows ".0000pF", and the B DISPLAY shows "OPEN".

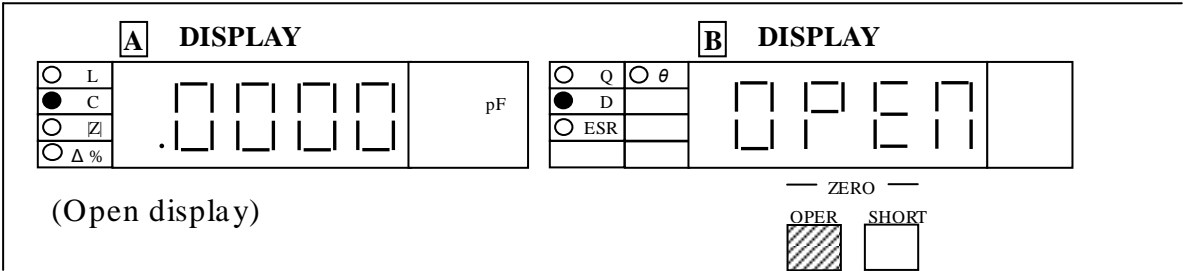

- Keep hands and objects at least 10cm from test fixture.
- Confirm the operation by pressing [OPEN] key again, or press any other keys to exit this. If [OPEN] key is pressed, the C indicator in A DISPLAY will flash during the procedure.

- Wait until the measurement is running again, indicates the open operation is successfully. If a "FAIL" message is shown, indicates a failure operation, and this open-circuit data will be ignored.

(3). Short Circuit:

- Short the test fixture with a clean copper wire (AWG 18 to 30), length 5 to 8cm

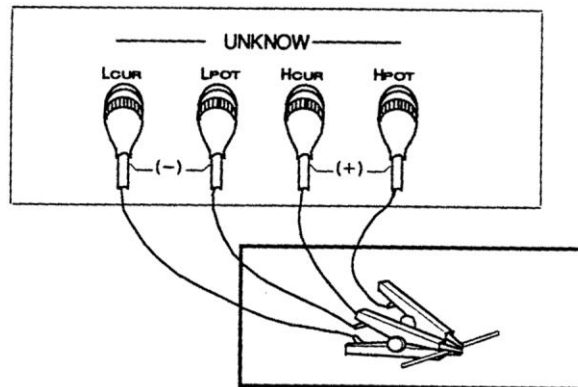

- Press [SHORT] key, the A DISPLAY shows ".0000Ω", and the B DISPLAY shows "Shot" (Short).

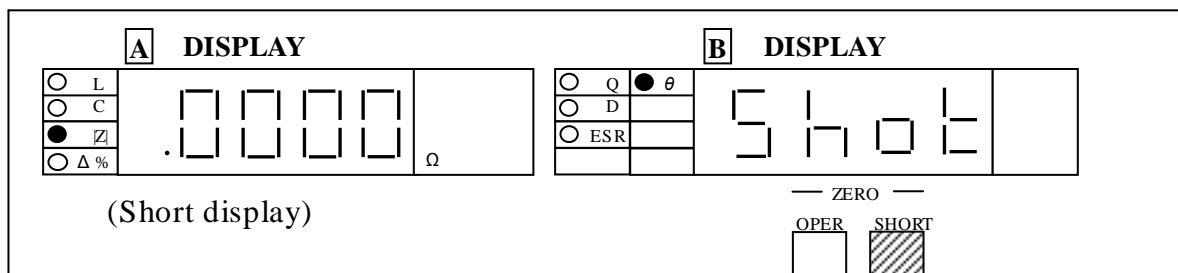

- Press the [SHORT] key again to confirm, or press any other keys to exit this. If [SHORT] key is pressed again, the |Z| indicator on A DISPLAY will flash during the procedure.
- Wait until the measurement is running again, indicates the short operation is successfully. If a "FALL" message is shown, indicates a failure operation, and this short-circuit data will be bypassed.
- Remove the short circuit.

NOTE

For best accuracy, repeat this zeroing procedure daily and after changing test fixture or frequency.

5.5 Routine Measurement

Select slow measurement rate for best accuracy, and equivalent SERIES circuit (see paragraph 5.6) as a general condition. Then connect the device to be tested with the instrument.

NOTE

Clean the leads of the DUT if they are noticeably dirty, even though the test fixture contacts will usually bite through a film of wax to provide adequate connections.

There are seven measurement parameter pairs available in the instrument, select one of the them for your specify.

(1). L and Q of an Inductor (L : .0000uH ~ 1999.9H, Q : .0000 ~ 19999)

Select A DISPLAY in L parameter by pressing [A DISPLAY] key, and select B DISPLAY in Q parameter by pressing [B DISPLAY] key. Place inductor in test fixture. The A DISPLAY shows Ls (series inductance) and units (uH, mH, H); the B DISPLAY shows Q (quality factor). If the value shown on A DISPLAY is negative, means the DUT is capacitive.

(2). L and D of an Inductor (L : .0000uH ~ 1999.9H, D : .0000 ~ 19999)

Select A DISPLAY in L parameter by pressing [A DISPLAY] key, and select B DISPLAY in D parameter by pressing [B DISPLAY] key. Place inductor in test fixture. The A DISPLAY shows Ls (series inductance) and units (uH, mH, H); the B DISPLAY shows D (dissipation factor). If the value shown on A DISPLAY is negative, means the DUT is capacitive.

- (3). L and R of an Inductor (L : .0000uH ~ 1999.9H, R : .0000mΩ ~ 19999kΩ)

Select A DISPLAY in L parameter by pressing [A DISPLAY] key, and select B DISPLAY in R parameter by pressing [B DISPLAY] key. Place inductor in test fixture. The A DISPLAY shows Ls (series inductance) and units (uH, mH, H); the B DISPLAY shows Rs (equivalent series resistance) and units (mΩ, Ω, kΩ). If the value shown on A DISPLAY is negative, means the DUT is capacitive.

WARNING

Charged capacitors may cause a hazard shock. Never handle their terminals if they have been charged to more than 60V.
Routine discharge procedures may not be perfectly dependable.

NOTE

That "high" terminals for (+) and "low" terminals for (-) polarity as marked on the front panel when polarized components is under tested.

- (4). C and Q of an Capacitor (C : .0000pF ~ 199.99mF, Q : .0000 ~ 19999)
Select A DISPLAY in C parameter by pressing [A DISPLAY] key, and select B DISPLAY in Q parameter by pressing [B DISPLAY] key. Place capacitor in test fixture. The A DISPLAY shows Cs (series capacitance) and units (mF, uF, nF, pF); the B DISPLAY shows Q (quality factor). If the value shown on A DISPLAY is negative, means the DUT is inductive.
- (5). C and D of an Capacitor (C : .0000pF ~ 199.99mF, D : .0000 ~ 19999)
Select A DISPLAY in C parameter by pressing [A DISPLAY] key, and select B DISPLAY in D parameter by pressing [B DISPLAY] key. Place capacitor in test fixture. The A DISPLAY shows Cs (series capacitance) and units (mF, uF, nF, pF); the B DISPLAY shows D (dissipation factor). If the value shown on A DISPLAY is negative, means the DUT is inductive.

(6). C and R of an Capacitor (C : .0000pF ~ 199.99mF, R : .0000m Ω ~ 19999k Ω)

Select A DISPLAY in C parameter by pressing [A DISPLAY] key, and select B DISPLAY in R parameter by pressing [B DISPLAY] key. Place capacitor in test fixture. The A DISPLAY shows Cs (series capacitance) and unit (mF, uF, nF, pF); the B DISPLAY shows Rs (equivalent series resistance) and unit (m Ω , Ω , k Ω). If the value shown on A DISPLAY is negative, means the DUT is inductive.

(7). |Z| and θ of Component (|Z| : .0000 Ω ~ 199.99M Ω , θ : -180.00 $^\circ$ ~ 179.99 $^\circ$)

Select A DISPLAY in |Z| parameter by pressing [A DISPLAY] key, and the B DISPLAY will display θ (phase angle) automatically ([B DISPLAY] key is inoperative now). Connect the component(s) or network to test fixture. The A DISPLAY shows |Z| (value of impedance) and units (Ω , k Ω , M Ω); the B DISPLAY shows θ (phase angle) and degree ($^\circ$). By convention, a positive phase angle implies an inductive impedance.

5.6 Equivalent Circuits -- Series, Parallel

The results L, or C (A DISPLAY) or R (B DISPLAY) measurements of many components depend on which of two equivalent circuits is chosen to represent it - series or parallel. As a general guide, series will be preferred for components whose impedance below 1000 ohms, and parallel for components exceed this value.

For a relatively pure component, the major term remains substantially the same in series or parallel representation. However, if D is high or Q low, Cs differs substantially from Cp and Ls differs substantially from Lp; and these values are frequency dependent. Usually several measurements at frequencies near the desired evaluation will reveal that either series measurements are less frequency dependent than parallel, or the converse. The equivalent circuit that is less frequency dependent is the better mode of the actual device.

The equivalent circuits are shown in the accompanying fixture, together with useful equations relating them. Notice that the instrument measures the equivalent series components L_s , C_s or R_s , if you select SERIES. It measures the parallel equivalent components L_p , C_p , or R_p if you select PARALLEL. D and Q have the same value regardless whether series or parallel equivalent circuits is calculated.

• Inductance and Resistance

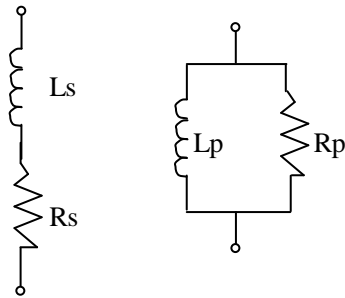

$$\omega = 2\pi f$$

$$Z = R_s + j\omega L_s$$

$$|Z_L| = \sqrt{R_s^2 + (\omega L)^2}$$

$$Q = \frac{1}{D} \quad Q = \frac{\omega L_s}{R_s} \quad Q = \frac{R_p}{\omega L_p}$$

$$L_p = \frac{1 + Q^2}{Q^2} L_s \quad L_p = (1 + D^2)L_s$$

$$R_p = (1 + Q^2)R_s$$

$$R_s = \frac{\omega L_s}{Q} \quad R_p = Q\omega L_p$$

$$R_s = |Z| \cos \theta$$

$$X_s = |Z| \sin \theta$$

$$D = \tan (90 - \theta)^\circ$$

$$Q = \cot (90 - \theta)^\circ$$

• Capacitance and Resistance

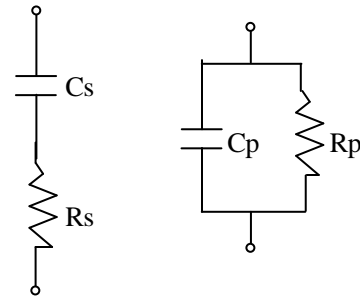

$$Z = R_s + \frac{1}{j\omega C_s}$$

$$|Z_C| = \sqrt{R_s^2 + \left(\frac{1}{\omega C_s}\right)^2}$$

$$D = \frac{1}{Q} \quad D = \omega C_s R_s \quad D = \frac{1}{\omega C_p R_p}$$

$$C_p = \frac{1}{1 + D^2} C_s$$

$$R_p = \frac{1 + D^2}{D^2} R_s$$

$$R_s = \frac{D}{\omega C_s} \quad R_p = \frac{1}{\omega C_p D}$$

There are some points worth to be noted:

- ESR for capacitors

The total loss of a capacitor can be expressed in several ways, including D and "Equivalent Series Resistance" (ESR), which is designated " R_s " in the preceding paragraph. If you want ESR display simultaneously with C_s , be sure that the PARALLEL/SERIES on-key LED is lit; and select A,B DISPLAY in "C" and "R" display. "ESR" is typically much larger than the actual ohmic series resistance of the wire leads and foils that are physically in series with the heart of a capacitor, because ESR includes also the effect of dielectric loss. ESR is related to D by the formula $ESR = R_s = D/(2\pi fC_s)$

- Equivalent circuit for inductors

The SERIES circuit is appropriate for small "air-core" inductors, which the significant loss mechanism is usually "ohmic" or "copper loss" in the wire. And the PARALLEL circuit is appropriate for "iron-core" inductors, which the significant loss mechanism may be "core loss" (caused by eddy currents and hysteresis).

5.7 Display Messages

There are some message used in the meter during the measurement procedure.

- (1) "----" : Indicates an invalid measurement range selection
- (2) "UUUU" : Indicates the impedance of unknown exceeds the measurement range.
- (3) AUTO indicator flash: Indicates a non-best range held.
- (4) "GP-E" : GPIB command or handshake process error.

5.8 Comparator

5.8.1 Introduction to COMPARATOR

To judge the parts in GO/NO-GO usually needs to set up limits of principal parameter (L/C/|Z|) and secondary parameter (Q/D/R/ θ). The instrument provides two 5-digit and two 3-digit thumb switches for setting of these of these limits.

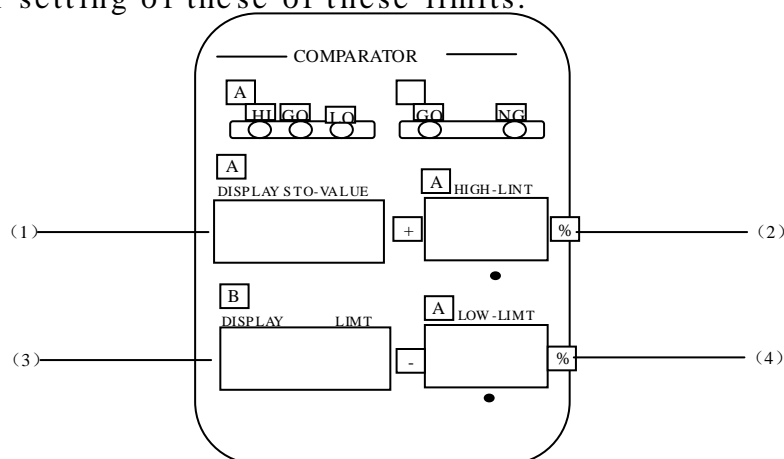

These switch are:

(1). A DISPLAY STD. VALUE:

5-digit thumb switches, but range up to 19999. For setting standard (nominal) value of principal parameter (L/C/|Z| shown on A DISPLAY). The decimal point and unit are set in limit entry procedure by RANGE [AUTO][◀][▶] keys.

(2). A HIGH-LIMIT:

3-digit thumb switches. For setting high-limit (%) of principal parameter. The decimal point is fixed and the sign is positive. Setting range is from +00.0% to + 99.9%.

(3). A LOW-LIMIT:

3-digit thumb switches. For setting low-limit (%) of principal parameter. The decimal point is fixed and the sign is negative. Setting range is from -99.9% to - 00.0%.

(4). B DISPLAY LIMIT:

5-digit thumb switches, but range up to 19999. For setting limit of secondary parameter (Q/D/R/ θ shown on B DISPLAY). The limit is high-limit (absolute value for D, ESR(R_s) and θ , low-limit for Q and EPR(R_p).The decimal point and unit (when R is measured) are set in limit entry procedure by [B DISPLAY] key.

(5). Judgment method

There are two groups of judgment indicators in the COMPARATOR. [A] HI-GO-LO and [B] GO-NG. If the COMPARATOR is enabled ([COMP.ENABLE] key is pressed to on-key LED lit), the measured value will be compared with the limits. And these indicators will show the compared results. The figures illustrate the method of judgment.

LC/|Z| results
(A DISPLAY)

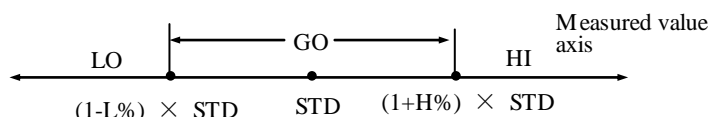

where

H%= High-limit percentage

L%= Low-limit percentage

STD= Standard value

QDR θ results
(B DISPLAY)

1. When Q or EPR (R in PARALLEL mode) is measured.

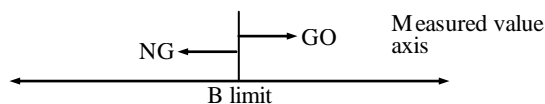

2. When D or ESR (R in SERISE mode) is measured.

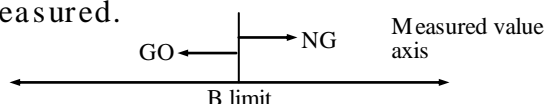

3. When |Z| - θ is measured.

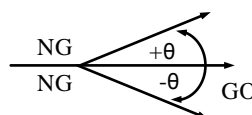

5.8.3 Limit Comparison Measurement

Before limit entry procedure, first select all measurement conditions ready to measure as follows:

Example: L-100uH, $\pm 20\%$ (air - core)

Q – Greater than 20

Measurement signal – 10KHz, 10mA

Fast RATE, Internal TRIGGER.

- (1). Select principal parameter by [A DISPLAY] key in L.
- (2). Select secondary parameter by [B DISPLAY] key in Q.
- (3). Select the measurement frequency in 10KHz and the measurement voltage in 0.1V (correspond to 10mA in range 1 and 2). Refer to paragraph 5.2.
- (4). Find the equivalent impedance of 100uH in 10KHz ($2\pi fL \approx 6.28\Omega$) out from Figure 2-1 (C), and hold the measurement range in range 2 according to the range select reference table 2-3. Select the range by RANGE [◀] [▶] keys.
- (5). Select the TRIGGER mode in Internal by [INT] key.
- (6). Select the RATE in fast (rates near 13 measurements per second).
- (7). Select the equivalent circuit mode in SERIES for an air-core (Refer to paragraph 5.6).
- (8). Connecting the test fixture and operating the zeroing process as described in paragraph 5.4 .

After all the conditions are ready, it is recommended to connect a real DUT to be measured. If any error or no-good message as listed in paragraph 5.7, check the procedures above and change the error setting if needed.

If all the conditions normal, then enter the limit value for comparison as described in next paragraph.

5.8.4 Limit Entry Procedure

To enable comparisons, first press [COMP.ENABLE] key, and the instrument Comes into the limit entry procedure as follows:

- (1). Press [COMP.ENABLE] key, the on-key LED is lit and flash. The A DISPLAY show the set STD.VALUE with decimal point and unit, and wait for entry of standard value. Push the thumb switches to enter the numbers, adjust the decimal point by [AUTO] key and select unit by RANGE [◀] [▶] keys.

Example:100uH

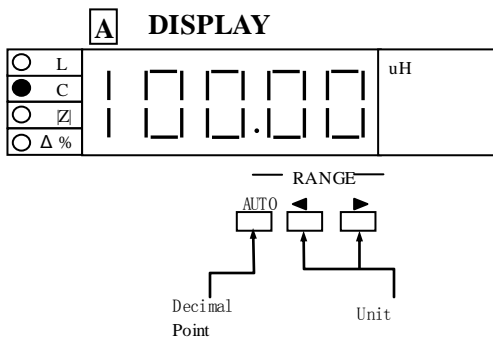

Notice: The set number range is up to 19999 counts. If set over this range the A DISPLAY will show “----” flash message for an invalid entry

- (2). Press [COMP.ENABLE] key again to read-in the set standard value and the instrument come into the high, low limits setting procedure . The set [A] HIGH LIMIT switches will be show on A DISPLAY and the set [A] LOW LIMIT switches on B DISPLAY.

Example: $\pm 20\%$

A DISPLAY		B DISPLAY	
<input type="radio"/> L	20.0%	<input type="radio"/> Q	<input type="radio"/> θ
<input checked="" type="radio"/> C		<input checked="" type="radio"/> D	<input type="radio"/> V
<input type="radio"/> Z		<input type="radio"/> ESR	<input type="radio"/> I
<input type="radio"/> $\Delta\%$		<input type="radio"/> $\Delta\%$	
		- 20.0%	

Push the thumb switches to enter the percentage limit, and the decimal Point is fixed.

- (3). Press [COMP.ENABLE] key again to read-in the high low limit, and the instrument comes into secondary parameter limit setting procedure. The set [B] DISPLAY LIMIT switches will be show on B DISPLAY with decimal point (and unit id R is measured).

Example: $\cong 20$

Push the thumb switches to enter the numbers and adjust the decimal point (and unit if R id measured). By [B DISPLAY] key.

B DISPLAY	
<input type="radio"/> Q	<input type="radio"/> θ
<input checked="" type="radio"/> D	<input type="radio"/> V
<input type="radio"/> ESR	<input type="radio"/> I
<input type="radio"/> $\Delta\%$	
.... 20.0%	

Notice the same setting limit as described in procedure(1).

- (4). Press [COMP.ENABLE] key once more to complete the entry procedure and the [COMP.ENABLE] on-key will stop flashing and keep lit. Then the instrument is operated under limit-comparison mode, and the judgment indicators will indicate the result.

5.8.5 Notes in Limit-comparison Mode.

(1). To exit the limit-comparison mode, press the [COM.ENABLE] key twice continuously.

(2). The function keys are changed as:

a. [A DISPLAY] : Selection of displays for value or deviation % (Δ %),
Two indicators are lit simultaneously for deviation %
(ex. L and Δ %).

b. [RATE] : Not changed.

c. RANGE : Inoperative.

[AUTO][◀][▶]

[PARA.SER]

[B DISPALY]

ZERO

[OPEN][SHORT]

[LOCAL]

[FREQ.VOLT.]

[▲][▼]

d. TRIGGER : Not changed.

[INT][EXT.MAN]

(3). If any of the thumb switches is changed during measurement process, the instrument will stop measuring to run the limits entry procedure. DO NOT push the switches unless change limits setting is necessary.

(4). If turn off the instrument under limit-comparison mode, the set conditions and limits (decimal points and units) will be memorized by battery back up. But if any of the thumb switches is changed during the power off period, the instrument will excute the limits entry process automatically after power up routine.

- (5). Setting the standard value to 100.00uH, 100.0uH, 100uH, 0.1mH ... are all the same meaning to the instrument. But it is recommended to connect a real DUT to be measured, the instrument will show the position of decimal point and unit in propriety ; and avoid the error setting in next because of wrong unit or decimal point position.
- (6). If the HANDLER INTERFACE is equipped , all the judgment results are output from the interface.

6.1 GENERAL

Using the IEEE-488 INTERFACE, you can operate the meter by remote control, transfer data, etc.

6.2 IEEE-488 INTERFACE SPECIFICATION

6.2.1 Applicable Standard

IEEE std 488-1978

6.2.2 IEEE-488 INTERFACE Function

Table 6-1 IEEE-488 INTERFACE Function of The Meter

Code	Meaning
SH1	Source handshake (talker)
AH1	Acceptor handshake (listener)
T5	Basic talker function
	Serial poll function
	Listener-specified talker release function
	Talk-only mode
L4	Basic listener function
	Talker-specified listener release function
	No listen-only mode
SR1	All service request functions
RL1	All remote-local functions
PP0	No parallel poll functions
DC1	Device clear function
DT1	Device trigger function
C0	No controller functions

6.2.3 Using code

ISO (ASCII) code

6.2.4 ADDRESS DIP switch (Rear)

The DIP switch is used to set address Talk mode of the meter, setting range of address is 0 ~30. The default is 3. If address change is needed, use minus screwdriver to slide switches as setting.

The set address value is the sum of switched value, as a example 9 :

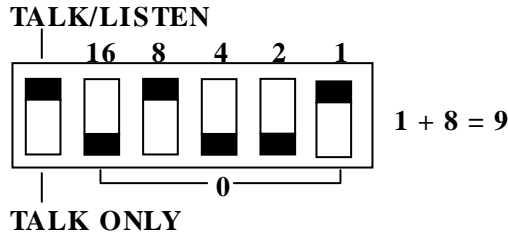

6.2.5 TALK ONLY and TALK/LISTEN functions

This instrument will function as TALK/LISTEN or a TALK ONLY device in the system, depending on the position of TALK switch (included in ADDRESS DIP witch). "TALK/LISTEN" denotes full programmability and is suited for use in a system that has a controller or computer to manage the data flow. TALK ONLY is suited to a simply system - e.g meter and printer - with no controller and no other talker. Either mode provides measurement results to the listeners in the system.

6.2.6 The IEEE-488 INTERFACE connector

- Pin configuration of the meter side connector is as shown below.

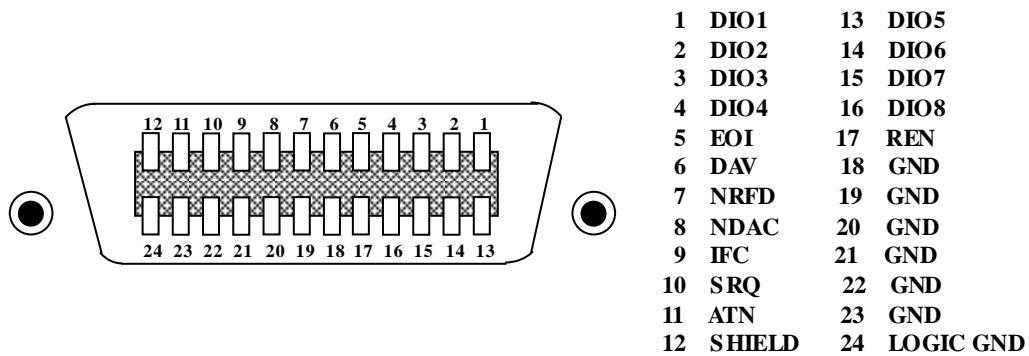

- Meter side connector
DDK 57LE-20240 or equivalent
- Cable side connector
DDK 57-10240 or equivalent

6.2.7 Signal Lines of the IEEE 488 Interface Bus

- The interface is composed of the data bus, the handshake bus and the control bus shown in the table below.

Bus Signal Lines		Description
Data Bus	DIO 1 (Data Input Output1) 2 (Data Input Output2) 3 (Data Input Output3) 4 (Data Input Output4) 5 (Data Input Output5) 6 (Data Input Output6) 7 (Data Input Output7) 8 (Data Input Output8)	<ul style="list-style-type: none"> • Besides data input, it is used for interface and device message input/output.
Handshake Bus	DAC (Data Valid) NRFD (Not Ready For Data) NDAC (Not Data Accepted)	<ul style="list-style-type: none"> • Indicates that data on the data bus are valid. • Indicates that the listener side is ready to receive. • Indicates that the listener side has finished data reception.
Control Bus	ATN (Attention) REN (Remote Enable) IFC (Interface Clear) SRQ (Service Request) EOI (End Of Identify)	<ul style="list-style-type: none"> • Indicates whether the signal on the data bus carries data or an interface or device message. • Switches between the remote and local control modes. • Used to reset the interface. • Signal sent by the talker side to call the controller. • Indicates the end of data.

6.2.8 Response to Interface Messages

- The meter is capable of responding to the following messages.

Interface Message	Response
GET (Group Execute Trigger)	<ul style="list-style-type: none"> • Allows triggering only for addressed devices. • Starts measurement, then holds the reading when measurement is completed. The hold mode is released by reading the value.
GTL (Go To Local)	<ul style="list-style-type: none"> • Only addressed devices that receive this command are set to local mode. • Cancels the remote control mode, making front panel switches operative.
SDC (Selected Device Clear)	<ul style="list-style-type: none"> • Only addressed devices that receive this command are cleared. • The meter activates as power-up again.
DCL (Device Clear)	<ul style="list-style-type: none"> • Clear all devices on the bus. • The meter activates as power-up again.
LLO (Local LockOut)	<ul style="list-style-type: none"> • Disable the local switch function of all devices on the IEEE-488 interface bus. • Make all switches on the instrument front panel lose efficacy.

6.2.9 Bus Driver

- Specifications of the meter bus driver are shown in the table below.

DIO1 - 8 SRQ NRFD NDAC	Open collector
EOI REN DAV IFC ATN	3 states

6.3 LISTENER FUNCTION

6.3.1 General

All the front panel functions of the meter can be operated by remote commands. The input command string are composed by { [Command + parameter]s + End Code } with ASCII code. Between instructions (command + parameter) is no delimiter required or delimit with a space ". The length of the command string is limited in 20 characters. Any error command input occurred, the meter will show a "GP-E" message on A DISPLAY for that.

6.3.2 Command list

COMMANDS USED IN PROGRAMMING VIA IEEE-488 INTERFACE BUS

Program Category	Program Selection	Command Type	Command Entry
A DISPLAY	Value	2 byte	D0
	Deviation %	2 byte	D1
PRESET Display	FREQUENCY	2 byte	O0
	VOLTage	2 byte	O0
Measurement Rate	Fast	2 byte	S0
	Slow	2 byte	S1
Measurement Voltage	Value (in volts) = v	Floating	Vv;
Parameter	Inductance (L/Q)	2 byte	M0
	Capacitance (C/D)	2 byte	M1
	Capacitance (C/R)	2 byte	M2
	Impedance (Z/θ)	2 byte	M3
	Inductance (L/D)	2 byte	M4
	Inductance (L/R)	2 byte	M5
Equivalent Circuit	Parallel	2 byte	C0
	Series	2 byte	C1

(continued on next page)

6 IEEE-488 INTERFACE (OPTIONAL)

(continued)

COMMANDS USED IN PROGRAMMING VIA IEEE-488 INTERFACE BUS

Program Category	Program Selection	Command Type	Command Entry
Range Control	Hold range	2 byte	R0
	Hold range1	2 byte	R1
	Hold range2	2 byte	R2
	Hold range3	2 byte	R3
	Hold range4	2 byte	R4
	Hold range5	2 byte	R5
	Hold range6	2 byte	R6
	Hold range7	2 byte	R7
	Hold range8	2 byte	R8
	Auto-range	2 byte	R9
Frequency	Value (in kHz) = f	Floating point	Ff;
Zero Calibration	Disable	2 byte	Z0
	Enable open	2 byte	Z1
	Enable short	2 byte	Z2
A DISPLAY Standard Value	Value (in ohms, henries farads) = n	Floating point	Nn;
B DISPLAY Limit Value	Value (Dimensionless for Q or D or θ , ohms for R) = b	Floating point	Bb;
Limit Entry	High limit (in %) = h	Floating point	Hh;
	Low limit (in %) = l	Floating point	Ll;
Initiation	Start a measurement	2 byte	G0
Manual Trigger	Enable key	2 byte	W0
	Disable key	2 byte	W1
Comparator Function	ON	2 byte	Q0
	OFF	2 byte	Q1

6.4 Talker Function

6.4.1 Basic talker function

The measured result of the meter will be sent to the IEEE-488 INTERFACE bus when the meter is specified as a talker. The output format is :

DATA OUTPUT FORMAT

Character Sequence	Purpose	Allowed Characters	Meaning
1	Status	(space) E O I U	Normal operation, measurement on a basic range Error-range held (reduce accuracy) ** like AUTO-FLASH message ** Over-range held of range 3,4,5,6,7,8 ** like "UUUU" message ** Invalid range selection** like "----" message ** The data is not yet refreshed by new Measurement
2	Format	(space)	
3	A-Parameter	L C Z	Inductance Capacitance Impedance
4	Format	(space)	
5,6	A-Units	(space)H mH uH mF uF nF pF (space)O KO MO (space)%	Henries Millihenries Microhenries Millifarads Microfarads Nanofarads Picofarads Ohms Kilohms Megohms Percentage difference from standard value
7	Format	(space)	

(continued next page)

6 IEEE-488 INTERFACE (OPTIONAL)
(continued)

DATA OUTPUT FORMAT

Character Sequence	Perpose	Allowed Characters	Meaning
8	A- Sign	(space) -	Positive L, C, Z or deviation % Negative L, C, Z or deviation %
9...14	A-Number	0123456789. (space)	Measured L/C/Z number, right justified in format field; like the A DISPLAY except the zero before the decimal point is explicitly provided and this number can be as long as six character 999999 for "----" and "UUUU".
15	Format	(space)	
16	B- Parameter	Q D R S	Quility factor Dissipation factor Resistance Phase angle (θ)
17	Format	(space)	
18,19	B-Units	mO (space)O KO (2 spaces)	Milliohms Omhs Kilohms Dimensionless (for Q,D, θ)
20	Format	(space)	
21	B-Sign	(space) -	Positive Q, D, R, θ Negative Q,D,R, θ
22...27	B-Number	0123456789. (space)	Measured Q/D/R/ θ number, right justified in format field; like the A DISPLAY except the zero before the decimal point is explicitly provided and this number can be as long as six characters. 999999 for "----" and "UUUU"

(continued on next page)

6 IEEE-488 INTERFACE (OPTIONNAL)

(continued)

DATA OUTPUT FORMAT

Character Sequence	Perpose	Allowed Characters	Meaning
28*	Format	(space)	
29*	A-Parameter	0	Good
	H/GO/LO	1	Low
		2	High
30*	B-Parameter	0	Good
	GO/NG	1	No Good
(28)31		(CR)	The standard “carrige return”and
(29)32	Delimiter	(LF)	“line feed” characters; end of string

* : Output when comparator function ON only.

6.4.2 Status byte output format

- The status byte indicates the internal condition of the meter. It is output when a serial poll is excuted by the controller.
- The meaning and value of each bit of status byte are shown below. When the controller performs a serial poll and reads the status byte, the meter output the sum of all set bits.

Bit	Value	Condition	Meaning
0	0		
1	2	B valid	QDR θ measured value is available.
2	4	A valid	LCZ measured value is available.
3	0		
4	16	Busy	Measurement in process.
5	32	Zero fail	OPEN/SHORT zeroing fail during process.
6	64	SRQ	Request for service.
7	128	Remote	Remote controlled.

7.1 GENERAL

If you have the HANDLER INTERFACE option, connect from the HANDLER INTERFACE on the rear panel to a handler. Connect the control lines to the handler. See Table 7-1. As indicated in the specifications at the front of this manual, the output signal come from open-collector drivers that pull each signal line to a low voltage when that signal is active and let it float when inactive. Each external circuit must be powered by a positive voltage, up to 30V(max), with sufficient impedance(pull – up resistors) to limit the active-signal (logic-low) current to 16mA(max).

CAUTION

Each relay or other inductive load requires a CLAMPING DIODE (rectifier) across it (cathode connected to the power-supply end of the load) typically.

Table 7-1

HANDLER INTERFACE KEY

Signal		
Name	Pin No.	Function (All signal “active low”)
	5.6.7	Ground connection.
	10	DC bus (+5v) available; commonly for opto-couplers. Limit the load to 25mA(max).
START	1	Initiates measurement (External Trigger).
EOM	18	“End of measurement”; judgment signals are valid.
ACQ OVER	22	“Data acquisition over”; DUT removal OK.
A GO	21	L/C/ Z Good.
A LO	3	L/C/ Z too low.
A HI	4	L/C/ Z too high
A NG	13	L/C/ Z No-Good (too high or too low).
B GO	19	Q/D/R/θ Good.
B NG	15	Q/D/R/θ No-Good.

The input signal is also active low and also requires a positive-voltage external circuit, which must pull the signal line down below 0.4v, but not less than 0v, ie., not negative. The logic-low current is 0.4mA(max). For the inactive state logic high the external circuit must pull the signal line above +2.5v, but not above +5v.

7.2 TIMING

All the control are enabled only if the COMPARTOR is enabled.

Refer to the following figure for timing guideline the. Notice the START Must have a duration of 1 uS (minimum) in each state (high and low). If START is provided by a mechanical switch without debounce circuitry, the instrument may make many false starts.

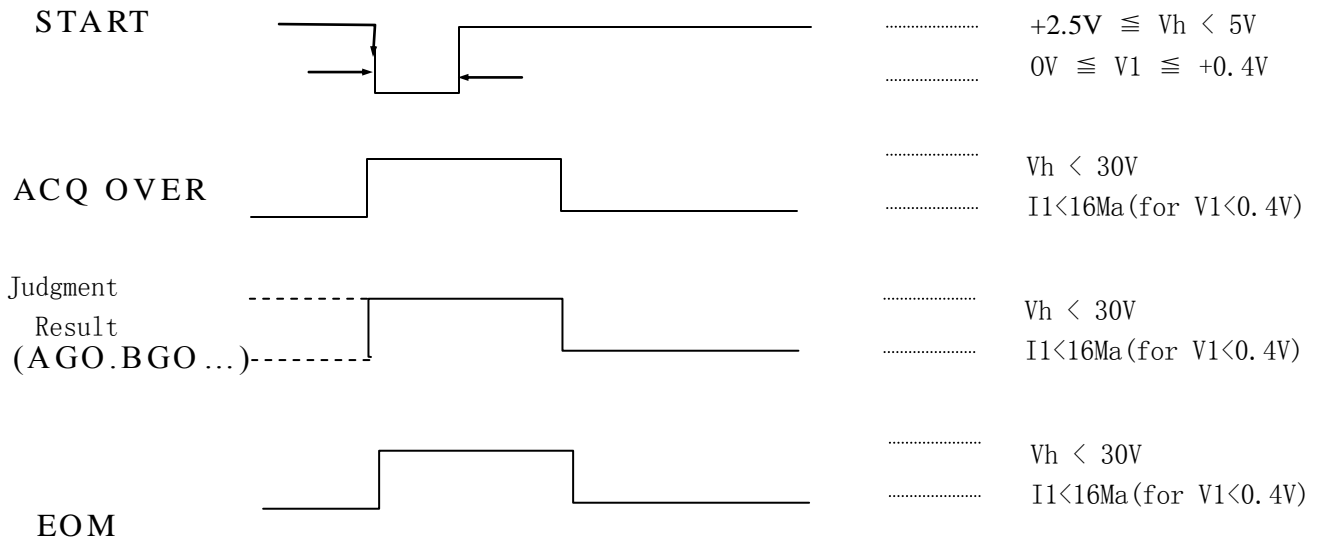

Figure 7-1 Handler interface timing diagram.

Measurement starts at time C, which is essentially the same as time a; measurement is completed at f. (The START signals are expanded for clarity.) Interval a-b, during which the DUT must remain connected for data acquisition, is considerably shorter than the total measurement time a-f. The DUT can be changed after d (“indexing on ACQ”, to save time) or after f (“indexing on EOM”, for a simply measurement setup), as explained below.

After the calculation interval d-e, measurement results are available for judgment and active lines goes low. A few Usec later, EOM goes low (can be used to latch holding the result assignment). ACQ OVER, the active result lines, and EOM then stay low until the next start command. The time required for measurement, refer to paragraph 2.6.

Set up the handler either of two ways: index on EOM or index on ACQ, as follows. The handler must supply a signal to initiate measurement when it has completed connection of the DUT to the test fixture.

(1). Indexing on EOM.

Set up the handler to respond to the EOM signal from the instrument, Which occurs at the “end of measurement”, when the judgment result is available. Set up the meter to receive its START signal from the handler’s “start measurement” signal. This setup is simpler than the one below.

(2). Indexing on ACQ.

Set up the handler to respond to the ACQ OVER signal from the Instrument, which occur when the “data acquisition” is complete. The handler can then remove the DUT from the test fixture and replace it with another DUT, while the meter is calculating the result. This setup results in higher measurement rate than rate than indexing on EOM.

一. 面板功能说明

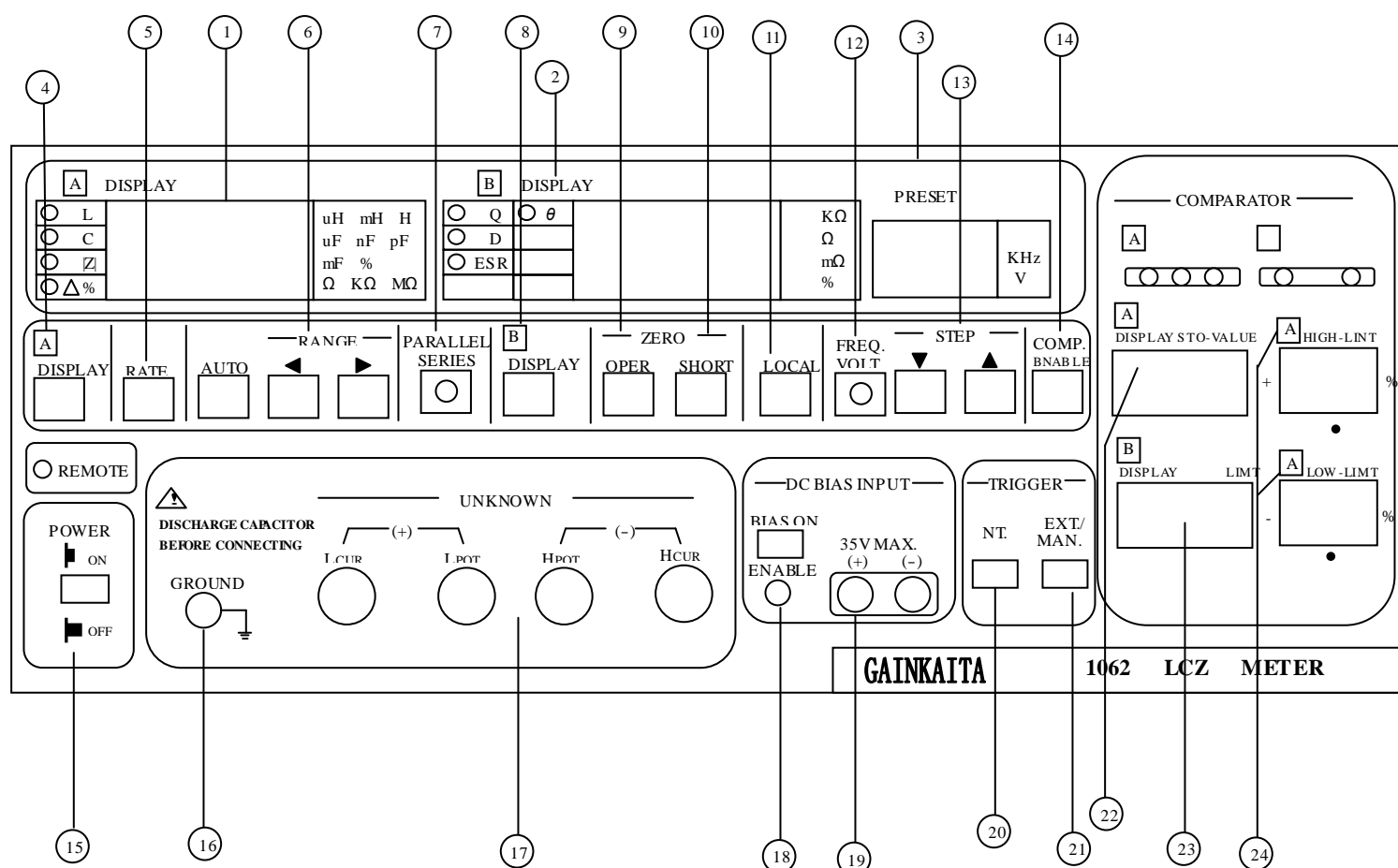

(1). **A** DISPLAY : L. C. |Z|, Δ% 数值显示.

(2). **B** DISPLAY : Q. D. R. θ 数值显示.

(3). PRESET : 测试频率电压显示.

A COMP.
 (4). DISPLAY 键 : 选择 L 或 C 或 |Z|, 在 ENABLE 键 ON 时选择数值或 Δ%.

(5). RATE 键 : 测试速率选择键, 共有三种速率可选: 约每秒测量 8 次, 2.5 次, 1 次.

(6). RANGE 选择键 : AUTO 键为自动选档. ◀ 键为向左方单位移动.
 ▶ 键为向右方单位移动.

- (7). PARALLEL 选择键 : 串并联等效电路选择, 灯亮为串联, 不亮为并联.(一般阻抗
SERIES 低于 $1K\Omega$ 使用串联, 高于 $1K\Omega$ 则使用并联-PARALLEL) .
- (8). \boxed{B} DISPLAY 键 : 选择 Q. D. R 等功能, 在(4). \boxed{A} DISPLAY 键选择 $|Z|$ 时,
自动显示 θ .
- (9). OPEN 键 : 开路归零执行键, 测试端开路, 按一次出现 "C .0000pF"
"OPEN"提示显示幕, 再按一次确认执行.
- (10). SHORT 键 : 短路归零执行键, 测试端短路, 按一次出现 " $|Z|$.0000 Ω "
"Sho(r)t"提示显示幕, 再按一次确认执行.
- (11). LOCAL 键 : 以 GPIB 连线控制时, 按 LOCAL 键可改由仪器面板操作.
- (12). FREQ. VOLT 键 : 频率电压显示选择键, 灯亮为电压, 不亮为频率.
- (13). STEP 键 : 频率电压调整键, 视 FREQ. VOLT 键而定, 以 \blacktriangle 上升键,
 \blacktriangledown 下降键来调整.
- (14). COMP.
ENABLE 键 : 比较器功能设定执行键, 灯亮表示进入比较状态.
- (15). POWER 键 : 电源开关, \blacksquare 开, \blacksquare 关.
- (16). GROUND : 接地端子. 此端子与本机器外壳连接, 请连接至大地及测量
治具之隔离体.
- (17). UNKNOWN : 测试端子. 红色测试线两条一组接右侧, 黑色测试线两条一
组接左侧.

- (18). ENABLE : 外接偏压开关. 使用外加偏压时, 请以小型起子伸入调整至 BIAS ON 灯亮.
- (19). (+) (-) : 外加偏压输入端子.(请注意极性是否正确)
- (20). INT. 键 : 内部连续触发测试.
- (21). EXT./MAN.键 : 外部单一触发测试.
- (22). DISPLAY STD-VALUE : DISPLAY 标准值输入指拨开关.(00000~19999)
- (23). DISPLAY LIMIT : DISPLAY 上限或下限输入指拨开关.
- (23). HIGH-LIMIT : DISPLAY 上限输入指拨开关.
- LOW-LIMIT : DISPLAY 下限输入指拨开关.

二. 操作说明

(一). L.C.Z 1062 操作程序

(1). 插上电源 : 并先确认输入电压是否正确. (110V 或 220V)

(2). 开机 : 电源开关 ON → 显示 1062 及上次关机前状态.

新机出厂通常为 RANGE → AUTO 测试迦路 → SERIES(串联)
测试 → INT(内部触发).

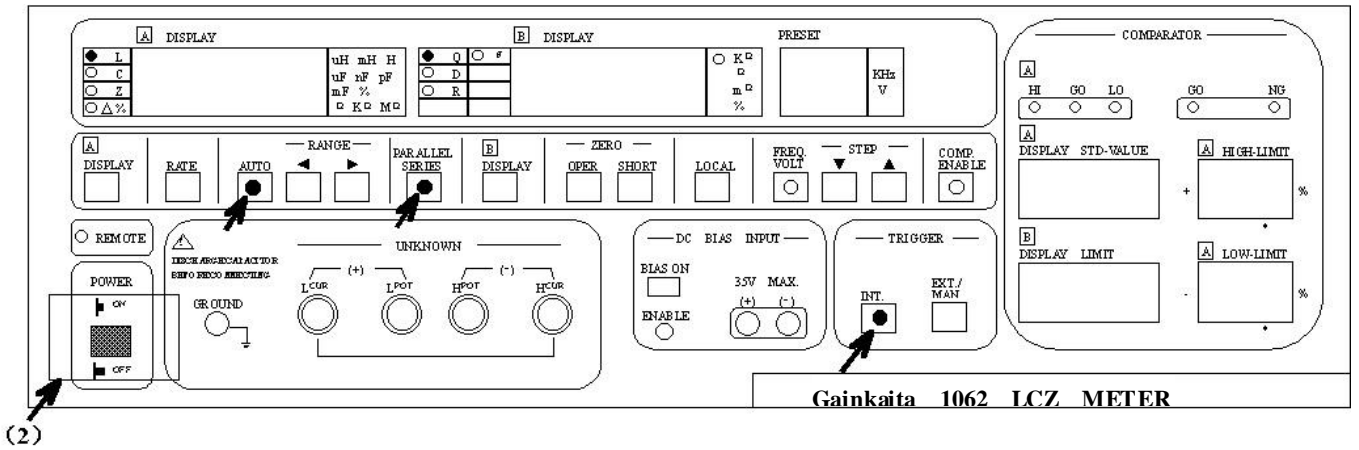

(3). 选择测试元件参数 : 按 [A] DISPLAY 键选择 L 或 C 或 |Z|, 按 [B] DISPLAY 键选择 Q 或 D 或 R. 若 [A] DISPLAY 选至 |Z|, 则 [B] DISPLAY 自动跳到 θ .

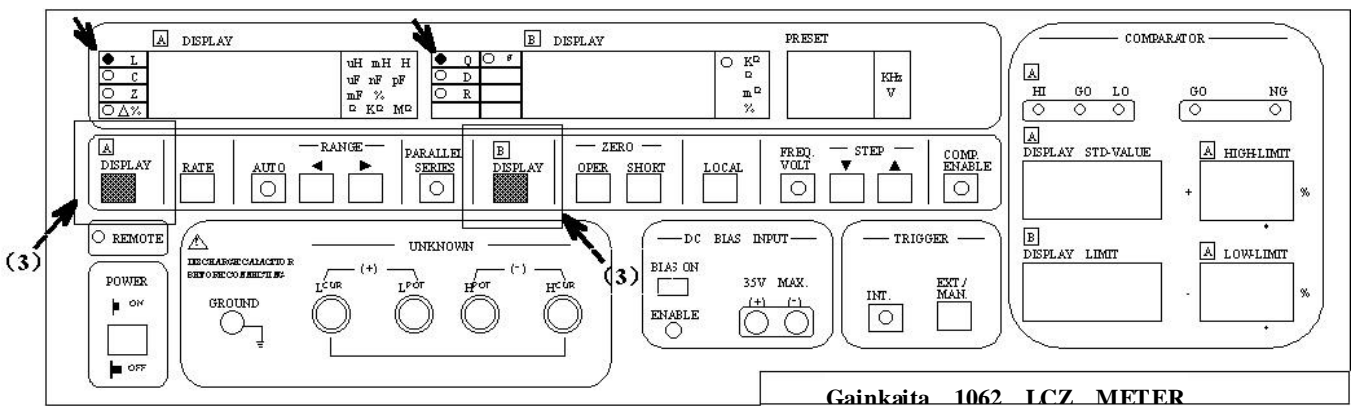

- (4). 设定测试频率电压：按 **FREQ./VOLT** 键，并以 **STEP** 中的▲上升键，▼下降键来设定所需之频率或电压值。

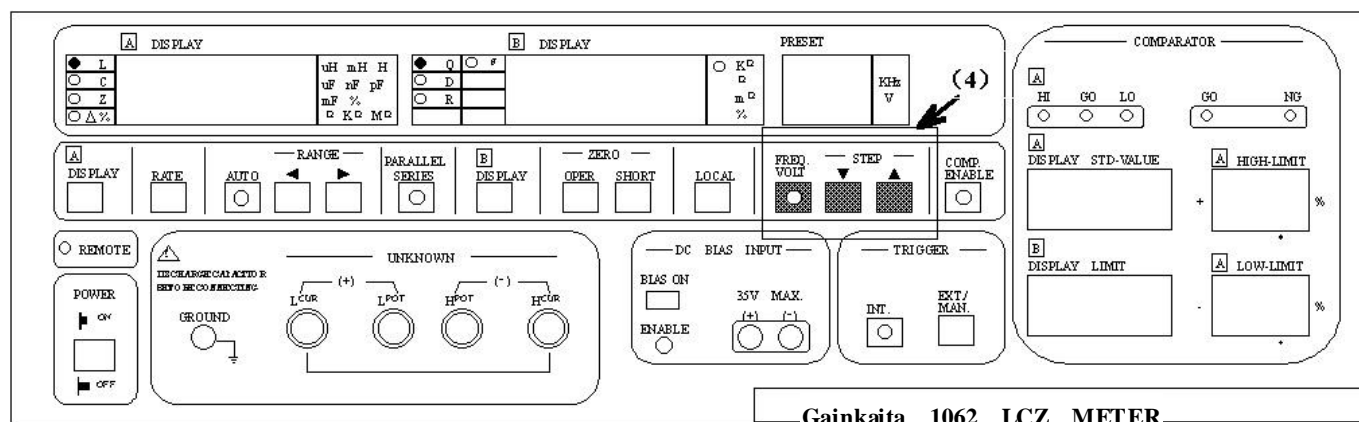

- (5). 归零：在参数频率电压确认设定无误后做，归零校正。

- a. 开路归零：将测试端开路，按 **OPEN** 键两次，即执行归零程序，恢复测试状态即代表归零 OK！在慢速时，最后两位有残值或跳动值乃正常现象。
- b. 短路归零：将测试端短路，按 **SHORT** 键两次，即执行归零程序，恢复测试状态即代表归零 OK！在慢速时，最后两位有残值或跳动值乃正常现象。

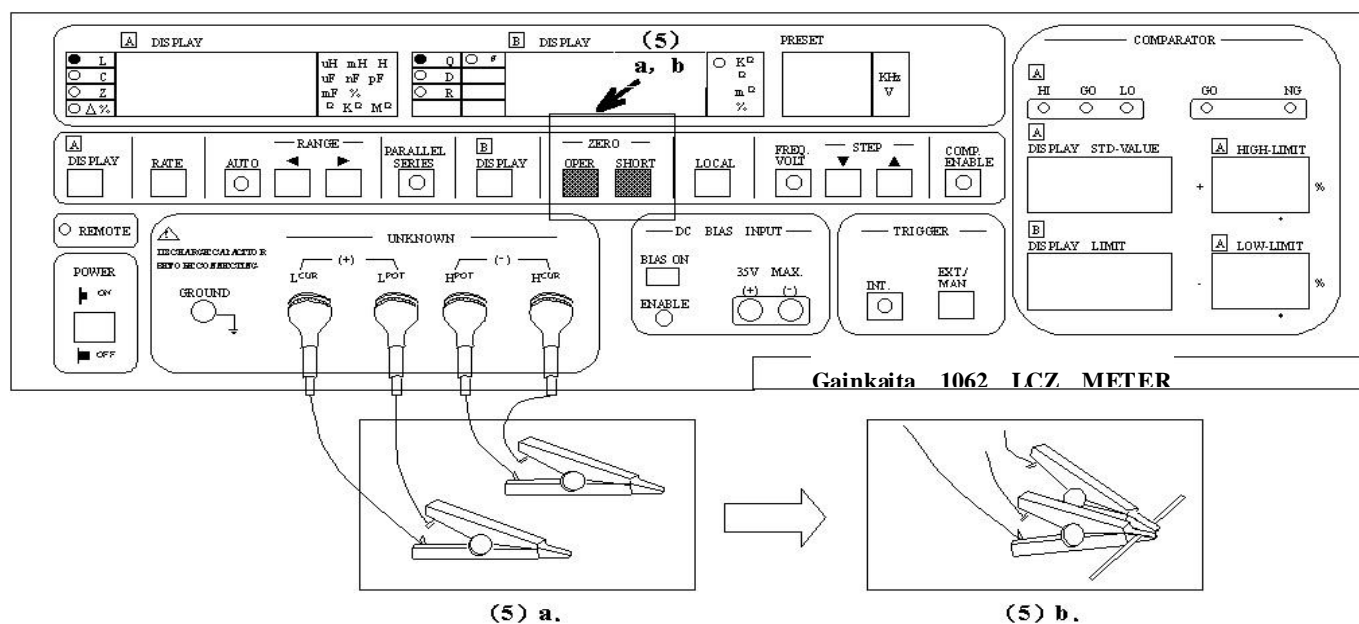

- (6). 测试：将待测物接在测试端即可测得所需参数。

(二). 比较器之设定使用

1. 比较器功能：(1). 设定标准值及上下限，以灯号显示，蜂鸣器响声，做良品之分类品管检验。

(2). 可显示测试值或误差百分比。

2. 设定方式：

- 直接输入法：以 $100\mu\text{H} \pm 5\%$ Q 值 6 以上为例。

(1). 按 **ENALBE/COMP.** 键 $\xrightarrow{\text{显示}}$ Std-Lmt $\xrightarrow{\text{显示}}$ “**DSPLAY STD-VALUE**” 及 “**DSPLAY LIMIT**”，指拨开关的数字。

(2). 先设定感量标准值，将 **DSPLAY STD-VALUE** 指拨开关拨为 10000 或 01000 或 00100 或 00010 或 00001(以第一者较合适)，此时 **DISPLAY** 会同时显示指拨开关的数字。

(3). 以 **RANGE** \blacktriangleleft \blacktriangleright 键选择标准单位，此例为 μH 。

(4). 以 **AUTO** 键移动小数点至正确位置。

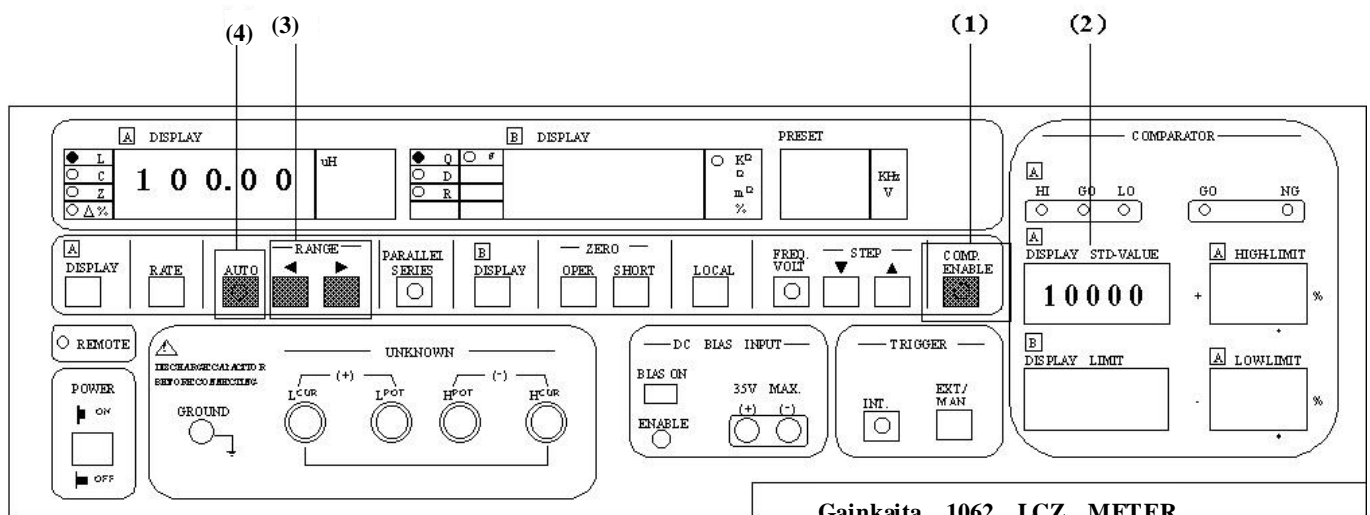

- (5). 设 Q 值将 DISPLAY LIMIT 指拨开关拨为 06000 或 00600 或 00060 或 00006(前二者较合适).

- (6). 以 **B** DISPLAY 键移动小数点至正确位置.

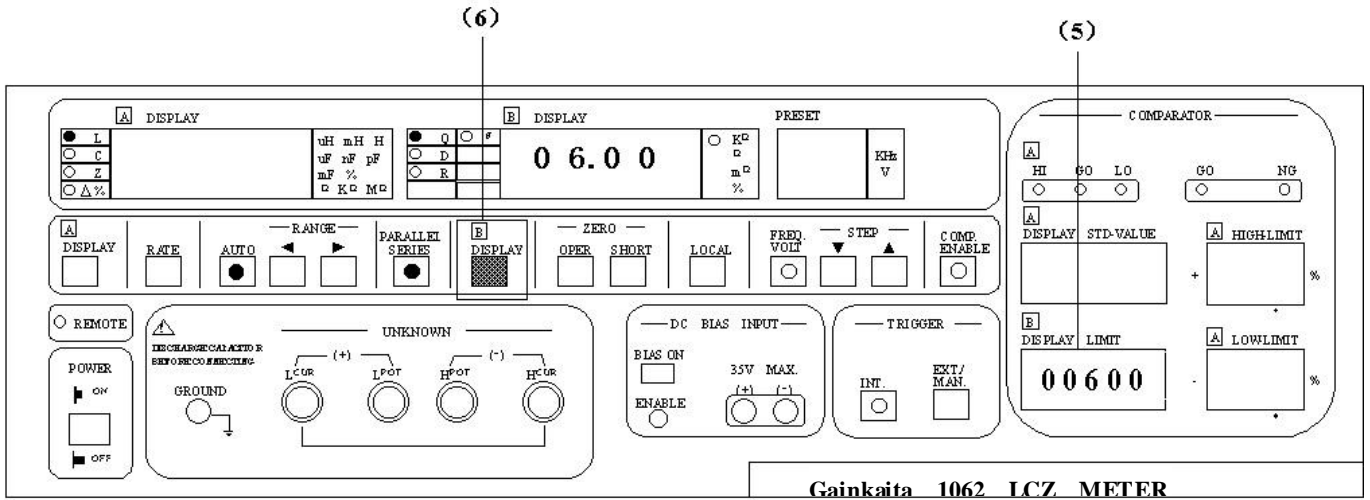

- (7). 再按 ENABLE/COMP. 键 $\xrightarrow{\text{显示}}$ HI-LO $\xrightarrow{\text{显示}}$ **A** HIGH-LIMIT 及 **A** LOW-LIMIT 指拨开关的数字.

- (8). 按 **A** HIGH-LIMIT “指拨开关”设定所需上限百分比 05.0.

- (9). 按 **A** LOW-LIMIT “指拨开关”设定所需上限百分比 05.0.

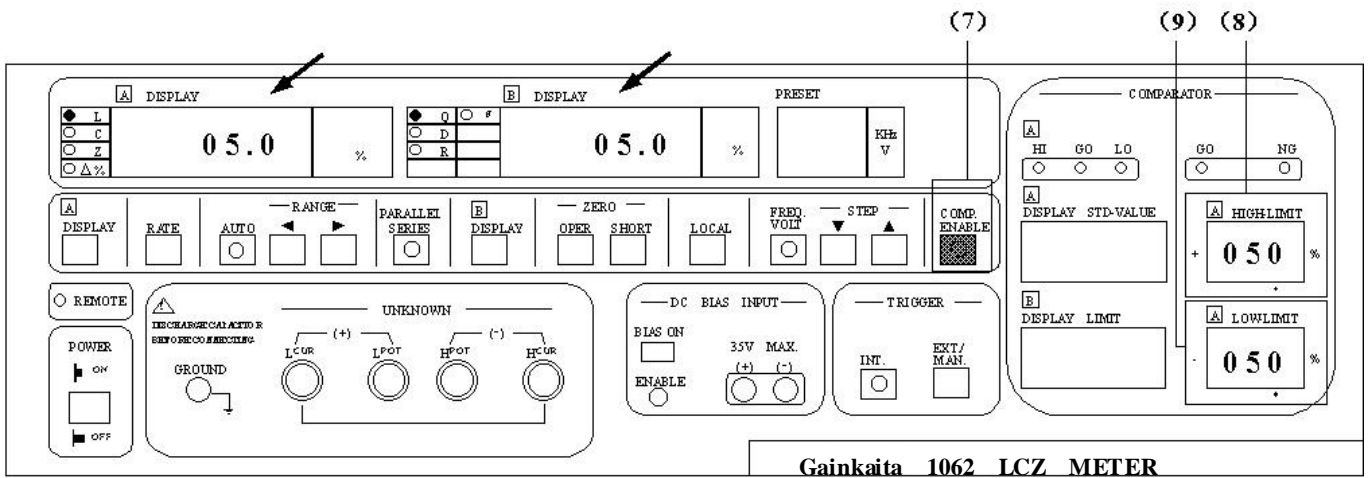

(10). 再按一次 ENALBE/COMP.键, 比较器正式启用, 接上待测试物即可执行判别.

注: 比较器作用时, 所有设定条件除 RATE 键可改变测试速度,

A DISPLAY 键可选择 $\Delta\%$ 或测试值, TERIGGER 方式可变外, 其余功能键无用.

● 标准品输入法: 以 $100\mu\text{H} \pm 5\%$ Q 值 6 以上为例

(1). 将标准品接在测试端以 AUTO RANGE 方式测试(亦可以固定档位测试), 以显示位数之多寡来设定, 假设 **A** DISPLAY 显示 $100.12 \mu\text{H}$, **B** DISPLAY 显示 6.283.

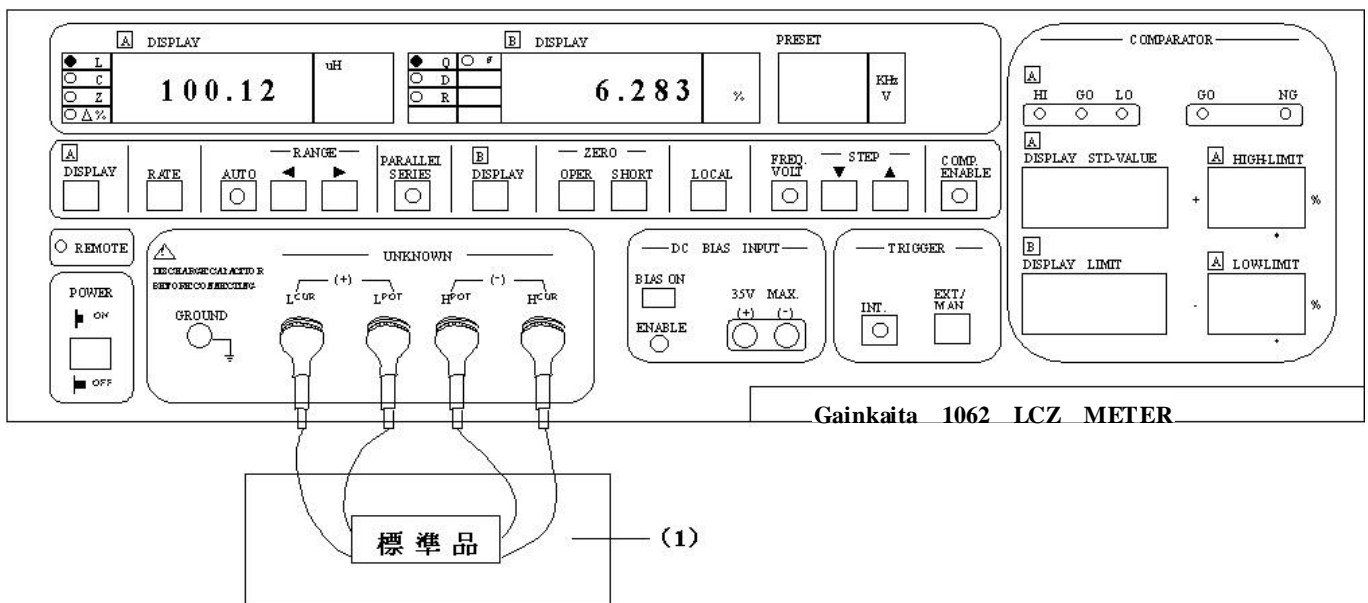

(2). 将 **A** DISPLAY STD-VALUE 指拨开关拨成 10000.

(3). 将 **B** DISPLAY LIMIT 指拨开关拨成 06000.

(4). 将 **A** HIGH-LIMIT 指拨开关拨成 005.0.

(5). 将 **A** LOW-LIMIT 指拨开关拨成 005.0.

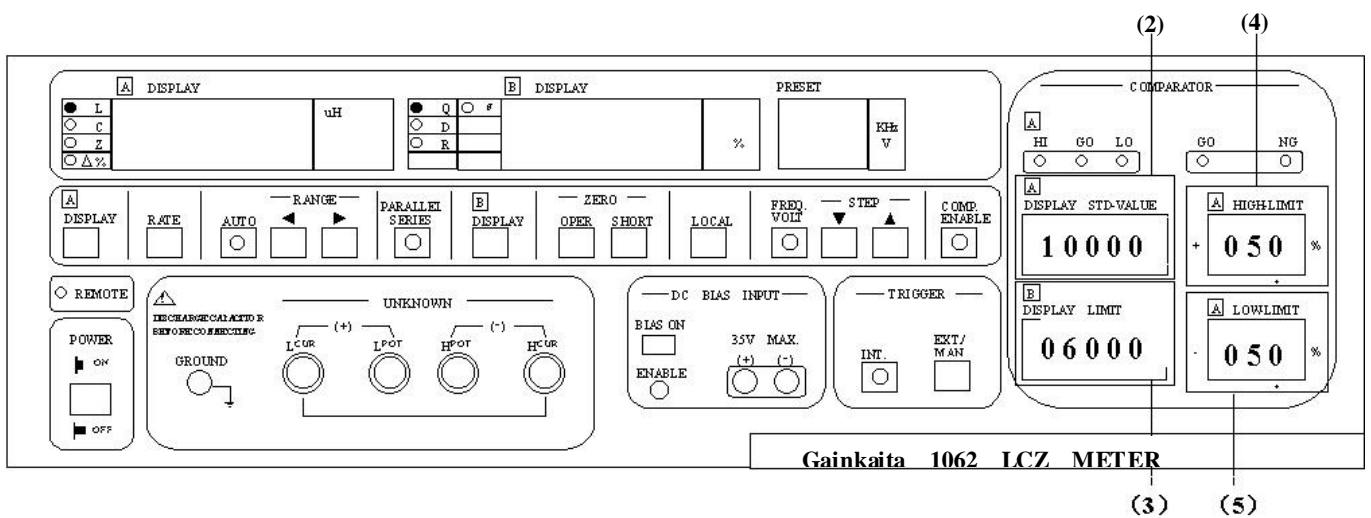

(6). 按 ENABLE/COMP. (第一次) 显示 Std Lmt, **A** DISPLAY 显示标准值: 100.00uH, **B** DISPLAY 显示限定值: 6.000.

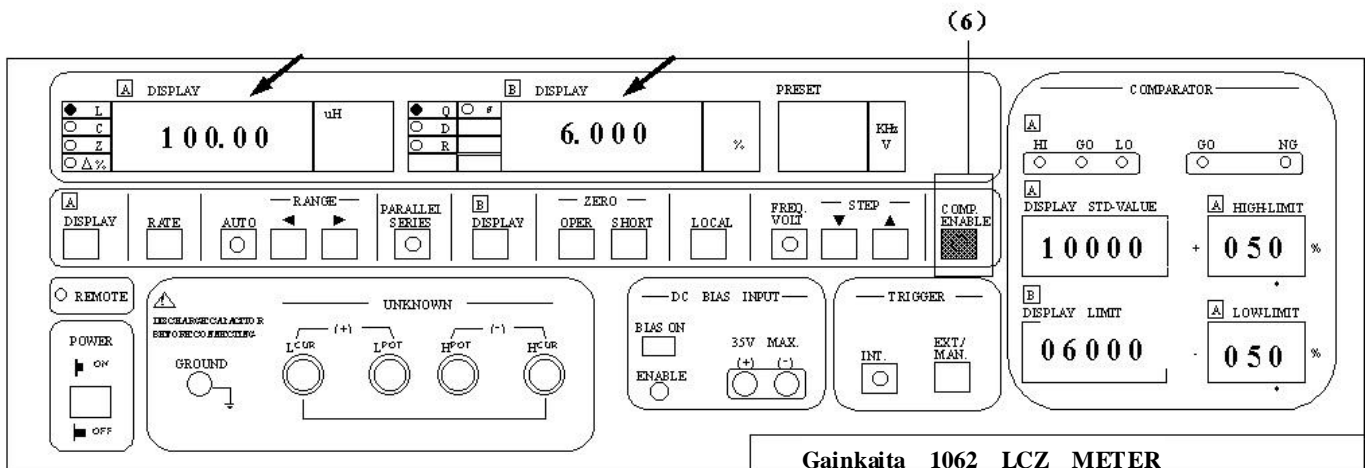

- (7). 按 ENABLE/COMP. 键(第二次) $\xrightarrow{\text{显示}}$ HI-LO, **A** DISPLAY 显示上限百分比: 05.0%, **B** DISPLAY 显示下限百分比 05.0%.

注:(6)(7)步骤可确认设定是否有误,或指拨开关是否正常.

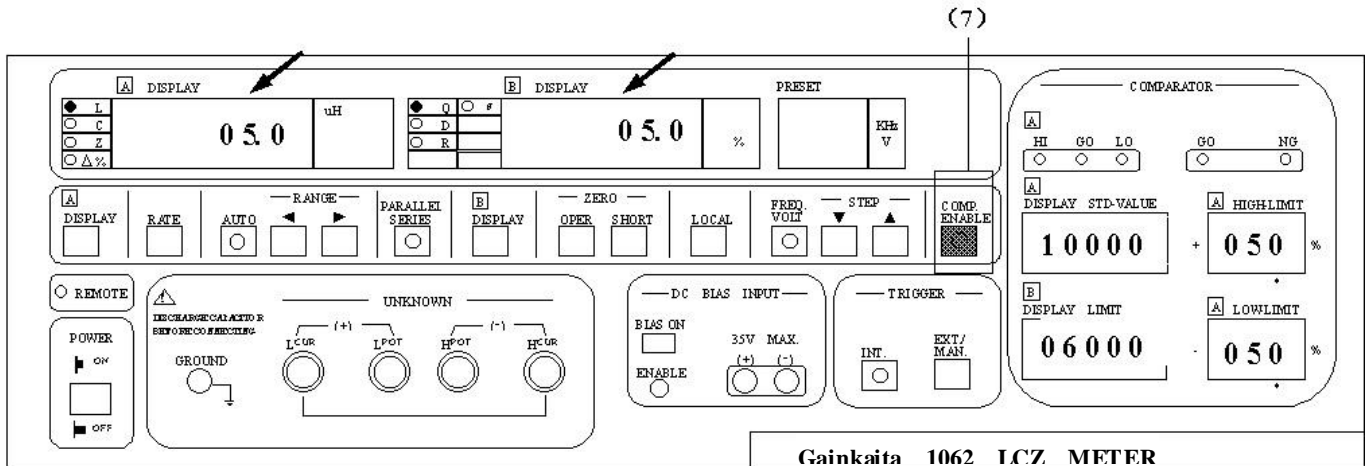

- (8). 再按一次 ENABLE/COMP. 键,比较器即开始作用,接上测试物可执行判别.

注: 此设定方式仍根据接上待测试物时显示之位数来决定指拨之数字.

如上例若 **A** DISPLAY 显示为 100.1 uH 则指拨开关须拨为 01000, 依此类推.

