

J SERIES

10.0x10.0 Washable Tact Switch

TACT SWITCH



HOW TO ORDER

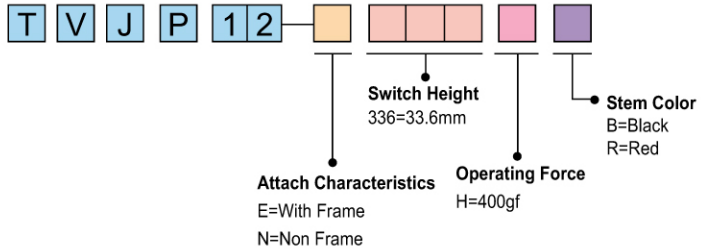

◆ FEATURES

- Waterproof sealed structure
- 10x10mm snap-in type
- Partial output terminal can be used as jumper pin
- 33.6mm long switch height

◆ APPLICATIONS

- Major home appliances
- Distribution boards
- Storage batteries
- Office equipment

◆ SPECIFICATION

Items		Standard	Items		Standard
Operating temperature range		-20°C to +70°C	Durability	Lifetime	B:C=100,000Cycles
Electrical performance	Rating	50mA, 12V DC	Mechanical performance	Operating force	H:400gf ± 70gf
	Insulation resistance	100MΩ min. 100V DC		Travel	0.40 ± 0.2mm
	Dielectric strength	250V AC for 1 min.			
	Contact resistance	100mΩ max.			

◆ WATER RESISTING PERFORMANCE

Items	Model	Vertical type	Horizontal type
Temperature of water		60°C	60°C
Depth of water		10cm	10cm
Immersion duration		240h	1h

◆ DIAGRAM

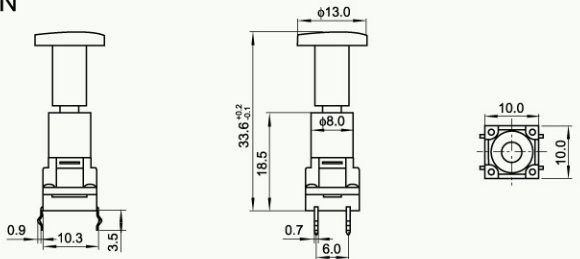
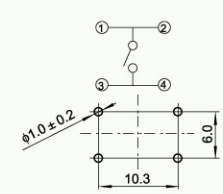
No.	Dimensions	Circuit Diagram PCB Layout
1	<p>● TVJP12-N</p> 	
2	<p>● TVJP12-E</p> 