

嘉尼赫®
JAINNHER®



CENTER HOLE GRINDING MACHINE

中心孔研磨機



005



嘉尼赫®
JAINNHER®

CENTER HOLE GRINDING MACHINE

中心孔研磨機



應用範圍

- 本機專門設計使用於圓筒研磨時，須提高精密幾何的中心孔，例如：切削工具、刀把、主軸、齒輪傳動軸等之中心孔定位研磨。

Applicable

- The machine is suitable for cutting tool, spindle, tool holder, gear shafts and tempered transmission shafts and the workpiece requests high accuracy from cylindrical grinding. The quality of cylindrical grinding will depend on the center hole circular geometrical accuracy.

高精度3D空間同步研磨設計

穩定性佳、高精確度、品質保證

Stability! High Precision and Quality

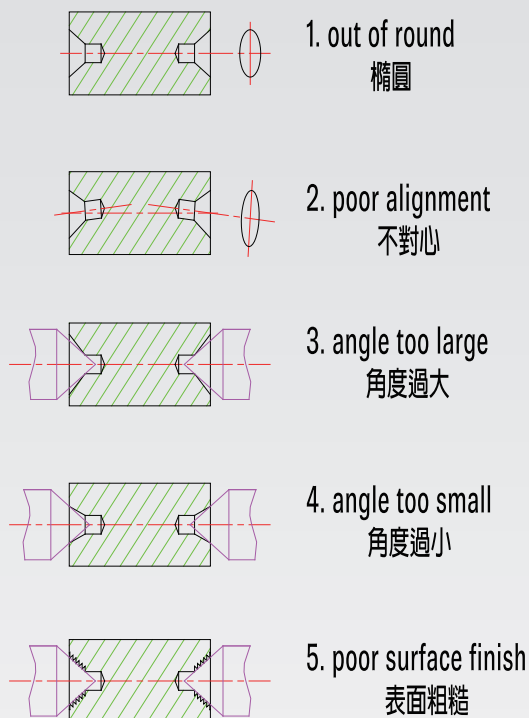

高精度的研磨動作設計

一般中心孔加工常有如左圖所示之各種不良品質發生。本機獨特的高精度3D空間同步研磨設計，確保中心孔的穩定性和心對心的精確度

- 1、砂輪的旋轉運動
- 2、砂輪主軸的行星運動
- 3、砂輪沿錐形表面直線往復運動

Exclusive Design of Grinding Operation

With exclusive 3D design of synchronized grinding motion, the machine will be very stable and automatically locates center.

- Grinding wheel rotation.
- Planetary motion of grinding wheel spindle
- Grinding wheel reciprocating motion will be along on conical surface.

- 基於三軸同步研磨動作，研磨出均質的交錯研磨線路樣式，具有微小的油袋功能，可形成永久性油膜位於工件與圓筒磨床的固定頂心間。如此可防止無油膜與頂心卡死並可消除不必要的誤差來源，以利高品質的圓筒磨床。

- Based on three-axis simultaneous grinding action, grinding out heterogeneous pattern, with a small oil groove feature, oil film can be formed in a permanent between workpiece and center of cylindrical grinding machine. This is to prevent non-film stuck with the center and can eliminate unnecessary error, in order to facilitate high quality cylindrical grinding.

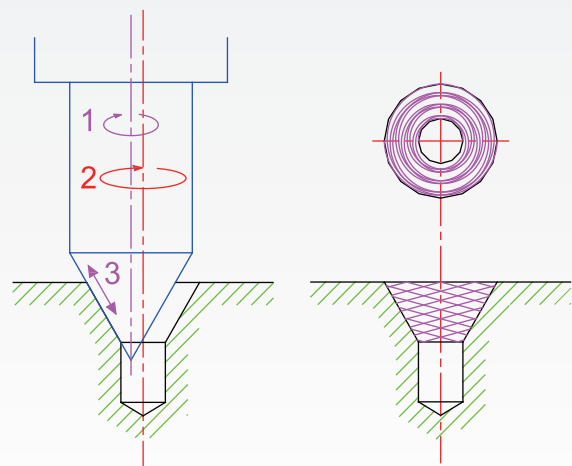

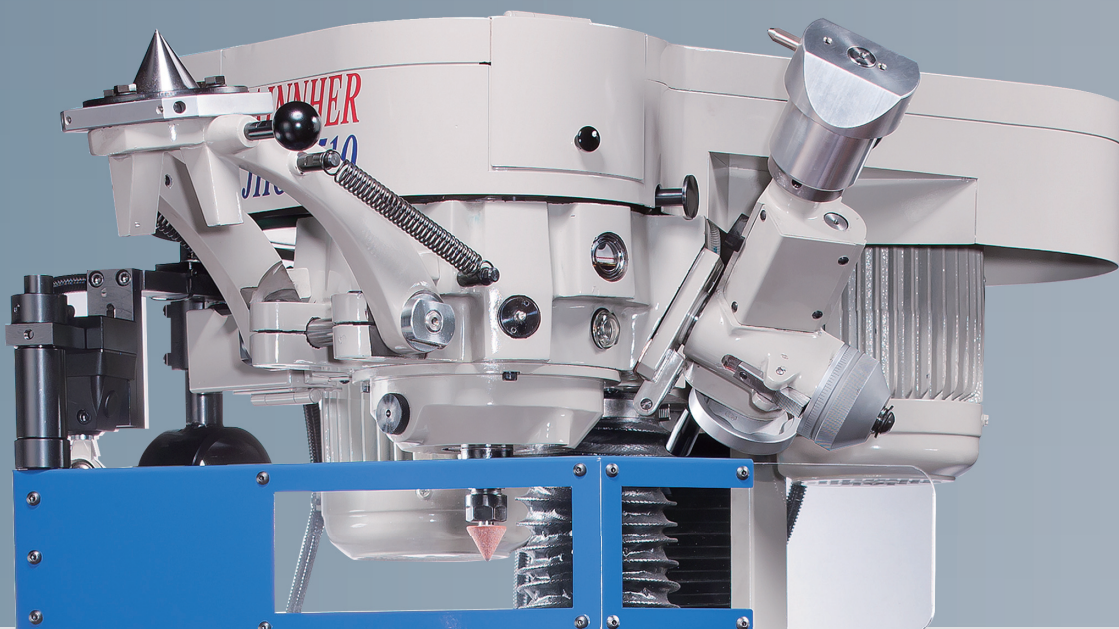

砂輪主軸頭

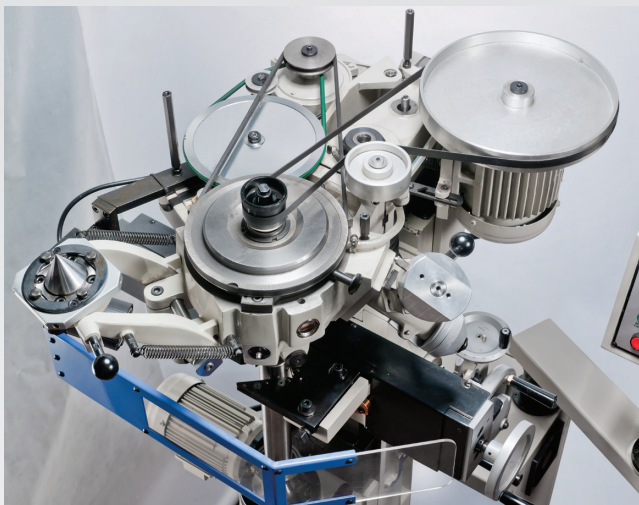

砂輪主軸頭

- 砂輪主軸頭是結合主軸頭、行星運動機構、砂輪主軸、修砂座及主軸運動機構等組合而成。
- 砂輪主軸之旋轉運動係採用1/2HP x 2P馬達傳動，經適壓張力惰輪，帶動砂輪主軸高速運轉，轉速可變頻器變換。
- 行星傳動裝置採用1/5HP x 8P馬達傳動，可同時進行砂輪主軸的行星運動及砂輪沿錐形表面直線往復運動。
- 砂輪主軸採用軸套組設計，容易裝卸，前後端使用4個P4級高速精密斜角滾珠軸承支撐，並使用油霧潤滑，具高轉速及高精度之特性。

Grinding Wheel Spindle Head

- Grinding wheel spindle head is a combination of the spindle head, planetary motion mechanism, wheel spindle, dressing device and spindle motion mechanism.
- Rotating of grinding wheel spindle driven by 1/2HP x 2P motor, through the appropriate pressure tension of idler, driving wheel spindle in high speed rotating. The speed can be changed by frequency converter.
- Planetary transmission device adopt 1/5HP x 8P motor, which can be simultaneously doing wheel spindle planetary motion and reciprocating motion along on conical surface.
- Grinding wheel spindle use sleeve design, easy assembling, with 4 high-speed precision P4 class Angular ball bearings support in front and back and oil mist lubrication, have high speed and precision characteristics.



嘉尼赫®
JAINNHER®

人性化操作介面

設計領先、效能第一

Humanized Operation Interface!

Advanced Design Concepts!

☛ 高精度的研磨動作設計

- 砂輪主軸噴霧式給油裝置霧化器接上 $1\sim 8\text{kg}/\text{cm}^2$ 的壓縮空氣，使油霧產生 $1.5\sim 2\text{kg}/\text{cm}^2$ 的壓力進行潤滑。
- The atomizer device for grinding wheel spindle connect with $1\sim 8\text{kg}/\text{cm}^2$ compressed air, therefore, the oil mist produced $1.5\sim 2\text{kg}/\text{cm}^2$ pressure for lubrication.



☛ 斜錐砂輪修整裝置

- 本裝置置於砂輪主軸頭側，可手動旋入就修砂位置，修砂時只有砂輪主軸自轉，操作中，除了縱向移動外，鑽石修刀可同步進行側向來回的震盪動作，並沿著砂輪錐面直線移動，如此可確保錐度砂輪外型的一致性幾何精度，完全不受鑽石修刀位置與磨耗影響。

☛ Conical type Wheel Dressing Device

- This device placed on the side of grinding wheel head, can be manually rotate into dressing position and while dressing only wheel spindle rotating. During operation, the device moved longitudinal and the diamond dresser moved simultaneous back and forth oscillation of lateral motion, along the wheel cone linear movement. This ensures the consistency geometric accuracy of wheel shape, completely non- effect on dresser position and wearing.



嘉尼赫®
JAINNHER®

CENTER HOLE GRINDING MACHINE 中心孔研磨機

➤ 上擺動頂心與下頂心裝置保持上擺動頂心與下頂心一致性之基準。

Upper Swing center and Lower Center Device
Keep upper swing center and lower center consistency benchmark.

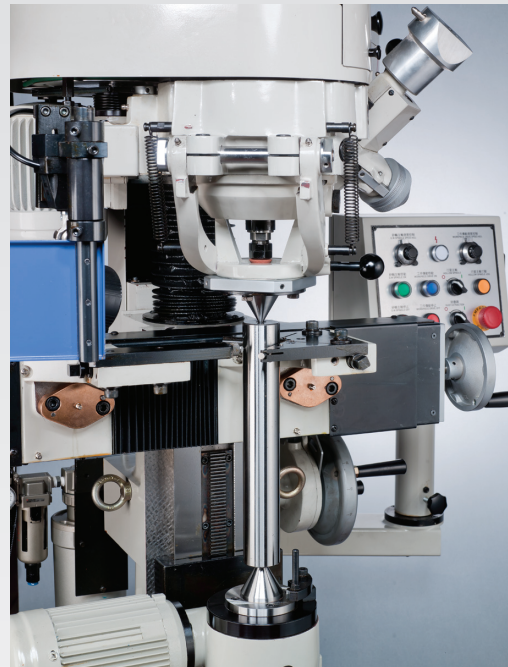

➤ 工件夾持裝置

- 自動對心的夾持裝置簡化工件的設定工作。
(可依據加工需求，提供不同夾持裝置)。

➤ Workpiece Holding Device

- Automatic workpiece clamping simplify the setting job.
(can be based on processing needs and provide different clamping devices)

➤ 工件驅動裝置

- 當中心孔研磨時，工件同時驅動，提高了中心孔與外圓的同心度等級，轉速可變頻器轉換。

➤ Workpiece Driving Device

- While grinding, the workpiece driven simultaneous. It improves the center hole and cylindrical concentric accuracy, the speed can be changed by frequency converter.

標準附件
Standard
Accessories

托架
Supporter



Ø30 鎢鋼長頂針
Ø30 Tungsten Long Center



同心校正棒
Concentric adjusting rod



工具及工具箱
Tool box & Tools

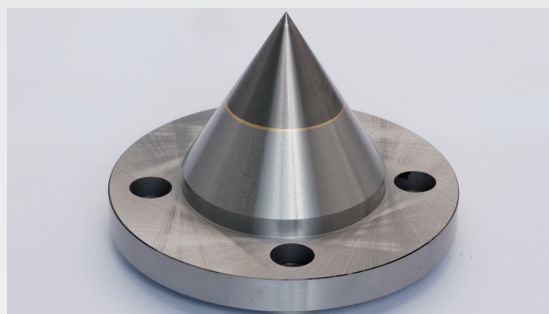

Ø30 鎢鋼短頂針
Ø30 Tungsten Short Center



砂輪
Grinding Wheel

選配附件
Optional Accessories



集塵器
Dust collector

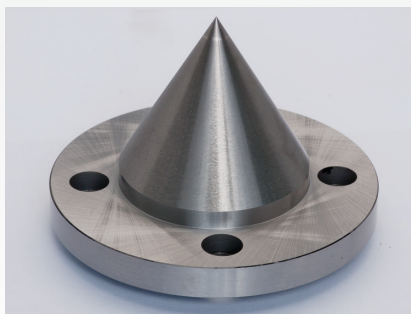

Ø52 全鎢鋼短頂針
Ø52 Tungsten Short Center



Ø52 盤形頂針
Ø52 Center