

MODEL SPECIFIC OPERATIONAL MANUAL



ARCHITECT SERIES



TABLE OF CONTENTS

1. Introduction	3
2. General information	4
2.1 What is a laser and how does it work?	6
2.2 Laser Safety first!	7
2.3 Installation of the System	8
2.4 Control System	9
2.5 Control Options	10
2.6 Connection Diagram	11
2.7 Multiple System Interlock	12
2.8 Switching ON sequence and User Interlock	13
2.9 Maintenance	15
3. Item Checklist	16
4. System Overview	17
4.1 Top View	18
4.2 Side View	19
5. Beam Alignment	20
6. Technical Specifications	21
6.1 Technical Specifications [Architect W400B]	22



INTRODUCTION

Thank you for purchasing this KVANT product.

To ensure proper operation, please read this manual carefully before using the product.
After reading it, keep it in a safe place for future reference.

GENERAL INFORMATION



The following chapters explain important information about lasers in general, basic laser safety and some tips about how to use this device correctly.

Please spend some time reading these information as some of them are critical for safe and efficient operation of this laser display system.



KVANT

This product is in conformity with performance standards for laser products under 21 CFR Part 1010.4 and 1040.11 except with respect to those characteristics authorized by Variance Number: 2012-V-0620 Effective Date: Dec.31 . 2018





Date of Manufacture 03 2021
Month Year

KVANT spol. s.r.o.
 Opavska 24, 831 01 Bratislava 37, Slovakia
 Made in Slovakia

Max current at 110V: 3A
 Max current at 230V: 3A

LASER PROJECTOR

Model: **ARCHITECT W400B**
 Output power: **400 W**
 Laser class: **4**
 Input power: **100-240VAC/ 20-10 A**
 50 Hz 2200VA
 Serial No.: **101226823**

Caution



This Architect laser system is rated as a **Class IV laser product** and manufactured in accordance to **EN 60825-1:2014**. Avoid eye or skin exposure to direct or scattered radiation. Wear protective goggles of suitable optical density if necessary.



If the laser is operated in a situation where health or property injury may occur the operation must be stopped immediately.



The manufacturer and its distributors cannot be held responsible for any damages caused by improper use or misuse of this KVANT laser system. The owner/user is fully responsible for using this product in accordance to laser safety regulations of the country or state where the system is being used.

Please note that some other optical devices such as cameras, camcorders, video projector etc. can be damaged if exposed to excessive laser radiation.

Handling precautions

This laser system is a precision device that contains some sensitive opto-electronics components. DO NOT drop it or subject it to physical shock.

This laser system has waterproof and dust-proof enclosure.

The laser system contains precision electronic circuitry. Never attempt to disassemble the laser yourself.

If the laser is suddenly brought in from the cold into a warm room, condensation may form on the laser and internal parts.

If condensation forms on the laser body, do not use the laser as this may damage the laser system. If there is condensation, wait until it has evaporated before using it.

WHAT IS A LASER AND HOW DOES IT WORK?

What is a LASER?

The laser is a device that creates continuous visible light energy waves (streams of photons that are referred to as “laser radiation”) with the same amplitude and phase that are flowing in the same direction; meaning they are coherent – they stick together and form a laser beam.

The width of a single wave is measured in nano-meters and defines the colour and visibility of the laser beam. The visible spectrum of the human eye is roughly between 400nm and 700nm, going from violet to a dark red colour. A human eye is most sensitive to a green light of around 555nm, meaning that a 1W of green laser will always appear more visible than 1W of any other colour laser. 1W of quality laser light is very powerful and although it doesn't sound like much it can burn eye retinas, skin and clothes or even start a fire!

What makes the laser visible in mid-air?

Mainly it is the particles of dust in the air that the laser beam hits on its path, scattering the light. This dust or fog is called a “scattering medium”. That's why we “laserists” use haze or smoke machines to make lasers more visible. Too much of the haze or smoke will greatly attenuate the visibility, but the right amount will make all the difference between no show and a great show.

When outdoors, lasers mainly reflect off dust and mist in the air but due to unpredictable wind conditions we can never make sure the hazers or smoke machines will be effective enough. And that's why we use high power lasers for outdoor shows – to substitute for the lack of dust, haze and smoke.

Colours

Standard full colour analogue lasers use three primary colours: Red, Green and Blue. By mixing those together you can pretty much get any secondary colour:

Red + Blue = Magenta
Red + Green = Yellow
Green + Blue = Cyan
Red + Green + Blue = White

Of course the number and precision of the colours is determined by the modulation, stability and linearity of the system. If the system is not stable enough, it will produce different colours every time it is used, making it virtually impossible to match the colours of two systems at any one time. This is very often the case with systems from far east manufacturers and with re-branded lasers that are being presented as European makes.

How far does it travel?

Technically, the laser light will travel forever until it strikes a surface and is absorbed. A better question is – how far will the light travel and still be useful? Depending on the power output of the system and weather conditions, the laser can be visible for miles – that is why we need to be cautious about aircrafts when performing outdoor shows. And if you get a system that is powerful enough then yes, it can reach the Moon.

Scanning System

A scanning system is essentially two tiny mirrors, each moving on X or Y axis. By working together they can “scan” the laser beam over a wide angle in front of the projector. The scanning system can not only direct the laser beam to specific, static locations, but it can also create shapes by rapidly moving the laser beam over a path. Once a shape is scanned more than 20 times per second, it appears static to the human eye. So any shape drawn by a laser is actually produced by one single laser beam being moved by these mirrors very quickly. Every scanning system has a mechanical limit of how fast it can move its mirrors and therefore how many points it can display at any one second and that is usually represented in Points Per Second at a certain scanning angle, i.e. 8 degrees.

LASER SAFETY FIRST!



Before proceeding any further, please read the following safety page very carefully. It could help you avoid dangerous and hazardous situations which could lead to serious injury or property damage.



Any laser system classified as a Class 4 laser must be used with caution. If you are an inexperienced laser operator, we strongly recommend that you attend a laser display safety course before you use this laser system in public areas. There are various places in Europe where you can attend quality training and even a one day course will give you a good amount of valuable information to safely start with.

Unless you are very competent with the use of lasers and about the laser safety, make sure you at least follow these basic laser safety rules:

1. Never look directly into a laser beam.
2. Never look directly into laser aperture if the laser system is switched on.
3. Be aware that lasers can burn the eye retina, skin or cause fires if not used correctly.
4. Audience Scanning is a technique that involves projecting laser effects directly into an audience. Never perform Audience Scanning unless you: a) are trained to do Audience Scanning; b) use a projector that has the proper safety systems built in (such as PASS); and c) have verified that the projected light levels do not exceed the applicable MPE for the jurisdiction. Otherwise, always project with the laser above audience head level – at least 3m above floor level.
5. When projecting the laser outdoors, avoid pointing the laser at aircrafts, buses, trains, etc. Never leave the laser system unattended when it 's switched on.
6. Always check for reflective surfaces within the laser range – these can be very dangerous (i.e. mirror behind the bar in a club could bounce the beam into bar attendant's eye).
7. Never hesitate to use the Emergency STOP if you think there's a fault within the laser system or a potential danger to a person/object caused by the laser performance.

INSTALLATION OF THE SYSTEM

Please follow these rules during the installation:

1. Do not connect the device to power supply during the installation. Only connect the device to power after the installation and mounting have been completed.
2. Mount the system only to mounting point that is strong, secure and away from places where nonauthorised person could get an access to.
3. Always make sure the system is properly tightened down, and that it cannot get loose and move as a result of sound vibrations, cables pulled on, or similar external disturbances.
4. Always attach a safety chain or cable between the projector and its structure (such as truss).
5. Ensure that all the cables have enough length just incase they get caught.
6. Ensure that the system is placed at least 20cm away from walls or any other objects including drapes etc.
7. Ensure that the system is placed well away from any heat sources including spotlights, moving heads, radiators, etc. Make sure there is a sufficient air-flow around the laser system.
8. It is essential that the fan openings are never covered during the laser operation.
9. Always follow the Laser Safety Regulations of respective country where the laser is being used.



The manufacturer is not liable for damages or a injury caused by improper installation of the system. The installation should be carried by a qualified installer who should follow the Laser Safety Regulations of respective country.

2.4 CONTROL SYSTEM

The overall performance of any KVANT laser system is also dependent on the control system that you use for operating the laser as well as the correct device configuration in the laser control software.

Please make sure all the laser settings in your control system are set correctly before you start using your Kvant laser display system.

25 CONTROL OPTIONS

Analog control option = Architect remote control

Kvant Architect laser system with analog control option is dedicated to display static beams with locally adjustable brightness for each R, G, or B colour. Architect Remote Controller with adjusters for each color is supplied with each fixture.

The Architect Remote Controller is equipped with switches for manually operating Shutter control and also for choosing the control type between the Architect remote control or the DMX input, if connected to the fixture.

Manufacturer can supply fixture with analog signal inputs for each colour. Control voltage is within range 0 to +5V DC can be applied to each colour input.



DMX 512 control option

Kvant Architect laser system with DMX 512 control option is dedicated to display static beams with remotely adjustable dynamic brightness for each of R, G or B colour.

DMX control option can be used without the Architect Remote Control device. When the Architect Remote Control is plugged in to the fixture it is necessary to choose the DMX mode with the switch on it.

DMX controller is not included with the fixture. The fixture uses 4 DMX channels - one for each colour R,G,B and 4th channel is dedicated for operating Shutter control!

Each colour output has 255 values to set the corresponding colour brightness. The 4th channel is using "0" and "255" value to operate the shutter. The user can control the brightness of each basic colour by setting the corresponding DMX channel from channel "1" to "3". Desired outputting colour and overall brightness of the output beam can be adjusted by various combinations of each of these three DMX channels. DMX address switch is located inside the fixture and it is accessible through opening the top cover.

You can connect the DMX signal to the fixture through the DMX signal input connector, located on the back side of the fixture.

E-STOP Safety remote



Safety Key

CONNECTION DIAGRAM

Please check that all the control and power leads and interlock door circuitry are correctly connected. Please see following connection diagram.

Power input:

Use supplied NAC3FX power cable to connect the laser system to mains power supply using the INPUT connector.
 Input power: 100-240VAC/20-10A
 50Hz 2200VA

Remote:

For the external analog modulation use the Architect Remote Control, which is supplied with the laser system and can be connected to SF1210 connector. Control voltage is within range 0 to +5V DC and can be applied to each colour input.

DMX:

For the DMX512 control use the 5-Pin XLR connector which is standard for this communication. DMX controller is not included with the fixture.

Safety remote:

Connect the E-STOP Remote device supplied with the laser system or use this safety interlock input to connect your own safety device. The interlock and the safety key are connected in series. The interlock input must be shorted to enable laser emission.



E-STOP Remote safety key must be inserted and switched to ON position in order to disable the interlock.



Shutter key must be inserted and switched to ON position in order to enable laser emission.



Door interlock switch circuitry must be inserted in the E-STOP Remote interlock connector as well in order to disable the interlock.

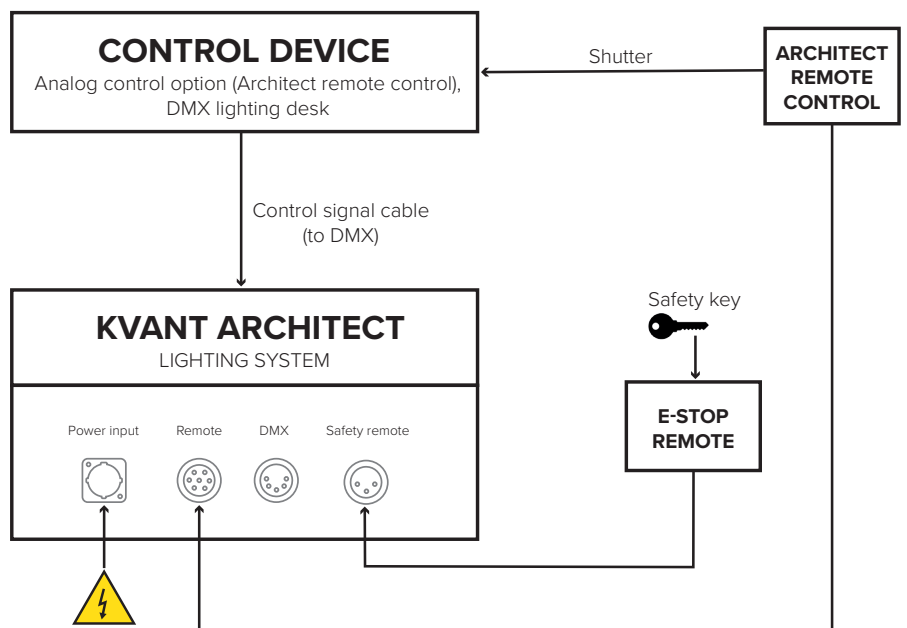

MULTIPLE SYSTEM INTERLOCK

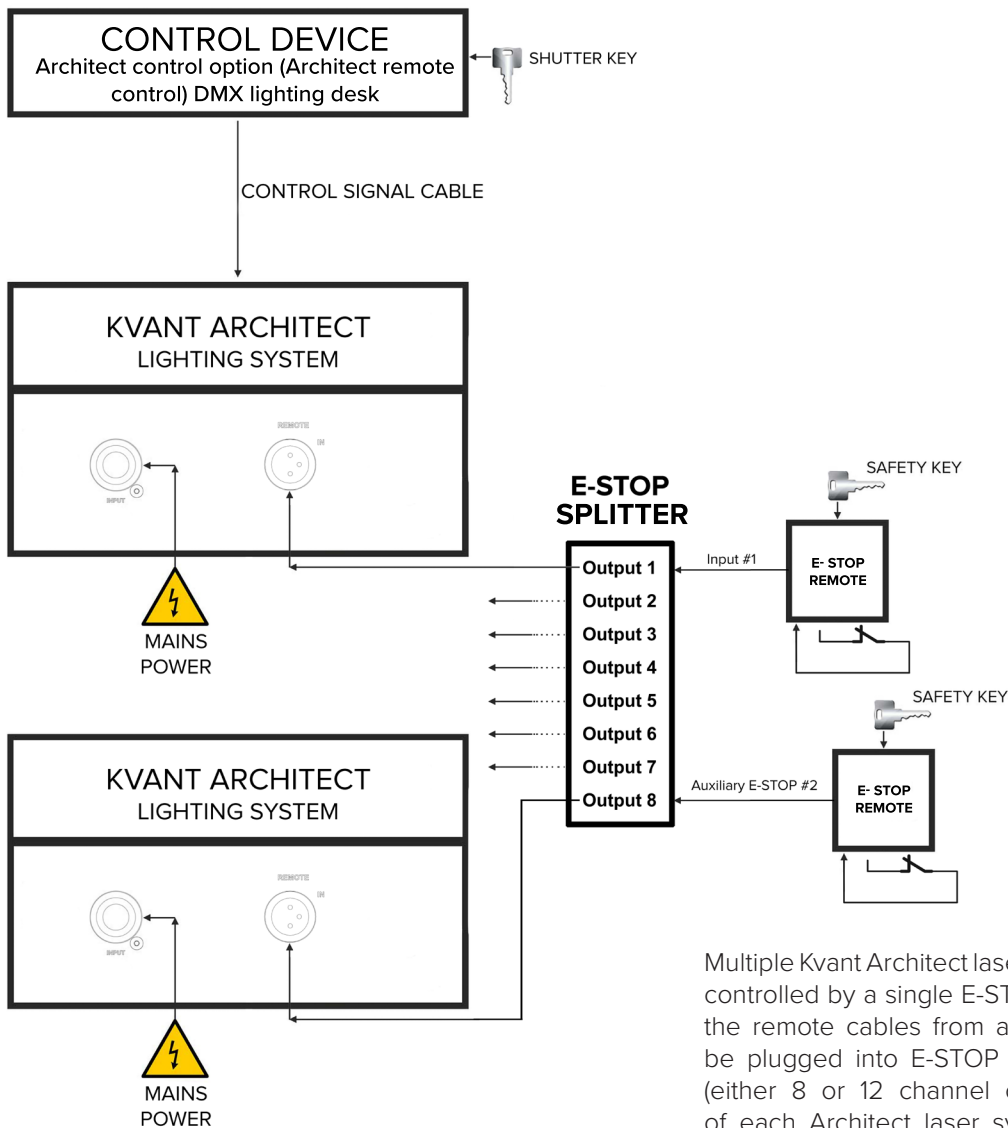

Multiple Kvant Architect laser systems may be operated and controlled by a single E-STOP Remote. In order to do this, the remote cables from all Architect laser systems must be plugged into E-STOP outputs of the E-STOP splitter (either 8 or 12 channel output version). Remote cable of each Architect laser system should be plugged into individual output of E-STOP splitter. This device ensures proper functionality and distribution of E-STOP commands from the E-STOP Remote to each plugged Architect laser system and they are fully compatible with all Kvant laser systems using E-STOP Remote standard. The E-STOP splitter has two inputs, thus two E-STOP Remotes can be used and you can control the Architect laser systems from two different locations. The START buttons of all plugged E-STOP Remotes must be pressed by the operator to disable the interlock and enable the emission. After an Emission Delay period the laser projectors will be ready for use. The E-STOP splitter is not included with the supply and needs to be ordered separately.

SWITCHING ON SEQUENCE AND USER INTERLOCK



Please make sure that all laser display safety requirements are fulfilled in accordance with laws of the country where this KVANT laser system is being used before switching the system ON.

1. Connect the system as showed on Connection Diagram.
2. Turn E-STOP Remote and safety key to ON position.
3. Turn Shutter key to ON position or 4th DMX channel at 255 value.
4. Release the E-STOP button by pulling it upwards.
5. Press the START button on the E-STOP Remote.
6. After an Emission Delay Period the Architect laser system will be ready for use.

Interlock Enabled, Laser Output Terminated

The laser emission of running Architect laser system will be terminated if any of the following events happen:

1. Power loss lasting greater than 2 seconds.
2. Mushroom emergency switch depressed.
3. Safety key Switch on E-STOP Remote turned to OFF position.
4. Shutter switch turned to OFF position or DMX channel 4 changed to 0 value.
5. E-STOP Remote disconnected from KVANT Architect laser system.
6. Door interlock circuitry connected to the E-STOP Remote interlock connector is open. Door interlock may be replaced by the user's own interlock system using a switch or dry relay closure to connect pins 1 and 2 of the E-STOP Remote interlock connector. With pins 1 and 2 shorted, Laser Emission is possible, while all other interlock conditions are in active state. With pins 1 and 2 open, NO Laser Emission is possible. Refer to Connection Drawing below.
7. Cover interlock is opened by removing the top cover.

Restarting Laser After Interlock or Power Failure Event

After the event has been corrected the START button on the E-STOP Remote must be pressed by the operator to disable the Interlock and after an Emission Delay period the laser projector will be ready for use.

Interlock Connection Diagram

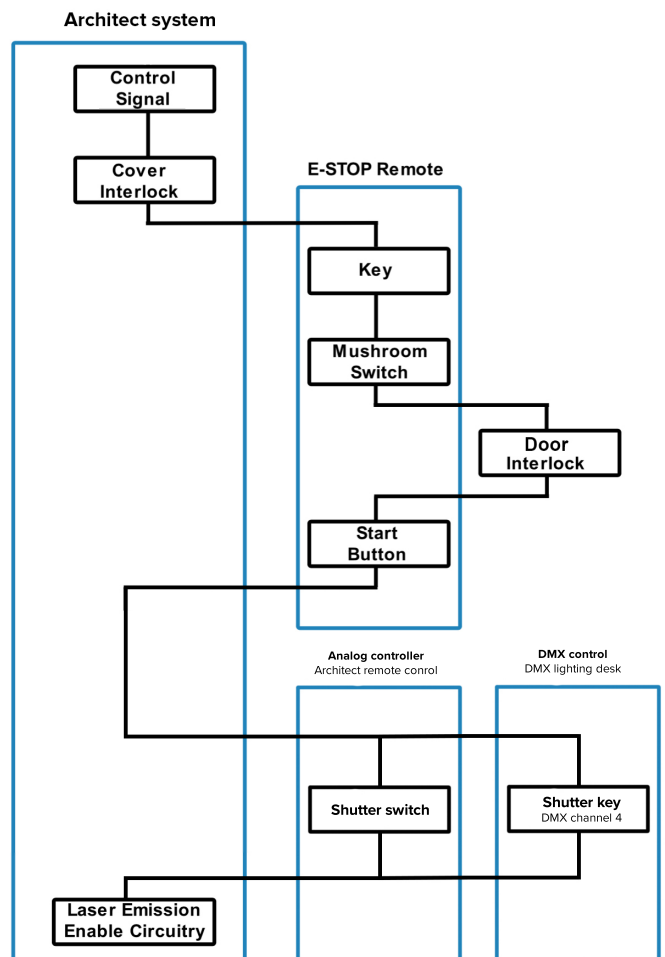

E-STOP Connection Drawing including User Interlock option

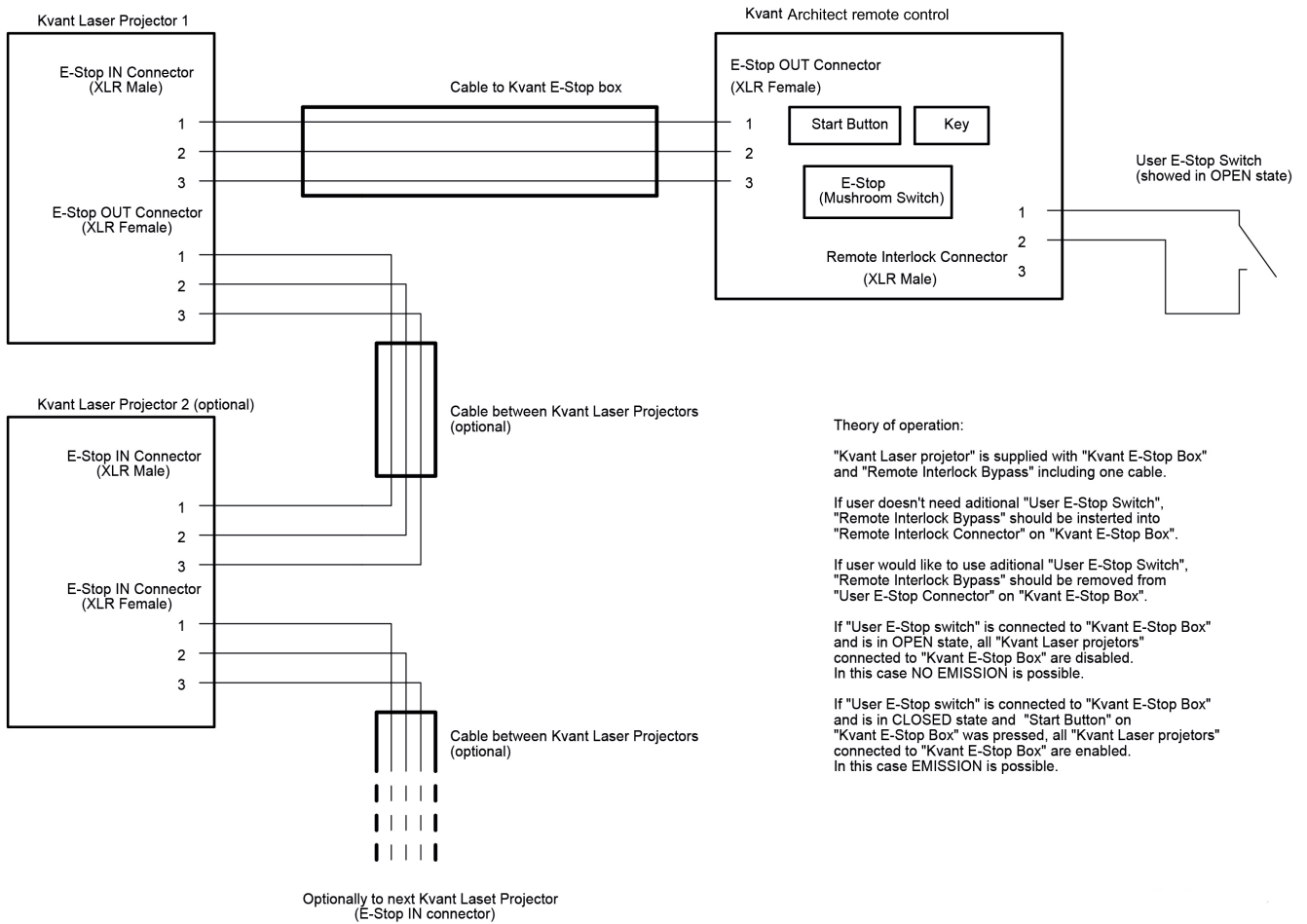

The E-STOP Remote is an integral part of the laser projector. It is there for the safety of the public as well as the operator. Modifying or using anything other than the E-STOP Remote provided, in the manner it was intended, may invalidate your KVANT laser system's variance.

MAINTENANCE

Maintenance: no user serviceable parts inside.

Please note that a laser light entering the aperture of your laser projector (reflected or from another laser) or wrongly reflected beams inside the projector can permanently damage the laser sources.

The manufacturer's warranty does not cover such damage.



Although KVANT uses the latest technology to protect all the critical components inside this laser system against Electrostatic Discharge, the semiconductor laser diodes within this system are extremely vulnerable to it. This is due to some of the electronic components being exposed when the top cover is taken off.

If you decide to proceed with the cleaning of the aperture output window or internal Optics cleaning process yourself, it is absolutely essential that all the common ESD protection rules are strictly followed. We don't accept any responsibility for Electrostatic Discharge damages to laser diodes caused by customer.

Internal Optics

The cleaning of the internal optical components should be performed by an authorised technician only. Incorrect techniques or wrong choice of chemicals used for cleaning could cause serious damage to the laser system. Due to the fact that the optical compartment is split and sealed from the rest of the laser system it shouldn't be necessary to perform this procedure more often than once a year.

External cooler

Use compressed air for cleaning the cooling fans of external cooler. Please always ensure that they are spinning freely. You should perform this service every 2 months if the laser is used regularly or even more often if it is used in dusty conditions.

Cooling fluid level

Due to the water cooled version it is necessary to regularly check the cooling fluid level indicator at the cooling fluid chiller. In case of noticing fluid level out of min-to-max range please contact [Kvant technical support](#) before further steps. Always add certified cooling fluid only! Using not certified fluids immediately voids warranty and can cause corrosion and/or damage of the cooling system.

Drying agent cartridge

Drying agent cartridge (silica gel desiccant) helps to prevent water condensation inside the optical compartment of the Architect laser system, which is much needed in high temperatures and high humidity environments. The desiccant cartridge is installed on the inside of the optical compartment cover.



It is essential to regularly inspect the condition of the silica gel granules inside the cartridges. That can be done through the opening in the middle of the cartridge. If the colour of the granules inside the cartridge is green, instead of brown (brown is when they are dry), it means they are soaked, and they must be dried out. Inspect the cartridge every time you open the optical compartment, or at least once a month.

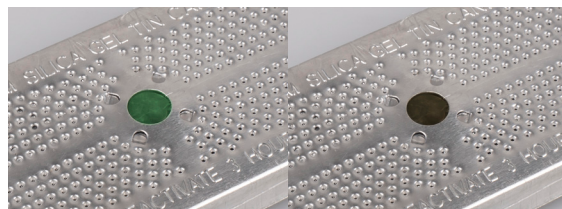

wet silica gel

dry silica gel

The drying out process silica gel is pretty simple:

1. Detach the cartridge from the cover and place it into the conventional oven - do not use microwave!!!
2. Heat the oven to 120°C (250°F) and leave the cartridge inside for about 2-3 hours, until all the moisture is released.
3. Insert the cartridge back into its place and close the optical compartment cover as soon as the cartridge cools down. That way, it will absorb the maximum amount of moisture from the inside of the optical section.



If the granules don't turn brown during this process, they must be replaced with new ones.







Disposal of the equipment

The equipment is made of components and materials such as metal, plastic, aluminium, which can be dismantled, sorted and recycled in accordance with the Waste Act at the end of the life of the equipment or when it is no longer functional.

The equipment can also be handed over as a whole in a collection yard.

ITEM CHECKLIST

Before starting, check that all the following items have been included with your laser system. If anything is missing, contact your supplier.

Item	Number of units	Descriptions
	1x	KVANT Architect Laser System
	1x	Emergency STOP remote and Remote Controller US version BUS ID: 1647 EU version BUS ID: 1648
	1x	Remote Interlock Bypass (for USA only) BUS ID: 651
	2x	Safety and Shutter Keys
	1x	User manual USB drive BUS ID: 1054
	1x	Heavy duty flight case



SYSTEM OVERVIEW

KVANT Architect is a full colour, semiconductor diode laser system designed for professional laser illumination purposes and static visual beam effects.

When operated correctly and in the right conditions the Kvant Architect laser system is able to deliver astonishing visual effects in both outdoor and indoor installations and venues. The Architect laser system can create beam with virtually any colour within the basic RGB palette, secondary mixed colours and white.

The system is fluid cooled and designed with no airflow going through the optical compartment of the system. This ensures that all important optical parts of the system stay clean for longer, keeping the maintenance time down to a minimum. This is a real advantage for permanent outdoor installations and all options of use where dust, smoke or haze are present on a daily basis.

This laser is IP rated up to IP67 (depending on model). It is however important to understand that this system must not be exposed to extreme temperatures, aggressive environment or excessive amounts of dust.

TOP VIEW

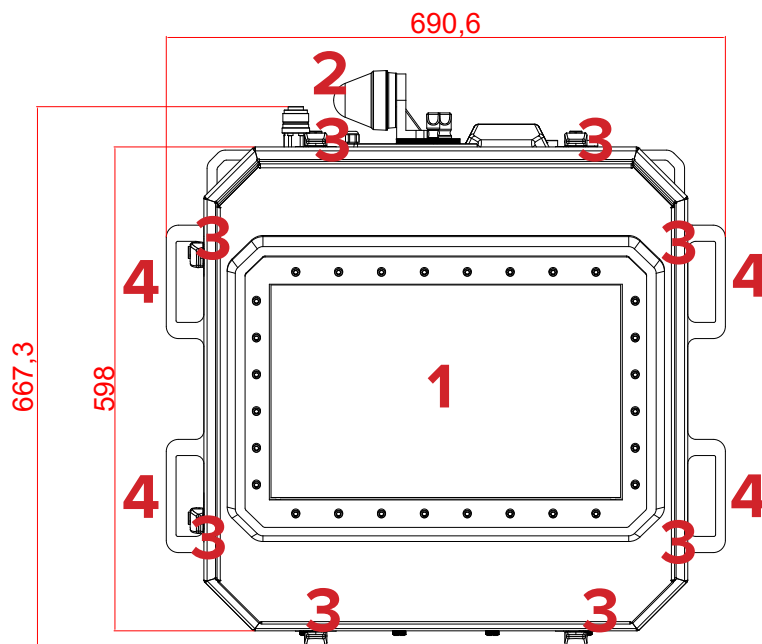

1. Laser aperture.

2. Laser emission indicator.

When this indicator is lit up the laser system can emit the laser radiation.

3. 8pcs top cover fast access fasteners.

To access the optical compartment of the laser system pull up the fasteners and release the clamps from hooks and carefully remove the top cover.

4. 4pcs transportation handles.

BACK VIEW

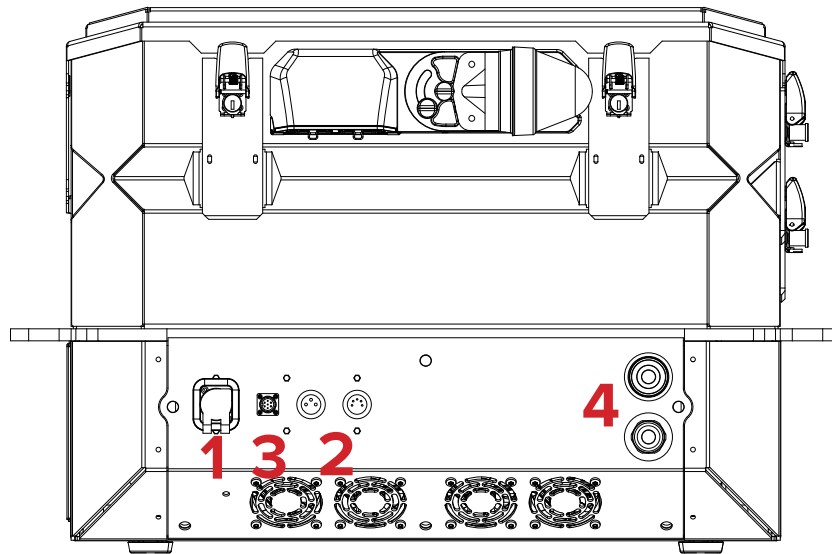

1. Mains power input cable.

2. E-STOP Remote input cable.

In order to use the laser system, the Interlock must be closed circuit. This is done by connecting the E-STOP Remote input cable to the Emergency STOP Remote. Door interlock switch circuitry must be inserted in the E-STOP Remote interlock connector as well in order to disable the interlock and enable emission.

3. Input signal cable.

Kvant Architect systems use either analog input levels 0-5V or DMX signal to control the output power. This is model specific.

4. Chiller hose connectors.

It is necessary to plug chiller hoses in the connectors for succesfull cooling of the laser projector system.



The E-STOP Remote is an integral part of the laser projector. It is there for the safety of the public as well as the operator. In most countries it is required by law to have a fully working Emergency STOP in place for every laser system used. Modifying or using anything other than the E-STOP Remote provided, in the manner it was intended, may invalidate your laser projector's variance.

5 BEAM ALIGNMENT

It is possible that due to transportation, rigging, moving around or vibrations caused by various elements during a set up or laser performance some of the internal optical parts can move slightly resulting in individual beam misalignment.

The decline angle of misaligned beam cant reach greater values, that can be noticeable with bare eyes.

When the misaligned beams become more obvious and are visible to the human eye, it becomes rather unsettling and requires the use of an authorised expert to perform the beam alignment procedure!



This Architect laser system is rated as a **Class IV laser product** and manufactured in accordance to **EN 60825-1:2014**. Avoid eye or skin exposure to direct or scattered radiation. Wear protective goggles of suitable optical density if necessary.



Be cautious when aligning the beams and wear sufficient laser safety protection to avoid accidental exposure to Class 4 laser radiation.



TECHNICAL SPECIFICATIONS

All the technical specifications are subject to change without prior notice.

TECHNICAL SPECIFICATIONS

[ARCHITECT W400B]

Low divergent, high power, full colour, full diode, static architectural laser source

Total optical power 412 W consist of: 114W red, 188W green, 110W blue

Total luminous flux: 120 400 lm

Water cooled version.

General specifications

	Red	Green	Blue	White
Optical power	114 W	188 W	110 W	412 W
Laser wavelength	637 nm	525 nm	455 nm	-
Laser wavelength tolerance	± 5 nm			
Linear polarization	Yes			
Beam matrix structure	17 beams total: 12 red, 4 green, 1 blue			
Total beam matrix size	220 x 380 mm			
Beam full angle divergence	8x3 mrad	6x3 mrad	4x4 mrad	~5 mrad
Luminous efficiency *	138 lm/W	542 lm/W	33 lm/W	-
Calculated luminous flux *	15 700 lm	101 900 lm	3 600 lm	121 200 lm
Module lifetime	>10 000 h	>20 000 h	>20 000 h	-
NOHD	2.9 km			
Cooling	Water + 15% glycol, 6-10 l/min, 20 degree Celsius			
Cooling hose fitting	CEJN series 567			
Dimming	0 - 100%			
Operating temperature range	5 - 40 °C			
Output power vs temperature	< 5 °C: laser generation blocked 5-10 °C: generation limited to 50% 10-35 °C: generation unlimited 35-40 °C: generation limited to 50% > 40 °C: laser generation blocked			
Storage temperature range	-10 - 80 °C			
IP rating	Light source IP67, electronics IP65, for permanent outdoor installation			
Warranty	2 years or 2 000 hours			
Control signal input	DMX and 3x potentiometer			
Laser power input and consumption	100-240VAC, 50-60Hz, < 2.2 kW			
Dimensions (LxWxH)				
Weight	78 kg			

Chiller model (recommended)	SMC HRR030-A-20
Chiller cooling method	Air-cooling
Coolant capacity	Approx. 4 liters
Coolant type	Water + 15 % Glycol
Chiller ambient temperature/Humidity/Altitude	5 - 40 °C / 30 - 70% / less than 3000 m
Chiller power consumption	<1.6 kW
Chiller dimensions	483x686x399 mm
Chiller weight	46 kg

*according to human photopic eye response