

FRONT VIEW

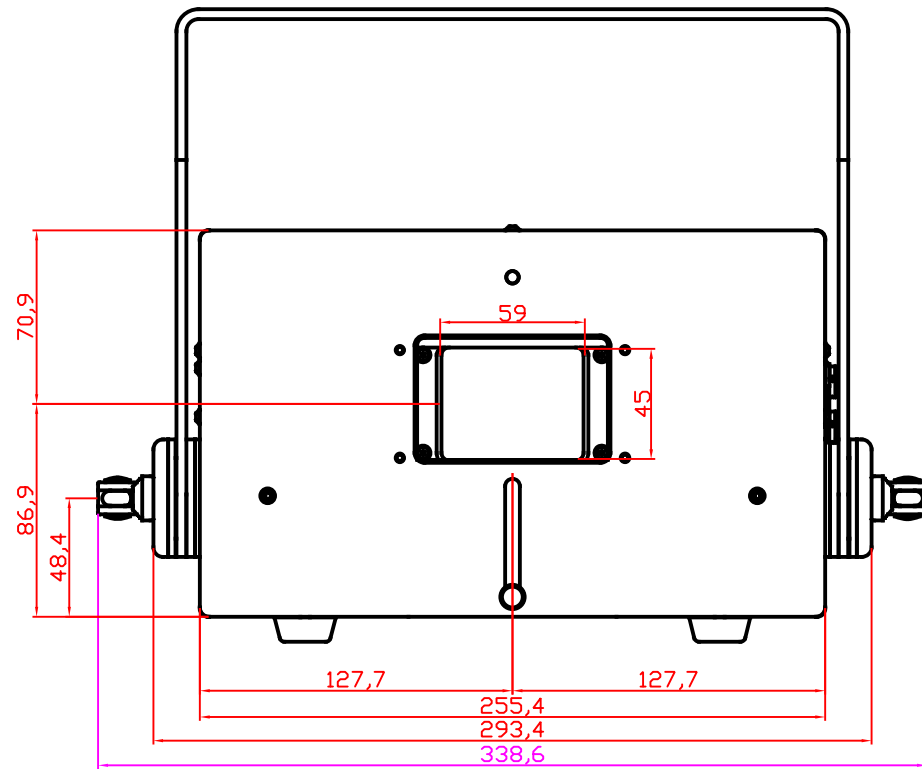

← AIR FLOW

SIDE VIEW

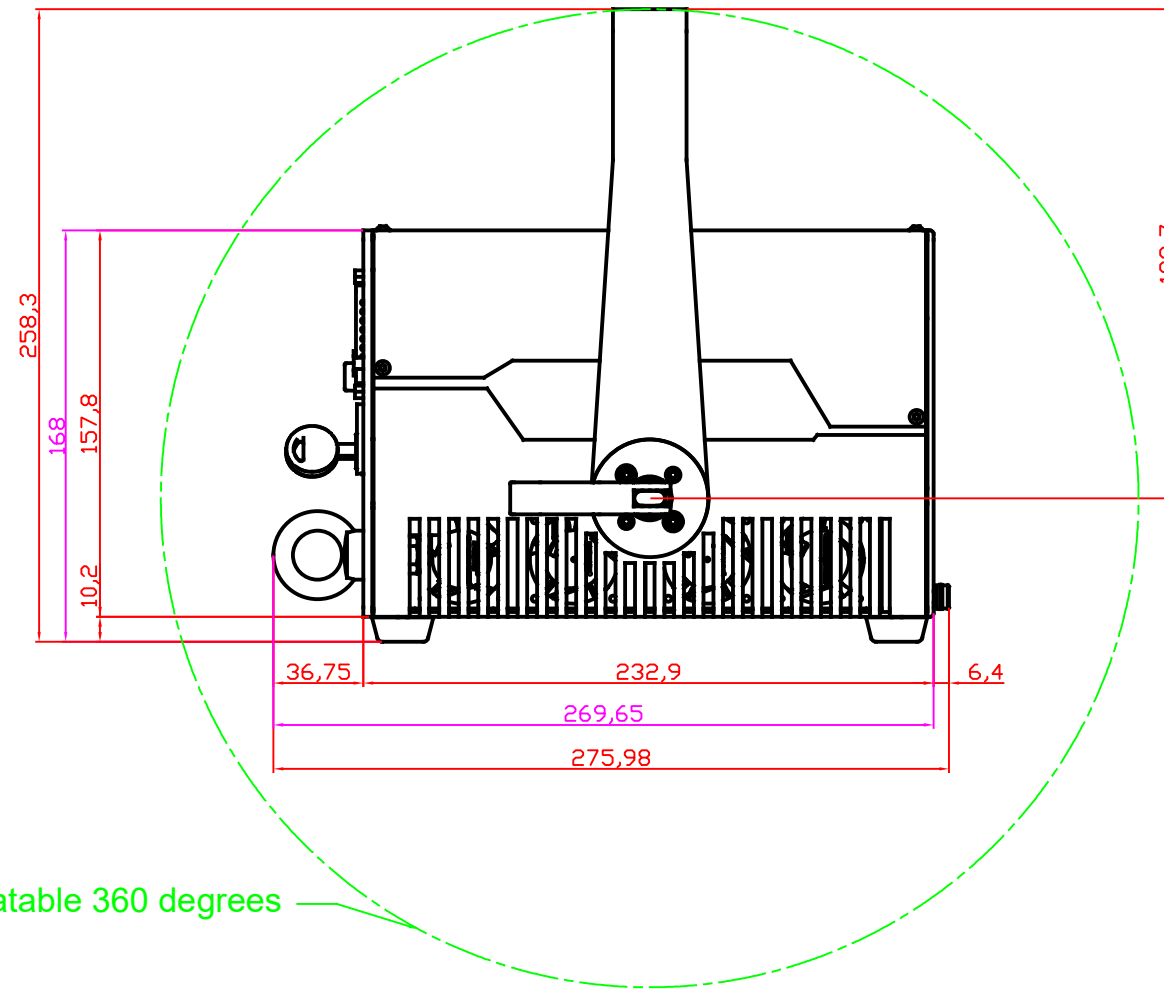

handle fully rotatable 360 degrees

TOP VIEW

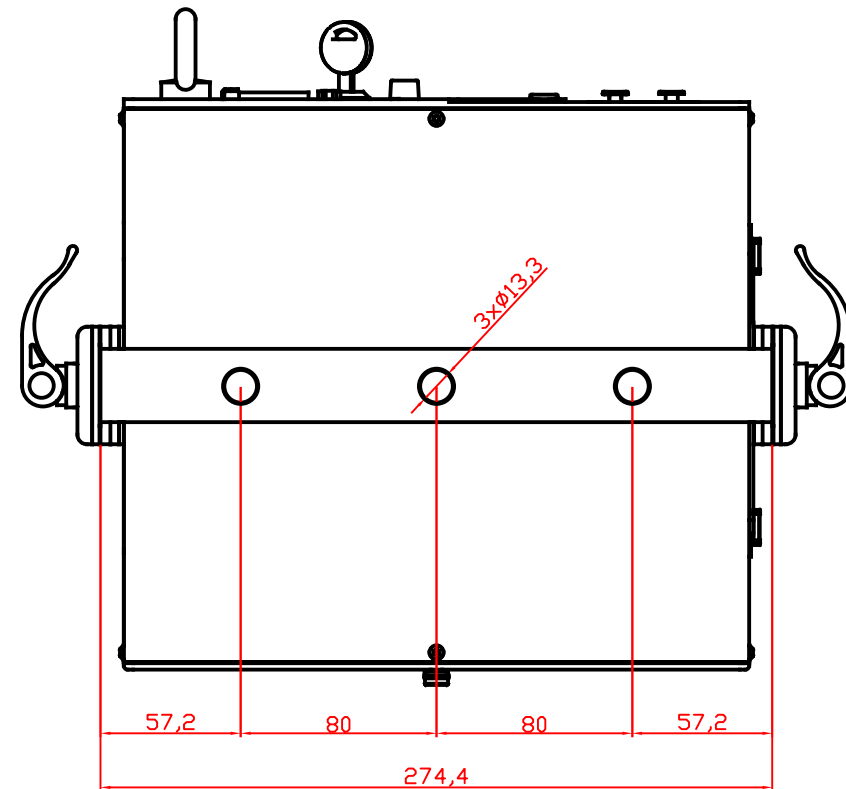

← AIR FLOW

← AIR FLOW

← AIR FLOW

← AIR FLOW

Purple: Overall dimensions, including all the fittings and extrusions; without the 360° swivel bracket

Total airflow needed for the laser projector: 40 cubic metres per hour