

# Smart Twister 迈特短纤倍捻机

# MAGIN

## 苏州英迈杰机械有限公司

Suzhou Imagin Machinery Co.,Ltd.

地址：江苏省苏州工业园区唯文路7号A幢	Add: Block A, No.7 Weiwen Road, Suzhou Industrial Park, Suzhou, Jiangsu, China
电话：0086-512-6706 6492	Tel : 0086-512-6706 6492
传真：0086-512-6706 6493	Fax : 0086-512-6706 6493
网址：www.imaginsz.com	Http: //www.imaginsz.com

- 本样本仅作参考，不作为技术验收依据。
- 为提高产品质量，本公司保留更改规格之权力，恕不另行通知。
- We reserve the right to modify the characteristics of the machines described herein without prior notice.
- The data given in this brochure are not intended as a guarantee.

**苏州英迈杰机械有限公司**  
Suzhou Imagin Machinery Co.,Ltd.

## Machine cross section 机器截面图

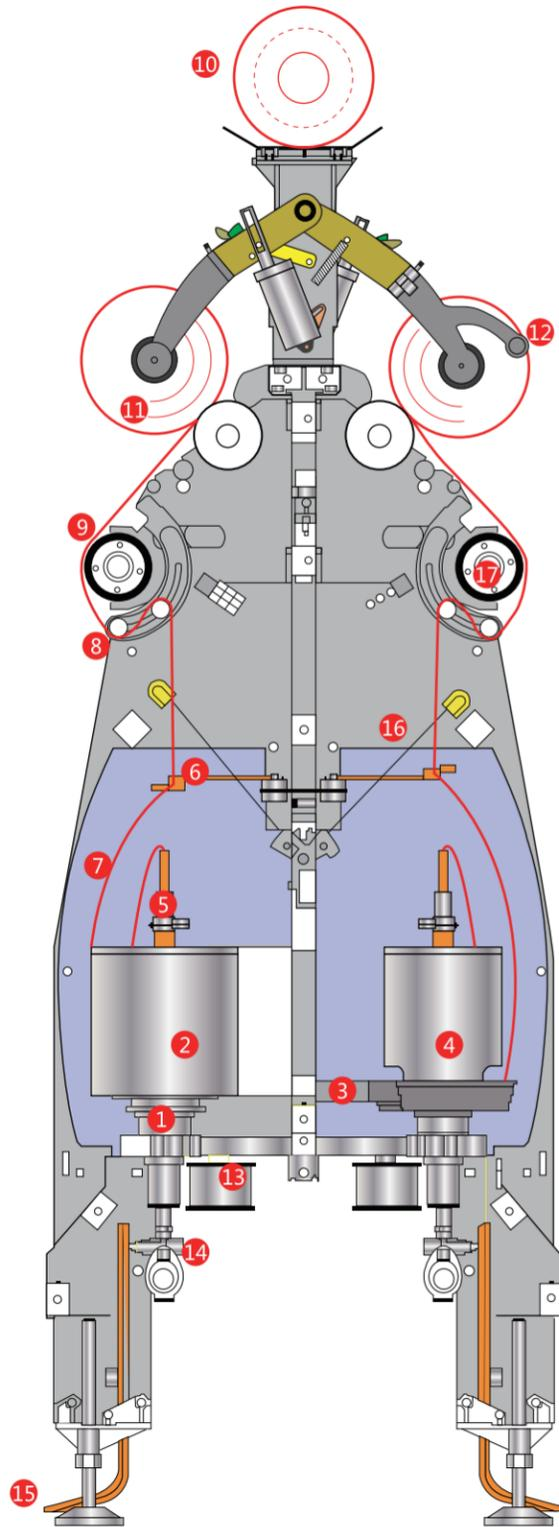

- |   |       |                      |
|---|-------|----------------------|
| ① | 锭子    | Spindle              |
| ② | 气圈罩   | Balloon limiter      |
| ③ | 气圈环   | Balloon Ring         |
| ④ | 锭罐    | Spindle pot          |
| ⑤ | 多级张力器 | Multi-tension device |
| ⑥ | 气圈钩   | Yarn balloon guide   |
| ⑦ | 气圈    | Yarn balloon         |
| ⑧ | 偏转罗拉  | Deflection rollers   |
| ⑨ | 摩擦辊   | Friction roller      |
| ⑩ | 筒纱    | Yarn package         |
| ⑪ | 夹片    | Centering disc       |
| ⑫ | 摇架    | Cradle               |
| ⑬ | 压轮    | Press roller         |
| ⑭ | 穿线阀   | Threading valve      |
| ⑮ | 刹车板   | Foot pedal           |
| ⑯ | 断纱探杆  | Yarn feeler          |
| ⑰ | 超喂罗拉  | Pre-take-up roller   |



## Smart Twister 迈特短纤倍捻机

### 01 Save 节能

- ▲ e-save 锭子序列  
e-save spindle family
- ▲ 新驱动系统  
New driving concept
- ▲ 气圈罩 Balloon limiter

### 02 Maintenance 简易的维护

- ▲ 高可靠性 Reliability
- ▲ 更长的维护周期  
Easy maintenance
- ▲ 装机时间短  
Short installation time

### 03 Automation 自动化

- ▲ 一键完成工艺设定  
Just set all parameters in touch screen
- ▲ 气圈高度集中调节  
Central adjustment for balloon height
- ▲ 超喂包围角集中调节  
Central adjustment for deflection rollers
- ▲ 灵活的筒子成型  
Flexible package formation

### 04 Reinforce 增强

- ▲ 加强型框架，机器更稳定  
Reinforced machine frame
- ▲ 更高的产量 High productivity
- ▲ 更少的占地面积  
Less space requirement

### 05 Technology 高技术

- ▲ 新型的驱动系统  
New driving concept
- ▲ 断电保护功能  
Power failure system

## 传动方式 Transmission

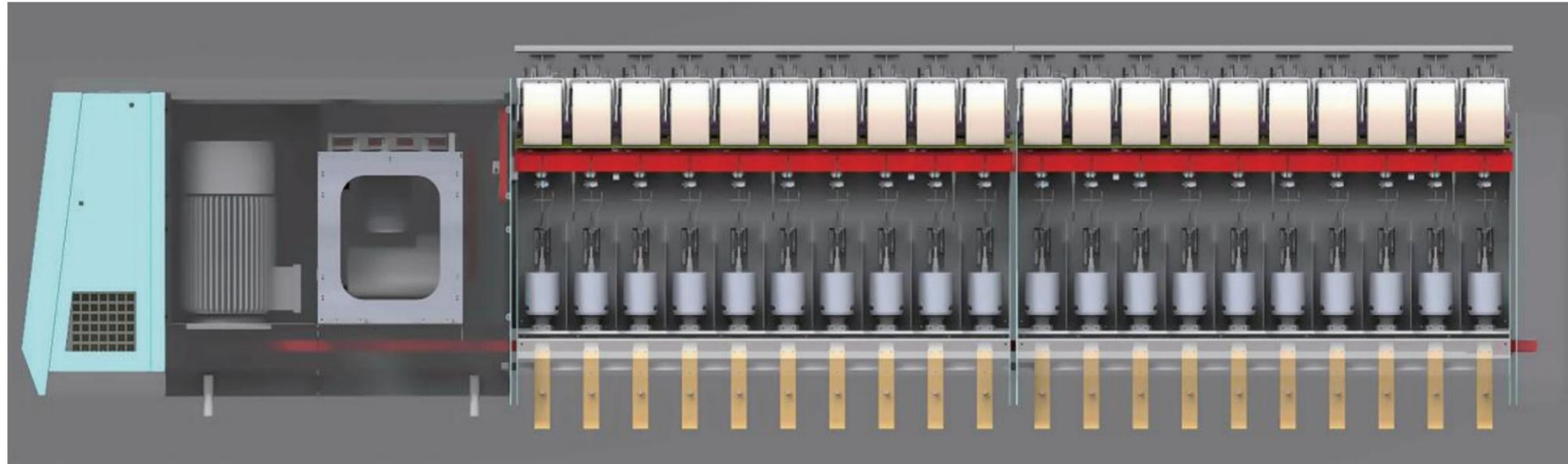

## 伺服驱动 Servo Technology

伺服驱动系统由三个独立的电机组成，分别是：

- ▲主电机：驱动锭子
- ▲小电机：驱动卷取
- ▲伺服电机：驱动横动

The servo drive system uses 3 independent motors to drive respectively:

- ▲main motor: spindles
- ▲slave motor: take-up rollers
- ▲servo motor: traverse

PLC将三个独立的电机以恒定的速比运行，确保在正常运行和启停阶段的捻度一致。

Controlled by PLC, 3 independent motors are running with constant speed ratio (the TPM evenness), both during normal running conditions and start/stop phases.

即使在停电的情况下，(此时主电机充当发电机) PLC也会使三个电机逐步有序减速，直至完全停止。

In case the power supply failure, (the main motor works as generator) PLC will control and reduce their 3 speeds progressively until the complete stop.

## 伺服驱动 Servo Technology

伺服驱动可以实现:

The new electronic servo drives have been designed:

- ▲卷取速度达120米/分钟
- ▲一键设定参数，任意捻度的设定
- ▲电子防叠
- ▲电子松边，用于染色筒子
- ▲无油润滑，免维护
- ▲个性化的筒子成形方式
- ▲Take-up speed is up to 120m/min
- ▲TPM can be set to any level
- ▲Electronically controlled anti-patterning device
- ▲Electronically breathing device for package dyeing
- ▲Oil-free, main tenance-free
- ▲Flexible shape of package

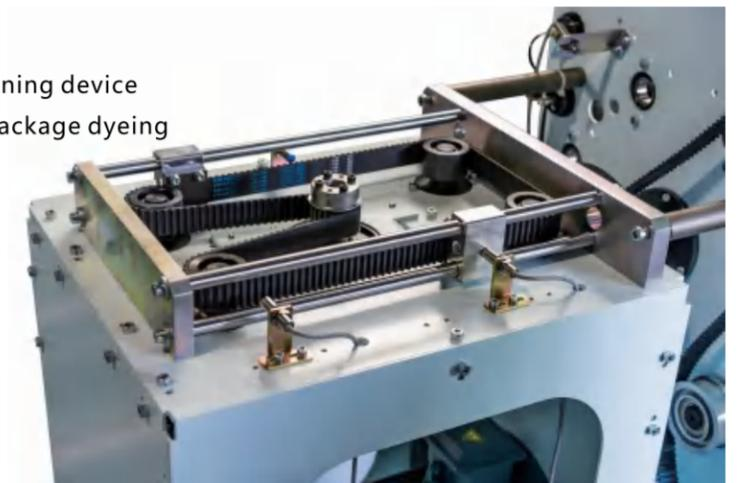

## 倍捻锭子 The spindles

高品质的锭子保证了高品质的纱线

- ▲所有与纱线直接接触的部件均经过特殊表面处理，给纱线以最有效的保护
- ▲震动噪音最小化，锭子中所有的旋转部件均安装在有弹性的构件上
- ▲上部轴承采用自润滑方式并装有特殊的防尘保护
- ▲内部轴承采用单独的油嘴进行油脂润滑以保证更好的润滑效果
- ▲纱线退绕张力调节方便，适应纱线范围广
- ▲气动自清洁纱线通道
- ▲加捻区与传动区独立分开
- ▲系列化锭子设计，最大限度降低能耗

High quality of yarn thanks to high quality of spindle

- ▲The surface of all the parts in direct contact with yarn is special surface treated to give the yarn the max. effective protection
- ▲Minimized vibration thanks to damped spindle pot mountings on rotary parts
- ▲Life lubricated pot bearings with special dustproof protection.
- ▲Pneumatic threading system for quick threading with self-cleaning yarn path.
- ▲Convenient adjustment of tension device suitable for all kinds of yarn
- ▲Twisting area is separated with drive area.
- ▲e-save spindle series

锭子是倍捻机的核心，序列化节能锭子设计和新概念传统系统是降低能耗的关键。

节能锭子序列，包含以下锭子系列：

The two-for-one spindle is the heart of TFO machine. The e-save spindles and new driving system is the key to reduce the power consumption.

The e-save spindle family includes:

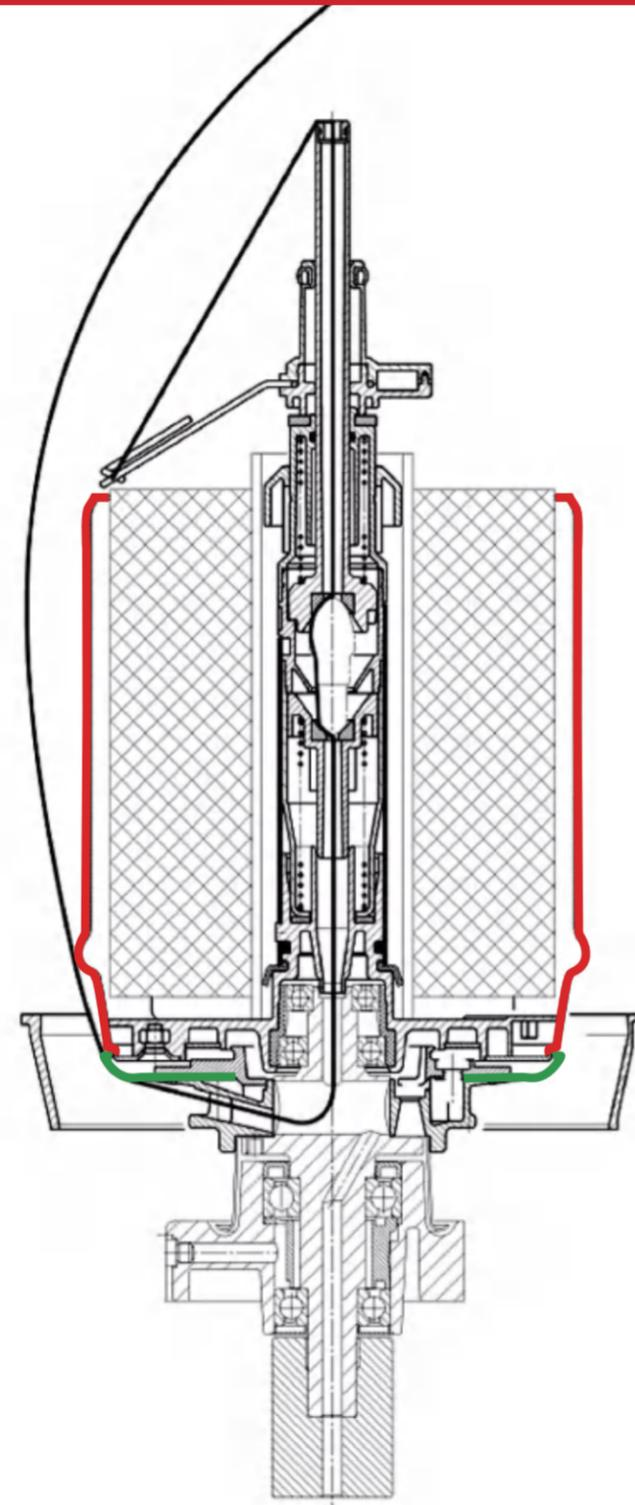

SIM-07/-07HE/-07ECO  
SIM-08/-08HE/-08ECO  
SIM-09/-09HE/-09ECO  
SIM-10/-10HE  
SIM-11

e-save 锭子系列的优势：

e-save 锭子通过优化气圈形状，能降低约40%的气圈能耗

e-save spindle can generate new yarn balloon geometry and save up to 40% balloon energy consumption



## 断纱探杆锁定装置 Locking device

当停机时，断纱探杆被锁定在工作位置。这可以防止在停机时断纱探杆下落，以保证下次正常开机。

The yarn feelers are automatically locked in their working position. It prevents the feelers dropping when the machine is stopped.



## 纱线通道的表面处理 Surface treatment

在纱线加捻的过程中，所有与纱线直接接触的部件均经过特殊表面处理，为纱线提供最有效的保护。

All elements in direct contact with the yarn feature a high-grade surface finish for optimum yarn protection.

- ▲锭翼，张力器和张力子弹  
Flyer, tension device, capsule
- ▲锭子内部纱线通道  
Spindle inner path
- ▲气圈导纱钩和断纱探杆  
Balloon guide, yarn feeler
- ▲超喂罗拉和偏转罗拉  
Over feed roller, deflection roller
- ▲横动导纱器  
Traverse guide
- ▲气圈罩  
Balloon limiter

## 选配装置 Options



气动穿纱装置(选配装置)  
Air Threading device



筒子自动抬升装置(选配装置)  
Pneumatical lifting device



纱线速度传感器(选配装置)  
Speed sensor



留尾纱装置(选配装置)  
Tail device

### 气动穿纱装置 Air Threading device

踩下刹车板可刹住锭子。进一步踩下刹车板时，压缩空气气流携带纱线进入锭子后向上，至锭罐上部，操作工可方便地抓住纱头。该装置可保证穿纱操作准确无误，并大大缩短的穿纱时间。

Threading device ensures rapid and faultless threading every time.the foot pedal stops the spinde.as the pedal is pressed down further. It's carried by the airstream up and around the spindle pot where it can easily be grasped by the operator.

### 筒子自动抬升装置 Pneumatical lifting device

断纱探杆落下，表明该锭位纱线断头或需要更换筒子。卷绕筒子经过一段时间延时后从摩擦辊筒上自动抬起，以避免筒子表面纱线受损。

In case a yarn break or feed package runout. the take-up package is lifted from the drive roller following a time delay.

### 纱线速度传感器 Speed sensor

传感器可以实时监测断纱及纱线旋转速度，防止锭速差异引起的质量问题，同时准确计算产量。

The speed sensor can detect yarn breakage and rotational speed,to aviod quality problem of spindle speed deviation.choose this sensor ,we can get precise production.

### 留尾纱装置 Tail device

自动形成换筒纱尾，换筒纱尾的长度可集中调节。

The function of the tail on the twisted package tube is automatic,The length of the tail can be centrally adjusted.

## 前挡风板 Front wall 上蜡装置 Waxing 油杯 Lubricant

能更好的保持气圈稳定和锭罐保护。  
For better balloon & pot protection.

上蜡装置和油杯的使用减少了加捻纱线在后道工序中的摩擦系数，减少毛羽、飞花、粉尘。  
Waxing and Lubricant reduce the frictional coefficient of the twisted yarn in the subsequent processes. and hairness, dust & fibre fly also will be reduced.

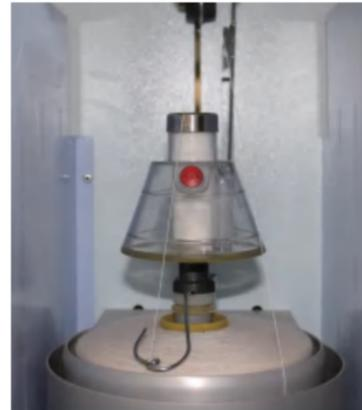
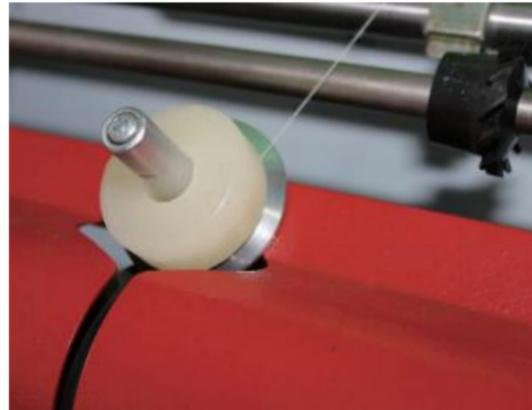

## 产量计算 Production count

$$\text{Yarn speed} = \frac{\text{锭速(转/分)} \times 2}{\text{捻度No. of twists(T/m)}} \text{ m/min}$$

$$\text{Production} = \frac{\text{锭数} \times \text{工作效率}}{\text{公支数 Nm(metric count)} \times 1000} \times \text{Yarn speed} \times \text{工作时间}$$

$$\text{Nm(metric count)} = \text{Ne(count)} \times 1.6934$$

Cotton(Ne60S/2), 800T/M, 11000r/min, 200Spindles

$$\text{Yarn speed} = \frac{11000 \times 2}{800} = 27.5 \text{ ( m/min )}$$

$$\text{Production} = \frac{27.5 \times 24 \times 60 \times 200 \times 0.98}{(60S/2=30) \times 1,6934 \times 1,000} = 152.78 \text{ Kg/Day}$$

## 技术参数 Specification

锭子型号	SIM-07	SIM-08	SIM-09	SIM-10	SIM-11
捻度范围 Tpm	80-2800T/m 2.03-71.09T/inch	80-2800T/m 2.03-71.09T/inch	80-2800T/m 2.03-71.09T/inch	80-2800T/m 2.03-71.09T/inch	80-2800T/m 2.03-71.09T/inch
锭速 Spindle speed 每分钟加入的捻度	最高11.000rpm max. 最高22.000min <sup>-1</sup> max.	最高12.500rpm max. 最高25.000min <sup>-1</sup> max.	最高13.500rpm max. 最高27.000min <sup>-1</sup> max.	最高14.500rpm max. 最高29.000min <sup>-1</sup> max.	最高15.000rpm max. 最高30.000min <sup>-1</sup> max.
支数范围 Count	Ne 4/2-100/2有气圈罩 With BL Ne 8/2-100/2无气圈罩 Without BL	Ne 8/2-170/2有气圈罩 With BL Ne 16/2-170/2无气圈罩 Without BL	Ne 20/2-200/2有气圈罩 With BL Ne 20/2-200/2无气圈罩 Without BL	Ne 30/2-200/2有气圈罩 With BL Ne 30/2-200/2无气圈罩 Without BL	适用纯棉、绢纺 Special for 100% cotton & silk Ne 60/2-200/2无气圈罩 Without BL
吸入卷装6": Feed package	φ 最大值180mm圆柱形 Max. φ 180mm Cylindrical	φ 最大值155mm圆柱形 Max. φ 155mm Cylindrical	φ 最大值135mm圆柱形 Max. φ 135mm Cylindrical	φ 最大值120mm圆柱形 Max. φ 120mm Cylindrical	φ 最大值110mm圆柱形 Max. φ 110mm Cylindrical
加捻卷装6": twisted package	圆锥角度可过5° 57' conical φ 直径最大280mm max. diameter	圆锥角度可过5° 57' conical φ 直径最大280mm max. diameter	圆锥角度可过5° 57' conical φ 直径最大280mm max. diameter	圆锥角度可过5° 57' conical φ 直径最大280mm max. diameter	圆锥角度可过5° 57' conical φ 直径最大280mm max. Diameter

## 安装图 Layout

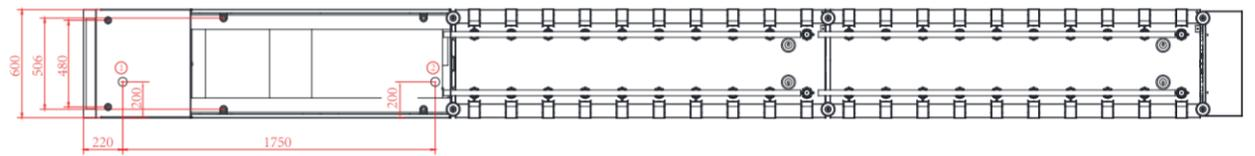
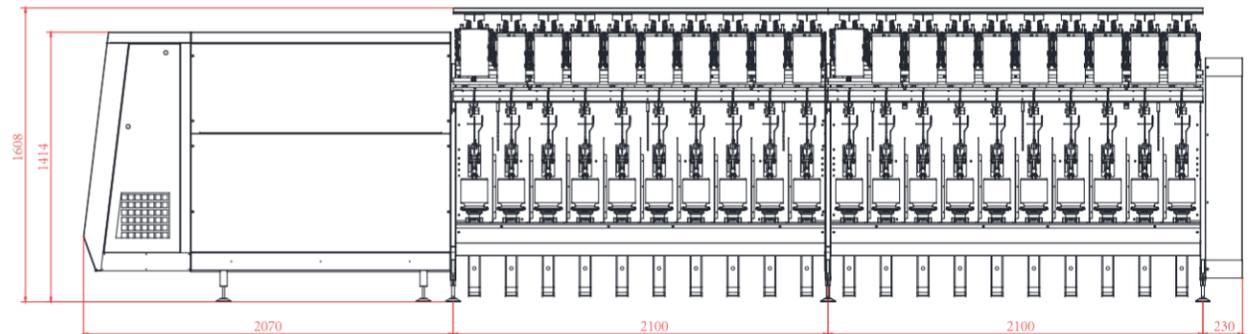

- ① 电气接口 Cable  
② 压缩空气接口G1/2 air hose

### SIM-07/08/-09/-10/-11

机器节数 No. of sectims	1	2	3	4	5	6	7	8	9	10	11	12
锭距207mm Gauge of spindle	20	40	60	80	100	120	140	160	180	200	220	240
锭距230mm Gauge of spindle	18	36	54	72	90	108	126	144	162	180	198	216
锭距258mm Gauge of spindle	16	32	48	64	80	96	112	128	144	160	176	192
锭距296mm Gauge of spindle	14	28	42	56	70	84	98	112	126	140	154	168
总重量 ( N ) Total weight	13800	18600	23400	28200	33000	37800	42600	47400	52200	57000	61800	66600
总长度 ( mm ) Total length	4400	6500	8600	10700	12800	14900	17000	19100	21200	23300	25400	27500