

www.imaginsz.com

MAGN

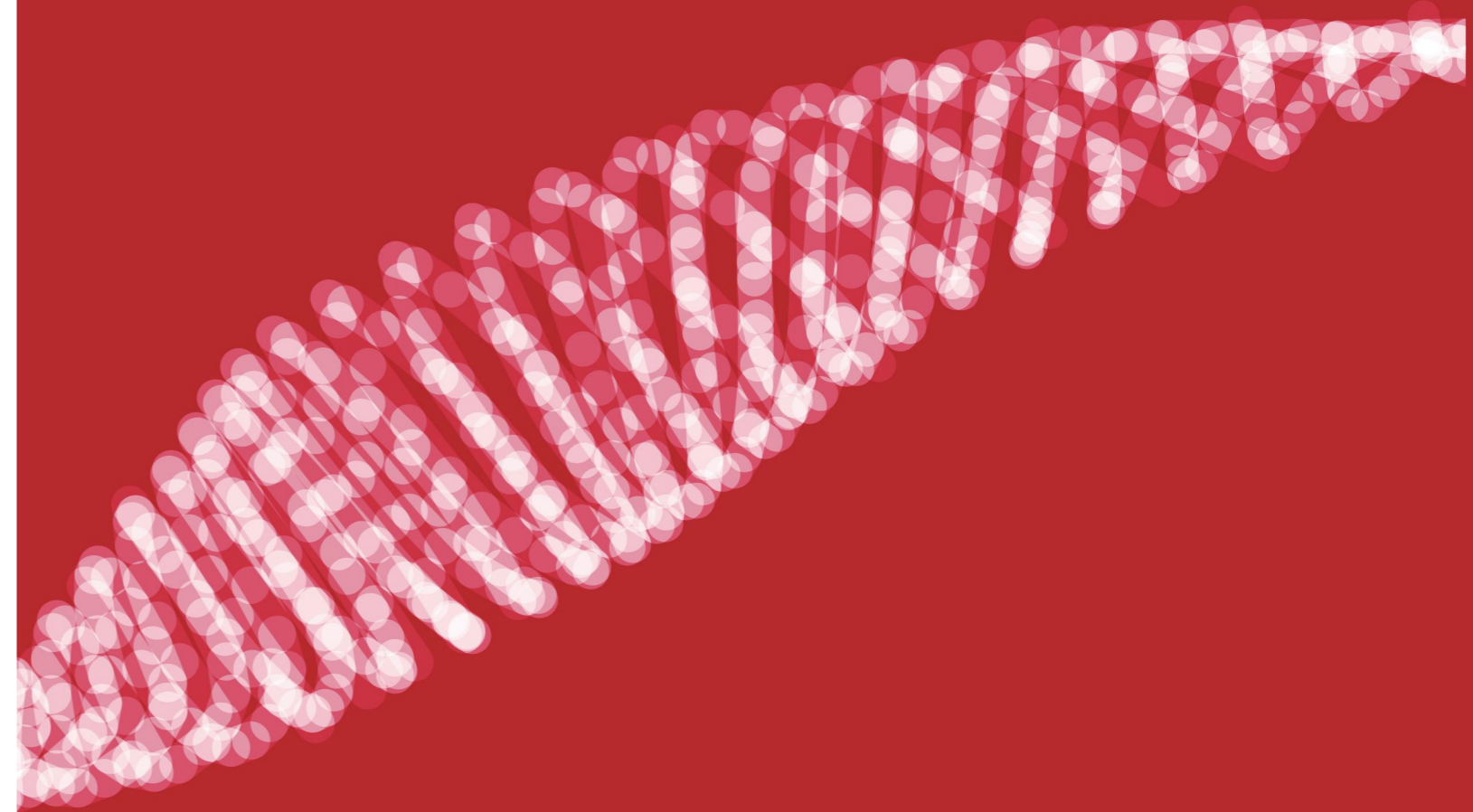

Filament Twister 化纤倍捻机

MAGN

苏州英迈杰机械有限公司
Suzhou Imagin Machinery Co.,Ltd.

地址：江苏省苏州工业园区唯文路7号 Block A, No.7 Weiwen Road, Suzhou Industrial Park, Suzhou, Jiangsu, China	江苏省南通海安市和顺路88号 No.8 Heshun Road, Hai'an Nantong, Jiangsu, China
电话：0086-512-6706 6492	Tel : 0086-512-6706 6492
传真：0086-512-6706 6493	Fax : 0086-512-6706 6493
网址：www.imaginsz.com	Http: www.imaginsz.com

- 本样本仅作参考，不作为技术验收依据。
- 为提高产品质量，本公司保留更改规格之权力，恕不另行通知。
- We reserve the right to modify the characteristics of the machines described herein without prior notice.
- The data given in this brochure are not intended as a guarantee.

苏州英迈杰机械有限公司
Suzhou Imagin Machinery Co.,Ltd.

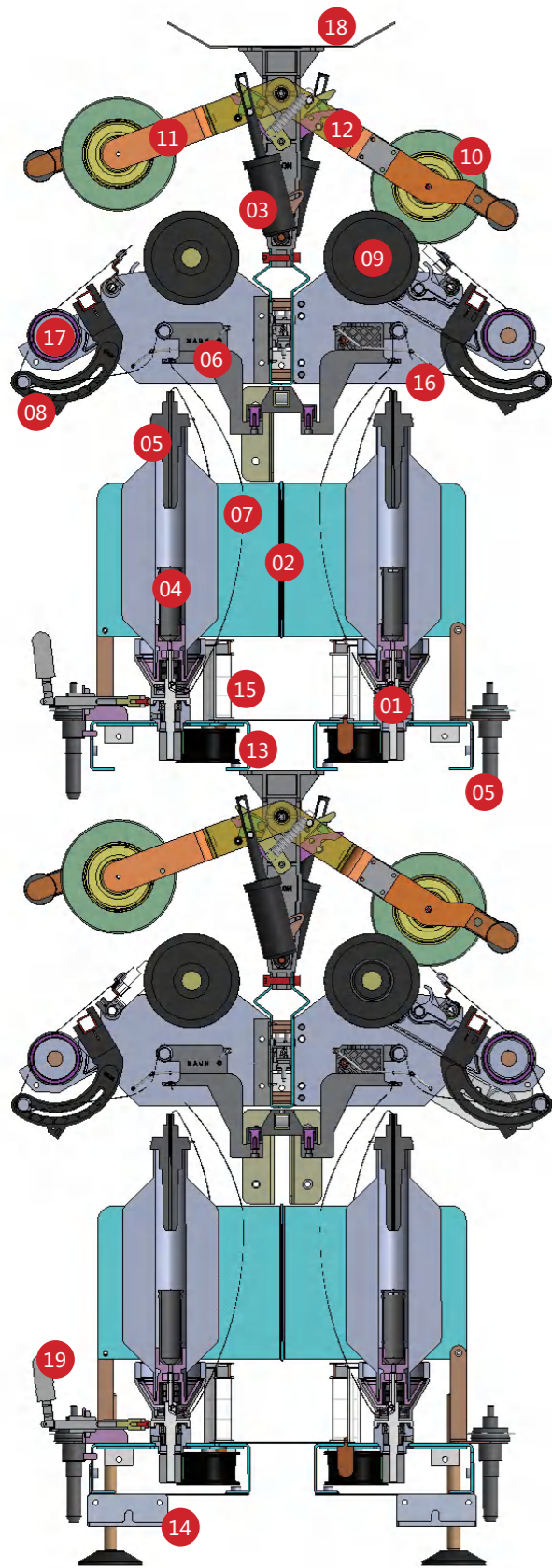

结构图 Frame section

- 01 锭子 Spindle
- 02 隔纱板 Yarn separator
- 03 抬升气缸 Lifting cylinder
- 04 喂入纱 Feed yarn
- 05 退解张力器 Unwinding tensioner
- 06 导纱座 Yarn guide base
- 07 气圈 Yarn balloon
- 08 偏转罗拉 Deflection rollers
- 09 摩擦辊 Friction roller
- 10 筒纱 Yarn package
- 11 夹片 Centering disc
- 12 摇架 Cradle
- 13 带轮 Pulley
- 14 地脚 Anchor bolt
- 15 磁铁座 Magnet base
- 16 断纱探杆 Yarn feeler
- 17 超喂罗拉 Pre-take-up roller
- 18 储纱支架 Yarn storage support
- 19 刹车装置 Brake device

技术参数 Specification

型号 Type	FT90	纱支 Yarn count	25-800D
锭距 Gauge	220mm	捻向 Twisting direction	S / Z
每节锭数 Spindles per section	36锭(双面 Two-sided)	锭子固定 Spindles fixing	磁吸式 Magnetic attraction
最大锭速 Max spindle speed	15000r/min	引纱方式 Yarn threading type	手动/气动 Manual/Pneumatic
锭子传动 Spindle transmission	龙带式 Friction belt	抬升方式 Lifting type	气动抬升 Pneumatic lifting
张力控制 Yarn tension control	分段式/集中式 Segmented / centralized	捻度范围 twisting range	80-5000T/m
配电输入 Power distribution input	380V (±7%)	配气输入 Air distribution input	0.5MPa-0.6MPa

安装图 Layout

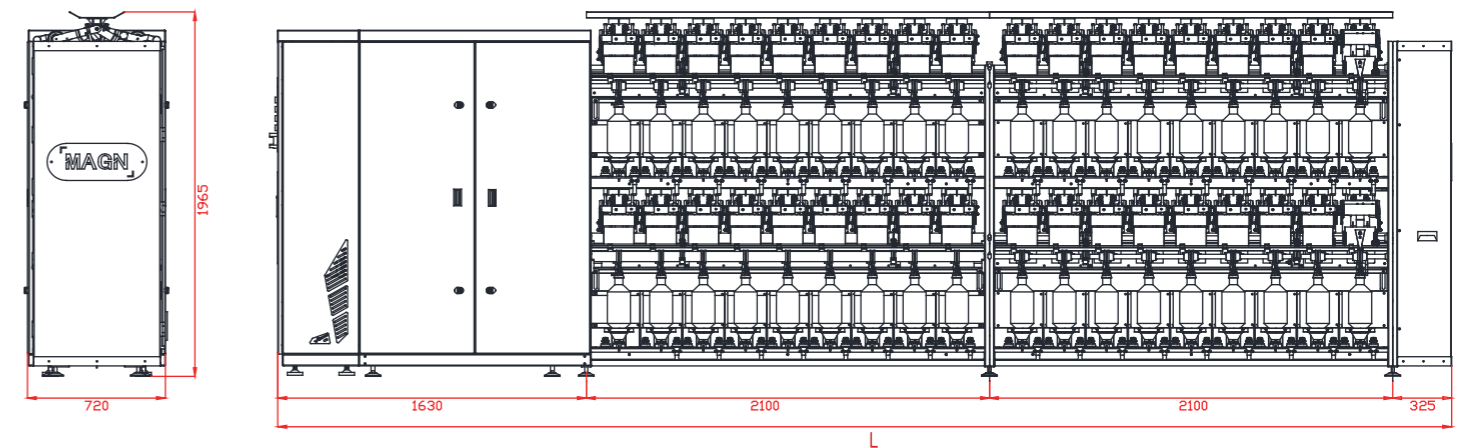

数锭 Number(Sp)	36	72	108	144	180	216	252	288	324	360
长度 Length(mm)	4055	6155	8255	10355	12455	14555	16655	18755	20855	22955
锭距 Gauge(mm)	220									
宽度 Width(mm)	720									
高度 Height(mm)	1965									
重量 Weigt(Kg)	1300	1700	2100	2500	2900	3300	3700	4100	4500	4900

锭子特点 Spindle features

- ▲ 锭子是化纤倍捻机的核心，节能型锭子设计最大限度地降低了设备能耗。
 - ▲ 所有与纱线直接接触的部件均经过特殊表面处理，给纱线最有效的保护。
 - ▲ 内部锭子轴承特殊定制化，高转速状态下锭子的震动和噪音更小。
 - ▲ 便捷式长丝专用退绕张力器，通道清理方便、结构简洁且适用多种纱支。
 - ▲ 加捻区与传动区通过护套独立分开，减少外部对纱线加捻过程的干扰。
- ▲ The spindle is the heart of C-Twister, E-save spindles reduces the energy consumption of the equipment to the maximum.
 - ▲ All parts in direct contact with the yarn are subject to special surface treatment to provide the most effective protection to the yarn.
 - ▲ The internal spindle bearing is specially customized, and the vibration and noise of the spindle are less under high rotation speed.
 - ▲ Convenient special unwinding tension device for filament, convenient channel cleaning, simple structure and applicable to a variety of yarn counts.
 - ▲ The twisting area and the driving area are separated independently by the sheath to reduce external interference to the yarn twisting process.



E-save spindle

产量计算 Production count

$$\text{Yarn speed} = \frac{\text{锭速(转/分)} \times 2}{\text{捻度 No. of twists (T/m)}} \text{ m/min}$$

$$\text{Production} = \frac{\text{纱速} \times \text{工作时间(分钟)} \times \text{锭数} \times \text{工作效率}}{\text{公支数 Nm(metric count)} \times 1000}$$

$$\text{公支数 Nm(metric count)} = 9000/D \text{ (旦尼尔 Denier)}$$

FDY(100D=90Nm), 800捻/米(T/m), 10000r/min, 288锭(Sp)

$$\text{Yarn speed} = \frac{10000 \times 2}{800} = 25 \text{ (m/min)} \quad \text{工作效率} = 0.99 \text{ (系数 coefficient)}$$

$$\text{Production} = \frac{25 \times 24 \times 60 \times 288 \times 0.99}{90 \times 1000} = 114.04 \text{ Kg/天 (114.04Kg/Day)}$$

产品优势 Product advantages

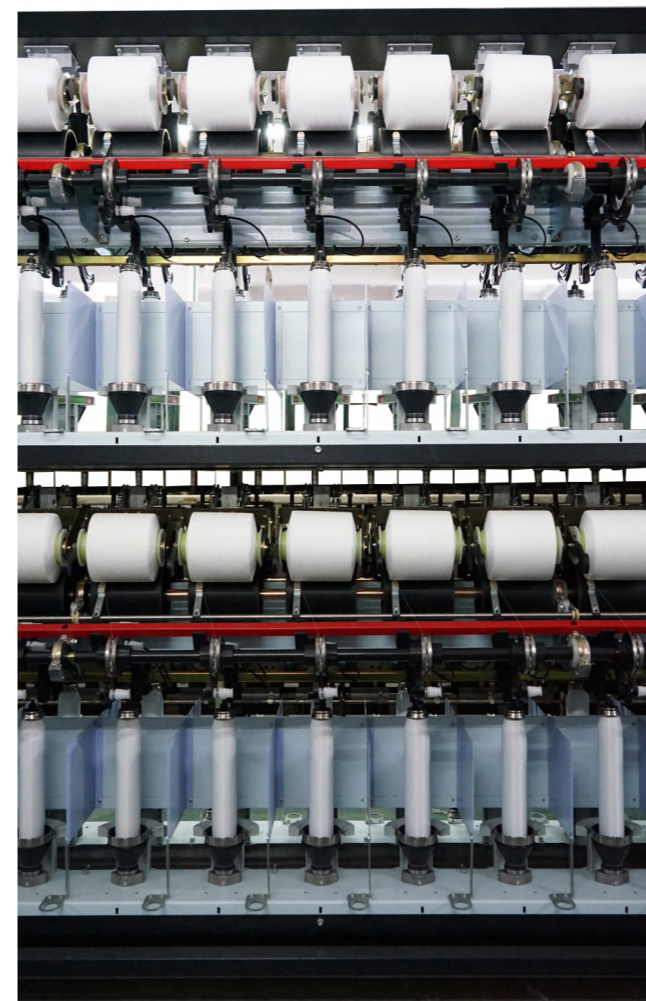

No.1 节能型锭子 E-save spindle

- ★ 锭轴动平衡校检处理
Spindle dynamic balance calibration
- ★ 进口轴承一体化封装
Imported bearings integrated assembly
- ★ 驱动能耗更低、转速更快
Lower energy consumption, faster speed

No.2 智能化系统 Intelligent system

- ★ 一键工艺参数设定
All parameters touch screen setting
- ★ 横动机构伺服全控制
Full servo control of traverse mechanism
- ★ 卷绕机构伺服全控制
Full servo control of winding mechanism

No.3 维护便捷 Convenient maintenance

- ★ 机节高度设置便于操作维护
The section height is set for operation easy
- ★ 免维护锭子，锭子不需要更换润滑油
Maintenance free spindle without changing oil
- ★ 操作软件版本定期升级
The software version is updated regularly

No.4 功能全面 Full-featured

- ★ 气动抬升摇架标准配置
Standard configuration of pneumatic lifting cradle
- ★ 气动穿纱系统可选配
Optional pneumatic threading system
- ★ 纱线长度精准测算系统
The accurate measuring system of yarn length

传动方式 Transmission



智能控制 Intelligent Control

伺服控制系统主要由PLC、伺服驱动器、变频控制单元及动力电机组成。

- ▲ PLC：可编程逻辑控制器
- ▲ 伺服驱动器：高精度定位及信号传递
- ▲ 变频控制单元：工频电源转换及节能
- ▲ 驱动电机：加捻、横动及卷绕动力提供

The servo control system is mainly composed of PLC, servo driver, frequency conversion control unit and power motors.

- ▲ PLC：Programmable logic controller
- ▲ Servo driver：High precision positioning and signal transmission
- ▲ Frequency control unit：Frequency power conversion and energy saving
- ▲ Drive motors：Twisting, traversing and winding power supply

伺服驱动可以帮您实现： Servo drive can help you achieved：

- | | |
|---------------------|---|
| ▲ 锭子最大转速15000r/min | ▲ Maximum spindle speed 15000r/min |
| ▲ 一键参数设置，捻度按工艺需求设定 | ▲ One key setting, TPM fit your requirements |
| ▲ 电子收边及防叠丝功能 | ▲ Electronic edging and anti overlap function |
| ▲ 横动及卷绕部位无油润滑，免维护 | ▲ Oil free lubrication, maintenance free |
| ▲ 最大卷取速度120m/min | ▲ Maximum winding speed 120m/min |
| ▲ 传动效率高，能效节约12.5%以上 | ▲ Transmission efficiency, e-saving more than 12.5% |

气动抬升 Automatic lifting

气动抬升控制系统主要由断纱探杆、线阀、中心阀、抬升气缸组成。

- ▲ 断纱后摇架自动抬起分离，避免纤维过度摩擦
- ▲ 减少人工巡视的劳动强度，提高产量和效率

The pneumatic lifting control system is mainly composed of yarn breaking probe, wire valve, central valve and lifting cylinder.

- ▲ The cradle lifts and separates after yarn breaking to avoid fiber friction
- ▲ Reduce labor intensity of inspection and improve the output and efficiency

