

APEM

KS Series

CAN Integrated Multiplex System

- CAN BUS
- Increased reliability
- Flexible and expandable system
- Reduced wiring costs

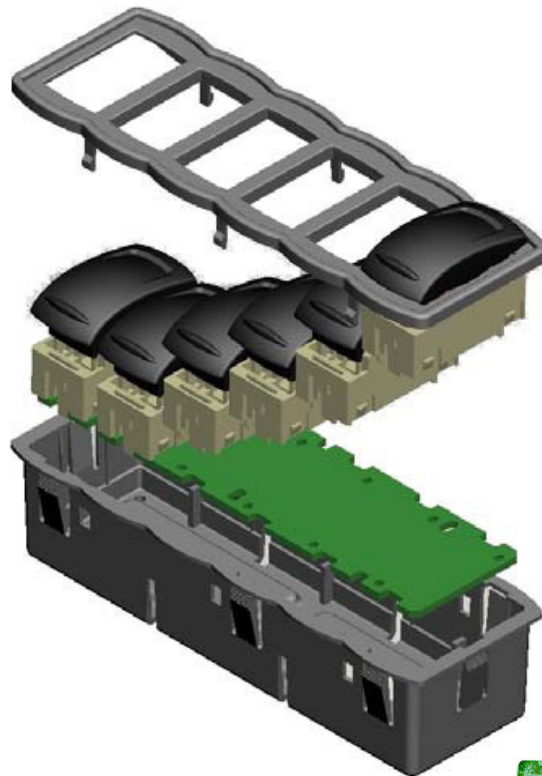

Applications:

- Passengers cars and buses
- Heavy duty vehicles
- Machine control panel
- Boats
- Etc...

TABLE OF CONTENTS

| | | |
|-------------|--|-----------|
| I. | KS SYSTEM | 3 |
| I.1 | OVERVIEW..... | 3 |
| I.2 | MAIN FUNCTIONS OF THE KS SYSTEM..... | 4 |
| I.3 | ADVANTAGES OF THE KS SYSTEM..... | 4 |
| I.4 | FEATURES..... | 4 |
| II. | KS MODULE | 5 |
| II.1 | DESCRIPTION..... | 5 |
| II.2 | MODEL STRUCTURE..... | 6 |
| II.3 | SLAVE AND MASTER MODULE COMMON SPECIFICATIONS..... | 6 |
| III. | ROCKER SWITCH KSA | 7 |
| III.1 | OVERVIEW..... | 7 |
| III.2 | MECHANICAL SPECIFICATIONS..... | 7 |
| III.3 | MATERIALS..... | 7 |
| III.4 | DIMENSIONS..... | 7 |
| III.5 | SELECTION GUIDE..... | 8 |
| IV. | PRINTED CIRCUIT BOARD KSB | 17 |
| IV.1 | OVERVIEW..... | 17 |
| IV.2 | ABSOLUTE MAXIMUM RATINGS..... | 17 |
| IV.3 | MACHINE INTERFACE..... | 18 |
| IV.4 | MECHANICAL INTERFACES..... | 19 |
| IV.5 | ELECTRICAL INTERFACES..... | 20 |
| IV.6 | SOFTWARE INTERFACES..... | 22 |
| IV.7 | PIN ALLOCATION..... | 26 |
| IV.8 | CABLES..... | 27 |
| IV.9 | ENVIRONMENT CHARACTERISTICS..... | 28 |
| IV.10 | MASTER FULL EQUIPPED..... | 29 |
| IV.11 | SLAVE FULL EQUIPPED..... | 30 |
| IV.12 | MASTER LIGHT..... | 31 |
| IV.13 | SLAVE LIGHT..... | 32 |
| IV.14 | SELECTION GUIDE..... | 32 |
| IV.15 | ACCESSORIES..... | 33 |

I. KS SYSTEM

I.1 OVERVIEW

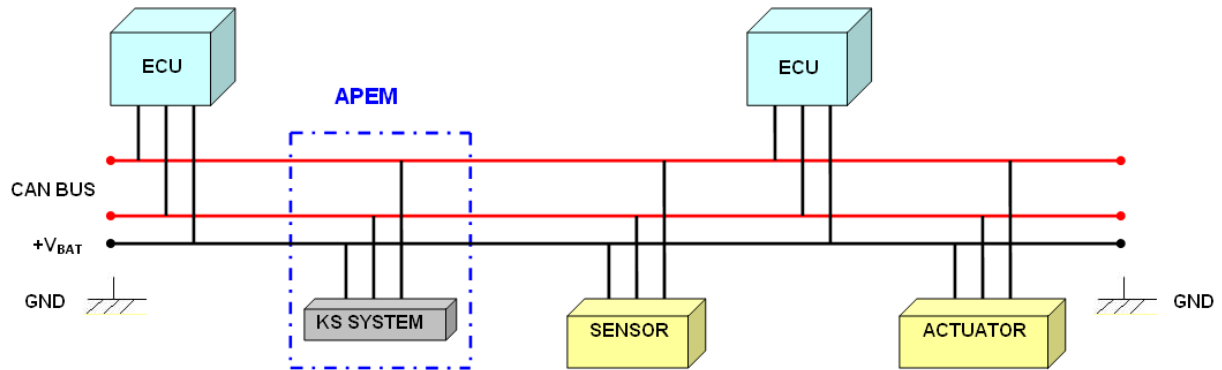

The KS System communicates with ECU (Electronic Control Unit) through a multiplexed CAN network.

The KS system is described below:

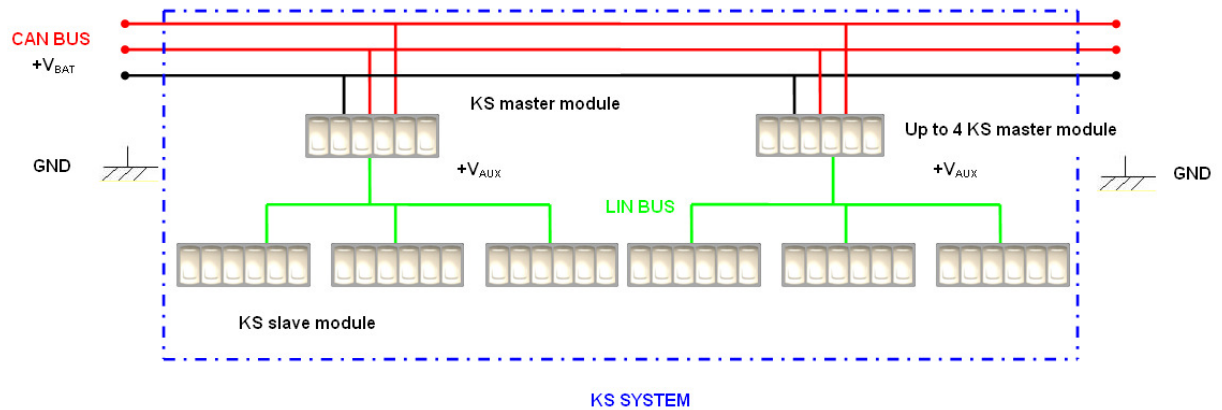

The APEM KS Series is a mechatronics concept integrating rocker switches and electronics.

I.2 MAIN FUNCTIONS OF THE KS SYSTEM

- The two main functions of the KS system are:
 - Take the information of the switches position (activated or not) and send this information on the CAN network.
 - Receive from the CAN network the information concerning the status of the LED (on, off, value of backlight).

Two module variants: master Module and Slave Module

- Up to 4 master module and up to 3 slave module per master module
- Up to 96 switches in a KS System

I.3 ADVANTAGES OF THE KS SYSTEM

- **Increased reliability**
- **Flexible and expandable system**
- **Reduce wiring costs**

I.4 FEATURES

The Generic KS module is an embedded electronic dashboard module.

Main features :

- ✓ Compliant to 12V and 24V applications
- ✓ Up to 4 master KS modules on a CAN bus line
- ✓ Up to 3 slave KS modules per master KS module
- ✓ Up to 6 switches 3 positions (12 micro-switches)
- ✓ Up to 12 Leds for pictogram lighting
- ✓ 1 CAN line 250 kbaud ISO18898 on master KS module
- ✓ 1 LIN line Rev 2.0
- ✓ Wake up on CAN
- ✓ Wake up on switch
- ✓ ACTIGRAF VE 01.29 compliant
- ✓ ROHS compliant

Typical vehicle application :

- ✓ Interior driving deck
- ✓ Dashboard extension

II. KS MODULE

II.1 DESCRIPTION

Module (slave or master)

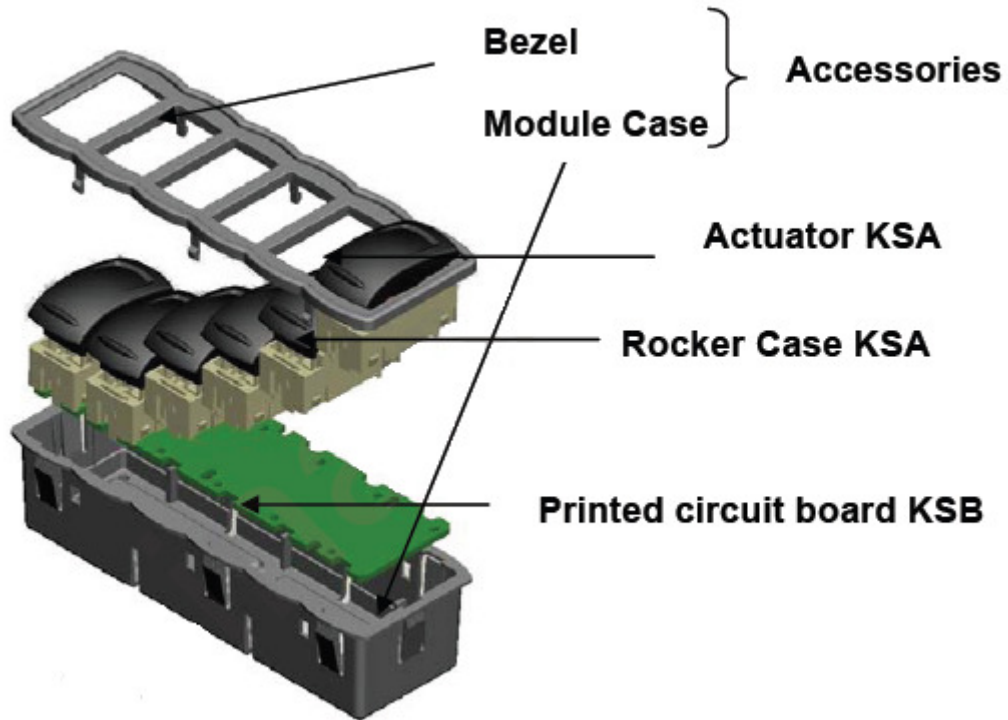

II.2 MODEL STRUCTURE

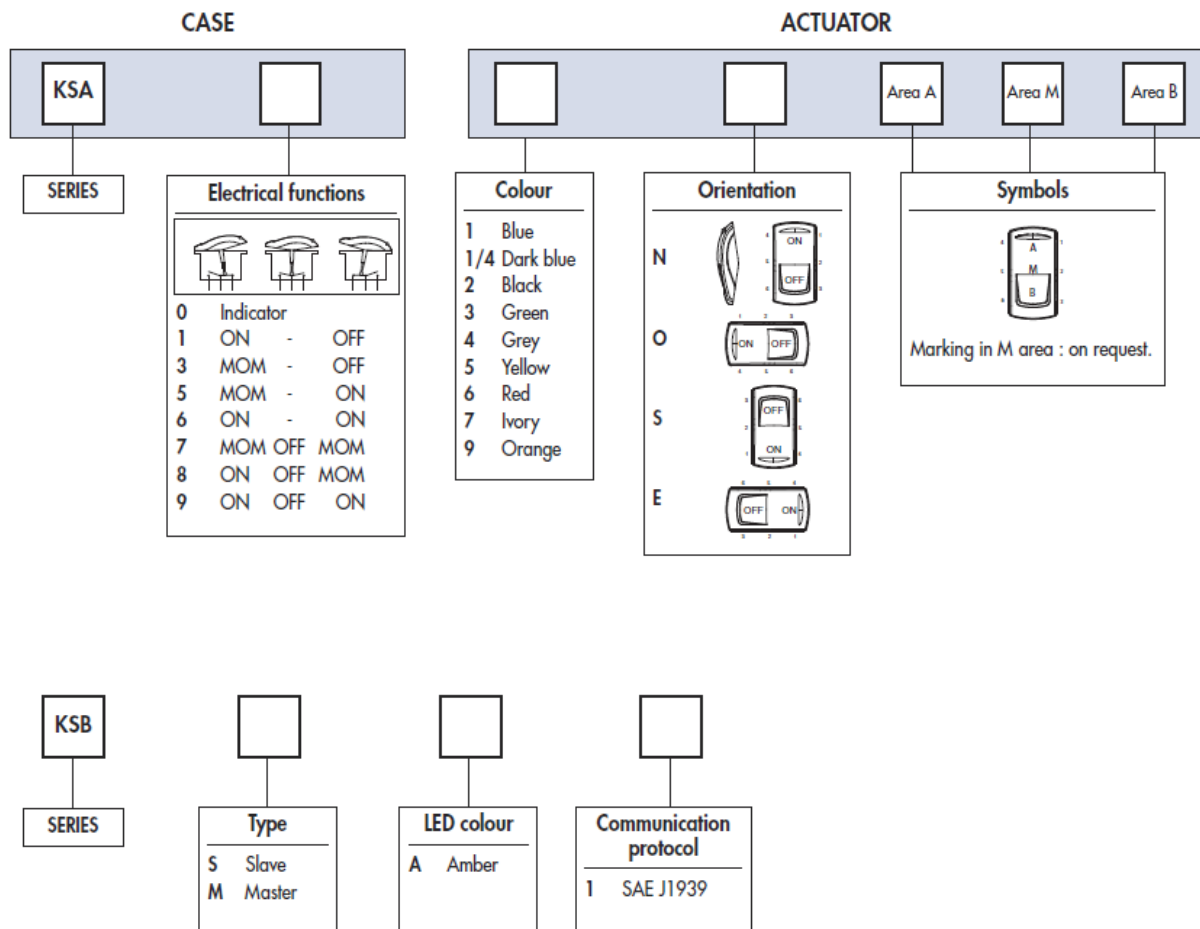

II.3 SLAVE AND MASTER MODULE COMMON SPECIFICATIONS

- up to 6 switches x 3 positions

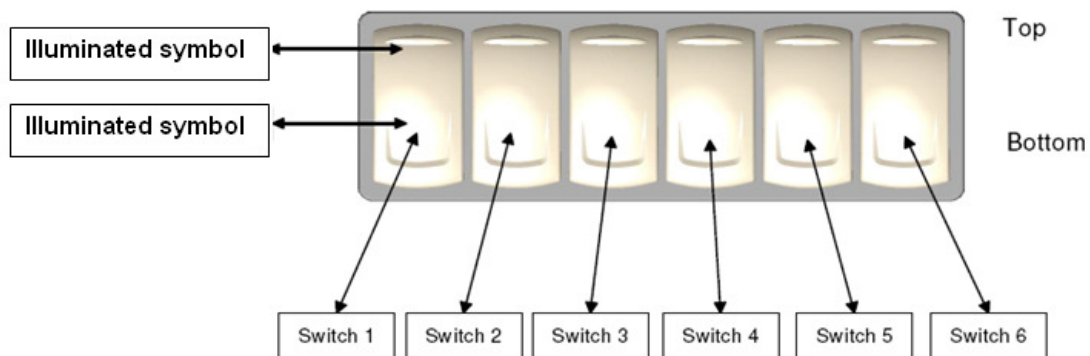

The rocker switch

- Wide choice of actuator colours (up to 9)
- Laser etched symbols
- Illuminated or non-illuminated
- Full separation of the electrical and mechanical parts

III. ROCKER SWITCH KSA

III.1 OVERVIEW

The KSA rocker switch is made up of 2 different parts: an actuator and a rocker case. It is possible to order the complete rocker (actuator + rocker case) or separately the actuator and the rocker case.

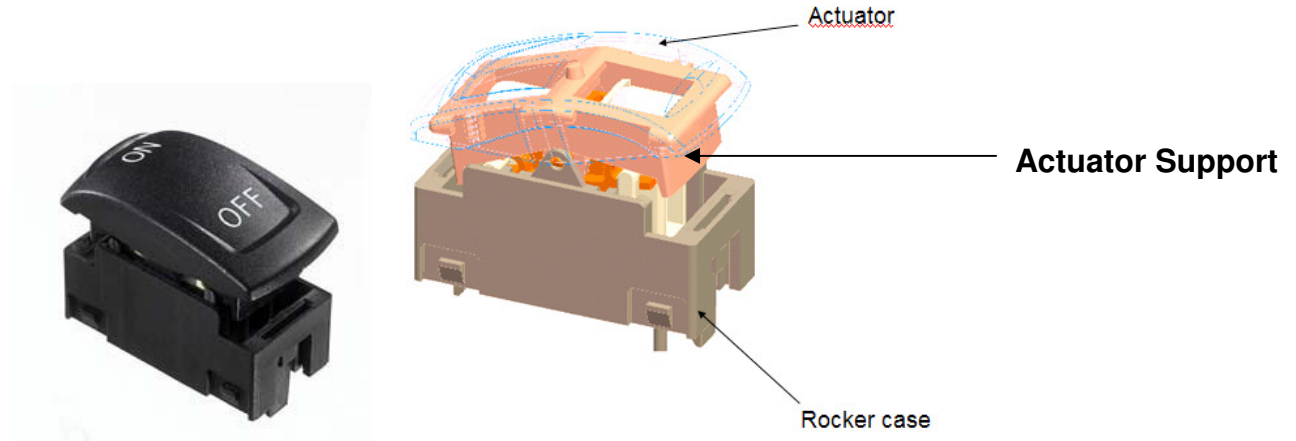

III.2 MECHANICAL SPECIFICATIONS

- 1.000.000 cycles min

III.3 MATERIALS

- Case : PA 6-6
- Actuator : ABS



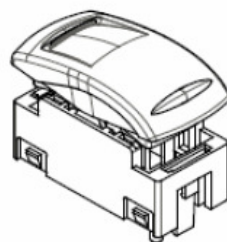
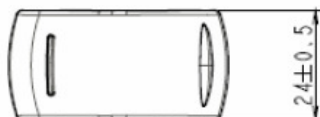
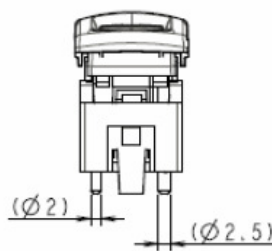
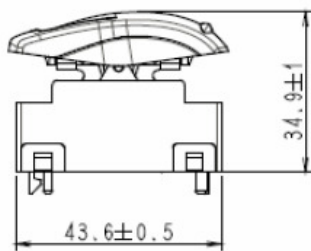



III.4 DIMENSIONS



III.5 SELECTION GUIDE

HOW TO ORDER

- To order a complete product, fill in all the boxes of the following order guide.
- To order actuator only (without case), begin the order number with code KSR, then follow the order format from "actuator colour" until the end of the options.

| CASE | | ACTUATOR | | | |
|--------|--|---|--|--|--------|
| KSA | [] | [] | Area A | Area M | Area B |
| SERIES | Electrical functions | Colour | Orientation | Symbols | |
| |  0 Indicator 1 ON - OFF 3 MOM - OFF 5 MOM - ON 6 ON - ON 7 MOM OFF MOM 8 ON OFF MOM 9 ON OFF ON | 1 Blue 1/4 Dark blue 2 Black 3 Green 4 Grey 5 Yellow 6 Red 7 Ivory 9 Orange | N  O  S  E  |  Marking in M area : on request. | |

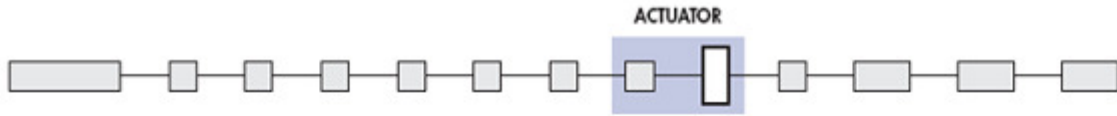
ACTUATOR COLOUR

| Code | Colour |
|------|-----------|
| 1 | Blue |
| 1/4 | Dark blue |
| 2 | Black |
| 3 | Green |

| Code | Colour |
|------|--------|
| 4 | Grey |
| 5 | Yellow |
| 6 | Red |
| 7 | Ivory |

| Code | Colour |
|------|--------|
| 9 | Orange |

Note : colours A, 5 and 7 not available on illuminated versions.
A soft-touch varnish can be added. Consult us.

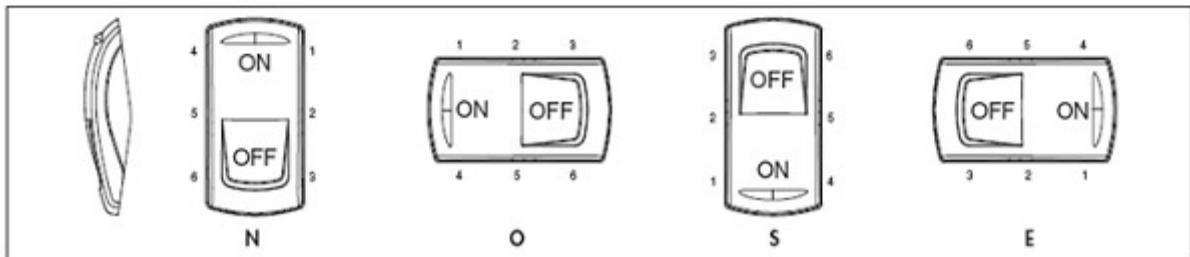
MARKING ORIENTATION If no marking required, leave box blank.

Other orientations : on request

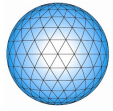

SYMBOLS

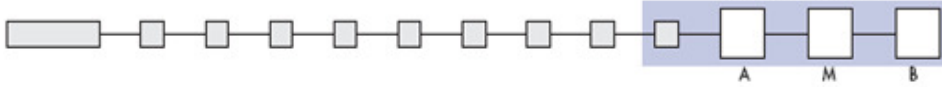

White marking for illuminated rockers and non-illuminated black rockers.
 Black marking for non-illuminated colour rockers. Other : on request.
 Marking in M area : on request.

Most symbols meet the ISO 7000 standard "graphical symbols for use on equipments" (code given in bracket in the description).
 Contact us for symbols not featured in the following tables.

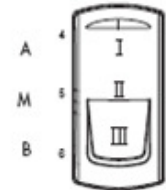

| CODE | SYMBOL | DESCRIPTION |
|------|-------------|-----------------------|
| XX | None | - |
| 01 | ON | - |
| 02 | OFF | - |
| 03 | O | - |
| 04 | I | - |
| 05 | II | - |
| 06 | STOP | - |
| 07 | A | Stop |
| 08 | M | Motion |
| 09 | ▲ | Up motion |
| 10 | ▼ | Down motion |
| 11 | | Hot |
| 12 | | Cold |
| 13 | | Hazard warning (0085) |

| CODE | SYMBOL | DESCRIPTION |
|------|--------|--------------------------------------|
| 14 | | Traveller lighting |
| 15 | | Driver lighting (1421) |
| 16 | | Revolving light |
| 17 | | Rear ventilator |
| 18 | | Heating (0637) |
| 19 | | Door opening |
| 20 | | Windshield demister/defroster (0635) |
| 21 | | Windshield wiper (0086) |
| 22 | | Windshield washer (0088) |
| 23 | | Ventilator fan (0089) |
| 24 | | Side mirror defroster |
| 25 | | Restarting pump |
| 26 | | Front fog lights (0633) |
| 27 | | Rear fog lights (0634) |

Marking area

For illuminated versions.
 The symbol will be included in the hatched area.

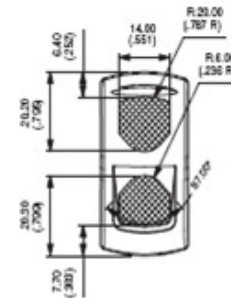

Symbol scale : 1:1 (standard).
 Other : on request.

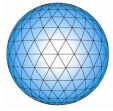

SYMBOLS

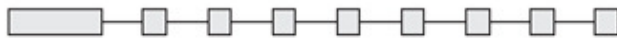

ACTUATOR MARKING

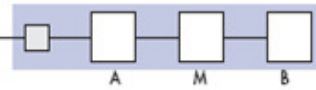

White marking for illuminated rockers and non-illuminated black rockers.
 Black marking for non-illuminated colour rockers. Other : on request.
 Marking in M area : on request.

Most symbols meet the ISO 7000 standard "graphical symbols for use on equipments" (code given in bracket in the description).

Contact us for symbols not featured in the following tables.

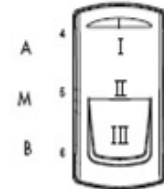

Symbol scale : 1:1 (standard).
 Other : on request.

| CODE | SYMBOL | DESCRIPTION |
|------|--------|---------------------------------------|
| 28 | | - |
| 29 | | Beacon (1141) |
| 30 | | - |
| 31 | | Electric motor (0011) |
| 32 | | Emergency first aid vehicle (2565) |
| 33 | | Load tipping (1557) |
| 34 | | Loading light (2457) |
| 35 | | Tractor, rear-ward (0089) |
| 36 | | Combine, direction of movement (1678) |
| 37 | | Use no forks (2406) |
| 38 | | Transmission (1166) |
| 39 | | Working spot light (1145) |
| 40 | | Engine (0634) |
| 41 | | Horn (0244) |

| CODE | SYMBOL | DESCRIPTION |
|------|------------|---------------------------|
| 42 | | Lock (1656) |
| 43 | | Taxi sign light (2551) |
| 44 | | Flood light (1024) |
| 45 | | - |
| 46 | | - |
| 47 | ASM | - |
| 48 | | - |
| 49 | | Differential lock (1662) |
| 50 | | - |
| 51 | | - |
| 52 | | - |
| 53 | N | - |
| 54 | | Rear window wiper (0097) |
| 55 | | Rear window washer (0099) |

| CODE | SYMBOL | DESCRIPTION |
|------|--------|-------------------|
| 56 | | Lower load (2223) |
| 57 | | Cab lock (1560) |
| 58 | | Extraction |
| 59 | | Pumping in |
| 60 | | Rear PTO (1572) |
| 61 | | Front PTO |
| 62 | | Rockshaft down |
| 63 | | Rockshaft up |
| 64 | | Indicator |

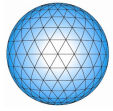

SYMBOLS



ACTUATOR MARKING

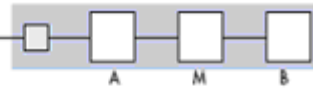

White marking for illuminated rockers and non-illuminated black rockers.
 Black marking for non-illuminated colour rockers. Other : on request.
 Marking in M area : on request.

Most symbols meet the ISO 7000 standard "graphical symbols for use on equipments" (code given in bracket in the description).

Contact us for symbols not featured in the following tables.

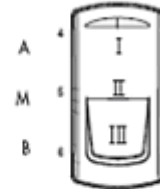

| CODE | SYMBOLE | DESCRIPTION | CODE | SYMBOLE | DESCRIPTION |
|------|----------------|----------------------------|------|----------------|--------------------------|
| 65 | | Desserer le frein Iso 0021 | 77 | | Pump |
| 66 | | baggage room left door | 78 | WC | Toilet |
| 67 | | baggage room right door | 79 | | Toilet Decontamination |
| 68 | | Power blinds | 80 | | Front windshield heating |
| 69 | | Engine idle control | 81 | AUS | AUS |
| 70 | CRUISE RES/SET | CRUISE RES/SET | 82 | | Radiator FAN |
| 71 | | Driver windows up/down | 83 | | Remove retarder |
| 72 | | Middle door opening | 84 | | Restricted speed |
| 73 | | Front door opening | 85 | | Preheater Iso 0457 |
| 74 | | Lighting in baggage room | 86 | | ABS detection Iso 1407 |
| 75 | CRUISE ON/OFF | CRUISE on/off | 87 | | ECAS detection |
| 76 | TV | TV | 88 | | Engine Stop Iso 1180 |
| | | | 89 | CRUISE RES/CAN | CRUISE RES/cancel |

Symbol scale : 1:1 (standard).
 Other : on request.

SYMBOLS







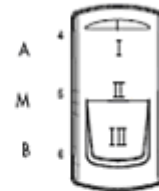















White marking for illuminated rockers and non-illuminated black rockers.
 Black marking for non-illuminated colour rockers. Other : on request.
 Marking in M area : on request.

Most symbols meet the ISO 7000 standard "graphical symbols for use on equipments" (code given in bracket in the description).

Contact us for symbols not featured in the following tables.



Symbol scale : 1:1 (standard).
 Other : on request.

| CODE | SYMBOLE | DESCRIPTION | CODE | SYMBOLE | DESCRIPTION |
|------|---|-----------------------------|------|---|-------------------------------|
| 90 |  | ECAS Reset | A3 |  | Rotation cabine anti horaire |
| 91 |  | Driver windows heating | A4 |  | Repliage faucheuse |
| 92 |  | CRUISE set | A5 |  | Dépliage faucheuse |
| 93 |  | Air bag up/down | A6 |  | Frein de parking Iso 0238 |
| 94 |  | Read lighting | A7 |  | Relevage tapis |
| 95 |  | Lighting main switch | A8 |  | Descente tapis |
| 96 |  | heating using water | A9 |  | Amplificateur de voix |
| 97 |  | Feux de croisement Iso 0093 | AA |  | Sortie rampe latérale droite |
| 98 |  | Feux de position Iso 0456 | AB |  | Rentrée rampe latérale droite |
| 99 |  | Diesel Accélération | AC |  | Sortie rampe latérale gauche |
| A1 |  | Mode manuel | AD |  | Rentrée rampe latérale gauche |
| A2 |  | Rotation cabine horaire | AE |  | Déverrouillage |

SYMBOLS















White marking for illuminated rockers and non-illuminated black rockers.
 Black marking for non-illuminated colour rockers. Other : on request.
 Marking in M area : on request.











Most symbols meet the ISO 7000 standard "graphical symbols for use on equipments" (code given in bracket in the description).

Contact us for symbols not featured in the following tables.



Symbol scale : 1:1 (standard).
 Other : on request.

| CODE | SYMBOLE | DESCRIPTION |
|------|---|---|
| AF |  | Spécifique client |
| AG |  | Condition de charge de batterie |
| AH |  | Indicateurs de direction |
| AJ |  | Feux de route |
| AK |  | Blocage du différentiel |
| AL |  | Brossage au moyen d'une brosse circulaire |
| AM |  | Véhicule 4 x 4 à boîte de transfert à blocage de différentiel central |
| AN |  | Godet de chargeuse, libre/flottant |
| AP |  | Godet de chargeuse |
| AQ |  | Essuie-glace et lave-glace de lunette arrière |
| AR |  | Godet de chargeuse |
| AS |  | Pelle rétrocaveuse déport de la flèche |
| AT |  | Traitement chimique de l'eau |

| CODE | SYMBOLE | DESCRIPTION |
|------|---|---|
| AU |  | Debusqueuse a grappin, flèche simple fonction |
| AV |  | Spécifique client |
| AW |  | Spécifique client |
| AY |  | Spécifique client |
| AZ |  | Spécifique client |
| B1 | HIGH | Spécifique client |
| B2 | LOW | Spécifique client |
| B3 |  | Spécifique client |
| B4 | SOS | |
| B5 |  | Spécifique client |
| B6 |  | Spécifique client |
| B7 |  | Spécifique client |
| B8 |  | Spécifique client |

| CODE | SYMBOLE | DESCRIPTION |
|------|---|-------------------|
| B9 |  | Spécifique client |
| BA |  | Spécifique client |
| BB |  | Spécifique client |
| BC |  | Spécifique client |
| BD |  | Spécifique client |
| BE |  | Spécifique client |







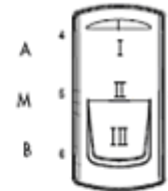

















SYMBOLS

White marking for illuminated rockers and non-illuminated black rockers.
 Black marking for non-illuminated colour rockers. Other : on request.
 Marking in M area : on request.

Most symbols meet the ISO 7000 standard "graphical symbols for use on equipments" (code given in bracket in the description).
 Contact us for symbols not featured in the following tables.



Symbol scale : 1:1 (standard).
 Other : on request.

| CODE | SYMBOLE | DESCRIPTION | CODE | SYMBOLE | DESCRIPTION |
|------|---|-------------------|------|---|---|
| BF |  AUTOPILOT | Spécifique client | BU |  | Défaillance du système de freinage |
| BG |  DEVICE | Spécifique client | BV |  ADD WATER | Add Water |
| BH |  DEVICE | Spécifique client | BW |  PUMP OUT | Pump out |
| BJ |  CABIN HEATER | Spécifique client | BY |  | Reverse Horn |
| BK |  WEATHER | Spécifique client | BZ |  | T° du fluide de refroidissement du moteur |
| BL |  STANDBY VACUUM | Spécifique client | C1 |  | Epannage |
| BM |  STANDBY ALT | Spécifique client | C2 |  | Groupage |
| BN |  BATTERY MASTER | Spécifique client | C3 |  | Moteur alternatif à combustion interne |
| BP |  AVIONICS MASTER | Spécifique client | C4 |  | Plus, augmentation, polarité positive |
| BQ |  ALTERNATOR | Spécifique client | C5 |  | Moins, diminution, polarité négative |
| BR |  FUEL PUMP | Spécifique client | C6 | XENON | Xénon |
| BS |  AUX | Spécifique client | C7 |  | Spécifique client |
| BT | REV | REVERSE | C8 |  | Lièvre |

SYMBOLS







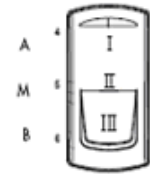















White marking for illuminated rockers and non-illuminated black rockers.
 Black marking for non-illuminated colour rockers. Other : on request.
 Marking in M area : on request.

Most symbols meet the ISO 7000 standard "graphical symbols for use on equipments" (code given in bracket in the description).

Contact us for symbols not featured in the following tables.



Symbol scale : 1:1 (standard).
 Other : on request.

| CODE | SYMBOLE | DESCRIPTION | CODE | SYMBOLE | DESCRIPTION |
|------|---|---|------|---|-------------------|
| C9 |  | Tortue | CN |  | Spécifique client |
| CA |  | Déverrouillage godet | CP |  | Spécifique client |
| CB |  | Montée / Descente | CQ |  | Spécifique client |
| CC |  | Aucune réponse de l'opérateur de la station éloignée Iso 1951 | CR |  | Spécifique client |
| CD |  | Point lumineux | CS |  | Spécifique client |
| CE |  | Emergency pump | CT |  | Alarme iso 2301 |
| CF | TEST | Test | CU | CAFS | Cafs |
| CG |  | Stairs light Iso 1144 | CV |  | Spécifique client |
| CH | CLUTCH | Clutch | CW |  | Spécifique client |
| CJ |  | Eclairage du tableau de bord / des instruments Iso 1556 | CY |  | Spécifique client |
| CK |  | Refroidissement / conditionnement d'air Iso 0027 | CZ | CLOSED | Closed |
| CL |  | Overloading free | D1 | OPEN | Open |
| CM |  | Winch speed | D2 |  | Spécifique client |

| CODE | SYMBOLE | DESCRIPTION |
|------|---|-------------------|
| D3 |  | Spécifique client |

IV. PRINTED CIRCUIT BOARD KSB

IV.1 OVERVIEW

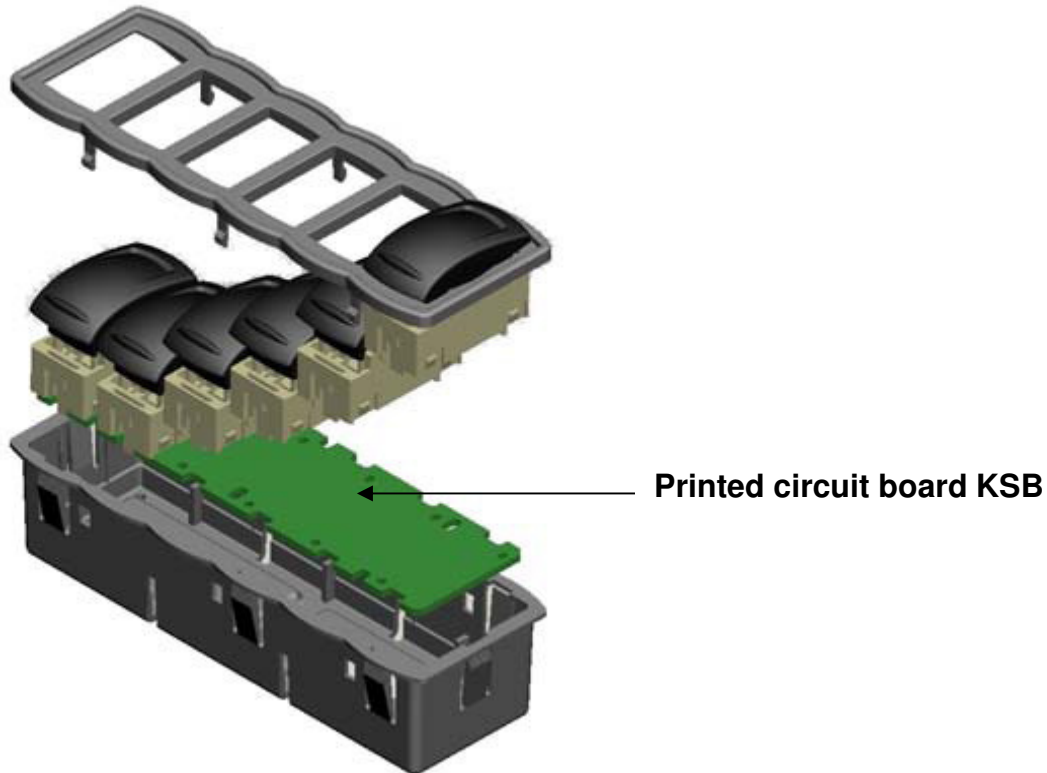

IV.2 ABSOLUTE MAXIMUM RATINGS

Power supply and temperature parameters:

| | Unit | min | Typ | Max | Conditions |
|-----------------------------|------|------|-----|-----|------------|
| Storage temperature | °C | - 40 | - | +85 | |
| Working temperature | °C | - 40 | - | +70 | - |
| Power supply voltage | V | 8 | - | 32 | - |
| Overvoltage | V | - | - | 36 | 5 min |
| Load dump | V | | | 58 | |

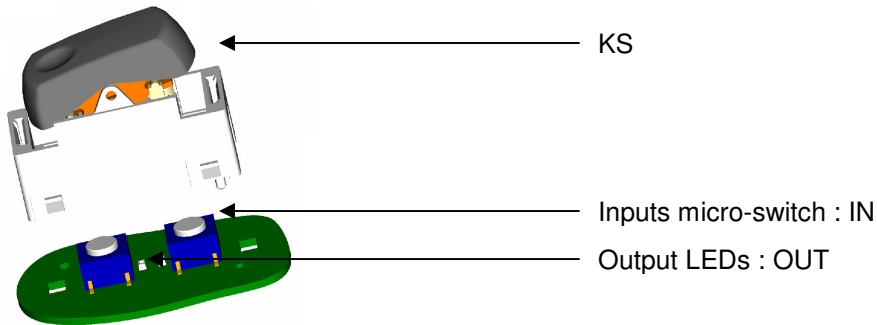
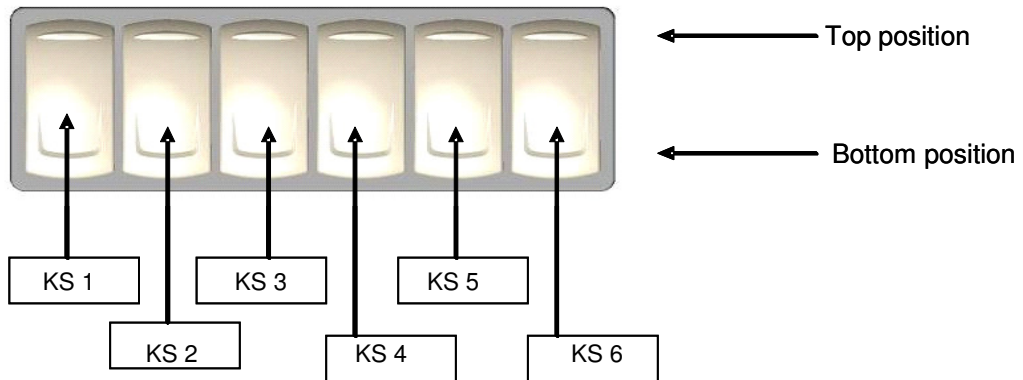
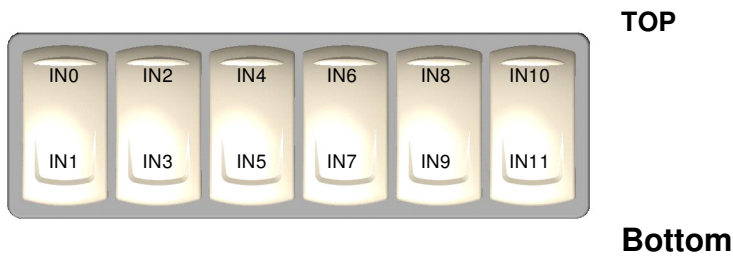
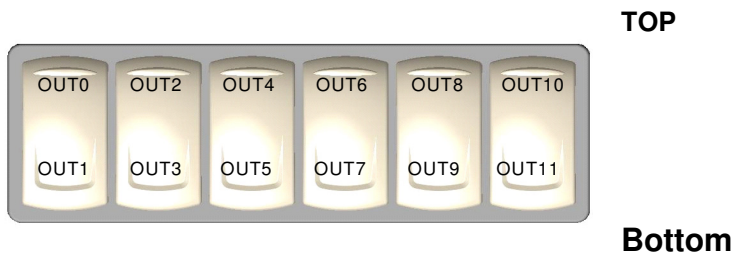
IV.3 MACHINE INTERFACE

IV.3.1 KS position:

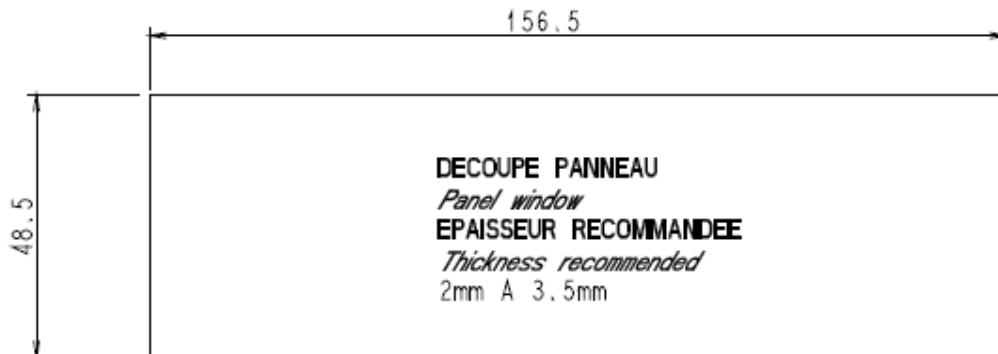
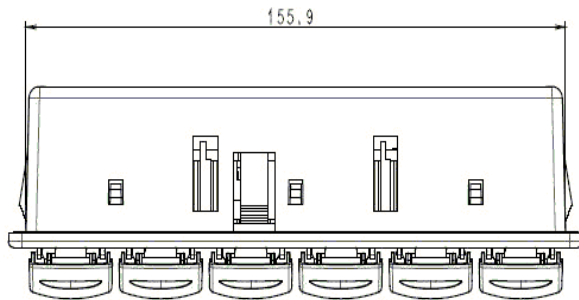
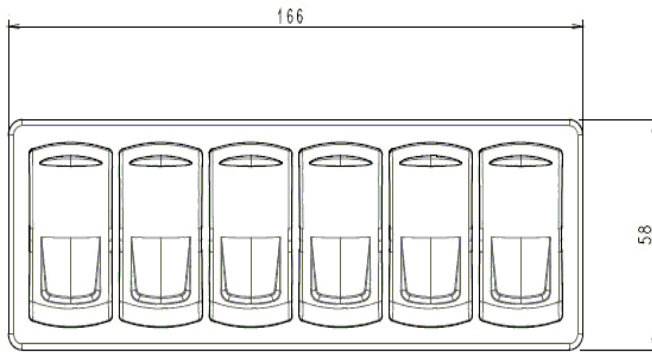
IV.3.2 Input labels :

IV.3.3 Output labels :

IV.4 MECHANICAL INTERFACES



IV.5 ELECTRICAL INTERFACES

IV.5.1 power supply

| Designation: | Value min | Value typ | Value max | Condition |
|---------------------------------|-----------|--------------|-----------|------------|
| +VBAT | +8V | +14V or +28V | +32V | |
| Normal mode current consumption | | | +500mA | |
| Sleep mode current consumption | - | - | 1.5mA | +VBAT =24V |
| Sleep mode current consumption | - | - | 1mA | +VBAT =12V |

IV.5.2 communication

IV.5.2.1 CAN interface

Complies with SAE J1939 communication protocole

| Designation: | Value min | Value typ | Value max | Condition |
|---|-----------|-----------|-----------|--|
| Recessive state on CAN H : | 2.0V | 2.5V | 3.0V | no load |
| Recessive state on CAN L | 2.0V | 2.5V | 3.0V | no load |
| Dominant state on CAN H | 2.75V | 3.5V | 4.5V | Load : 60 ohms between CAN H and CAN L |
| Dominant state on CAN L | 0.5V | 1.5V | 2.25V | Load : 60 ohms between CAN H and CAN L |
| Recessive state on differential voltage | -1.0V | - | 0.5V | no load |
| Dominant state on differential voltage | 1.5V | 2.0V | 3.0V | Load : 60 ohms between CAN H and CAN L |
| Bitrate | | 250 kbaud | | |

IV.5.2.2 CAN addressing lines

Four masters KS modules can be connected on the same CAN bus. To differentiate them, 2 addressing lines defines the KS modules number depending on their connection to ground:

| AD_CAN1 | AD_CAN0 | MASTER number |
|---------|---------|---------------|
| nc | nc | 1 |
| nc | GND | 2 |
| GND | nc | 3 |
| GND | GND | 4 |

where:

AD_CAN0, AD_CAN1: CAN addressing lines

nc: not connected

GND: connected to ground

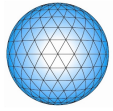

IV.5.2.3 LIN interface

| Designation: | Value min | Value typ | Value max | Condition |
|------------------------------|------------------|------------------|------------------|------------------|
| VLin DC Voltage on LIN Bus | +8V | +14V | +16V | |
| LIN recessive output voltage | +4.8V | - | - | |
| LIN dominant output voltage | - | - | 3.2V | |
| Bitrate | | 20 kbauds | | |

IV.5.2.4 LIN addressing lines

Up to 3 slaves KS modules can be connected to a master KS module.

There are 2 addressing lines which allows the slave software to determine its slave number as showed below:

| AD_LIN1 | AD_LIN0 | SLAVE number |
|----------------|----------------|---------------------|
| nc | nc | 1 |
| nc | GND | 2 |
| GND | nc | 3 |

where:

AD_LIN0, AD_LIN1: LIN addressing lines

nc: not connected

GND: connected to ground

IV.6 SOFTWARE INTERFACES

IV.6.1 Input status frame

The input status frame is transmitted by the master KS module with the appropriate proprietary frame identifier:

| MASTER number | Input Status Frame Identifier |
|---------------|-------------------------------|
| 1 | 0x18FF19AE |
| 2 | 0x18FF1AAE |
| 3 | 0x18FF1BAE |
| 4 | 0x18FF1CAE |

The frame cycle is specified to 1s or upon input status change.

J1939 message format

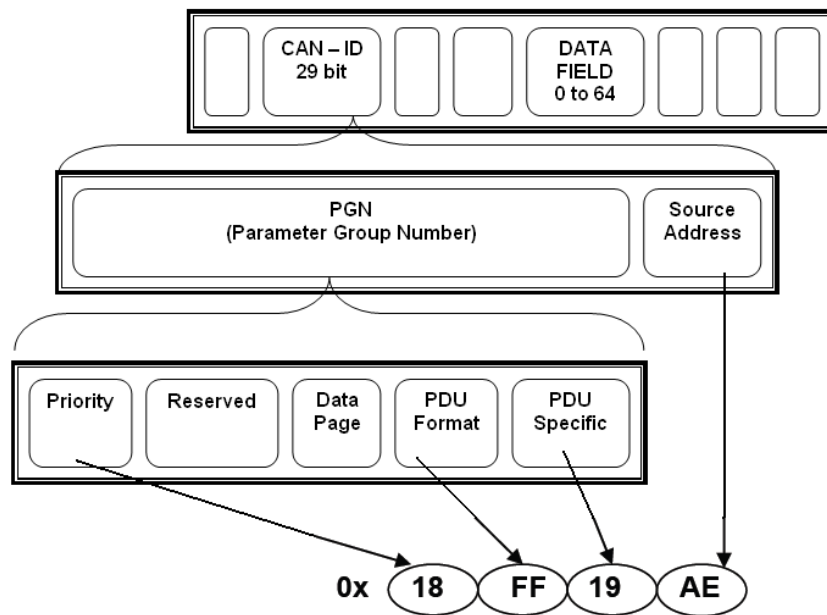

Input status frame for the Master Module Number 1

The frame contains the following information spreads on 8 data bytes:

| Byte | Bit 7 | Bit 6 | Bit 5 | Bit 4 | Bit 3 | Bit 2 | Bit 1 | Bit 0 |
|------|----------|-----------|-----------|-----------|----------|----------|----------|---------|
| 1 | M_IN7 | M_IN6 | M_IN5 | M_IN4 | M_IN3 | M_IN2 | M_IN1 | M_IN0 |
| 2 | S1_IN3 | S1_IN2 | S1_IN1 | S1_IN0 | M_IN11 | M_IN10 | M_IN9 | M_IN8 |
| 3 | S1_IN11 | S1_IN10 | S1_IN9 | S1_IN8 | S1_IN7 | S1_IN6 | S1_IN5 | S1_IN4 |
| 4 | S2_IN7 | S2_IN6 | S2_IN5 | S2_IN4 | S2_IN3 | S2_IN2 | S2_IN1 | S2_IN0 |
| 5 | S3_IN3 | S3_IN2 | S3_IN1 | S3_IN0 | S2_IN11 | S2_IN10 | S2_IN9 | S2_IN8 |
| 6 | S3_IN11 | S3_IN10 | S3_IN9 | S3_IN8 | S3_IN7 | S3_IN6 | S3_IN5 | S3_IN4 |
| 7 | WKO_IN11 | WKO_IN9 | WKO_IN7 | WKO_IN5 | WKO_IN3 | WKO_IN1 | WKO_SWP | |
| 8 | not used | S3_LINErr | S2_LINErr | S1_LINErr | not used | not used | not used | WKO_CAN |

'1' = Active.

'0' = Inactive.

where:

M_IN0 to 11: Master SWP input status

S1_IN0 to 11: Slave SWP#1 input status

S2_IN0 to 11: Slave SWP#2 input status

S3_IN0 to 11: Slave SWP#3 input status

WKO_SWP: SWP related to the wake up origin information

WKO_SWP = 0 : Master SWP

WKO_SWP = 1 : Slave SWP 1

WKO_SWP = 2 : Slave SWP 2

WKO_SWP = 3 : Slave SWP 3

WKO_IN1 to 11: wake-up input status at wake-up of the SWP indicated by WKO_SWP

WKO_CAN : CAN wake-up origin

S1_LINErr: Slave SWP#1 LIN error

S2_LINErr: Slave SWP#2 LIN error

S3_LINErr: Slave SWP#3 LIN error

See §IV.3.2 for input physical location.

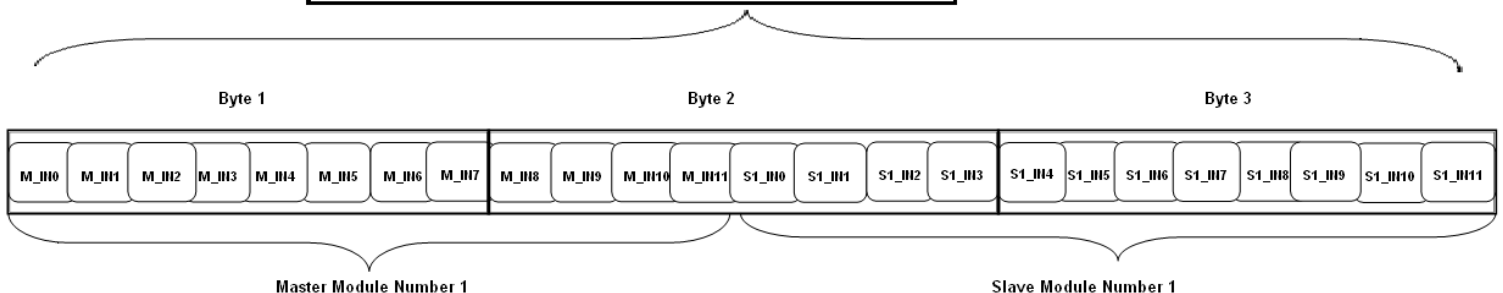
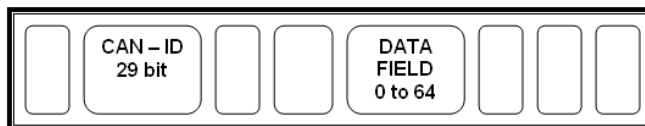

IV.6.2 Output Commands frame

The output commands frame is received by the master KS module with the appropriate proprietary frame identifier:

| MASTER number | Output Command Frame Identifier |
|---------------|---------------------------------|
| 1 | 0x18FF29xx |
| 2 | 0x18FF2Axx |
| 3 | 0x18FF2Bxx |
| 4 | 0x18FF2Cxx |

Where xx is the Source Address (SA) of the transmitting unit.
The frame cycle is specified at 50ms.

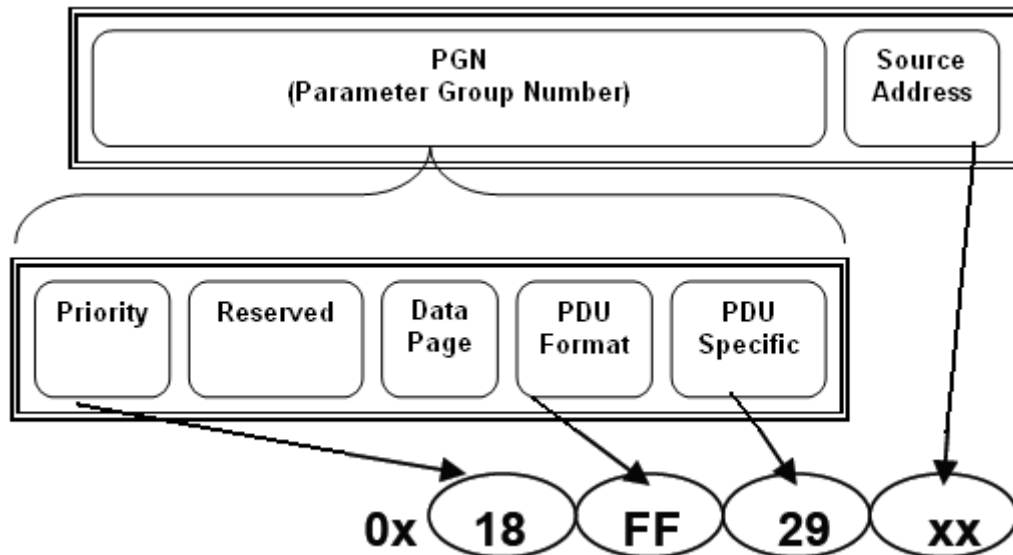

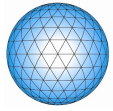

The frame contains the master and the slave KS module output commands spread on 8 data byte as defined below:

| Byte | Bit 7 | Bit 6 | Bit 5 | Bit 4 | Bit 3 | Bit 2 | Bit 1 | Bit 0 |
|------|---------------------------------------|-----------------|-----------------|-----------------|----------|-----------------|-----------------|-----------------|
| 1 | M_OUT7 | M_OUT6 | M_OUT5 | M_OUT4 | M_OUT3 | M_OUT2 | M_OUT1 | M_OUT0 |
| 2 | S1_OUT3 | S1_OUT2 | S1_OUT1 | S1_OUT0 | M_OUT11 | M_OUT10 | M_OUT9 | M_OUT8 |
| 3 | S1_OUT11 | S1_OUT10 | S1_OUT9 | S1_OUT8 | S1_OUT7 | S1_OUT6 | S1_OUT5 | S1_OUT4 |
| 4 | S2_OUT7 | S2_OUT6 | S2_OUT5 | S2_OUT4 | S2_OUT3 | S2_OUT2 | S2_OUT1 | S2_OUT0 |
| 5 | S3_OUT3 | S3_OUT2 | S3_OUT1 | S3_OUT0 | S2_OUT11 | S2_OUT10 | S2_OUT9 | S2_OUT8 |
| 6 | S3_OUT11 | S3_OUT10 | S3_OUT9 | S3_OUT8 | S3_OUT7 | S3_OUT6 | S3_OUT5 | S3_OUT4 |
| 7 | Cab Illumination (1% / bit, 0 offset) | | | | | | | |
| 8 | SLEEP | <i>not used</i> | <i>not used</i> | <i>not used</i> | BKL | <i>not used</i> | <i>not used</i> | <i>not used</i> |

Output symbol description:

- M_OUT0 to 11: Master SWP output commands
- S1_OUT0 to 11: Slave SWP#1 output commands
- S2_OUT0 to 11: Slave SWP#2 output commands
- S3_OUT0 to 11: Slave SWP#3 output commands

Cab Illumination: output PWM ratio for backlight

Resolution: 1% / bit, 0 offset

| Binary | Decimal | Resolution |
|-----------------|---------|------------|
| 0 0 0 0 0 0 0 0 | 0 | 0% |
| 0 0 0 0 0 0 0 1 | 1 | 1% |
| 0 0 0 0 0 0 1 0 | 2 | 2% |
| ... | | |

Range: 0-99%

BKL: Backlight command

0: Backlight not activated

1: Backlight activated

SLEEP: Sleep command

See §IV.3.3 for output physical location.

IV.7 PIN ALLOCATION

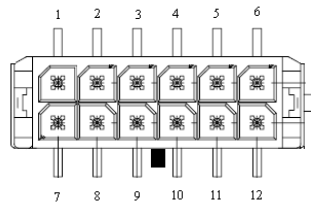

IV.7.1 Master connector

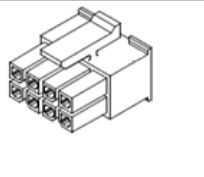
| CN100 : | | |
|---|------------------|--|
| Part number: | Molex 43045-1218 | |
| Pins quantity : | 12 | |
| Harness connector : | Molex 43025-1200 | |
| Pins reference : | Molex 43030-0007 | |
|  | | |
| Signal name | pin | Function |
| GND | 1 | Ground |
| +VBAT | 2 | Battery voltage |
| CAN_ADR0 | 3 | CAN adresse line 0 |
| CAN_ADR1 | 4 | CAN Adresse line 1 |
| CAN_H | 5 | CAN signal H |
| CAN_L | 6 | CAN signal L |
| GND | 7 | Ground (to connect another KS module) |
| +VBAT | 8 | Battery voltage (to connect another KS module) |
| LIN | 9 | LIN signal |
| Wake up Line | 10 | Wake up line |
| NC | 11 | Not connected |
| TERM_CAN_L | 12 | 120 resistor between CAN H and CAN L if pin connected to CAN_L |

IV.7.2 Slave connector

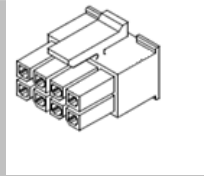
| CN100 : | | |
|---|------------------|--|
| Part number: | Molex 43045-1218 | |
| Pins quantity : | 12 | |
| Harness connector : | Molex 43025-1200 | |
| Pins reference : | Molex 43030-0007 | |
|  | | |
| Signal name | pin | Function |
| GND | 1 | Ground |
| +VBAT | 2 | Battery voltage |
| LIN_ADR0 | 3 | LIN adresse line 0 |
| LIN_ADR1 | 4 | LIN Adresse line 1 |
| NC | 5 | Not connected |
| NC | 6 | Not connected |
| GND | 7 | Ground (to connect another KS module) |
| +VBAT | 8 | Battery voltage (to connect another KS module) |
| LIN | 9 | LIN signal |
| Wake up Line | 10 | Wake up line |
| LIN | 11 | LIN signal |
| Wake up Line | 12 | Wake up line |

IV.8 CABLES

The maximum length of the cable (0.5 mm² multi-wire) between the master module and the farthest slave module is 5 meters.

RESPONSE TIME DELAY

- The time delay between a switch status change and the associated CAN frame emission is less than 100 ms.
- The time delay between a CAN frame reception with a LED status change and the associated LED command is less than 100 ms.

WAKE UP FUNCTION

- There are two different ways to wake up the KS system: an activity on the CAN line or a switch associated to a wake up function in 'ON' position.
- The bottom position of switch 1, 2, 3 and 4 of the master module can be associated to a wake-up function (optional).

IV.9 ENVIRONMENT CHARACTERISTICS

IV.9.1 EMC tests

| EMC tests | Standard | Level |
|------------------------------|------------|--|
| Pulse on power supply lines | ISO7637-2 | Pulse 1: -450V; Ri=50Ω; td=1ms, t1=1s Pulse 2a: +50V; Ri=2Ω; td=0.05ms, t1=1s Pulse 2b: +20V; Ri=0.05Ω; td=0.5s, Pulse 3a,3b: ± 200V; Ri=50Ω; td=0.1μs, pulse 4 : Vs= - 16V; Va = -12V; t6 = 100 ms; t8 = 10s Pulse 5a: +58V; Ri=1.5Ω; td=480ms |
| Pulse on signal supply lines | ISO 7637-3 | Pulses a and b: ± 200V |
| ESD | ISO10605 | Direct discharges on the connector pins through 2 kV and 330 pF: ± 2 kV Air discharges: ± 8 kV Contact discharges: ± 4 kV |
| Conducted immunity BCI | ISO11452-4 | 100mA Class A 200mA Class C |
| Radiated immunity | ISO11452-2 | 100V/m 200MHz to 2GHz |
| Radiated emission | CISPR25 | Class 3 |
| e marking | 2006/28/CE | KS module modules are compliant with e marking 2006/28/CE standard |

IV.9.2 Mechanical tests

| Mechanical tests | Standard | Level |
|----------------------|----------------------|--|
| Sinusoidal vibration | CEI 68-2-6, test Fc | Band [5 Hz, 27.3 Hz], with +/- 1 mm displacement Band [27.3 Hz, 100 Hz], with 3G acceleration, 1 octave/min, Test duration: 20 hours power off on the 3 axes |
| Random vibration | CEI 68-2-64 test Fda | Acceleration: 0.02g ² /Hz between 5Hz à 100Hz. Sweep : 1 octave /minute. Test duration 20 h on each axes : power ON |
| Protection index | EN 60529 | - Protection index for front side area : IP30 |
| Shocks | CEI 68-2-27 test Ea | The system must withstand 50g during 11ms (½ sinus), 3 shocks on each axes in the directions (total of 18 shocks) The instrument is power off during the test. |
| Salt mist | CEI 68-2-52 | Test duration : 10 hours Solution 5% sodium chloride (NaCl) |
| Chemical substances | ISO16750-5 | The following tests are performed according to the ISO16750-5 : 2004 standard : Battery fluide, cafeine and sugar, fuel diesel, IPA 70% (brush) Interior cleaner and galss cleaner (spray) After chemical substance exposure all products are exposed at +70°C during 96 hours. |

IV.9.3 Climatics tests

| Climatic tests | Standard | Level |
|-----------------------------|-------------------------|--|
| Dry heat | CEI 600 68-2-2 | 70°C during 72 hours |
| Cold | CEI 600 68-2-1 | -40°C during 72 hours |
| Damp heat | CEI 600 68-2-30 | Test duration : 10 cycles described hereafter : |
| Slow temperature variation | CEI 600 68-2-14 test Nb | Test duration : 8 cycles described hereafter with : t1 = 3h TA=-40°C TB=+70°C |
| Quick temperature variation | CEI 600 68-2-14 test Na | Instrument power OFF 10 cycles (t1 = 1H ; t2 < 3 min ; TA=-40°C ; TB=+70°C) |

IV.10 MASTER FULL EQUIPPED

The master full equipped variant is defined by the table below:

IV.10.1 Function description

| Function | Quantity | Description |
|-----------|----------|---------------------|
| CAN | 1 | J1939 |
| LIN | 1 | LIN 2.0 |
| Wake up * | 3 | CAN, KS n°1, KS n°6 |

IV.10.2 Switch description

| KS (See §V) | Function |
|-------------|-------------|
| 1 | 3 Positions |
| 2 | 3 Positions |
| 3 | 3 Positions |
| 4 | 3 Positions |
| 5 | 3 Positions |
| 6 | 3 Positions |

IV.10.3 LED description

| LED/ KS | KS1 | KS2 | KS3 | KS4 | KS5 | KS6 |
|------------|--------|--------|--------|--------|--------|--------|
| Top Led | Yellow | Yellow | Yellow | Yellow | Yellow | Yellow |
| Bottom Led | Yellow | Yellow | Yellow | Yellow | Yellow | Yellow |

* Wake up event = bottom position

IV.11 SLAVE FULL EQUIPPED

The slave full equipped variant is defined by the table below:

IV.11.1 Function description

| Function | Quantity | Description |
|----------|----------|-------------|
| CAN | 0 | NA |
| LIN | 1 | LIN 2.0 |
| Wake up | 0 | NA |

IV.11.2 Switch description

| KS | Function |
|----|-------------|
| 1 | 3 Positions |
| 2 | 3 Positions |
| 3 | 3 Positions |
| 4 | 3 Positions |
| 5 | 3 Positions |
| 6 | 3 Positions |

IV.11.3 LED description

| LED/KS | KS1 | KS2 | KS3 | KS4 | KS5 | KS6 |
|------------|--------|--------|--------|--------|--------|--------|
| Top Led | Yellow | Yellow | Yellow | Yellow | Yellow | Yellow |
| Bottom Led | Yellow | Yellow | Yellow | Yellow | Yellow | Yellow |

IV.12 MASTER LIGHT

The master light variant is defined by the table below:

IV.12.1 Function description

| Function | Quantity | Description |
|-----------|----------|---------------------|
| CAN | 1 | J1939 |
| LIN | 1 | LIN 2.0 |
| Wake up * | 3 | CAN, KS n°1, KS n°6 |

IV.12.2 Switch description

| KS | Function |
|----|-------------|
| 1 | 3 Positions |
| 2 | 3 Positions |
| 3 | 2 Positions |
| 4 | 2 Positions |
| 5 | 2 Positions |
| 6 | 2 Positions |

IV.12.3 LED description

| LED/ KS | KS1 | KS2 | KS3 | KS4 | KS5 | KS6 |
|------------|--------|--------|--------|--------|--------|--------|
| Top Led | Yellow | Yellow | X | X | X | X |
| Bottom Led | Yellow | Yellow | Yellow | Yellow | Yellow | Yellow |

* Wake up event = bottom position

IV.13 SLAVE LIGHT

The slave light variant is defined by the table below:

IV.13.1 Function description

| Function | Quantity | Description |
|----------|----------|-------------|
| CAN | 0 | NA |
| LIN | 1 | LIN 2.0 |
| Wake up | 0 | NA |

IV.13.2 Switch description

| KS | Function |
|----|-------------|
| 1 | 3 Positions |
| 2 | 3 Positions |
| 3 | 2 Positions |
| 4 | 2 Positions |
| 5 | 2 Positions |
| 6 | 2 Positions |

IV.13.3 LED description

| LED/KS | KS1 | KS2 | KS3 | KS4 | KS5 | KS6 |
|------------|--------|--------|--------|--------|--------|--------|
| Top Led | Yellow | Yellow | X | X | X | X |
| Bottom Led | Yellow | Yellow | Yellow | Yellow | Yellow | Yellow |

IV.14 SELECTION GUIDE

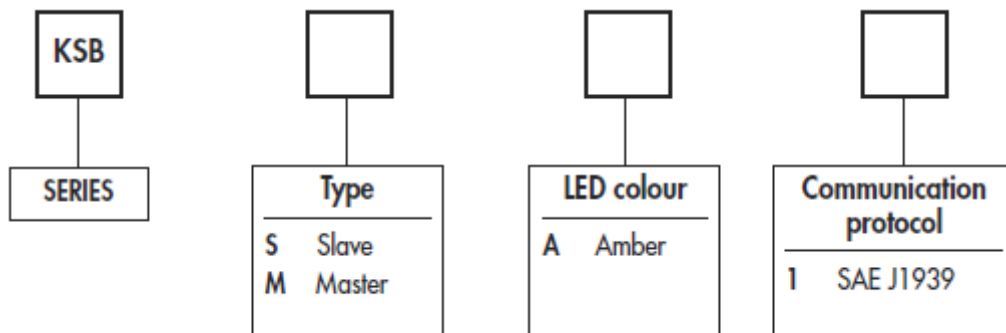

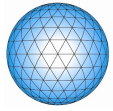

IV.15 ACCESSORIES

IV.15.1 Hole plug

Usefull for future extensions.

| Code | Colour |
|---------|-----------|
| U2271 | Blue |
| U2271/4 | Dark blue |
| U2272 | Black |
| U2273 | Green |

| Code | Colour |
|-------|--------|
| U2274 | Grey |
| U2275 | Yellow |
| U2276 | Red |
| U2277 | Ivory |

| Code | Colour |
|-------|--------|
| U2279 | Orange |

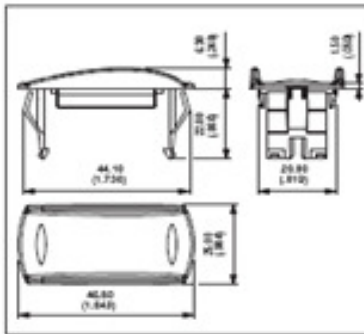

Recommended panel thickness :
1,50 mm to 6 mm

IV.15.2 Actuator Removing Tool



2 tools are supplied

EXTRACT ACTUATOR

Allows the extraction of the rocker / rocker support assembly.
Place the 2 claws under the support and push as indicated by the arrow.

EXTRACT ROCKER

Allows to separate the rocker from its support.
Insert the tool between rocker and support as indicated by the arrow. Pull out the tool in the opposite direction.

EXTRACT SWITCH

Allows to extract switch from panel mounting units. 2 tools are necessary.
Insert the tools between switch and panel mounting units from the rear to compress the snap-in device. Pull off switch manually.

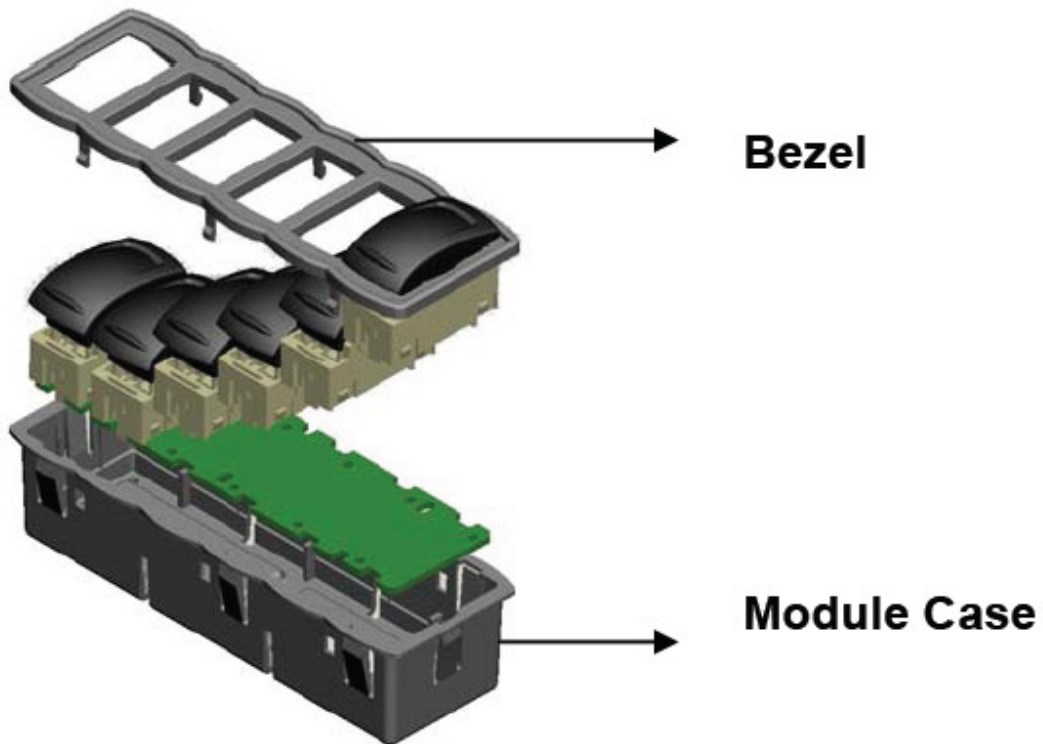

IV.15.3 Bezel

| Code | Colour |
|-------|--------|
| U6802 | black |
| U680x | ... |

IV.15.4 Module Case

| Code | Colour |
|-------|--------|
| U6742 | black |
| U674x | ... |