

目录 (二) CONTENTS

可转位铣削刀具 页码提示

可转位铣削刀具一览表
INDEXABLE MILLING TOOLS OVERVIEW P104~P108

可转位铣削刀具命名规则
INDEXABLE MILLING TOOLS CODE KEY P109~P110

可转位铣削刀片命名规则
INDEXABLE MILLING INSERTS CODE KEY P111~P112

可转位铣削刀具系列
INDEXABLE MILLING TOOLS P113~P236

面铣刀系列
FACE MILLING TOOLS P113~P164

方肩台阶铣刀系列
S SQUARE-SHOULDER MILLING TOOLS P165~P186

仿形铣刀系列
PROFILE MILLING TOOLS P187~P193

三面刃铣刀系列
SIDE AND FACE MILLING TOOLS P194~P214

倒角铣刀系列
CHAMFER MILLING TOOLS P215~P217

特殊铣刀 (大进给) 系列
HIGH FEED MILLING CUTTER P218~P229

螺旋立铣刀系列
HELICAL END FACE MILLING TOOLS P230~P231

立铣刀/壳形铣刀
END MILL/FACE MILL P232~P236

目录 (三) CONTENTS

孔加工刀具 页码提示

可转位浅孔钻系列
INDEXABLE U DRILL P237~P252

镗削刀具系列
BORING TOOLS P253~P279

铣削刀具 | MILLING TOOLS

可转位铣削刀具 Indexable milling tools

Category 类别	Shape 形状	Feature 特征	Category 类别	Shape 形状	Feature 特征
面 铣 刀	Kr:45° AF01 	大前角设计, 切削轻快 刀片槽型多样, 应用广 配合修光, 良好表面质 量 参考: SE□T 12T3	面 铣 刀	Kr:45° AF02 	大前角设计, 切削轻快 刀片槽型多样, 应用广 梳齿设计, 震动平衡小 参考: SE□T 12T3
	Kr:45° AF03 	压板式固定, 装卸简单 高硬度合金刀垫, 抗冲 击强。 参考: SE□N 1203 (Zccct) SE□N 1504 (Zccct)		Kr:45° AF04 	8刃口经济型刀片螺钉 压紧, 精度高作用广 泛 参考: OFKT 05T3(Zccct)
	Kr:45° AF04 	8刃口经济型刀片压块 压紧, 装卸刀片简单轴 向可调节。 参考: OFKR07 (Zccct)		Kr:45° AF05 	8刃口经济型刀片螺钉 压紧, 精度高作用广 泛 参考: OD□□ 0605(瓦尔特)
	Kr:45° AF06 	16刃负角刀片, 经济性 能好, 抗冲击能力强。 参考: ON□□ 0604□□ (Zccct) ON□□ 08T5□□ (Zccct)		Kr:45° AF08 	8刃负角刀片, 经济性 能好切削阻力小, 轻快 参考: SNEK 1206ANN(克洛伊)
	Kr:45° AF09 	8刃负角刀片, 经济性 能好, 刃口抗冲击强。 参考: SNMX 1205XTN(特固克)		Kr:45° AF10 	10刃负角刀片, 高经济 性能螺旋型构造, 阻力 小, 双切结构, 强度高 参考: PNMU 1205ANER(京瓷)
	Kr:45° AF11 	14刃负角刀片, 经济性 能好, 切削阻力小, 轻快。 参考: XNMX 070508		Kr:45° AF12 	8刃负角刀片, 丰富的 槽型可满足不同工况 的高效加工。 参考: SNGX 1205ANN
	Kr:55° DF01 	12刃负角刀片, 高经济 性能, 压块压紧, 装卸 刀片简单。 参考: HNEX 0905 (Zccct)		Kr:67° DF01 	10刃负角刀片, 高经济 性能螺旋型构造, 阻力 小, 双切结构, 强度高。 参考: PNEG 110512R (Zccct)
	Kr:60° DF02 	双正前角, 低切削力 立装刀片, 大切重载加 工, 装夹简单。 参考: LNKT 2510 (Zccct)		Kr:65° DF03 	8刃负角刀片, 经济性 能好, 切削平衡, 阻力 小, 铸铁和钢的优良选择。 参考: R365-1505ZNE (山特)
	Kr:75° EF02 	双正前角, 低切削力 立装刀片, 大切重载加 工, 装夹简单。 参考: LNKT 1506 (Zccct)		Kr:75° EF03 	压板式固定, 装卸简单 高硬度合金刀垫, 抗冲 击强。 参考: SPKN 1203 (Zccct) SPKN 1504 (Zccct)

类别	Shape 形状	Feature 特征	Category 类别	Shape 形状	Feature 特征
面铣刀	Kr:75° EF04 	通用性强刀片槽型多, 适用广 参考: SPK□ 1204 (Zccct)	面铣刀	Kr:75° EF06 	重切削切深大, 大幅提高了单位时间内切削排出量 参考: SPMT 1806 EDER (京瓷)
	Kr:75° EF08 	8刃负角刀片, 丰富的槽型可满足不同工况的高效加工 参考: SNGX1205ENN		Kr:88° PF88 	8刃负角刀片, 丰富的槽型可满足不同工况的高效加工 参考: SNGX1205PNN
	Kr:90° PF01 	结构简单, 装卸刀片快捷, 经济适用性好 参考: TPKN 2204 (Zccct)		Kr:90° PF02 	疏, 密, 超密齿设计, 获得良好的工件表面质量, 适用于精, 半精和粗加工 参考: SEET 09T308PER (Zccct) SEET 120308PER (Zccct)
	Kr:90° PF03 	双正前角, 低切削力立装刀片, 大切重加工, 装夹简单 参考: LNKT 1506EN-ZR (Zccct) LNKT 2007DN-ZR (Zccct) LNKT 2510-ZR (Zccct)		Kr:90° PF04 	疏, 密, 超密齿设计, 获得良好的工件表面质量, 适用于精, 半精和粗加工 参考: R290-12T308 (山特)
	Kr:90° PF06 	4刃角刀片, 经济性好大前角设计, 低切削力高精度, 装卸简单 参考: SOMT 12T308PEER (三菱)		Kr:90° PF07 	4刃角刀片, 经济性好切刃锋利, 阻力小轴向抗力小 参考: XDMT 120408PDER (住友)
	Kr:90° PF08 	4角立装刀片, 装卸简单, 切削锋利, 刀尖强度高, 切削稳定 参考: LNMX170808 PNSR (住友)		Kr:90° PF09 	6刃负角刀片, 经济性能好刃口抗冲击强大前角设计, 切削锋利 参考: XNEX 0806 (山高)
	Kr:90° PF10 	低阻力的良好切削效果, 大前角确保低阻力, 抗振刀能力强, 厚规格设计抗崩损性卓越 参考: WNMU080608 (京瓷)		Kr:90° PF11 	6刃负角刀片, 经济性能好刃口冲击强, 大前角设计抗震能力强。 参考: XNGU090508PRHDE(特固克)
	Kr:R RF01 	极强的切削刃口螺钉压紧, 装卸简单经济性好 参考: RCKT 10T3MO-DR (Zccct) RCKT 1204MO-DR (Zccct) RCKT 1606MO-DR (Zccct) RCKT 2006MO-DR (Zccct)		Kr:R RF02 	极强的切削刃口螺钉压紧, 装卸简单经济性好 参考: RDKW 0803MO (Zccct) RDKW 10T3/1204MO (Zccct) RDKW 1204MO (Zccct) RDKW 1605MO (Zccct) RDKW 2006MO (Zccct)
	Kr:R RF03 	大前角设计, 切削阻力小, 锋利, 经济性好刀片装卸简单 参考: RPMT/W 1204 (三菱) RPMT1606 (三菱)		Kr:R RF04 	仿振刃形设计螺钉压紧, 简单稳定 参考: QPMT 1204MO (住友)

Category 类别	Shape 形状	Feature 特征	Category 类别	Shape 形状	Feature 特征
方肩台阶铣刀	Kr:90° PE01 	带修光刃, 三维螺旋刃, 切削阻力小 参考: APKT 11T3□□ (Zccct) APKT 1604□□ (Zccct)	方肩台阶铣刀	Kr:90° PE01 	带修光刃, 三维螺旋刃, 切削阻力小 参考: APKT 11T3□□ (Zccct) APKT 1604□□ (Zccct)
	Kr:90° PE02 	正螺旋, 排屑好密齿型结构, 加工效率高 参考: APKT 11T3□□ (Zccct)		Kr:90° PE02 	正螺旋, 排屑好密齿型 参考: APKT 11T3□□ (Zccct)
	Kr:90° PE03 	底刃过中心, 可直接钻孔加工 参考: APMT 113504PDER (Zccct) APMT 160408PDER (Zccct)		Kr:90° PE04 	刃口抗冲击力强, 切削阻力小, 耐用性高 参考: LD□□ 1504 (森拉天时)
	Kr:90° PE05 	带修光刃, 三维螺旋刃, 切削阻力小, 抗冲击能力强 参考: APKT 1705PER (特固克)		Kr:90° PE05 	带修光刃, 三维螺旋刃, 切削阻力小, 抗冲击能力强 参考: APKT 1705PER (特固克)
	Kr:90° PE06 	独有的曲线状切刃, 提高刀尖强度, 切削阻力低, 良好的90°, 适用于精加工 参考: AXMT 1235□□PEER (住友) AXMT 1705□□PEER (住友)		Kr:90° PE06 	大前角设计, 切削轻快独特的曲线状切刃, 提高刀尖强度, 切削阻力低, 良好的90°, 适用于精加工 参考: AXMT 1235□□PEER (住友) AXMT 1705□□PEER (住友)
	Kr:90° PE07 	底刃过中心, 可直接钻孔加工 参考: APMT 1035PDER (住友) APMT 1605PDER (住友)		Kr:90° PE08 	三维曲线状切刃, 提高刀尖强度, 切削阻力低, 良好的90°, 适用于精加工 参考: ADMT 080304R (瓦尔特) ADMT 120408R (瓦尔特) ADMT 160608R (瓦尔特)
	Kr:90° PE08 	三维曲线状切刃, 提高刀尖强度, 切削阻力低, 良好的90°, 适用于精加工 参考: ADMT 080304R (瓦尔特) ADMT 120408R (瓦尔特) ADMT 160608R (瓦尔特)		Kr:90° PE09 	三角度好低切削力 参考: R390-11T3□□ (山特) R390-1704□□ (山特)
	Kr:90° PE09 	三角度好低切削力, 良好的90°, 适用于精加工 参考: R390-11T3□□ (山特) R390-1704□□ (山特)		Kr:90° PE10 	直角度好, 大前角设计, 低切削力适用于精加工 参考: APKT 100304PDER (伊斯卡)
	Kr:90° PE10 	直角度好低切削力 参考: BDMT 11T3□□ER (京瓷) BDMT 1704□□ER (京瓷)		Kr:90° PE11 	

Category 类别	Shape 形状	Feature 特征	Category 类别	Shape 形状	Feature 特征
方肩台阶铣刀	Kr:90° PE12 	4刃负角刀片, 经济性能好, 抗冲击强 参考: LN□X151008PNR (克洛伊)		Kr:90° PE14 	三维曲线状态刃, 切削阻力低, 适用于精加工。 参考: AXMT11T308 (Zccct, 三特)

Category 类别	Shape 形状	Feature 特征	Category 类别	Shape 形状	Feature 特征
仿形铣刀	Kr:R RB01 	适合大型模具的粗加工, 圆弧刃采用三面刃, 经济性好 参考: ZDET 08T2 (Zccct) ZDET 1103 (Zccct) ZDET 13T3 (Zccct) ZPNT 2204 (Zccct)	仿形铣刀	Kr:R RB02 	适合模具的粗加工, 采用三维复杂的槽型, 圆弧精度高, 抗振性好 参考: XPHT 16/20/25/30/32R803 (Zccct)
	Kr:R RB03 	刀具精度高, 用于仿形精加工, 安装精度高, 稳定性好 参考: ZOHX1203/1604/2005/2506/3007/3207 (Zccct)		Kr:R RB04 	大前角设计, 切削阻力小, 切削刃强度高, 防偏转结构, 波浪刃型 参考: ZNMT 1804100-C (住友) ZNMT 2205125-C (住友) ZNMT 2706150-C (住友)

Category 类别	Shape 形状	Feature 特征	Category 类别	Shape 形状	Feature 特征
三面刃铣刀	Kr:R PT01 	抗冲击力强, 切削阻力小 参考: MPHT 060304-DM (Zccct) MPHT 080305-DM (Zccct) MPHT 120408-DM (Zccct)	三面刃铣刀	Kr:R PT01 	抗冲击力强, 切削阻力小 参考: MPHT 060304-DM (Zccct) MPHT 080305-DM (Zccct) MPHT 120408-DM (Zccct)
	Kr:90° PT01 	抗冲击力强, 切削阻力小 参考: MPHT 060304-DM (Zccct) MPHT 080305-DM (Zccct) MPHT 120408-DM (Zccct)		Kr:90° PT02 	切削锋利, 浅槽加工, 4刃, 经济性好 参考: XSEQ 1202/1203 (Zccct) /12T3/1204/12T4 (Zccct)
	Kr:90° PT02 	切削锋利, 浅槽加工, 4刃, 经济性好 参考: XSEQ 1202/1203 (Zccct) /12T3/1204/12T4 (Zccct)		Kr:90° PT03 	刀片立装结构抗冲击性能优良, 切削更轻快。 参考: AXMT11T308 (Zccct, 三特)
	Kr:90° PT04 	切削锋利, 浅槽加工, 4刃, 经济性好 参考: LNET102304/2804/3304-GM (Zccct) LNET123804/4304/4804/5304-GM (Zccct)		Kr:90° PT04 	刀片立装结构抗冲击性能优良, 切削更轻快。 参考: LNET102304/2804/3304-GM (Zccct) LNET123804/4304/4804/5304-GM (Zccct)
	Kr:90° PT05 	刀片立装结构抗冲击性能优良, 加工槽底表面质量好。 参考: LNGX1005□□-GM (Zccct) LNGX1407□□-GM (Zccct)		Kr:90° PT05 	刀片立装结构抗冲击性能优良, 加工槽底表面质量好。 参考: LNGX1005□□-GM (Zccct) LNGX1407□□-GM (Zccct)

Category 类别	Shape 形状	Feature 特征	Category 类别	Shape 形状	Feature 特征
倒角铣刀	Kr:45° AC01 	小平面倒角, 孔倒角, 铣削倒角 参考: SPMT 120408 (Zccct)	倒角铣刀	Kr:60° DC01 	小平面倒角, 孔倒角, 铣削倒角 参考: SPMT 120408 (Zccct)
	Kr:30° ZC01 	小平面倒角, 孔倒角, 铣削倒角 参考: SPMT 120408 (Zccct)	模具铣刀盘杆		市场通用产品, 性价比高。

Category 类别	Shape 形状	Feature 特征	Category 类别	Shape 形状	Feature 特征
大进给铣刀	Kr:x XK01 	有效分解径向切削力, 大进给切削, 用于插铣加工, 双重压紧, 牢固可靠 参考: SDMT 09T3 (Zccct) SDMT 1204 (Zccct)	大进给铣刀	Kr:x XK01 	有效分解径向切削力, 大进给切削, 用于插铣加工, 双重压紧, 牢固可靠 参考: SDMT 09T3-DM (Zccct) SDMT 1204 (Zccct)
	Kr:x XK02 	有效分解径向切削力, 大进给切削, 用于插铣加工, 双重压紧, 牢固可靠 参考: WPGT 05/06/08/09 (Zccct)		Kr:x XK02 	有效分解径向切削力, 大进给切削, 用于插铣加工, 双重压紧, 牢固可靠 参考: WPGT 060415ZSR (Zccct) WPGT 080615ZSR (Zccct) WPGT 090725ZSR (Zccct)
	Kr:x XK03 	6刃负角刀片, 经济性能好 参考: WNMX 09T316NN-MM (克洛伊)		Kr:x XK03 	6刃负角刀片, 经济性能好 参考: WNMX 09T316NN-MM (克洛伊)
	Kr:x XK04 	6刃双面槽铣刀片适合高效率的大进给加工。 参考: WXMU080612RGM		Kr:x EXN 	高效率、低切削抗力, 具有高密度刀座的大进给铣刀。 参考: LNMT0303ZER
	Kr:x EXN 	高效率、低切削抗力, 具有高密度刀座的大进给铣刀。 参考: LNMT0303ZER		Kr:x TE90 	设计密度小, 双面四角可用, 抗冲击性能强, 经济高效。 参考: 4NKT060308

Category 类别	Shape 形状	Feature 特征	Category 类别	Shape 形状	Feature 特征
螺旋立铣刀	Kr:90° PH01 	震动小, 抗冲击强, 大切深, 合适粗加工的高效率 参考: APKT 150412 (Zccct) SPMT 120408 (Zccct)	螺旋立铣刀	Kr:90° PH01 	震动小, 抗冲击强, 大切深, 合适粗加工的高效率 参考: APKT 150412 (Zccct) SPMT 120408 (Zccct)

★ 可转位铣削刀具型号表示规则 Milling Tool Code Key

主偏角 Lead Angle	
A	45°
D	60°
E	75°
P	90°
Z	30°
R	圆形
X	特殊 Special

刀具类别 Type Of Tools	
F	面铣刀 Face milling tool
E	方肩台阶铣刀 Shoulder milling tool
B	仿型铣刀 Profile milling tool
T	槽铣刀 T slot milling tool
K	大给进铣刀 High feed milling cutter
C	倒角铣刀 Chamfer milling tool
H	螺旋立铣刀 Helical end face milling tool

切削刃长度(mm) Cutting Edge Length							
刀片 Insert 内接圆直径 Incircle diameter	刀片形状 Shape of blade						
	C	D	R	S	T	L	
5.556	—	—	—	—	09	—	
6.350	06	07	—	—	11	—	
9.525	09	11	09	09	16	—	
12.700	12	15	12	12	22	—	
15.875	16	19	15	15	27	—	
19.050	19	—	19	19	33	—	
25.400	25	—	25	25	44	25	

类别编号
Number Of Type

A **F** **01** **12**

套式结构 Shell Structure

A型接口 A Type Of Adapter		B型接口 B Type Of Adapter	
	GB5342-96规定的Ø50-Ø80 套式面铣刀 GB5342-96ofØ50-Ø80shell Facmilling Cutter		GB5342-96规定的Ø100-Ø160 套式面铣刀 GB5342-96ofØ100-Ø160shell Facmilling Cutter
C型接口 C Type Of Adapter		D型接口 D Type Of Adapter	
	GB5342-96规定的Ø200-Ø250 套式面铣刀		GB5342-96规定的Ø315及以上的 套式面铣刀

侧固式柄、直柄、莫氏锥柄等连接方式参阅工具系统部分技术资料 Side-locked Shank, Straight Shank, Morse Taper Shank

刀具安装部位结构(如下图) Tool Installation Position			
A	A型接口 A type of adapter	W	侧固式 Side-locked
B	B型接口 B type of adapter	T	可换头 Replaceable Head
C	C型接口 C type of adapter	MT	莫氏 Morse
D	D型接口 D type of adapter	BT	锥式 Taper
Z	直杆 Straight shank	J	键槽式 Spline

切削方向 (R: 右 Cutting Direction Right	L: 左 Left		面铣刀具 Face Milling Tool
	右 Right	左 Left	
刀具长度 Tool Length	S	短 short	铣刀杆 Cutter Arbor
	M	标准 Standard	
	L	加长 lengthening	
槽型宽度 Groove Width	H12		三面刃铣刀 Side And Face Milling Tool
最深加工 The deepest machining	104		螺旋立铣刀 Helical And Face Milling Tool

A22 **050** **04** **R**

刀具加工部分直径 ØD
Diameter

齿数(螺旋立铣刀为槽数)
Tooth

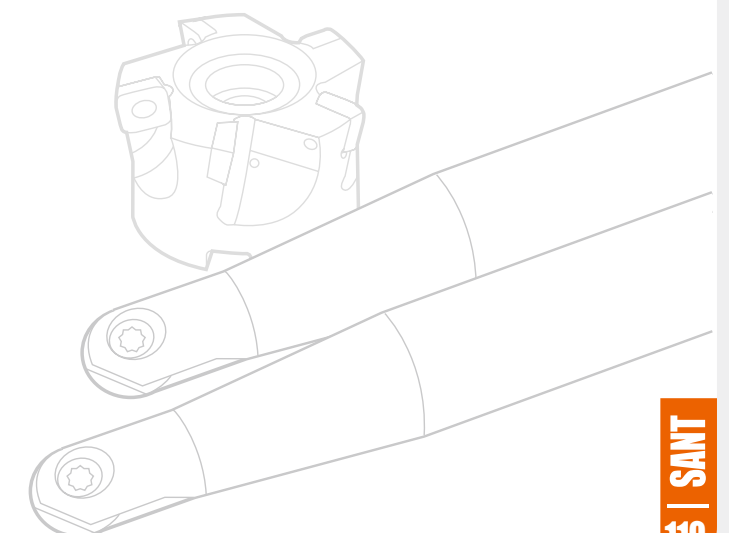
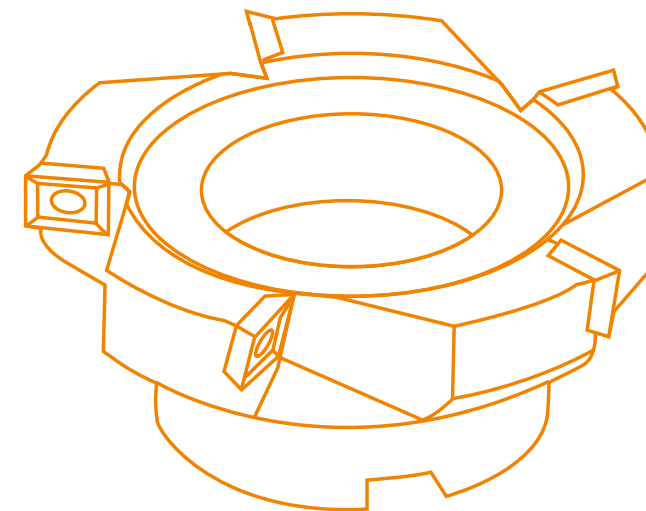

★ 可转位铣削刀片命名规则 Milling Insert Code Key

刀片形状 / 代号			公制							
形状代号			代号	有无孔	有无断屑槽	刀片剖面	代号	有无孔	有无断屑槽	刀片剖面
			B	有	无		N	无	无	
			H	有	单面		R	无	单面	
			C	有	无		F	无	双面	
			J	有	双面		A	有	无	
			W	有	无		M	有	单面	
	其他	Z	T	有	单面		G	有	双面	
			Q	有	无		X	---	---	特殊
			U	有	双面					

S P K N

主切削刃后角			
代号	后角(度)	代号	后角(度)
A	3°	B	5°
C	7°	D	15°
E	20°	F	25°
G	30°	N	0°
P	11°	O	其他的后角

公差										
代号	刀尖高度m公差(mm)	内接圆ØD1公差(mm)	厚度S1公差(mm)	(参考) M级精度详细情况 (按形状、大小分)						
				● 刀尖高度公差 (mm)						
				内接圆	正三角形	正方形	80°菱形	55°菱形	35°菱形	圆形
A	±0.005	±0.025	±0.025	6.35	±0.08	±0.08	±0.08	±0.11	±0.16	---
F	±0.005	±0.013	±0.025	9.525	±0.08	±0.08	±0.08	±0.11	±0.16	---
C	±0.013	±0.025	±0.025	12.7	±0.13	±0.13	±0.13	±0.15	---	---
H	±0.013	±0.013	±0.025	15.875	±0.15	±0.15	±0.15	±0.18	---	---
E	±0.025	±0.025	±0.025	19.05	±0.15	±0.15	±0.15	±0.18	---	---
G	±0.025	±0.025	±0.13	25.4	---	±0.18	---	---	---	---
J	±0.005	±0.05±0.13	±0.025	● 内接圆ØD1公差(mm)						
K	±0.013	±0.05±0.13	±0.025	内接圆	正三角形	正方形	80°菱形	55°菱形	35°菱形	圆形
L	±0.025	±0.05±0.13	±0.025	6.35	±0.05	±0.05	±0.05	±0.05	±0.05	---
M	±0.08±0.18	±0.05±0.13	±0.13	9.525	±0.05	±0.05	±0.05	±0.05	±0.05	±0.05
N	±0.08±0.18	±0.05±0.13	±0.025	12.7	±0.08	±0.08	±0.08	±0.08	---	±0.08
U	±0.13±0.38	±0.08±0.25	±0.13	15.875	±0.10	±0.10	±0.10	±0.10	---	±0.10
				19.05	±0.10	±0.10	±0.10	±0.10	---	±0.10
				25.4	---	±0.13	---	---	---	±0.13

内接圆直径 (mm)	刀片形状						
	C	D	R	S	T	V	W
3.97					06		
5.0			05				
5.56					09		
6.0			06				
6.35	06	07			11	11	
8.0			08				
9.525	09	11	09	09	16	16	06
10.0			10				
12.0			12				
12.7	12	15	12	12	22	22	08
15.875	16		15	15	27		
16.0		19	16				
19.05	19		19	19	33		
20.0			20				
25.0	25	25	25				
25.4			25	25			
31.75			31				
32			32				

切削刃长度

代号	刀片厚度(mm)
00	0.79
T0	0.99
01	1.59
T1	1.98
02	2.38
T2	2.58
03	3.18
T3	3.97
04	4.76
T4	4.96
05	5.96
T5	5.95
06	6.35
T6	6.75
07	7.94
09	9.52
T9	9.72
11	11.11
12	12.70

刀片厚度

12 04 ED T21 R-DM

修光刃			
代号	后角(度)	代号	后角(度)
A	45°	A	3°
D	60°	B	5°
E	75°	C	7°
F	85°	D	15°
P	90°	E	20°
Z	其它	F	25°
		G	30°
		N	0°
		P	11°
		Z	其它

切削刃倒棱(mm)			
代号	后角(度)	代号	后角(度)
F	0-5°		0-0.10
E	1-10°		1-0.15
T	2-15°		2-0.20
	3-20°		3-0.25
	4-25°		4-0.30
	5-30°		5-0.35
			6-0.40
S			7-0.45

断屑槽型代号

切削方向	
R	右
L	左
N	双向

铣削刀具 | MILLING TOOLS



可转位铣削刀具 Indexable milling tools

面铣刀具 Kr:45°



AF01



密齿等齿距

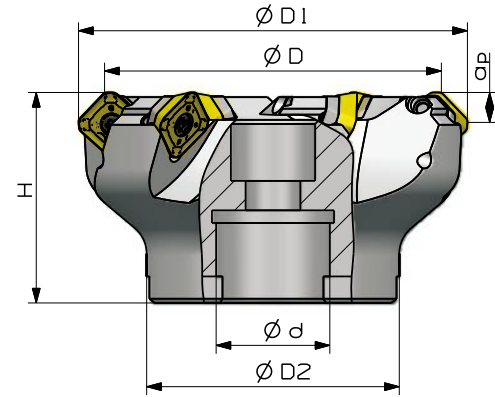

★ 刀具附件 Spare parts

刀片 Insert	刀垫 Shim	螺套 Threaded Sleeve	刀片螺钉 Insert Screw	扳手 Wrench	扳手 Wrench
SE□T12T3	S13BS	SM0508	TL60 M3.5X10	T15T	S3.5

注明：配套刀片与株洲钻石、三菱、山特、住友通用。Note: Insert can be Zccct/Mitsubishi/Sandvik/Sumitomo brands.

★ 刀具规格型号 Type of milling tools

Type 型号	基本尺寸(mm) Dimension						Adapter 接口 形式	Tooth 齿数	Weight 重量 (kg)
	ØD ₂	ØD ₁	ØD	Ød	H	ap			
AF01.12A22.050.04	40	62.4	50	22	40	6	A	4	0.3
AF01.12A22.063.05	50	75.4	63	22	40	6	A	5	0.5
AF01.12A27.080.06	60	92.4	80	27	50	6	A	6	1.3
AF01.12B32.100.07	70	112.4	100	32	50	6	B	7	1.8
AF01.12B40.125.08	80	137.4	125	40	63	6	B	8	3.0
AF01.12B40.160.10	100	172.4	160	40	63	6	B	10	5.0
AF01.12C60.200.12	160	212.4	200	60	63	6	C	12	6.8
AF01.12C60.250.14	200	262.4	250	60	63	6	C	14	11.2
AF01.12D60.315.18	270	327.4	315	60	70	6	D	18	20.8

了解具体库存情况请致电厂家 详情请登陆网站www.hnsant.com



铣削刀具 | MILLING TOOLS

Indexable milling tools 可转位铣削刀具

面铣刀具 Kr:45°



AF02



疏齿不等齿距

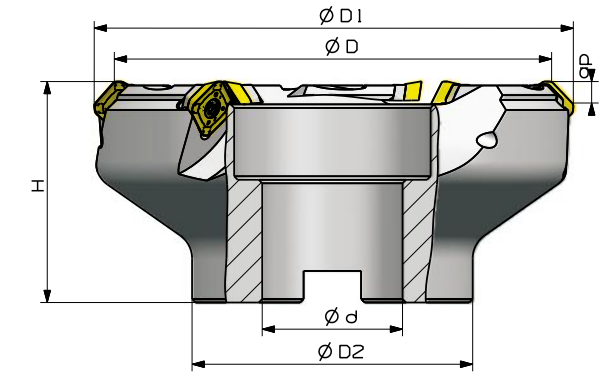

★ 刀具附件 Spare parts

刀片 Insert	刀垫 Shim	螺套 Threaded Sleeve	刀片螺钉 Insert Screw	扳手 Wrench	扳手 Wrench
SE□T12T3	S13BS	SM0508	TL60 M3.5X10	T15T	S3.5

注明：配套刀片与株洲钻石、三菱、山特、住友通用。Note: Insert can be Zccct/Mitsubishi/Sandvik/Sumitomo brands.

★ 刀具规格型号 Type of Milling Tools

Type 型号	基本尺寸(mm) Dimension						Adapter 接口 形式	Tooth 齿数	Weight 重量 (kg)
	ØD ₂	ØD ₁	ØD	Ød	H	ap			
AF02.12A22.050.03	40	62.4	50	22	40	6	A	3	0.3
AF02.12A22.063.04	50	75.4	63	22	40	6	A	4	0.5
AF02.12A27.080.04	60	92.4	80	27	50	6	A	4	1.2
AF02.12B32.100.05	70	112.4	100	32	50	6	B	5	1.8
AF02.12B40.125.06	80	137.4	125	40	63	6	B	6	3.55

了解具体库存情况请致电厂家 详情请登陆网站www.hnsant.com

★ 刀片选择 Matching Insert

型号 Type	基本尺寸(mm) Dimension											
	SD2136	SD2336	SD4326	SD5346	SD5236	SD5450	SD5440	L	ØI.C	S	Ød	bs
SEET12T3-FM	●	●	○			○	○	13.4	13.4	3.97	4.1	2.55
SEET12T3-SM	●	●	○	○	○	○	○	13.4	13.4	3.97	4.1	2.55
SEET12T3-SR		○					○	13.4	13.4	3.97	4.1	2.55
P 钢	■	■		■	■	■	■					
M 不锈钢	□	■			■	■						
K 铸铁		■	■	■								
N 有色金属												
S 耐热合金、钛合金		■										
H 淬硬材料												

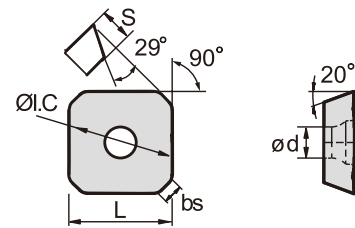

● 常备库存 Unallocated stock ○ 可备库存 Available stock ■ 推荐应用 Main application □ 拓展应用 Extended application

面铣刀具 Kr:45°



AF03

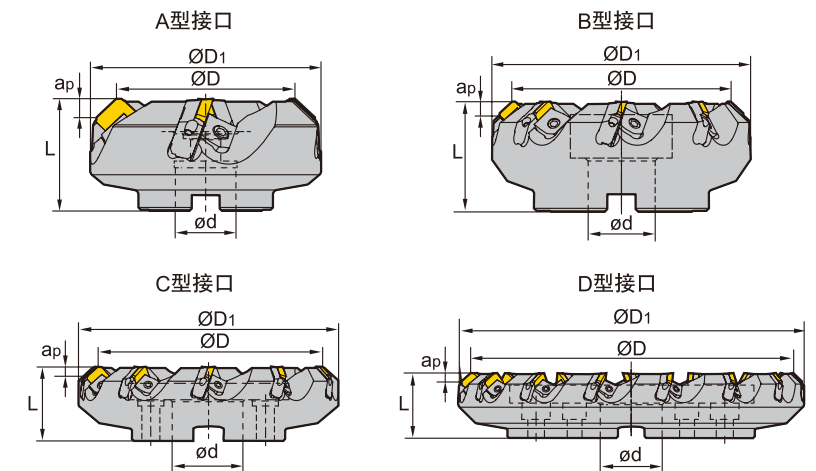

★ 刀具附件 Spare parts

刀片 Insert	刀夹 Tool chuck	压块 Clamp	双头螺钉 Double Headed Screw	刀夹螺钉 Tool chuck screw	扳手 Wrench
SE□N1203	LSE12R/L	W01R/L	DM8×21X	LOM5×15.1	S3
SE□N1504	LSE15R/L				S4

注明：配套刀片建议参考株洲钻石刀片。Note: The Insert Is Zccct Brand.

★ 刀具规格型号 Type of milling tools

Type 型号	基本尺寸(mm) Dimension					Adapter 接口形式	Tooth 齿数	Weight 重量 (kg)
	ØD	ØD1	Ød	L	apmax			
AF03.12A27.080.04	80	103	27	50	5.5	A	4	1.8
AF03.12B32.100.05	100	122	32	50	5.5	B	5	2.4
AF03.12B40.125.06	125	147	40	63	5.5	B	6	4.4
AF03.12B40.160.08	160	181	40	63	5.5	B	8	6.4
AF03.12C60.200.10	200	221	60	63	5.5	C	10	8.5
AF03.12C60.250.12	250	270	60	63	5.5	C	12	14.1
AF03.12D60.315.15	315	353	60	63	5.5	D	15	22.2
AF03.15A27.080.04	80	103	27	50	7.5	A	4	1.7
AF03.15B32.100.05	100	122	32	50	7.5	B	5	2.3
AF03.15B40.125.06	125	147	40	63	7.5	B	6	4.2
AF03.15B40.160.08	160	181	40	63	7.5	B	8	6.1
AF03.15C60.200.10	200	221	60	63	7.5	C	10	8.3
AF03.15C60.250.12	250	270	60	63	7.5	C	12	13.6
AF03.15D60.315.15	315	353	60	63	7.5	D	15	21.8

可转位铣削刀具 Indexable milling tools

面铣刀具 Kr:45°



AF04

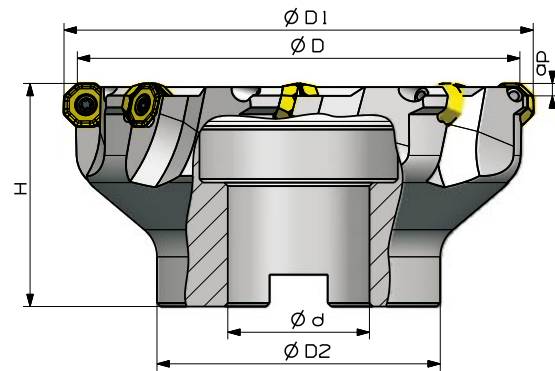

★ 刀具附件 Spare parts

刀片 Insert OFKT05T3	刀片螺钉 Insert Screw TL60 M4X10	扳手 Wrench T15T
---------------------------	-------------------------------------	-----------------------

注明：配套刀片建议参考株洲钻石刀片。Note: The Insert Is Zccct brand.

★ 刀具规格型号 Type of Milling Tools

Type 型号	基本尺寸(mm) Dimension						Adapter 接口形式	Tooth 齿数	Weight 重量 (kg)
	ØD ₂	ØD ₁	ØD	Ød	H	a _p			
AF04.05A22.050.04	40	56	50	22	40	3.5	A	4	0.3
AF04.05A22.050.05	40	56	50	22	40	3.5	A	5	0.4
AF04.05A22.063.05	50	69	63	22	40	3.5	A	5	0.6
AF04.05A27.080.06	60	86	80	27	50	3.5	A	6	1.3
AF04.05B32.100.07	70	106	100	30	50	3.5	B	7	2.6
AF04.05B40.125.08	80	130	125	40	63	3.5	B	8	4.2
AF04.05B40.160.10	100	165	160	40	63	3.5	B	10	5.1
AF04.05C40.160.10	100	165	160	40	63	3.5	C	10	4.8

了解具体库存情况请致电厂家 详情请登陆网站www.hnsant.com

Indexable milling tools 可转位铣削刀具

面铣刀具 Kr:45°



AF04

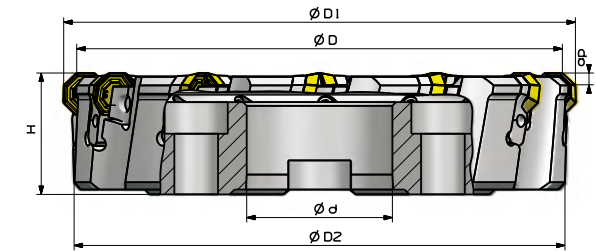

★ 刀具附件 Spare parts

刀片 Insert OFKR0704	刀夹 Tool chuck LOF07R/L	压块 Clamp W02R/L	双头螺钉 Double Headed Screw DM8*21	刀夹螺钉 Tool chuck screw LOM5X15	调节螺钉 Adjusting Screw TM0608	扳手 Wrench S3 S4
---------------------------	-------------------------------	------------------------	--	--------------------------------------	------------------------------------	------------------------

注明：配套刀片建议参考株洲钻石刀片。Note: The insert is Zccct brand.

★ 刀具规格型号 Type of milling tools

Type 型号	基本尺寸(mm) Dimension						Adapter 接口形式	Tooth 齿数	Weight 重量 (kg)
	ØD ₂	ØD ₁	ØD	Ød	H	a _p			
AF04.07A27.080.05	60	91	80	27	63	5	A	5	1.4
AF04.07B32.100.06	70	111	100	32	63	5	B	6	1.8
AF04.07B40.125.08	80	136	125	40	63	5	B	8	3.9
AF04.07B40.160.10	100	171	160	40	63	5	B	10	5.9
AF04.07C60.200.12	204	211	200	60	50	5	C	12	7.6
AF04.07C60.250.16	254	261	250	60	50	5	C	16	13.3
AF04.07D60.315.20	319	321	315	60	50	5	D	20	18.3

了解具体库存情况请致电厂家 详情请登陆网站www.hnsant.com

铣削刀具 | MILLING TOOLS



可转位铣削刀具 Indexable milling tools

面铣刀具 Kr:45°



AF05

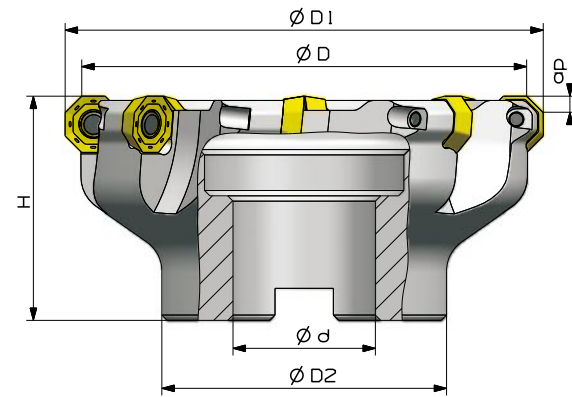

★ 刀具附件 Spare parts

刀片 Insert  OD□□0605	刀片螺钉 Insert Screw  TL60 M5X12	扳手 Wrench  T20T
--	--	--

注明：配套刀片建议参考瓦尔特刀片。Note:The Insert Is Walter brand.

★ 刀具规格型号 Type of Milling Tools

Type 型号	基本尺寸(mm) Dimension						Adapter 接口形式	Tooth 齿数	Weight 重量 (kg)
	$\varnothing D_2$	$\varnothing D_1$	$\varnothing D$	$\varnothing d$	H	a_p			
AF05.06A22.050.04	40	60	50	22	40	10	A	4	0.3
AF05.06A22.063.05	50	73	63	22	40	10	A	5	0.5
AF05.06A27.080.06	60	90	80	27	50	10	A	6	0.8
AF05.06B32.100.07	70	110	100	100	50	10	B	7	1.5
AF05.06B40.125.08	80	135	125	125	63	10	B	8	2.5
AF05.06C40.160.09	100	170	160	160	63	10	C	9	4

了解具体库存情况请致电厂家 详情请登陆网站www.hnsant.com



铣削刀具 | MILLING TOOLS

可转位铣削刀具 Indexable milling tools

面铣刀具 Kr:45°



AF06

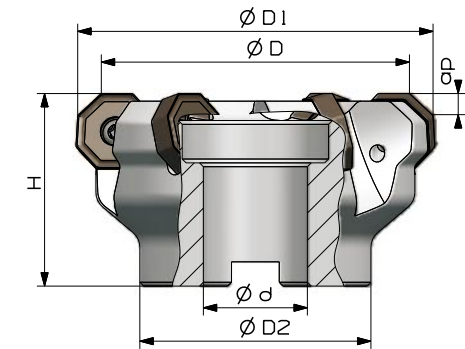

★ 刀具附件 Spare parts

刀片 Insert  ON□□0604□□	压紧螺钉 Clamping Screw  L60 M4X10	扳手 Wrench  T15T
ON□□08T5□□	L60 M5X12	T20T

注明：配套刀片建议参考株洲钻石刀片。Note:The insert is Zccct brand.

★ 刀具规格型号 Type of milling tools

Category 类别	Type 型号	基本尺寸(mm) Dimension						Adapter 接口形式	Tooth 齿数	Weight 重量 (kg)
		$\varnothing D_2$	$\varnothing D_1$	$\varnothing D$	$\varnothing d$	H	a_p			
ON06	AF06.06A22.050.05	40	62	50	22	45	4	A	5	0.3
	AF06.06A22.063.06	50	75	63	22	45	4	A	6	0.5
	AF06.06B27.080.07	60	92	80	27	50	4	B	7	1.2
	AF06.06B32.100.08	70	112	100	32	63	4	B	8	1.2
	AF06.06B40.125.09	80	137	125	40	63	4	B	9	2.6
	AF06.06C40.160.11	100	172	160	40	63	4	C	11	4.3
	AF06.06C60.200.13	160	212	200	60	63	4	C	13	7.6
	AF06.06C60.250.15	200	262	250	60	63	4	C	15	13.5
ON08	AF06.06D60.315.17	250	327	315	60	70	4	D	17	20.8
	AF06.08A22.063.05	50	78	63	22	40	5	A	5	0.5
	AF06.08B27.080.06	60	95	80	27	50	5	B	6	1.2
	AF06.08B32.100.07	70	115	100	32	63	5	B	7	1.2
	AF06.08B40.125.08	80	140	125	40	63	5	B	8	2.6
	AF06.08C40.160.10	100	175	160	40	63	5	C	10	4.3
	AF06.08C60.200.12	160	215	200	60	63	5	C	12	7.6
	AF06.08C60.250.14	200	265	250	60	63	5	C	14	13.5
AF06.08D60.315.16	250	330	315	60	70	5	D	16	20.8	

了解具体库存情况请致电厂家 详情请登陆网站www.hnsant.com

铣削刀具 | MILLING TOOLS



可转位铣削刀具 Indexable milling tools

面铣刀具 Kr:45°



AF06

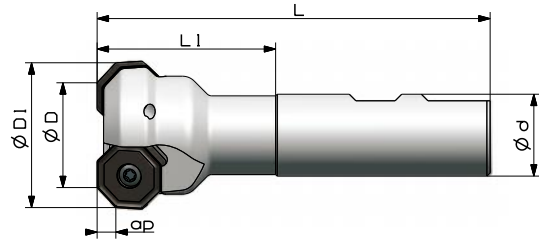

★ 刀具附件 Spare parts

刀片 Insert	刀片螺钉 Insert Screw	扳手 Wrench
 ON□□0604□□	 TL60 M4X10	 T15
ON□□08T5□□	TL60 M5X12	T20

注明：配套刀片建议参考株洲钻石刀片。 Note: The Insert Is Zccct brand.

★ 刀具规格型号 Type of Milling Tools

Type 型号	基本尺寸(mm) Dimension						Adapter 接口 形式	Tooth 齿数	Weight 重量 (kg)
	$\varnothing D_1$	$\varnothing D$	$\varnothing d$	L	L ₁	a _p			
AF06.06W20.025.02	37	25	20	100	45	4	W	2	0.2
AF06.06W25.032.03	44	32	25	110	50	4	W	3	0.3
AF06.06W32.040.04	52	40	32	120	55	4	W	4	0.4
AF06.08W25.032.02	47	32	25	120	55	5	W	2	0.4
AF06.08W32.040.03	55	40	32	120	55	5	W	3	0.5
AF06.08W32.050.04	65	50	32	120	55	5	W	4	0.6

了解具体库存情况请致电厂家 详情请登陆网站www.hnsant.com



铣削刀具 | MILLING TOOLS

Indexable milling tools 可转位铣削刀具

面铣刀具 Kr:45°



AF08

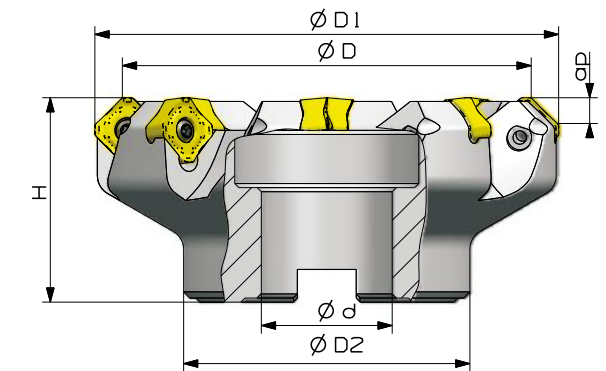

★ 刀具附件 Spare parts

刀片 Insert	刀片螺钉 Insert Screw	扳手 Wrench
 SNEX1206ANN	 TL60 M4X10	 T15T

注明：配套刀片建议参考克洛伊刀片。 Note: The insert is Korloy brand.

★ 刀具规格型号 Type of Milling Tools

Type 型号	基本尺寸(mm) Dimension						Adapter 接口 形式	Tooth 齿数	Weight 重量 (kg)
	$\varnothing D_2$	$\varnothing D_1$	$\varnothing D$	$\varnothing d$	H	a _p			
AF08.12A22.050.04	40	63	50	22	40	6	A	4	0.5
AF08.12A22.063.06	50	76	63	22	40	6	A	6	0.7
AF08.12B27.080.07	60	93	80	27	50	6	B	7	1.2
AF08.12B32.100.08	70	113	100	32	50	6	B	8	1.7
AF08.12B40.125.10	80	138	125	40	63	6	B	10	3.6
AF08.12C40.160.12	100	173	160	40	63	6	C	12	4.8
AF08.12C60.200.14	150	213	200	60	63	6	C	14	5.3
AF08.12C60.250.16	180	263	250	60	63	6	C	16	12

了解具体库存情况请致电厂家 详情请登陆网站www.hnsant.com

铣削刀具 | MILLING TOOLS



可转位铣削刀具 Indexable milling tools

面铣刀具 Kr:45°



AF09

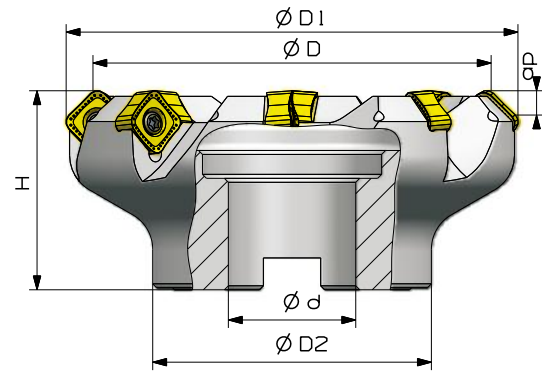

★ 刀具附件 Spare parts

刀片 Insert 	刀片螺钉 Insert Screw 	扳手 Wrench
SNMX1205XTN	TL60 M4X10	T15T

注明：配套刀片建议参考特固克刀片。Note: The insert is Taegutec brand

★ 刀具规格型号 Type of milling tools

Type 型号	基本尺寸(mm) Dimension						Adapter 接口 形式	Tooth 齿数	Weight 重量 (kg)
	ØD ₂	ØD ₁	ØD	ød	H	ap			
AF09.12A22.050.04	40	63	50	22	40	6	A	4	0.5
AF09.12A22.063.05	50	76	63	22	40	6	A	5	0.7
AF09.12B27.080.06	60	93	80	27	50	6	B	6	1.2
AF09.12B32.100.08	70	113	100	32	50	6	B	8	1.7
AF09.12B40.125.10	80	138	125	40	63	6	B	10	3.6
AF09.12C40.160.14	100	173	160	40	63	6	C	14	4.8
AF09.12C60.200.18	150	213	200	60	63	6	C	18	5.3
AF09.12C60.250.20	180	263	250	60	63	6	C	20	12

了解具体库存情况请致电厂家 详情请登陆网站www.hnsant.com



铣削刀具 | MILLING TOOLS

Indexable milling tools 可转位铣削刀具

面铣刀具 Kr:45°



AF10

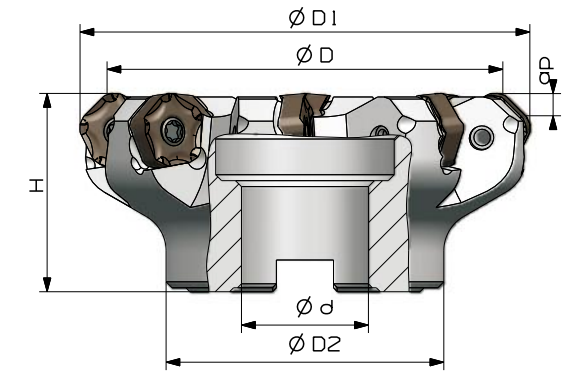

★ 刀具附件 Spare parts

刀片 Insert 	刀片螺钉 Insert Screw 	扳手 Wrench
PNMU1205ANER	TL60 M5X12	T20T

注明：配套刀片建议参考京瓷刀片。Note: The insert is Kyocera brand.

★ 刀具规格型号 Type of Milling Tools

Type 型号	基本尺寸(mm) Dimension						Adapter 接口 形式	Tooth 齿数	Weight 重量 (kg)
	ØD ₂	ØD ₁	ØD	ød	H	ap			
AF10.12A22.063.05	50	76	63	22	45	5.5	A	5	0.5
AF10.12B27.080.06	60	93	80	27	50	5.5	B	6	1.0
AF10.12B32.100.08	70	113	100	32	50	5.5	B	8	1.4
AF10.12B40.125.10	80	138	125	40	63	5.5	B	10	2.5
AF10.12C40.160.12	100	173	160	40	63	5.5	C	12	3.8
AF10.12C60.200.14	150	213	200	60	63	5.5	C	14	6.5
AF10.12C60.250.16	180	263	250	60	63	5.5	C	16	9.1

了解具体库存情况请致电厂家 详情请登陆网站www.hnsant.com

可转位铣削刀具 Indexable milling tools

面铣刀具 Kr:45°



AF11

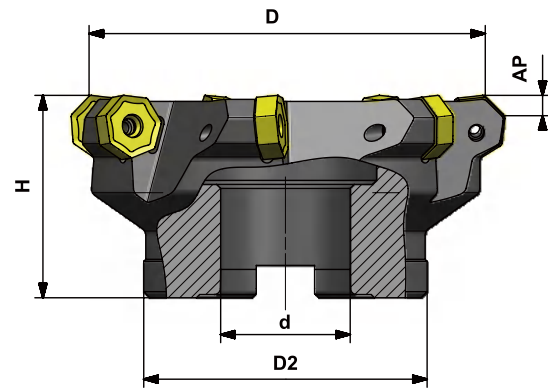

★ 刀具附件 Spare parts

刀片 Insert 	刀片螺钉 Insert Screw 	扳手 Wrench
XNMX070508	TL60M3.5X10	T15

注明：配套刀片与株洲钻石、瓦尔特通用。Note: Insert can be Zccct/Walter brands.

★ 刀具规格型号 Type of milling tools

Type 型号	基本尺寸(mm) Dimension					Adapter 接口 形式	Tooth 齿数	Weight 重量 (kg)
	ØD ₂	ØD	Ød	H	a _p			
AF11.07A22.050.04	40	50	22	40	4.5	A	4	0.3
AF11.07A22.063.05	50	63	22	40	4.5	A	5	0.5
AF11.07A27.080.06	60	80	27	50	4.5	A	6	1.2
AF11.07B32.100.07	70	100	32	50	4.5	B	7	1.7
AF11.07B40.125.08	80	125	40	63	4.5	B	8	3.0
AF11.07B40.160.10	100	160	40	63	4.5	B	10	5.2

Indexable milling tools 可转位铣削刀具

★ 刀片选择 Matching Insert

型号 Type	基本尺寸(mm) Dimension															
	SP210M	SD2136	SD2336	SD4326	SD4226	SD4236	SD5346	SD5236	SD5450	SD5440	SD5146	L	ØI.C	S	Ød	r
XNMX070508-GM	●											6.98	14.5	5.36	4.0	0.8
XNMU0705ZNN	○	●	○	○								6.98	14.5	5.36	4.0	0.8
XNMU0705ANN	○	●	○	○								6.98	14.5	5.36	4.0	0.8
P 钢	□	■	■													
M 不锈钢	□	□	■													
K 铸铁	■	■	■	■												
N 有色金属																
S 耐热合金、钛合金		■														
H 淬硬材料																

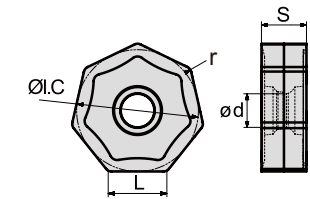

● 常备库存 Unallocated stock ○ 可备库存 Available stock ■ 推荐应用 Main application □ 拓展应用 Extended application

铣削刀具 | MILLING TOOLS



可转位铣削刀具 Indexable milling tools

面铣刀具 Kr:45°



AF12

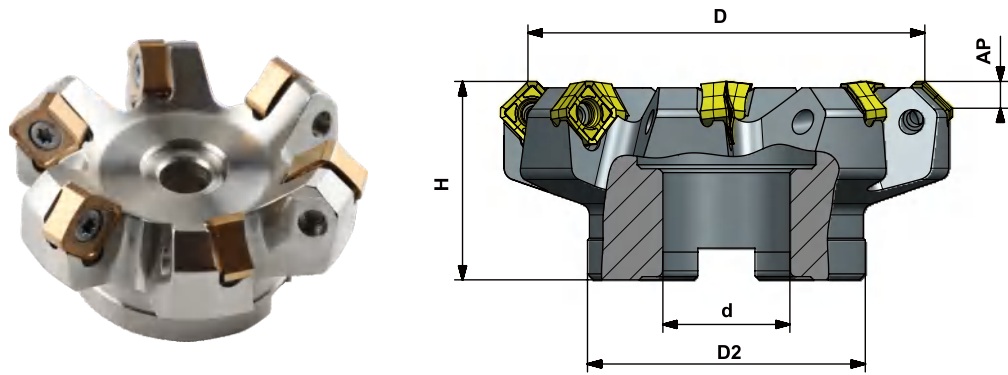

★ 刀具附件 Spare parts

刀片 Insert	刀片螺钉 Insert Screw	扳手 Wrench
SNGX1205ANN	TL60M5X13	T20

注明：配套刀片与株洲钻石、瓦尔特、克洛伊通用。Note: Insert can be Zccct/Walter/Kolory brands.

★ 刀具规格型号 Type of milling tools

Type 型号	基本尺寸(mm) Dimension					Adapter 接口 形式	Tooth 齿数	Weight 重量 (kg)
	ØD ₂	ØD	Ød	H	a _p			
AF12.12A22.050.04	40	50	22	40	6.5	A	4	0.3
AF12.12A22.063.06	50	63	22	40	6.5	A	6	0.5
AF12.12A27.080.07	60	80	27	50	6.5	A	7	1.2
AF12.12B32.100.08	70	100	32	50	6.5	B	8	1.8
AF12.12B40.125.10	80	125	40	63	6.5	B	10	3.1
AF12.12B40.160.12	100	160	40	63	6.5	B	12	5.5

了解具体库存情况请致电厂家 详情请登陆网站www.hnsant.com



铣削刀具 | MILLING TOOLS

Indexable milling tools 可转位铣削刀具

★ 刀片选择 Matching Insert

型号 Type	SP210M	SP210T	SD2136	SD2336	SD4326	SD4226	SD4236	SD5346	SD5236	SD5450	SD5440	SD5146	基本尺寸(mm) Dimension				
													L	ØI.C	S	Ød	r
SNGX1205ANN	○	○											12.7	12.7	6.5	5.9	0.8
SNMX1205ANN			●	●	○	○	○	○			●		12.7	12.7	6.5	5.9	0.8

P 钢	<input type="checkbox"/>	<input checked="" type="checkbox"/>	<input checked="" type="checkbox"/>	<input checked="" type="checkbox"/>				<input checked="" type="checkbox"/>			<input checked="" type="checkbox"/>						
M 不锈钢	<input type="checkbox"/>	<input type="checkbox"/>	<input type="checkbox"/>	<input checked="" type="checkbox"/>													
K 铸铁	<input checked="" type="checkbox"/>	<input type="checkbox"/>		<input checked="" type="checkbox"/>	<input checked="" type="checkbox"/>	<input checked="" type="checkbox"/>	<input checked="" type="checkbox"/>										
N 有色金属																	
S 耐热合金、钛合金				<input checked="" type="checkbox"/>													
H 淬硬材料																	

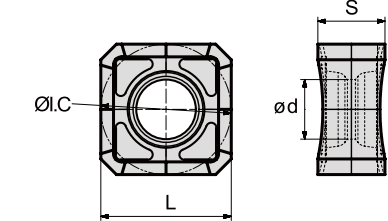

● 常备库存 Unallocated stock ○ 可备库存 Available stock ■ 推荐应用 Main application □ 拓展应用 Extended application

了解具体库存情况请致电厂家 详情请登陆网站www.hnsant.com

可转位铣削刀具 Indexable milling tools

面铣刀具 Kr:55°



DF01

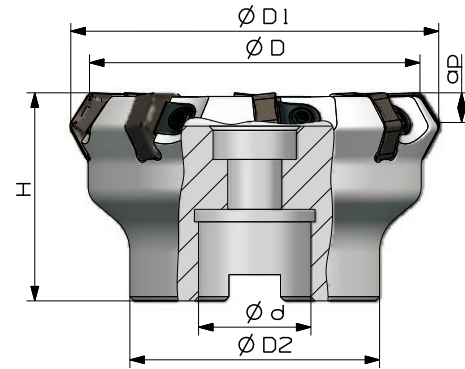

★ 刀具附件 Spare parts

刀片 Insert	压紧螺钉 Clamping Screw	压块 Clamp	扳手 Wrench
HNEX0905	进口: DM6*20	W18N	S3

注明: 配套刀片建议参考株洲钻石刀片。 Note: The insert is Zccct brand.

★ 刀具规格型号 Type of Milling Tools

Type 型号	基本尺寸(mm) Dimension						Adapter 接口形式	Tooth 齿数	Weight 重量 (kg)
	$\varnothing D_2$	$\varnothing D_1$	$\varnothing D$	$\varnothing d$	H	a_p			
DF01.09A27.080.08	60	88.5	80	27	50	8.5	A	8	1.1
DF01.09B32.100.10	70	108.5	100	32	50	8.5	B	10	2.6
DF01.09B40.125.14	80	133.5	125	40	63	8.5	B	14	3.7
DF01.09B40.160.18	100	168.5	160	40	63	8.5	B	18	5.6
DF01.09C60.200.22	150	208.5	200	60	63	8.5	C	22	6.3
DF01.09C60.250.28	200	258.5	250	60	63	8.5	C	28	10.3
DF01.09D60.315.32	270	323.5	315	60	63	8.5	D	32	21.7

了解具体库存情况请致电厂家 详情请登陆网站www.hnsant.com

Indexable milling tools 可转位铣削刀具

面铣刀具 Kr:67°

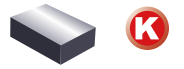

DF01

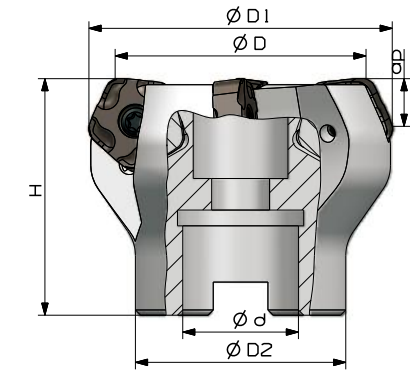

★ 刀具附件 Spare parts

刀片 Insert	刀片螺钉 Insert Screw	扳手 Wrench
PNEG110512R	TL60 M4X10	T15T

注明: 配套刀片建议参考株洲钻石刀片。 Note: The insert is Zccct brand.

★ 刀具规格型号 Type of milling tools

Category 类别	Type 型号	基本尺寸(mm) Dimension						Adapter 接口形式	Tooth 齿数	Weight 重量 (kg)
		$\varnothing D_2$	$\varnothing D_1$	$\varnothing D$	$\varnothing d$	H	a_p			
标准型	DF01.11A22.050.04	40	60	50	22	45	5	A	4	0.6
	DF01.11A22.063.05	50	73	63	22	50	5	A	5	0.8
	DF01.11B27.080.06	60	90	80	27	50	5	B	6	1.1
	DF01.11B32.100.07	70	110	100	32	50	5	B	7	1.8
	DF01.11B40.125.08	80	135	125	40	63	5	B	8	2.9
	DF01.11B40.160.10	100	170	160	40	63	5	B	10	5.6
	DF01.11C60.200.12	150	210	200	60	63	5	C	12	7.9
多刃型	DF01.11C60.250.14	180	260	250	60	63	5	C	14	13.4
	DF01.11A22.050.05	40	60	50	22	45	5	A	5	0.6
	DF01.11A22.063.06	50	73	63	22	50	5	A	6	0.9
	DF01.11B27.080.08	60	90	80	27	50	5	B	8	1.2
	DF01.11B32.100.10	70	110	100	32	50	5	B	10	1.9
	DF01.11B40.125.12	80	135	125	40	63	5	B	12	3.2
	DF01.11B40.160.14	100	170	160	40	63	5	B	14	6.4
DF01.11C60.200.16	150	210	200	60	63	5	C	16	8.5	
DF01.11C60.250.18	180	260	250	60	63	5	C	18	18	

了解具体库存情况请致电厂家 详情请登陆网站www.hnsant.com

面铣刀具 Kr:67°

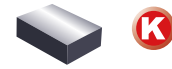

DF01

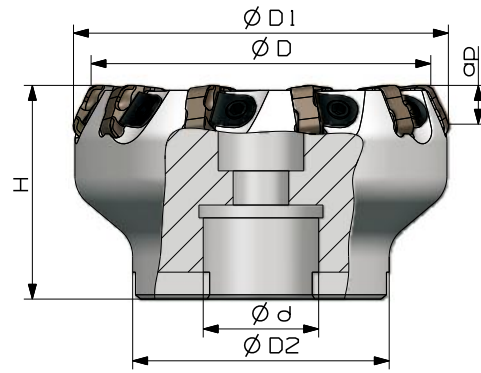
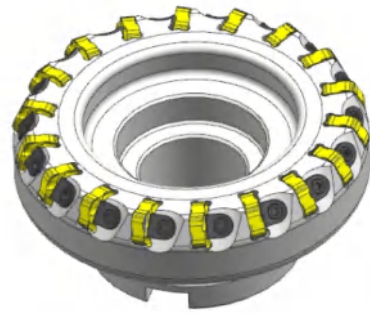

★ 刀具附件 Spare parts

刀片 Insert 	压紧螺钉 Clamping Screw 	压板 Clamp 	扳手 Wrench
PNEG110512R	DM6*20	W18N	S3

注明：配套刀片建议参考株洲钻石刀片。Note: The insert is Zccct brand.

★ 刀具规格型号 Type of Milling Tools

Category 类别	Type 型号	基本尺寸(mm) Dimension						Adapter 接口 形式	Tooth 齿数	Weight 重量 (kg)
		ØD ₂	ØD ₁	ØD	Ød	H	ap			
密齿型	DF01.11A27.080.10	60	90.1	80	27	50	5	A	10	1.3
	DF01.11B32.100.14	70	110.1	100	32	50	5	B	14	1.6
	DF01.11B40.125.18	80	135.1	125	40	63	5	B	18	3.2
	DF01.11B40.160.22	100	170.1	160	40	63	5	B	22	5.8

面铣刀具 Kr:60°



DF02

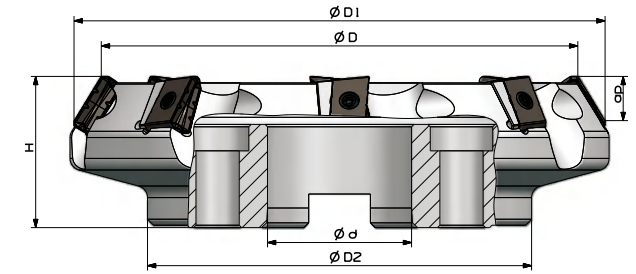
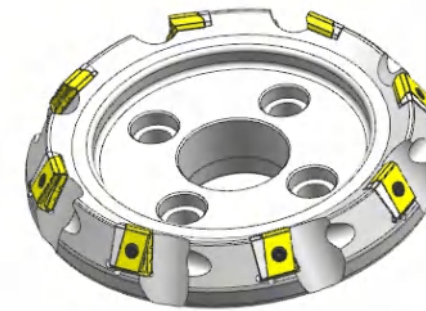

★ 刀具附件 Spare parts

刀片 Insert 	刀垫 Shim 	刀片螺钉 Insert Screw 	刀垫螺钉 Shim Screw 	扳手 Wrench
LNKT2510	LLN25R-ZR	TL60 M5X16	L60 M3.5X10	T15T/T20T

注明：配套刀片建议参考株洲钻石刀片。Note: The insert is Zccct brand.

★ 刀具规格型号 Type of milling tools

Type 型号	基本尺寸(mm) Dimension						Adapter 接口 形式	Tooth 齿数	Weight 重量 (kg)
	ØD ₂	ØD ₁	ØD	Ød	H	ap			
DF02.25B40.125.05	80	154	125	40	63	17	B	5	4.5
DF02.25C40.160.06	100	189	160	40	63	17	C	6	6.9
DF02.25C60.200.08	150	229	200	60	63	17	C	8	10.5
DF02.25C60.250.10	160	278	250	60	63	17	C	10	16.7
DF02.25D60.315.12	270	346	315	60	63	17	D	12	27.3

面铣刀具 Kr:65°



DF03

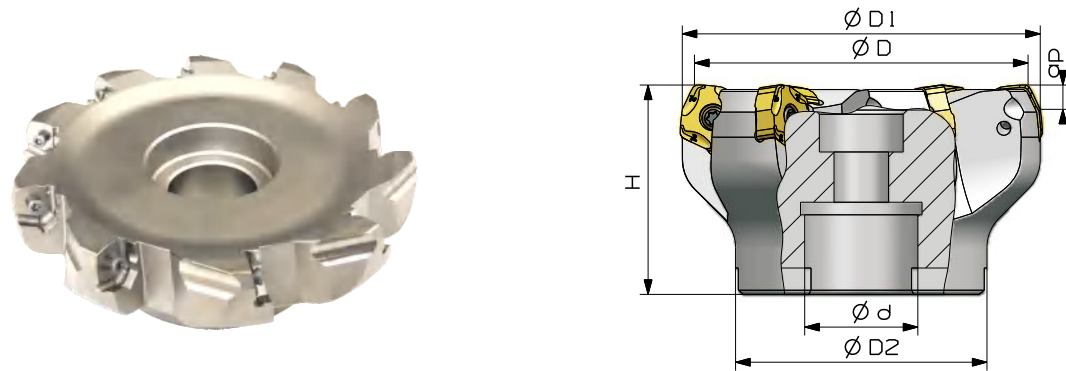

★ 刀具附件 Spare parts

刀片 Insert 	刀片螺钉 Insert Screw 	扳手 Wrench
R365-1505ZNE	TL60 M4X10	T15T

注明：配套刀片建议参考山特维克刀片。 Note: The insert is Sandvik brand.

★ 刀具规格型号 Type of Milling Tools

Type 型号	基本尺寸(mm) Dimension						Adapter 接口 形式	Tooth 齿数	Weight 重量 (kg)
	ØD ₂	ØD ₁	ØD	Ød	H	a _p			
DF03.15A22.050.04	40	57	50	22	40	6	A	4	0.5
DF03.15A22.063.05	50	70	63	22	40	6	A	5	0.7
DF03.15A27.080.06	60	87	80	27	50	6	A	6	1.1
DF03.15B32.100.07	70	107	100	32	50	6	B	7	1.8
DF03.15B40.125.08	80	132	125	40	63	6	B	8	3.4
DF03.15B40.160.10	100	167	160	40	63	6	B	10	5.2
DF03.15C60.200.12	150	207	200	60	63	6	C	12	7.8

面铣刀具 Kr:65°



DF03

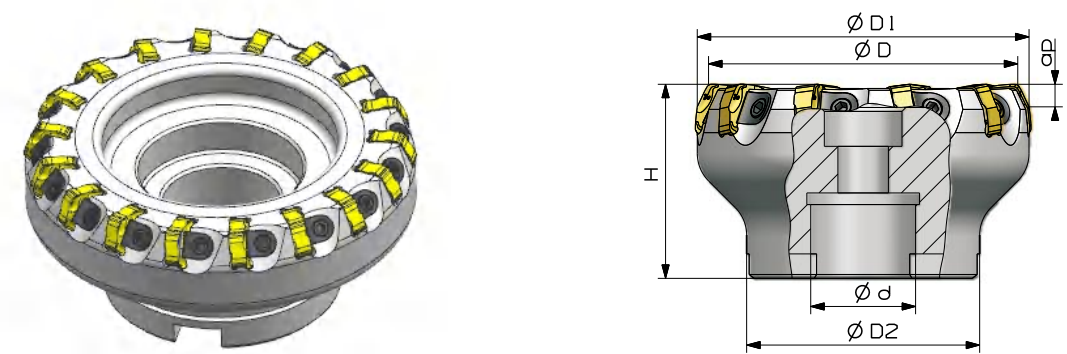

★ 刀具附件 Spare parts

刀片 Insert 	压紧螺钉 Clamping Screw 	压块 Clamp 	扳手 Wrench
R365-1505ZNE	DM6*20	W18N	S3

注明：配套刀片建议参考山特维克刀片。 Note: The insert is Sandvik brand.

★ 刀具规格型号 Type of milling tools

Type 型号	基本尺寸(mm) Dimension						Adapter 接口 形式	Tooth 齿数	Weight 重量 (kg)
	ØD ₂	ØD ₁	ØD	Ød	H	a _p			
DF03.15A27.080.10	60	87	80	27	50	6	A	10	1.4
DF03.15B32.100.14	70	107	100	32	50	6	B	14	2.0
DF03.15B40.125.18	80	132	125	40	63	6	B	18	3.8
DF03.15B40.160.22	100	167	160	40	63	6	B	22	5.7
DF03.15C60.200.28	150	207	200	60	63	6	C	28	10.2
DF03.15C60.250.36	180	257	250	60	63	6	C	36	15.2

面铣刀具 Kr:75°



EF02

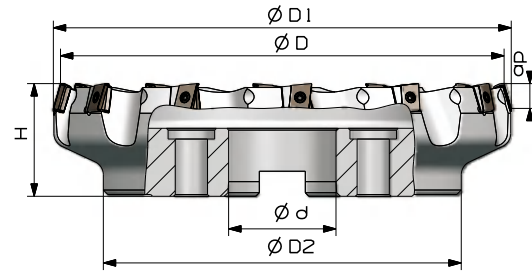
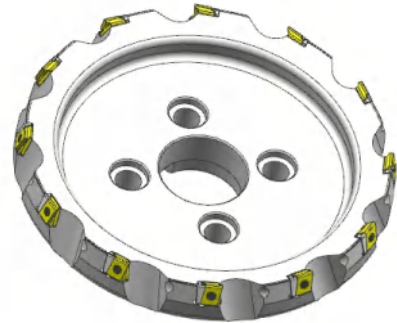

★ 刀具附件 Spare parts

刀片 Insert	刀垫 Shim	刀片螺钉 Insert Screw	刀垫螺钉 Shim Screw	扳手 Wrench
LNKT1506	LLN15R-ZR	TL60 M4X15	L60 M3X8	T10T/T15T

注明：配套刀片建议参考株洲钻石刀片。 Note: The insert is Zccct brand.

★ 刀具规格型号 Type of milling tools

Type 型号	基本尺寸(mm) Dimension						Adapter 接口形式	Tooth 齿数	Weight 重量 (kg)
	ØD ₂	ØD ₁	ØD	ød	H	ap			
EF02.15B40.125.06	80	137	125	40	63	8	B	6	3.8
EF02.15B40.160.08	100	170	160	40	63	8	B	8	6.6
EF02.15C60.200.10	150	208	200	60	63	8	C	10	9.6
EF02.15C60.250.12	200	257	250	60	63	8	C	12	13.4
EF02.15D60.315.16	250	328	315	60	63	8	D	16	25.2

了解具体库存情况请致电厂家 详情请登陆网站www.hnsant.com

面铣刀具 Kr:75°



EF03

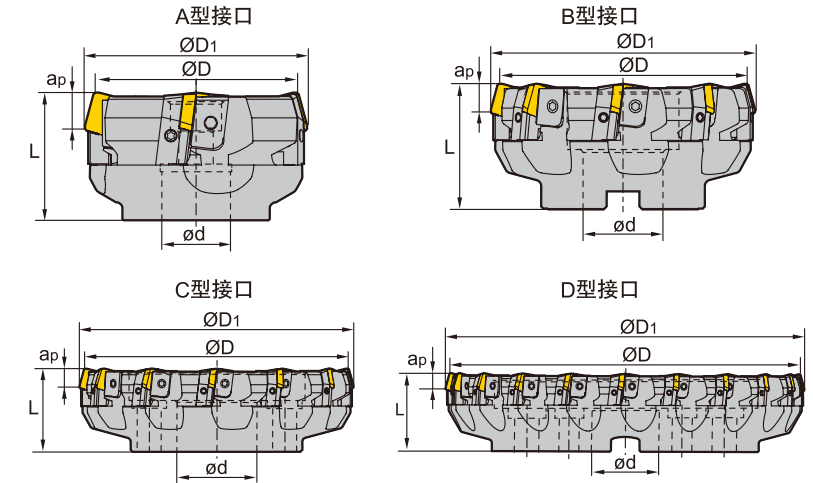
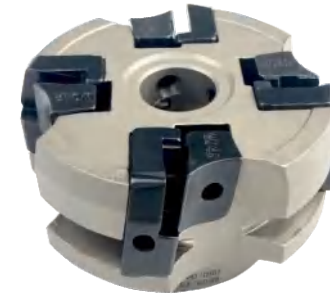

★ 刀具附件 Spare parts

刀片 Insert	刀夹 Tool chuck	压块 Clamp	压紧螺钉 Clamping Screw	刀夹螺钉 Tool chuck screw	扳手 Wrench
SPKN1203	LSP12R/L	W04R/L	WM8×17	LOM5×15.1	S3
SPKN1203	LSP12R/L	W04R/L	WM8×22		S4
SPKN1504	LSP15R/L	W04R/L	WM8×22		

注明：配套刀片建议参考株洲钻石刀片。 Note: The insert is Zccct brand.

★ 刀具规格型号 Type of Milling Tools

Type 型号	基本尺寸(mm) Dimension					Adapter 接口形式	Tooth 齿数	Weight 重量 (kg)
	ØD	ØD ₁	ød	L	ap			
EF03.12A27.080.04	80	84	27	50	6	4	A	1.1
EF03.12B27.100.06	100	104	27	50	6	6	B	1.9
EF03.12B40.125.08	125	129	40	63	6	8	B	3.5
EF03.12B40.160.10	160	164	40	63	6	10	B	5.7
EF03.12C60.200.12	200	203	60	63	6	12	C	8.2
EF03.12C60.250.16	250	253	60	63	6	16	C	13.8
EF03.12D60.315.20	315	318	60	70	6	20	D	23.5
EF03.15A27.080.04	80	84	27	50	8	4	A	1.0
EF03.15B27.100.06	100	104	27	50	8	6	B	1.8
EF03.15B40.125.08	125	129	40	63	8	8	B	3.3
EF03.15B40.160.10	160	164	40	63	8	10	B	5.4
EF03.15C60.200.12	200	204	60	63	8	12	C	7.9
EF03.15C60.250.16	250	253	60	63	8	16	C	13.6
EF03.15D60.315.20	315	318	60	70	8	20	D	23.1

了解具体库存情况请致电厂家 详情请登陆网站www.hnsant.com

可转位铣削刀具 Indexable milling tools

面铣刀具 Kr:75°



EF04

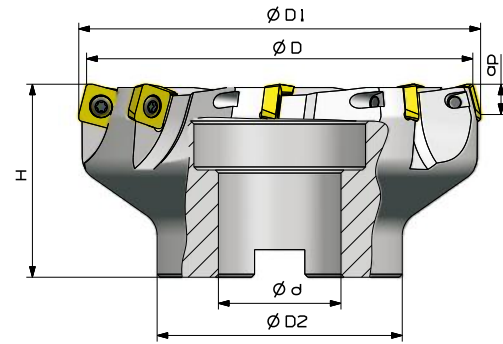

★ 刀具附件 Spare parts

刀片 Insert 	刀片螺钉 Insert Screw 	扳手 Wrench
SPK□1204	TL60 M5X12	T20T

注明：配套刀片建议参考株洲钻石刀片。 Note: The insert is Zccct brand.

★ 刀具规格型号 Type of milling tools

Type 型号	基本尺寸(mm) Dimension						Adapter 接口形式	Tooth 齿数	Weight 重量 (kg)
	ØD ₂	ØD ₁	ØD	Ød	H	a _p			
EF04.12A22.050.04	40	54	50	22	40	6	A	4	0.3
EF04.12A22.063.05	50	66	63	22	50	6	A	5	0.6
EF04.12A27.080.06	60	83	80	27	50	6	A	6	0.9
EF04.12B32.100.07	70	103	100	32	50	6	B	7	1.4
EF04.12B40.125.08	80	128	125	40	63	6	B	8	2.5

了解具体库存情况请致电厂家 详情请登陆网站www.hnsant.com

Indexable milling tools 可转位铣削刀具

面铣刀具 Kr:75°



EF06

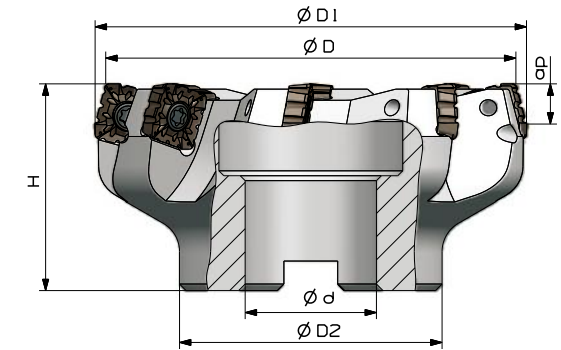

★ 刀具附件 Spare parts

刀片 Insert 	压紧螺钉 Clamping Screw 	扳手 Wrench
SPMT1806EDER	TL60 M6X16	T25T

注明：配套刀片建议参考京瓷刀片。 Note: The insert is Kyocera brand.

★ 刀具规格型号 Type of milling tools

Category 类别	Type 型号	基本尺寸(mm) Dimension						Adapter 接口形式	Tooth 齿数	Weight 重量 (kg)
		ØD ₂	ØD ₁	ØD	Ød	H	a _p			
标准型	EF06.18A27.080.04	60	87	80	27	50	12.4	A	4	1.3
	EF06.18B32.100.05	70	107	100	32	50	12.4	B	5	2.0
	EF06.18B40.125.06	80	132	125	40	63	12.4	B	6	3.6
	EF06.18B40.160.08	100	167	160	40	63	12.4	B	8	5.0
	EF06.18C60.200.10	150	207	200	60	63	12.4	C	10	7.7
	EF06.18C60.250.12	180	257	250	60	63	12.4	C	12	12.0
多刃型	EF06.18A27.080.06	60	87	80	27	50	12.4	A	6	1.3
	EF06.18B32.100.07	70	107	100	32	50	12.4	B	7	1.9
	EF06.18B40.125.08	80	132	125	40	63	12.4	B	8	3.5
	EF06.18B40.160.10	100	167	160	40	63	12.4	B	10	4.9
	EF06.18C60.200.12	150	207	200	60	63	12.4	C	12	7.6
	EF06.18C60.250.14	180	257	250	60	63	12.4	C	14	17.0

了解具体库存情况请致电厂家 详情请登陆网站www.hnsant.com

铣削刀具 | MILLING TOOLS



可转位铣削刀具 Indexable milling tools

面铣刀具 Kr:75°



EF08

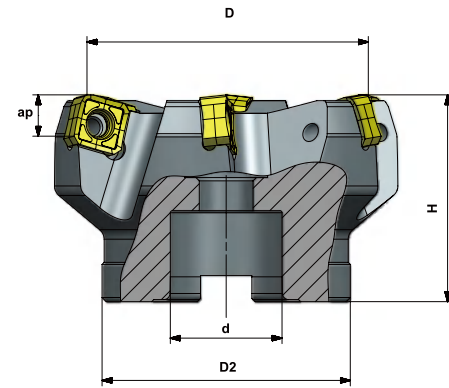

★ 刀具附件 Spare parts

刀片 Insert	压紧螺钉 Clamping Screw	扳手 Wrench
 SNGX1205ENN	 TL60M5X13	 T20

注明：配套刀片与株洲钻石、瓦尔特、克洛伊通用。Note: Insert can be Zccct/Walter/Kolory brands.

★ 刀具规格型号 Type of milling tools

Type 型号	基本尺寸(mm) Dimension					Adapter 接口 形式	Tooth 齿数	Weight 重量 (kg)
	ØD ₂	ØD	Ød	H	ap			
EF08.12A22.050.04	40	50	22	40	8	A	4	0.3
EF08.12A22.063.05	50	63	22	40	8	A	5	0.5
EF08.12A27.080.06	60	80	27	50	8	A	6	1.2
EF08.12B32.100.07	70	100	32	50	8	B	7	1.7
EF08.12B40.125.08	80	125	40	63	8	B	8	3.0
EF08.12B40.160.10	100	160	40	63	8	B	10	4.5

了解具体库存情况请致电厂家 详情请登陆网站www.hnsant.com



铣削刀具 | MILLING TOOLS

Indexable milling tools 可转位铣削刀具

★ 刀片选择 Matching Insert

型号 Type	SP210M	SP210T	SD2136	SD2336	SD4326	SD4226	SD4236	SD5346	SD5236	SD5450	SD5440	SD5146	基本尺寸(mm) Dimension				
	L	Ø1.C	S	Ød	r						L	Ø1.C	S	Ød	r		
SNGX1205ENN	○	○											12.7	12.7	6.5	5.9	0.8
SNMX1205ANN			●	●	○	○	○	○			●		12.7	12.7	6.5	5.9	0.8

P 钢	<input type="checkbox"/>	<input checked="" type="checkbox"/>	<input checked="" type="checkbox"/>	<input checked="" type="checkbox"/>				<input checked="" type="checkbox"/>		<input checked="" type="checkbox"/>							
M 不锈钢	<input type="checkbox"/>	<input type="checkbox"/>	<input type="checkbox"/>	<input checked="" type="checkbox"/>													
K 铸铁	<input checked="" type="checkbox"/>	<input type="checkbox"/>		<input checked="" type="checkbox"/>	<input checked="" type="checkbox"/>	<input checked="" type="checkbox"/>	<input checked="" type="checkbox"/>										
N 有色金属																	
S 耐热合金、钛合金				<input checked="" type="checkbox"/>													
H 淬硬材料																	

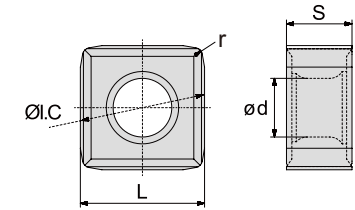

● 常备库存 Unallocated stock ○ 可备库存 Available stock ■ 推荐应用 Main application □ 拓展应用 Extended application

了解具体库存情况请致电厂家 详情请登陆网站www.hnsant.com

铣削刀具 | MILLING TOOLS



可转位铣削刀具 Indexable milling tools

面铣刀具 Kr:88°



PF88

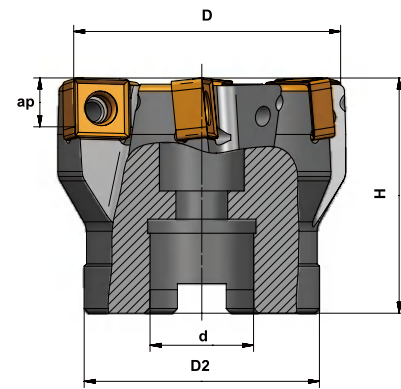

★ 刀具附件 Spare parts

刀片 Insert	压紧螺钉 Clamping Screw	扳手 Wrench
 SNGX1205PNN	 TL60M5X13	 T20

注明：配套刀片与株洲钻石、瓦尔特、克洛伊通用。Note: Insert can be Zccct/Walter/Kolory brands.

★ 刀具规格型号 Type of milling tools

Type 型号	基本尺寸(mm) Dimension					Adapter 接口 形式	Tooth 齿数	Weight 重量 (kg)
	ØD ₂	ØD	Ød	H	ap			
PF88.12A22.050.04	40	50	22	40	10	A	4	0.3
PF88.12A22.063.06	50	63	22	40	10	A	6	0.5
PF88.12A27.080.07	60	80	27	50	10	A	7	1.2
PF88.12B32.100.08	70	100	32	50	10	B	8	1.8
PF88.12B40.125.10	80	125	40	63	10	B	10	3.1
PF88.12B40.160.12	100	160	40	63	10	B	12	5.5
PF88.12C60.200.14	160	200	60	63	10	C	14	7.2

了解具体库存情况请致电厂家 详情请登陆网站www.hnsant.com



铣削刀具 | MILLING TOOLS

Indexable milling tools 可转位铣削刀具

★ 刀片选择 Matching Insert

型号 Type	SP210M	SP210T	SD2136	SD2336	SD4326	SD4226	SD4236	SD5346	SD5236	SD5450	SD5440	SD5146	基本尺寸(mm) Dimension				
	L	Ø1.C	S	Ød	r												
SNGX1205PNN	○	○											12.7	12.7	6.5	5.9	0.8
SNMX1205ANN			●	●	○	○	○	○			●		12.7	12.7	6.5	5.9	0.8

P 钢	<input type="checkbox"/>	<input checked="" type="checkbox"/>	<input checked="" type="checkbox"/>	<input checked="" type="checkbox"/>				<input checked="" type="checkbox"/>			<input checked="" type="checkbox"/>						
M 不锈钢	<input type="checkbox"/>	<input type="checkbox"/>	<input type="checkbox"/>	<input checked="" type="checkbox"/>													
K 铸铁	<input checked="" type="checkbox"/>	<input type="checkbox"/>		<input checked="" type="checkbox"/>	<input checked="" type="checkbox"/>	<input checked="" type="checkbox"/>	<input checked="" type="checkbox"/>										
N 有色金属																	
S 耐热合金、钛合金				<input checked="" type="checkbox"/>													
H 淬硬材料																	

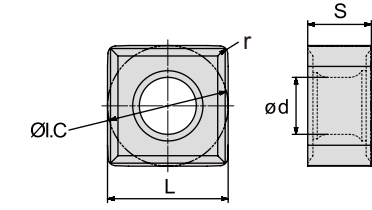

● 常备库存 Unallocated stock ○ 可备库存 Available stock ■ 推荐应用 Main application □ 拓展应用 Extended application

了解具体库存情况请致电厂家 详情请登陆网站www.hnsant.com

可转位铣削刀具 Indexable milling tools

面铣刀具 Kr:90°

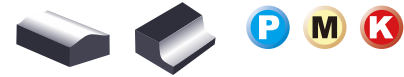

PF01

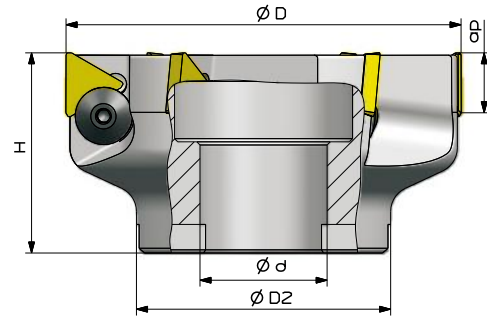

★ 刀具附件 Spare parts

刀片 Insert 	刀片螺钉 Insert Screw 	扳手 Wrench
TPKN2204	MYL8X18	S4

注明：配套刀片建议参考株洲钻石刀片。 Note: The insert is Zccct brand.

★ 刀具规格型号 Type of milling tools

Type 型号	基本尺寸(mm) Dimension					Adapter 接口 形式	Tooth 齿数	Weight 重量 (kg)
	ØD ₂	ØD	Ød	H	a _p			
PF01.22A22.063.03	50	63	22	50	15	A	3	0.5
PF01.22A27.080.04	60	80	27	50	15	A	4	0.9
PF01.22B32.100.05	70	100	32	50	15	B	5	1.8
PF01.22B40.125.06	80	125	40	63	15	B	6	2.5
PF01.22B40.160.07	100	160	40	63	15	B	7	3.6

Indexable milling tools 可转位铣削刀具

面铣刀具 Kr:90°

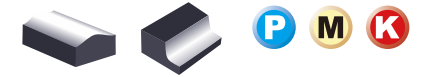

PF02

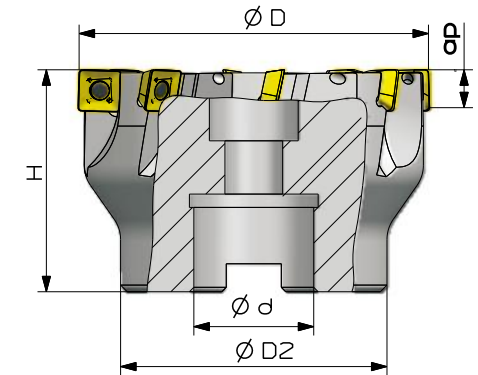

★ 刀具附件 Spare parts

刀片 Insert 	刀片螺钉 Insert Screw 	扳手 Wrench
SEET09T308PER	TL60 M3X7	T08T

注明：配套刀片建议参考株洲钻石刀片。 Note: The insert is Zccct brand.

★ 刀具规格型号 Type of Milling Tools

Type 号 型	基本尺寸(mm) Dimension					Adapter 接口 形式	Tooth 齿数	Weight 重量 (kg)
	ØD ₂	ØD	Ød	H	a _p			
PF02.09A22.050.05	40	50	22	40	6.5	A	5	0.3
PF02.09A22.063.06	50	63	22	40	6.5	A	6	0.5
PF02.09A27.080.08	60	80	27	50	6.5	A	8	0.9
PF02.09B32.100.08	70	100	32	50	6.5	B	8	1.7
PF02.09B32.100.10	70	100	32	50	6.5	B	10	1.7
PF02.09B40.125.12	80	125	40	63	6.5	B	12	2.6

可转位铣削刀具 Indexable milling tools

面铣刀具 Kr:90°

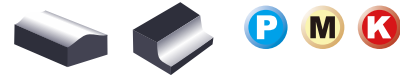

PF02

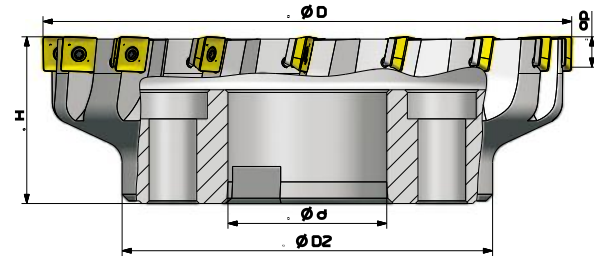

★ 刀具附件 Spare parts

刀片 Insert 	刀垫 Shim 	螺套 Threaded Sleeve 	刀片螺钉 Insert Screw 	扳手 wrench 	扳手 Wrench
SEET120308PER	S12BSX	SM0508	TL60 M3.5X10	T15 T	S3.5

注明：配套刀片建议参考株洲钻石刀片。Note: The insert is Zscct brand.

★ 刀具规格型号 Type of milling tools

Category 类别	Type 型号	基本尺寸(mm) Dimension					Adapter 接口形式	Tooth 齿数	Weight 重量 (kg)
		ØD ₂	ØD	Ød	H	a _p			
疏齿型	PF02.12A22.050.03	40	50	22	40	10	A	3	0.3
	PF02.12A22.063.04	50	63	22	40	10	A	4	0.65
	PF02.12A27.080.04	60	80	27	50	10	A	4	0.9
	PF02.12B32.100.05	70	100	32	50	10	B	5	1.2
	PF02.12B40.125.06	80	125	40	63	10	B	6	3.1
	PF02.12C40.160.08	100	160	40	63	10	C	8	4.1
	PF02.12C60.200.10	140	200	60	63	10	C	10	6.1
	PF02.12C60.250.12	200	250	60	63	10	C	12	10.9
标准型	PF02.12A22.050.04	40	50	22	40	10	A	4	0.3
	PF02.12A22.063.05	50	63	22	40	10	A	5	0.65
	PF02.12A27.080.06	60	80	27	50	10	A	6	0.9
	PF02.12B32.100.07	70	100	32	50	10	B	7	1.2
	PF02.12B40.125.08	80	125	40	63	10	B	8	3.1
	PF02.12C40.160.12	100	160	40	63	10	C	12	4.1

Indexable milling tools 可转位铣削刀具

面铣刀具 Kr:90°

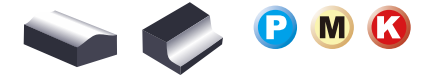

★ 刀具规格型号 Spare parts

Category 类别	Type 型号	基本尺寸(mm) Dimension					Adapter 接口形式	Tooth 齿数	Weight 重量 (kg)
		ØD ₂	ØD	Ød	H	a _p			
密齿型	PF02.12A22.050.05	40	50	22	40	10	A	5	0.3
	PF02.12A22.063.06	50	63	22	40	10	A	6	0.65
	PF02.12A27.080.08	60	80	27	50	10	A	8	0.9
	PF02.12B32.100.10	70	100	32	50	10	B	10	1.2
	PF02.12B40.125.12	80	125	40	63	10	B	12	3.1
	PF02.12C40.160.14	100	160	40	63	10	C	14	4.1
	PF02.12C60.200.16	140	200	60	63	10	C	16	6.1
	PF02.12C60.250.18	200	250	60	63	10	C	18	10.9
	PF02.12D60.315.24	250	315	60	63	10	D	24	21.6

可转位铣削刀具 Indexable milling tools

面铣刀具 Kr:90°

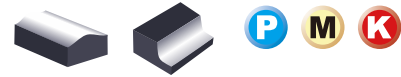

PF03

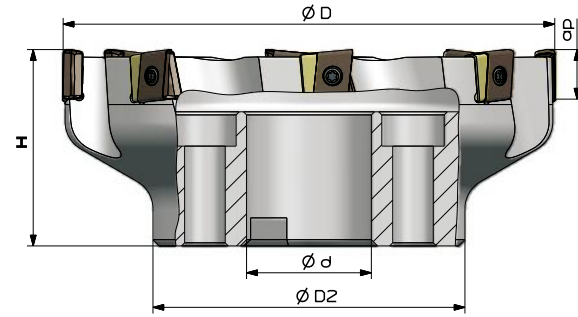

★ 刀具附件 Spare parts

刀片 Insert	刀垫 Shim	刀片螺钉 Insert Screw	刀垫螺钉 Shim Screw	扳手 Wrench	扳手 Wrench
LNKT1506EN-ZR	LLN15-ZR	TL60 M4X12	L60 M3X7	T15T	T10T
LNKT2007DN-ZR	LLN20-ZR	TL60 M4X15	L60 M3X7	T15T	T10T
LNKT2510-ZR	LLN25R-ZR	TL60 M5X17	L60 M3.5X10	T15T	T20T

注明：配套刀片建议参考株洲钻石品牌刀片。Note: The insert is Zscct brand

★ 刀具规格型号 Type of milling tools

Category 类别	Type 型号	基本尺寸(mm) Dimension					Adapter 接口形式	Tooth 齿数	Weight 重量 (kg)
		$\varnothing D_2$	$\varnothing D$	$\varnothing d$	H	ap			
LN15	PF03.15B40.125.06	80	125	40	63	8	B	6	3.2
	PF03.15C40.160.08	100	160	40	63	8	C	8	5.1
	PF03.15C60.200.10	150	200	60	63	8	C	10	6.5
	PF03.15C60.250.12	200	250	60	63	8	C	12	11.5
	PF03.15D60.315.16	250	315	60	63	8	D	16	19.8

Indexable milling tools 可转位铣削刀具

面铣刀具 Kr:90°

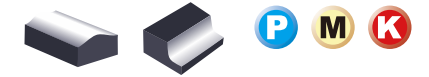

★ 刀具规格型号 Spare parts

Category 类别	Type 型号	基本尺寸(mm) Dimension					Adapter 接口形式	Tooth 齿数	Weight 重量 (kg)
		$\varnothing D_2$	$\varnothing D$	$\varnothing d$	H	ap			
LN20	PF03.20B40.125.06	80	125	40	63	12	B	6	3.2
	PF03.20C40.160.08	100	160	40	63	12	C	8	5.1
	PF03.20C60.200.10	150	200	60	63	12	C	10	6.5
	PF03.20C60.250.12	200	250	60	63	12	C	12	11.5
	PF03.20D60.315.15	250	315	60	63	12	D	15	19.8
LN25	PF03.25B40.125.05	80	125	40	63	15	B	5	3.2
	PF03.25C40.160.06	100	160	40	63	15	C	6	5.1
	PF03.25C60.200.08	150	200	60	63	15	C	8	6.5
	PF03.25C60.250.10	200	250	60	63	15	C	10	11.5
	PF03.25D60.315.12	250	315	60	63	15	D	12	19.8

面铣刀具 Kr:90°

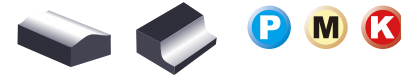

PF04

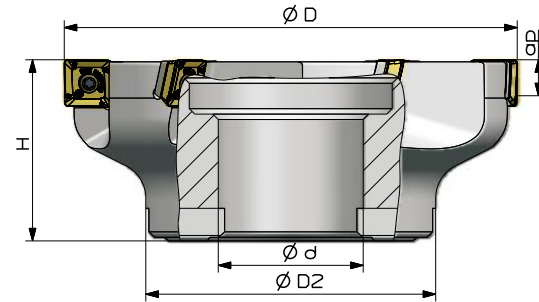

★ 刀具附件 Spare parts

刀片 Insert 	刀垫 Shim 	螺套 Threaded Sleeve 	刀片螺钉 Insert Screw 	扳手 Wrench 	扳手 Wrench
R290-12T308	S12BSX	SM0508	TL60 M3.5X10	T15T	S3.5

注明：配套刀片建议参考山特维克品牌刀片。Note: The insert is Sandvik brand.

★ 刀具规格型号 Type of milling tools

Type 型号	基本尺寸(mm) Dimension					Adapter 接口 形式	Tooth 齿数	Weight 重量 (kg)
	ØD ₂	ØD	Ød	H	a _p			
PF04.12A22.050.03	40	50	22	40	9	A	3	0.5
PF04.12A22.063.04	50	63	22	40	9	A	4	0.6
PF04.12B27.080.04	60	80	27	50	9	B	4	0.9
PF04.12B32.100.05	70	100	32	50	9	B	5	1.3
PF04.12B40.125.06	80	125	40	63	9	B	6	2.7
PF04.12C40.160.08	100	160	40	63	9	C	8	4.1
PF04.12C60.200.10	150	200	60	63	9	C	10	6.2
PF04.12C60.250.12	180	250	60	63	9	C	12	10.7

面铣刀具 Kr:90°

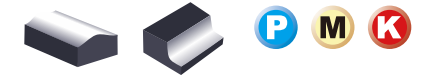

PF06

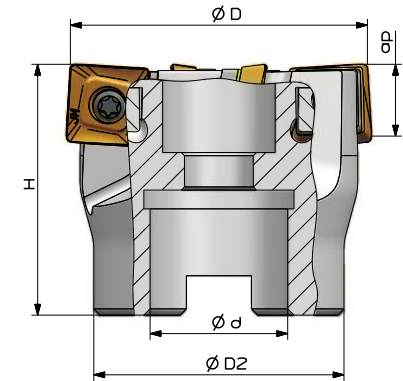

★ 刀具附件 Spare parts

刀片 Insert 	刀垫 Shim 	螺套 Threaded Sleeve 	刀片螺钉 Insert Screw 	扳手 Wrench 	扳手 Wrench
SOMT12T308PEER	S12BSX	SM0508	TL60 M3.5X10	T15T	S3.5

注明：配套刀片建议参考三菱品牌刀片。Note: The insert is Mitsubishi brand.

★ 刀具规格型号 Type of milling tools

Type 型号	基本尺寸(mm) Dimension					Adapter 接口 形式	Tooth 齿数	Weight 重量 (kg)
	ØD ₂	ØD	Ød	H	a _p			
PF06.12A22.050.04	40	50	22	40	10	A	4	0.3
PF06.12A22.063.05	50	63	22	40	10	A	5	0.5
PF06.12B27.080.06	60	80	27	50	10	B	6	0.6
PF06.12B32.100.07	70	100	32	50	10	B	7	1.4
PF06.12B40.125.08	80	125	40	63	10	B	8	2.2
PF06.12C40.160.12	100	160	40	63	10	C	12	3.5
PF06.12C60.200.16	150	200	60	63	10	C	16	6.2
PF06.12C60.250.18	180	250	60	63	10	C	18	10.7

可转位铣削刀具 Indexable milling tools

面铣刀具 Kr:90°

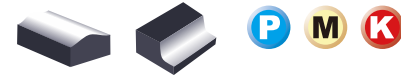

PF07

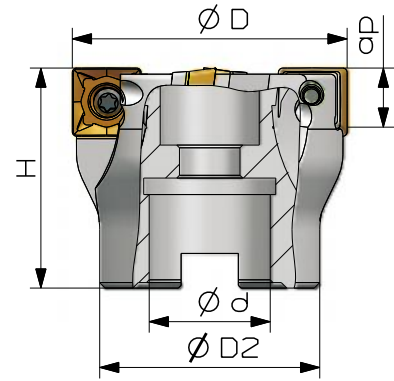

★ 刀具附件 Spare parts

刀片 Insert 	刀垫 Shim 	螺套 Threaded Sleeve 	刀片螺钉 Insert Screw 	扳手 Wrench 	扳手 Wrench
XDMT120408PDER	S12BSX	SM0508	TL60 M3.5X10	T15T	S3.5

注明：配套刀片建议参考住友品牌刀片。Note: The insert is Sumitomo brand.

★ 刀具规格型号 Type of Milling Tools

Type 型号	基本尺寸(mm) Dimension					Adapter 接口 形式	Tooth 齿数	Weight 重量 (kg)
	ØD ₂	ØD	Ød	H	ap			
PF07.12A22.050.04	40	50	22	40	10	A	4	0.3
PF07.12A22.063.05	50	63	22	40	10	A	5	0.5
PF07.12A27.080.06	60	80	27	50	10	A	6	1.0
PF07.12B32.100.07	70	100	32	50	10	B	7	1.5
PF07.12B40.125.08	80	125	40	63	10	B	8	2.5
PF07.12C40.160.10	100	160	40	63	10	C	10	4.5
PF07.12C60.200.12	150	200	60	63	10	C	12	8.3

了解具体库存情况请致电厂家 详情请登陆网站www.hnsant.com

Indexable milling tools 可转位铣削刀具

面铣刀具 Kr:90°

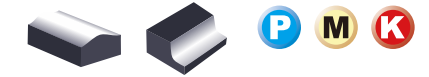

PF08

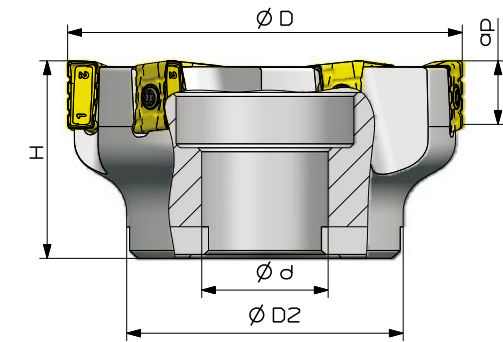

★ 刀具附件 Spare parts

刀片 Insert 	刀片螺钉 Insert Screw 	扳手 Wrench
LNMX170808PNSR	TL60 M4X12	T15T

注明：配套刀片建议参考住友品牌刀片。Note: The insert is Sumitomo brand.

★ 刀具规格型号 Type of milling tools

Type 型号	基本尺寸(mm) Dimension					Adapter 接口 形式	Tooth 齿数	Weight 重量 (kg)
	ØD ₂	ØD	Ød	H	ap			
PF08.17B27.080.05	60	80	27	50	14	B	5	1.0
PF08.17B32.100.06	70	100	32	50	14	B	6	1.8
PF08.17B40.125.06	80	125	40	63	14	B	6	2.4
PF08.17B40.160.08	100	160	40	63	14	B	8	4.0
PF08.17C60.200.10	150	200	60	63	14	C	10	6.5
PF08.17C60.250.12	180	250	60	63	14	C	12	12.3

了解具体库存情况请致电厂家 详情请登陆网站www.hnsant.com

铣削刀具 | MILLING TOOLS



可转位铣削刀具 Indexable milling tools

面铣刀具 Kr:90°

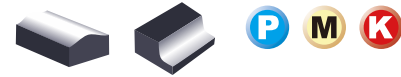

PF09

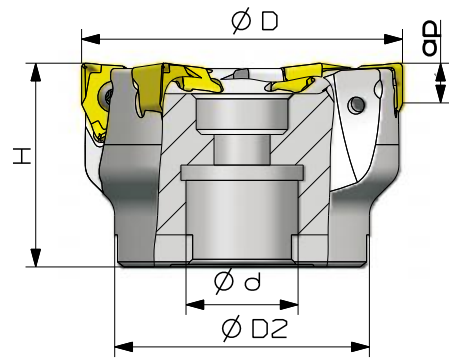

★ 刀具附件 Spare parts

刀片 Insert 	刀片螺钉 Insert Screw 	扳手 Wrench
XNEX0806	TL60 M4X12	T15T

注明：配套刀片建议参考山高品牌刀片。Note: The insert is SECO brand.

★ 刀具规格型号 Type of Milling Tools

Type 型号	基本尺寸(mm) Dimension					Adapter 接口 形式	Tooth 齿数	Weight 重量 (kg)
	ØD ₂	ØD	Ød	H	ap			
PF09.08A22.050.05	40	50	22	40	6	A	5	0.3
PF09.08A22.063.06	50	63	22	40	6	A	6	0.5
PF09.08B27.080.07	60	80	27	50	6	B	7	1.0
PF09.08B32.100.08	70	100	32	50	6	B	8	1.8
PF09.08B40.125.11	80	125	40	63	6	B	11	2.4
PF09.08B40.160.12	100	160	40	63	6	B	12	3.8
PF09.08C60.200.16	150	200	60	63	6	C	16	6.2

了解具体库存情况请致电厂家 详情请登陆网站www.hnsant.com



铣削刀具 | MILLING TOOLS

可转位铣削刀具 Indexable milling tools

面铣刀具 Kr:90°

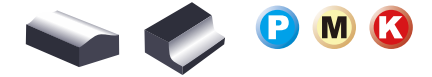

PF10

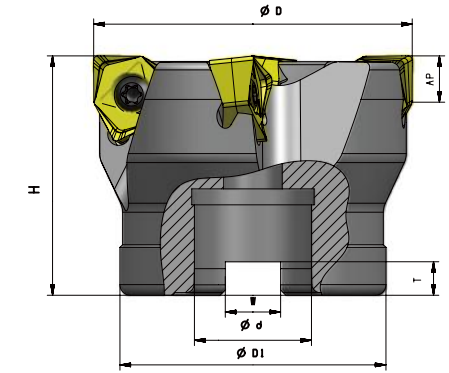

★ 刀具附件 Spare parts

刀片 Insert 	刀片螺钉 Insert Screw 	扳手 Wrench
WNMU080608	TL60 M5X13	T20T

注明：配套刀片与京瓷品牌通装。Note: Replaceable with Kyocera brand inserts.

★ 刀具规格型号 Type of Milling Tools

Type 型号	基本尺寸(mm) Dimension							Adapter 接口 形式	Tooth 齿数	Weight 重量 (kg)
	ØD	ØD ₁	Ød	H	W	ap	T			
PF10.08A22.063.03	63	47	22	40	10.4	8	6.3	A	3	0.5
PF10.08A27.080.04	80	60	27	50	12.4	8	6.3	A	4	1.0
PF10.08B32.100.05	100	70	32	50	14.4	8	8	B	5	1.3
PF10.08B40.125.06	125	80	40	63	16.4	8	9	B	6	2.5
PF10.08B40.160.08	160	100	40	63	16.4	8	9	B	8	3.8
PF10.08C60.200.10	200	150	60	63	25.7	8	14	C	10	6.0
PF10.08C60.250.12	250	180	60	63	25.7	8	14	C	12	8.4
PF10.08A22.063.04	63	47	22	40	10.4	8	6.3	A	4	0.5
PF10.08A27.080.05	80	60	27	50	12.4	8	6.3	A	5	1.0
PF10.08B32.100.07	100	70	32	50	14.4	8	8	B	7	1.3
PF10.08B40.125.08	125	80	40	63	16.4	8	9	B	8	2.5
PF10.08B40.160.10	160	100	40	63	16.4	8	9	B	10	3.8
PF10.08C60.200.12	200	150	60	63	25.7	8	14	C	12	6.0
PF10.08C60.250.14	250	180	60	63	25.7	8	14	C	14	8.4

了解具体库存情况请致电厂家 详情请登陆网站www.hnsant.com

铣削刀具 | MILLING TOOLS



可转位铣削刀具 Indexable milling tools

★ 刀片选择 Matching Insert

型号 Type	SP210M	SD2136	SD2336	SD4326	SD4226	SD4236	SD5346	SD5236	SD5450	SD5440	SD5146	基本尺寸(mm) Dimension				
												L	ØI.C	S	Ød	r
WNMU080608PN-GM	●											8.7	14.02	6.65	6.2	0.8
WNMU080608EN-GM	●	●	○	○	○				○	○		8.7	14.02	6.65	6.2	0.8

P 钢	<input type="checkbox"/>	<input checked="" type="checkbox"/>	<input checked="" type="checkbox"/>					<input checked="" type="checkbox"/>	<input checked="" type="checkbox"/>							
M 不锈钢	<input type="checkbox"/>	<input type="checkbox"/>	<input checked="" type="checkbox"/>					<input checked="" type="checkbox"/>								
K 铸铁	<input checked="" type="checkbox"/>	<input checked="" type="checkbox"/>	<input checked="" type="checkbox"/>	<input checked="" type="checkbox"/>	<input checked="" type="checkbox"/>	<input checked="" type="checkbox"/>										
N 有色金属																
S 耐热合金、钛合金			<input checked="" type="checkbox"/>													
H 淬硬材料																

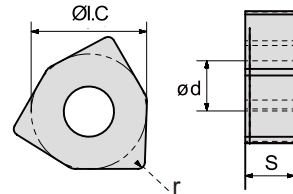

● 常备库存 Unallocated stock ○ 可备库存 Available stock ■ 推荐应用 Main application □ 拓展应用 Extended application



铣削刀具 | MILLING TOOLS

Indexable milling tools 可转位铣削刀具

面铣刀具 Kr:90°

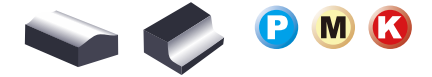

PF11

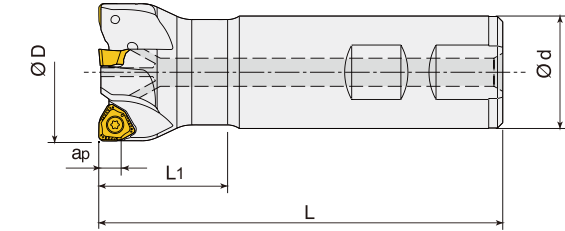

★ 刀具附件 Spare parts

刀片 Insert	刀片螺钉 Insert Screw	扳手 Wrench
XNGU090508PRHDE	TL60 M4X10	T20

注明：配套刀片与株洲钻石、特固克通用。Note: Replaceable with Zccct/Taegutec brand inserts.

★ 刀具规格型号 Type of Milling Tools

Type 型号	基本尺寸(mm) Dimension					Adapter 接口形式	Tooth 齿数	Weight 重量 (kg)
	ØD	Ød	L	L1	ap			
PF11.09Z32.032.02	32	32	160	40	9.2	Z	2	0.3
PF11.09Z32.040.03	40	32	200	40	9.2	Z	3	0.4
PF11.09W32.032.02	32	32	110	40	9.2	W	2	0.3
PF11.09W32.040.03	40	32	120	40	9.2	W	3	0.4
PF11.09W32.040.04	40	32	120	40	9.2	W	4	0.5

可转位铣削刀具 Indexable milling tools

面铣刀具 **Kr:90°**

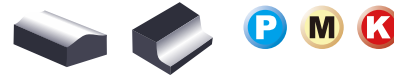

PF11

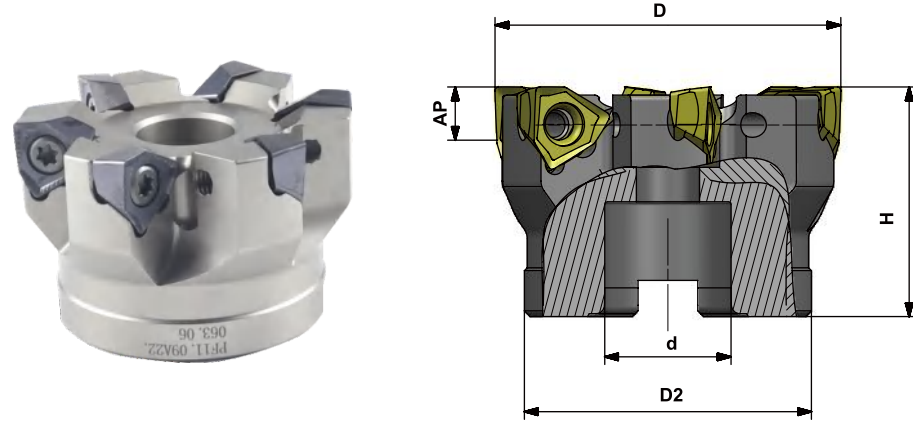

★ 刀具附件 Spare parts

刀片 Insert	刀片螺钉 Insert Screw	扳手 Wrench
XNGU090508PRHDE	TL60 M4X10	T20

注明：配套刀片与株洲钻石、特固克通用。Note: Replaceable with Zscct/Taegutec brand inserts.

★ 刀具规格型号 Type of milling tools

Type 型号	基本尺寸(mm) Dimension					Adapter 接口 形式	Tooth 齿数	Weight 重量 (kg)
	ØD ₂	ØD	ød	H	ap			
PF11.09A22.050.05	40	50	22	40	9.2	A	5	0.35
PF11.09A22.063.06	50	63	22	40	9.2	A	6	0.51
PF11.09A27.080.07	60	80	27	50	9.2	A	7	1.05
PF11.09B32.100.08	70	100	32	50	9.2	B	8	1.82
PF11.09B40.125.11	80	125	40	63	9.2	B	11	3.09
PF11.09B40.160.12	100	160	40	63	9.2	B	12	4.27

Indexable milling tools 可转位铣削刀具

★ 刀片选择 Matching Insert

型号 Type	SP210T	SD2136	SD2336	SD4326	SD4226	SD4236	SD5346	SD5450	SD5440	基本尺寸(mm) Dimension				
										d	t	a	r	ap
XNGU090508PRHDE-M	●									13.05	6.74	2.0	0.8	9.2
P 钢	■													
M 不锈钢	□													
K 铸铁	□													
N 有色金属														
S 耐热合金、钛合金														
H 淬硬材料														

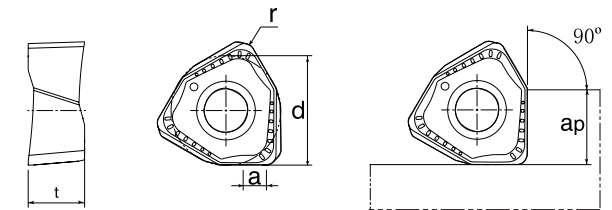

● 常备库存 Unallocated stock ○ 可备库存 Available stock ■ 推荐应用 Main application □ 拓展应用 Extended application

面铣刀具

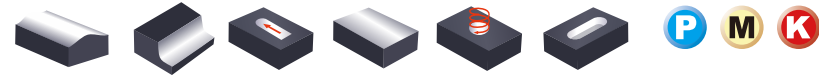

RF01

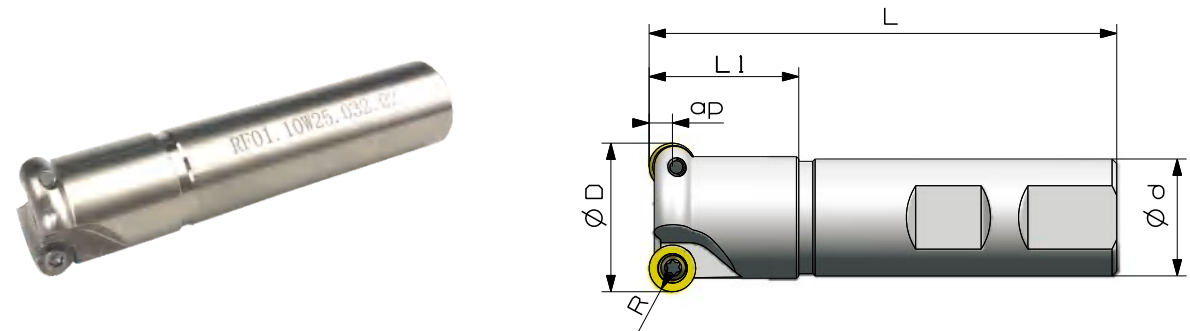

★ 刀具附件 Spare parts

刀片 Insert	刀片螺钉 Insert Screw	扳手 Wrench
RCKT10T3MO-DM	TL60 M4X10	T15
RCKT1204MO-DR	TL60 M3.5X10	T15

注明：配套刀片建议参考株洲钻石品牌刀片。 Note: The insert is Zccct brand.

★ 刀具规格型号 Type of milling tools

Type 型号	基本尺寸(mm) Dimension						Adapter 接口形式	Tooth 齿数	Weight 重量 (kg)
	R	ØD	Ød	L	L1	ap			
RF01.10W20.025.02	5	25	20	100	30	5	W	2	0.2
RF01.10W25.032.02	5	32	25	120	35	5	W	2	0.5
RF01.12W32.040.03	6	40	32	120	40	6	W	3	0.7
RF01.12W32.050.03	6	50	32	120	40	6	W	3	0.8

面铣刀具

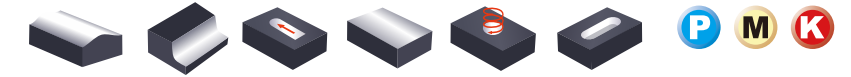

RF01

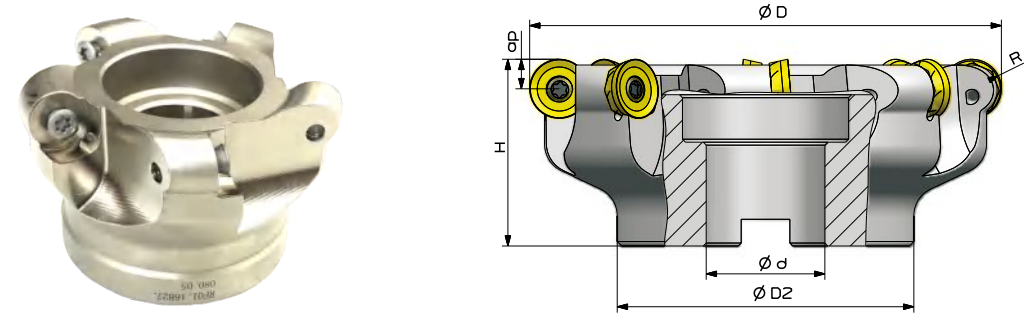

★ 刀具附件 Spare parts

刀片 Insert	刀片螺钉 Insert Screw	扳手 Wrench
RCKT1204MO-DR	TL60 M3.5X10	T15T
RCKT1606MO-DR	TL60 M5X12	T20T
RCKT2006MO-DR	TL60 M6X16	T25T

注明：配套刀片建议参考株洲钻石品牌刀片。 Note: The insert is Zccct brand.

★ 刀具规格型号 Type of Milling Tools

Type 型号	基本尺寸(mm) Dimension						Adapter 接口形式	Tooth 齿数	Weight 重量 (kg)
	R	ØD	Ød	H	ØD2	ap			
RF01.12A22.063.04	6	63	22	50	50	6	A	4	0.7
RF01.16B27.080.05	8	80	27	50	60	8	B	5	0.7
RF01.16B32.100.06	8	100	32	50	70	8	B	6	1.2
RF01.20B40.125.07	10	125	40	63	80	10	B	7	2.2
RF01.20B40.160.08	10	160	40	63	100	10	B	8	4.2

铣削刀具 | MILLING TOOLS



可转位铣削刀具 Indexable milling tools

面铣刀具

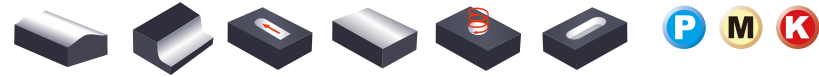

RF02

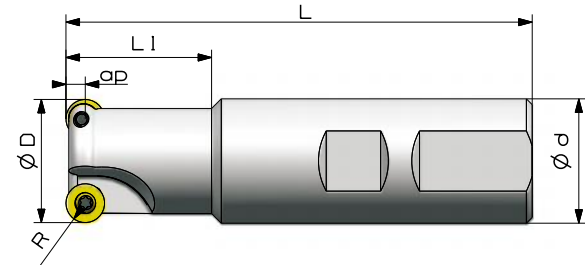

★ 刀具附件 Spare parts

刀片 Insert	刀片螺钉 Insert Screw	扳手 Wrench
RDKW0803MO	TL60 M3X7	T10
RDKW10T3MO	TL60 M4X10	T15
RDKW1204MO	TL60 M4X10	T15

注明：配套刀片建议参考株洲钻石品牌刀片。 Note: The insert is Zccct brand.

★ 刀具规格型号 Type of milling tools

Type 型号	基本尺寸(mm) Dimension						Adapter 接口 形式	Tooth 齿数	Weight 重量 (kg)
	R	ØD	Ød	L	L1	ap			
RF02.08W16.016.02	4	16	16	100	25	4	W	2	0.1
RF02.08W25.025.02	4	25	25	100	30	4	W	2	0.3
RF02.10W32.032.02	5	32	32	120	40	5	W	2	0.7
RF02.12W32.040.03	6	40	32	120	40	6	W	3	0.7
RF02.12W32.050.04	6	50	32	120	40	6	W	4	0.8

了解具体库存情况请致电厂家 详情请登陆网站www.hnsant.com



铣削刀具 | MILLING TOOLS

可转位铣削刀具 Indexable milling tools

面铣刀具

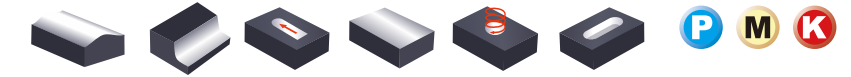

RF02

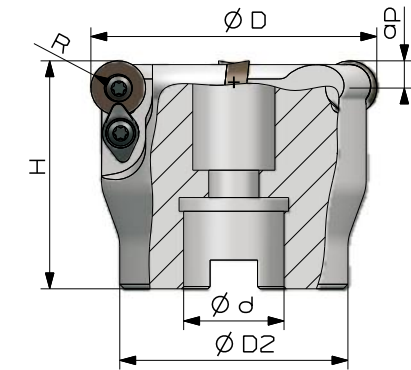

★ 刀具附件 Spare parts

刀片 Insert	刀片螺钉 Insert Screw	压板 Clamp	扳手 Wrench
RDKW1204MO	TL60 M4X10	WD204	T15T
RDKW1605MO	TL60 M5X12	WD208	T20T
RDKW2006MO	TL60 M6X16		T25T

注明：配套刀片建议参考株洲钻石刀片。 Note: The insert is Zccct brand.

★ 刀具规格型号 Type of Milling Tools

Type 型号	基本尺寸(mm) Dimension						Adapter 接口 形式	Tooth 齿数	Weight 重量 (kg)
	R	ØD	Ød	H	ØD ₂	ap			
RF02.12A22.050.03	6	50	22	40	40	6	A	3	0.3
RF02.12A22.063.04	6	63	22	50	50	6	A	4	0.5
RF02.16B27.080.05	8	80	27	50	60	8	B	5	1.2
RF02.16B32.100.06	8	100	32	50	70	8	B	6	1.6
RF02.20B40.125.06	10	125	40	63	80	10	B	6	1.9
RF02.20B40.160.07	10	160	40	63	100	10	B	7	3.7

了解具体库存情况请致电厂家 详情请登陆网站www.hnsant.com

面铣刀具

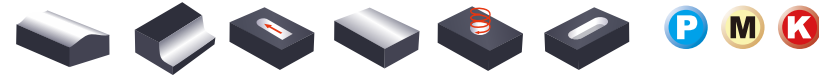

RF03

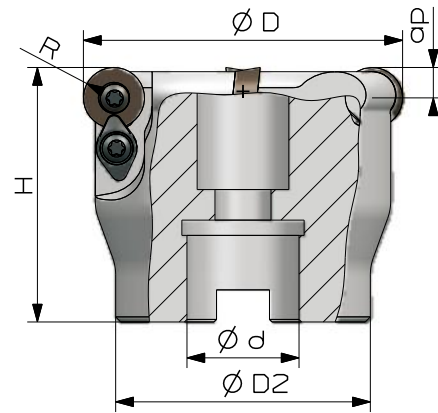

★ 刀具附件 Spare parts

刀片 Insert	刀片螺钉 Insert Screw	压板 Clamp	扳手 Wrench
RPMT1204MO	TL60 M4X10	WD204	T15T
RPMT1606MO	TL60 M5X12	WD208	T20T

注明：配套刀片建议参考三菱品牌刀片。Note: The insert is Mitsubishi brand.

★ 刀具规格型号 Type of milling tools

Category 类别	Type 型号	基本尺寸(mm) Dimension						Adapter 接口形式	Tooth 齿数	Weight 重量 (kg)
		R	ØD	Ød	H	ØD2	ap			
RP12	RF03.12A22.050.04	6	50	22	40	40	6	A	4	0.4
	RF03.12A22.063.05	6	63	22	45	50	6	A	5	0.7
	RF03.12B27.080.06	6	80	27	50	60	6	B	6	1.2
RP16	RF03.16A22.063.04	8	63	22	50	40	8	A	4	0.7
	RF03.16A27.080.05	8	80	27	50	60	8	A	5	1.2
	RF03.16B32.100.06	8	100	32	63	70	8	B	6	1.6

面铣刀具

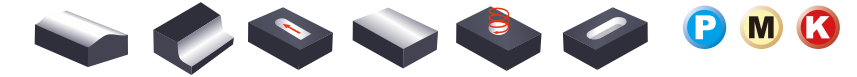

RF04

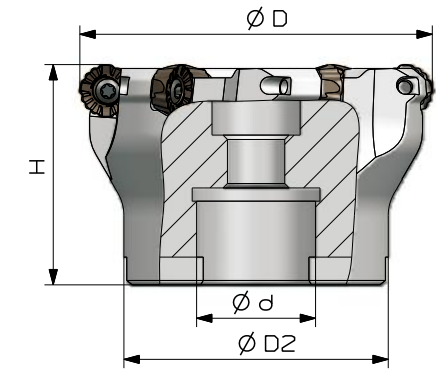
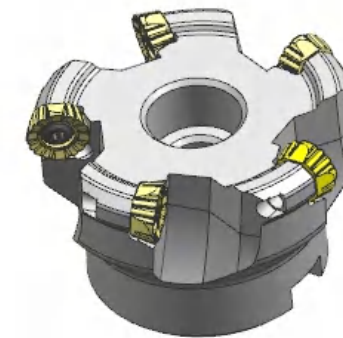

★ 刀具附件 Spare parts

刀片 Insert	刀片螺钉 Insert Screw	扳手 Wrench
QPMT120440	TL60 M4X10	T15T

注明：配套刀片建议参考住友品牌刀片。Note: The insert is Sumitomo brand.

★ 刀具规格型号 Type of Milling Tools

Type 型号	基本尺寸(mm) Dimension				Adapter 接口形式	Tooth 齿数	Weight 重量 (kg)
	ØD2	ØD	Ød	H			
RF04.12A22.050.04	40	50	22	40	A	4	0.2
RF04.12A22.050.05	40	50	22	40	A	5	0.2
RF04.12A22.063.05	50	63	22	40	A	5	0.4
RF04.12A22.063.06	50	63	22	40	A	6	0.4
RF04.12A27.080.06	60	80	27	50	A	6	0.9

铣削刀具 | MILLING TOOLS



可转位铣削刀具 Indexable milling tools

方肩铣刀 Kr:90°



PE01

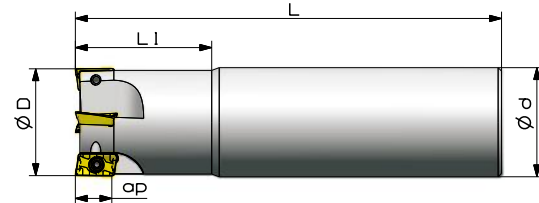

★ 刀具附件 Spare parts

刀片 Insert	刀片螺钉 Insert Screw	扳手 Wrench
APKT11T3□□	TL60 M2.5X6.5	T08
APKT1604□□	TL60 M4X10	T15

★ 刀具规格型号 Type of milling tools

Category 类别	Type 型号	基本尺寸(mm) Dimension					Adapter 接口形式	Tooth 齿数	Weight 重量 (kg)
		ØD	Ød	L	L1	ap			
AP11	PE01.11Z16.012.01	12	16	85	25	10.5	Z	1	0.1
	PE01.11Z16.016.02	16	16	90	25	10.5	Z	2	0.1
	PE01.11Z20.020.02	20	20	100	30	10.5	Z	2	0.2
	PE01.11Z25.025.03	25	25	115	35	10.5	Z	3	0.4
	PE01.11Z32.032.04	32	32	125	40	10.5	Z	4	0.7
	PE01.11W16.012.01	12	16	85	25	10.5	W	1	0.1
	PE01.11W16.016.02	16	16	90	25	10.5	W	2	0.1
	PE01.11W20.020.02	20	20	100	30	10.5	W	2	0.2
	PE01.11W25.025.03	25	25	115	35	10.5	W	3	0.4
	PE01.11W32.032.04	32	32	125	40	10.5	W	4	0.7
AP16	PE01.16Z25.025.02	25	25	115	35	15.5	Z	2	0.4
	PE01.16Z32.032.03	32	32	125	40	15.5	Z	3	0.7
	PE01.16Z32.040.04	40	32	130	42	15.5	Z	4	0.8
	PE01.16W25.025.02	25	25	115	35	15.5	W	2	0.4
	PE01.16W32.032.03	32	32	125	40	15.5	W	3	0.7
	PE01.16W32.040.04	40	32	130	42	15.5	W	4	0.8

了解具体库存情况请致电厂家 详情请登陆网站www.hnsant.com

铣削刀具 | MILLING TOOLS



Indexable milling tools 可转位铣削刀具

方肩铣刀 Kr:90°

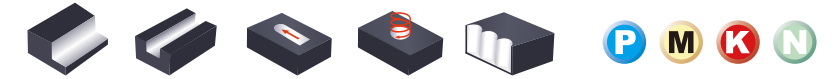

PE01

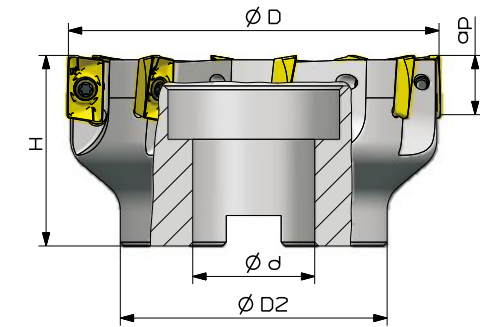
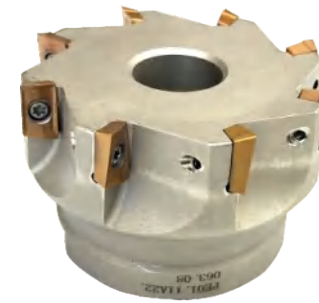

★ 刀具附件 Spare parts

刀片 Insert	刀片螺钉 Insert Screw	扳手 Wrench
APKT11T3□□	TL60 M2.5X6.5	T08
APKT1604□□	TL60 M4X10	T15

★ 刀具规格型号 Type of Milling Tools

Category 类别	Type 型号	基本尺寸(mm) Dimension					Adapter 接口形式	Tooth 齿数	Weight 重量 (kg)
		ØD	Ød	ØD2	H	ap			
AP11	PE01.11A22.050.06	50	22	40	40	11	A	6	0.3
	PE01.11A22.063.08	63	22	50	40	11	A	8	0.6
	PE01.11A27.080.08	80	27	60	50	11	A	8	1.2
	PE01.11B32.100.10	100	32	70	50	11	B	10	1.7
	PE01.16A22.050.05	50	22	40	40	15.5	A	5	0.3
AP16	PE01.16A22.063.06	63	22	50	40	15.5	A	6	0.5
	PE01.16A27.080.07	80	27	60	50	15.5	A	7	1.1
	PE01.16B32.100.08	100	32	70	50	15.5	B	8	1.6
	PE01.16B40.125.10	125	40	80	63	15.5	B	10	3.2
	PE01.16B40.160.10	160	40	100	63	15.5	B	10	6.3

注明：配套刀片建议参考株洲钻石品牌刀片。Note: The Insert Is Zccct brand.

了解具体库存情况请致电厂家 详情请登陆网站www.hnsant.com

铣削刀具 | MILLING TOOLS



可转位铣削刀具 Indexable milling tools

方肩铣刀 Kr:90°

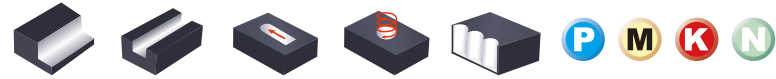

PE02

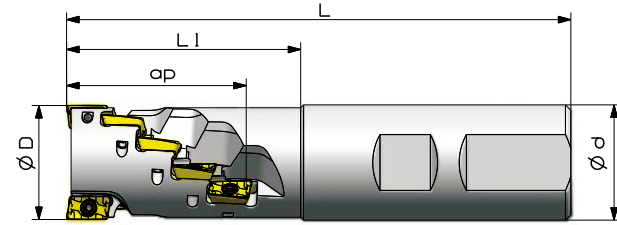

★ 刀具附件 Spare parts

刀片 Insert 	刀片螺钉 Insert Screw 	扳手 Wrench
APKT11T3□□	TL60 M2.5X6.5	T08

注明：配套刀片建议参考株洲钻石品牌刀片。Note: The insert is Zccct brand.

★ 刀具规格型号 Type of milling tools

Type 型号	基本尺寸(mm) Dimension					Adapter 接口 形式	Tooth 齿数	Weight 重量 (kg)
	$\varnothing D$	$\varnothing d$	L	L1	ap			
PE02.11W20.020.01	20	20	120	45	29	W	1	0.3
PE02.11W25.025.02	25	25	130	55	39	W	2	0.4
PE02.11W32.032.02	32	32	140	65	48	W	2	0.7
PE02.11W32.040.02	40	32	150	75	55	W	2	1.3

了解具体库存情况请致电厂家 详情请登陆网站www.hnsant.com



铣削刀具 | MILLING TOOLS

Indexable milling tools 可转位铣削刀具

方肩铣刀 Kr:90°

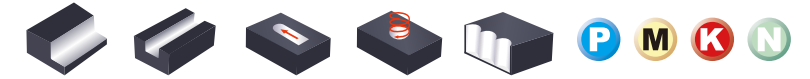

PE02

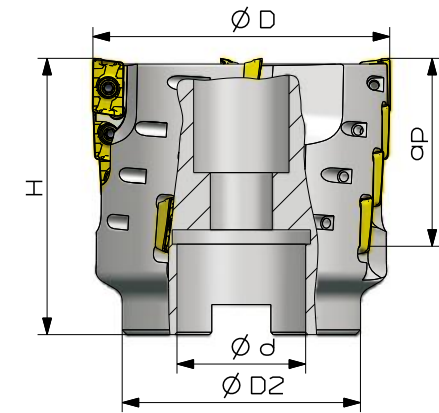

★ 刀具附件 Spare parts

刀片 Insert 	刀片螺钉 Insert Screw 	扳手 Wrench
APKT11T3□□	TL60 M2.5X6.5	T08

注明：配套刀片建议参考株洲钻石品牌刀片。Note: The insert is Zccct brand.

★ 刀具规格型号 Type of Milling Tools

Type 型号	基本尺寸(mm) Dimension					Adapter 接口 形式	Tooth 齿数	Weight 重量 (kg)
	$\varnothing D$	$\varnothing d$	$\varnothing D2$	H	ap			
PE02.11A22.050.04	50	22	40	58	39	A	4	0.5
PE02.11A27.063.04	63	27	50	58	39	A	4	0.9
PE02.11B32.080.05	80	32	60	63	39	B	5	1.3
PE02.11B40.100.06	100	40	70	63	39	B	6	2.0

了解具体库存情况请致电厂家 详情请登陆网站www.hnsant.com

铣削刀具 | MILLING TOOLS



可转位铣削刀具 Indexable milling tools

方肩刀具 Kr:90°

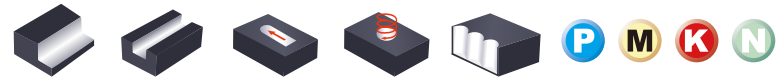

PE03

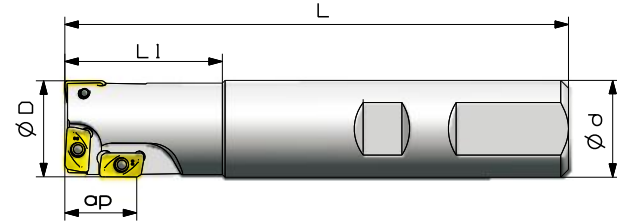
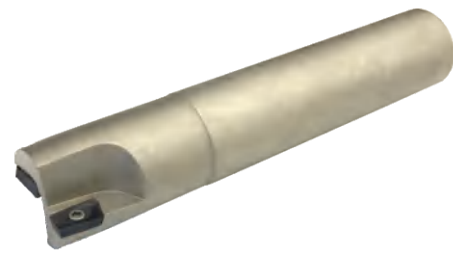

★ 刀具附件 Spare parts

刀片 Insert	刀片螺钉 Insert Screw	扳手 Wrench
APMT113504PDER	TL60 M2.5X6.5	T08
APMT160408PDER	TL60 M4X10	T15

注明：配套刀片建议参考株洲钻石品牌刀片。Note: The insert is Zccct brand.

★ 刀具规格型号 Type of milling tools

Category 类别	Type 型号	基本尺寸(mm) Dimension					Adapter 接口形式	Tooth 齿数	Weight 重量 (kg)
		$\varnothing D$	$\varnothing d$	L	L1	ap			
AP11	PE03.11W25.025	25	25	130	40	20	W	3	0.5
AP16	PE03.16W32.032	32	32	140	50	30	W	3	0.8
	PE03.16W32.040	40	32	150	50	30	W	3	1.0

了解具体库存情况请致电厂家 详情请登陆网站www.hnsant.com



铣削刀具 | MILLING TOOLS

Indexable milling tools 可转位铣削刀具

方肩刀具 Kr:90°

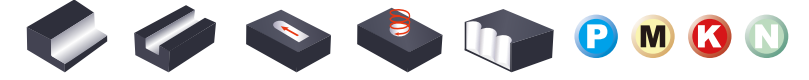

PE04

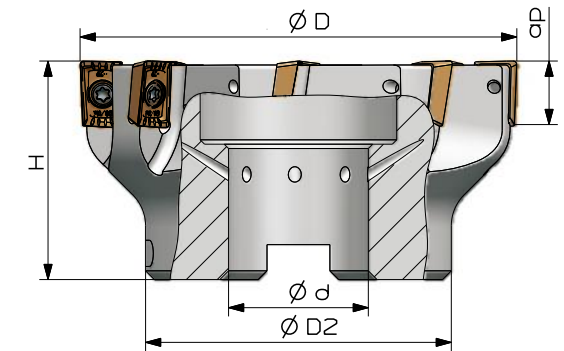

★ 刀具附件 Spare parts

刀片 Insert	刀片螺钉 Insert Screw	扳手 Wrench
LD□□1504□□	TL60 M3.5X12	T15

注明：配套刀片建议参考森拉天时品牌刀片。Note: The insert is Ceratizit brand.

★ 刀具规格型号 Type of Milling Tools

Type 型号	基本尺寸(mm) Dimension					Adapter 接口形式	Tooth 齿数	Weight 重量 (kg)
	$\varnothing D_2$	$\varnothing D$	$\varnothing d$	H	ap			
PE04.15A16.040.04	35	40	16	40	13	A	4	0.3
PE04.15A22.050.05	40	50	22	40	13	A	5	0.5
PE04.15A22.063.06	50	63	22	40	13	A	6	0.9
PE04.15B27.080.07	60	80	27	50	13	B	7	1.7
PE04.15B32.100.08	70	100	32	50	13	B	8	1.7
PE04.15B40.125.10	80	125	40	63	13	B	10	2.6
PE04.15B40.160.12	100	160	40	63	13	B	12	3.5

了解具体库存情况请致电厂家 详情请登陆网站www.hnsant.com

铣削刀具 | MILLING TOOLS



可转位铣削刀具 Indexable milling tools

方肩刀具 Kr:90°

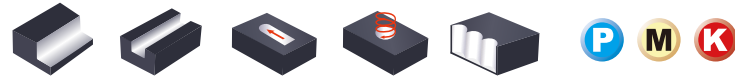

PE05



★ 刀具附件 Spare parts

刀片 Insert 	刀片螺钉 Insert Screw 	扳手 Wrench
APKT1705PER	TL60 M4X10	T15

注明：配套刀片建议参考特固克品牌刀片。Note: The insert is Taegutec brand.

★ 刀具规格型号 Type of milling tools

Type 型号	基本尺寸(mm) Dimension					Adapter 接口 形式	Tooth 齿数	Weight 重量 (kg)
	ØD	Ød	L	L1	ap			
PE05.17W25.025.02	25	25	100	35	14	W	2	0.3
PE05.17Z25.025.02	25	25	200	45	14	Z	2	0.5
PE05.17W32.032.03	32	32	110	40	14	W	3	1.2
PE05.17Z32.032.03	32	32	200	45	14	Z	3	1.8
PE05.17W32.040.04	40	32	115	45	14	W	4	2.4
PE05.17Z32.040.04	40	32	250	45	14	Z	4	3.2

了解具体库存情况请致电厂家 详情请登陆网站www.hnsant.com



铣削刀具 | MILLING TOOLS

Indexable milling tools 可转位铣削刀具

方肩刀具 Kr:90°

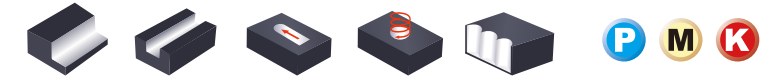

PE05

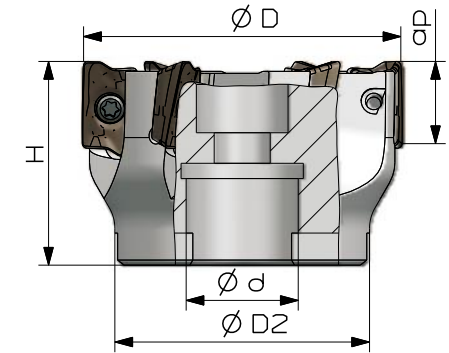

★ 刀具附件 Spare parts

刀片 Insert 	刀片螺钉 Insert Screw 	扳手 Wrench
APKT1705PER	TL60 M4X12	T15T

注明：配套刀片建议参考特固克品牌刀片。Note: The insert is Taegutec brand.

★ 刀具规格型号 Type of Milling Tools

Type 型号	基本尺寸(mm) Dimension					Adapter 接口 形式	Tooth 齿数	Weight 重量 (kg)
	ØD ₂	ØD	Ød	H	ap			
PE05.17A16.040.04	35	40	16	40	14	A	4	0.3
PE05.17A22.050.05	40	50	22	40	14	A	5	0.4
PE05.17A22.063.06	50	63	22	40	14	A	6	0.5
PE05.17A27.080.07	60	80	27	50	14	A	7	1.3
PE05.17B32.100.08	70	100	32	50	14	B	8	1.5
PE05.17B40.125.09	80	125	40	63	14	B	9	3.9
PE05.17C40.160.10	100	160	40	63	14	C	10	5.6
PE05.17C60.200.12	150	200	60	63	14	C	12	7.0

了解具体库存情况请致电厂家 详情请登陆网站www.hnsant.com

铣削刀具 | MILLING TOOLS



可转位铣削刀具 Indexable milling tools

方肩刀具 Kr:90°

PE06

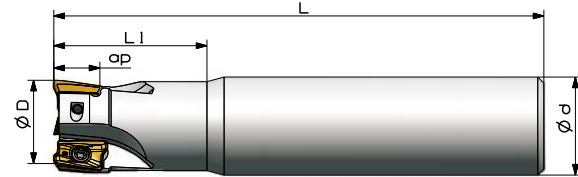

★ 刀具附件 Spare parts

刀片 Insert	刀片螺钉 Insert Screw	扳手 Wrench
AXMT1235□□PEER	TL60 M3X7	T08
AXMT1705□□PEER	TL60 M4X10	T15

注明：配套刀片建议参考住友品牌刀片。Note: The insert is Sumitomo brand.

★ 刀具规格型号 Type of milling tools

Category 类别	Type 型号	基本尺寸(mm) Dimension					Adapter 接口形式	Tooth 齿数	Weight 重量 (kg)
		ØD	Ød	L	L1	ap			
AX12	PE06.12Z16.016.02.S	16	16	100	25	10	Z	2	0.3
	PE06.12Z16.016.02.M	16	16	145	25	10	Z	2	0.5
	PE06.12Z20.020.03.S	20	20	110	30	10	Z	3	0.6
	PE06.12Z20.020.03.M	20	20	150	40	10	Z	3	0.8
	PE06.12Z25.025.04.S	25	25	120	35	10	Z	4	1.0
	PE06.12Z25.025.04.M	25	25	170	50	10	Z	4	1.5
	PE06.12Z32.032.05.S	32	32	130	40	10	Z	5	2.0
	PE06.12Z32.032.05.M	32	32	180	60	10	Z	5	2.4
	PE06.12Z32.040.06.S	40	32	150	30	10	Z	6	2.5
	PE06.12Z32.040.06.M	40	32	180	30	10	Z	6	3.2
AX17	PE06.17Z25.025.02.S	25	25	120	35	14	Z	2	1.0
	PE06.17Z25.025.02.M	25	25	170	50	14	Z	2	1.5
	PE06.17Z32.032.03.S	32	32	130	40	14	Z	3	2.0
	PE06.17Z32.032.03.M	32	32	180	60	14	Z	3	2.4
	PE06.17Z32.040.04.S	40	32	170	50	14	Z	4	2.5
	PE06.17Z32.040.04.M	40	32	220	50	14	Z	4	3.2

了解具体库存情况请致电厂家 详情请登陆网站www.hnsant.com



铣削刀具 | MILLING TOOLS

可转位铣削刀具 Indexable milling tools

方肩刀具 Kr:90°

PE06

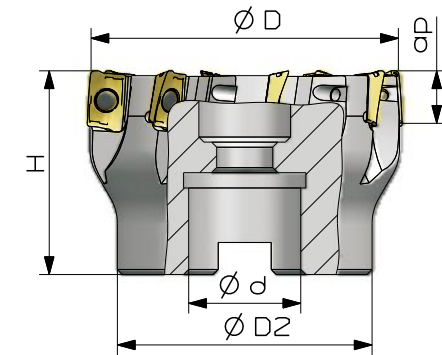

★ 刀具附件 Spare parts

刀片 Insert	刀片螺钉 Insert Screw	扳手 Wrench
AXMT1235□□PEER	TL60 M3X7	T08T
AXMT1705□□PEER	TL60 M4X10	T15T

注明：配套刀片建议参考住友品牌刀片。Note: The insert is Sumitomo brand.

★ 刀具规格型号 Type of Milling Tools

Category 类别	Type 型号	基本尺寸(mm) Dimension					Adapter 接口形式	Tooth 齿数	Weight 重量 (kg)
		ØD	Ød	ØD2	H	ap			
AX12	PE06.12A16.040.06	40	16	35	40	10	A	6	0.3
	PE06.12A22.050.07	50	22	40	40	10	A	7	0.3
	PE06.12A22.063.08	63	22	50	40	10	A	8	0.5
AX17	PE06.17A16.040.04	40	16	35	40	14	A	4	0.3
	PE06.17A22.050.05	50	22	40	40	14	A	5	0.3
	PE06.17A22.063.06	63	22	50	40	14	A	6	0.5
	PE06.17A27.080.07	80	27	60	50	14	A	7	1.7
	PE06.17B32.100.08	100	32	70	50	14	B	8	3.2
PE06.17B40.125.09	125	40	80	63	14	B	9	6.3	

了解具体库存情况请致电厂家 详情请登陆网站www.hnsant.com

铣削刀具 | MILLING TOOLS



可转位铣削刀具 Indexable milling tools

方肩刀具 Kr:90°

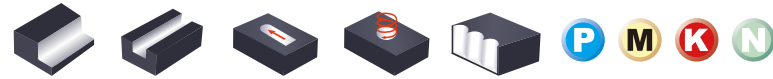

PE07

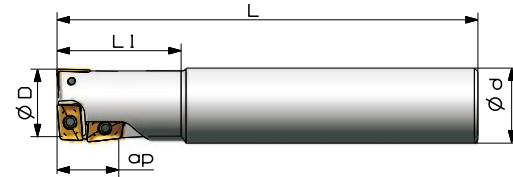

★ 刀具附件 Spare parts

刀片 Insert	刀片螺钉 Insert Screw	扳手 Wrench
APMT1035□□PDER	TL60 M2.5X6.5	T08
APMT1605□□PDER	TL60 M3.5X10	T15

注明：配套刀片建议参考住友品牌刀片。Note: The insert is Sumitomo brand.

★ 刀具规格型号 Type of milling tools

Category 类别	Type 型号	基本尺寸(mm) Dimension					Adapter 接口形式	Tooth 齿数	Weight 重量 (kg)
		ØD	Ød	L	L1	ap			
AP10	PE07.10Z20.020.03.S	20	20	130	35	17	Z	1	0.3
	PE07.10Z20.020.03.M	20	20	185	60	17	Z	1	0.5
	PE07.10Z25.025.04.S	25	25	140	40	26	Z	1	1.2
	PE07.10Z25.025.04.M	25	25	220	75	26	Z	1	1.8
	PE07.10Z25.030.04.S	30	25	150	50	35	Z	1	2.4
	PE07.10Z25.030.04.M	30	25	230	50	35	Z	1	3.2
AP16	PE07.16Z32.032.04.S	32	32	150	50	39	Z	1	0.3
	PE07.16Z32.032.04.M	32	32	230	90	39	Z	1	0.5
	PE07.16Z32.035.04.S	35	32	150	50	39	Z	1	1.2
	PE07.16Z32.035.04.M	35	32	230	50	39	Z	1	1.8
	PE07.16Z32.040.04.S	40	32	160	50	39	Z	1	2.4
	PE07.16Z32.040.04.M	40	32	240	50	39	Z	1	3.2

了解具体库存情况请致电厂家 详情请登陆网站www.hnsant.com



铣削刀具 | MILLING TOOLS

可转位铣削刀具 Indexable milling tools

方肩刀具 Kr:90°

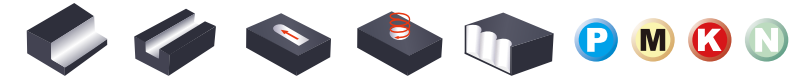

PE08

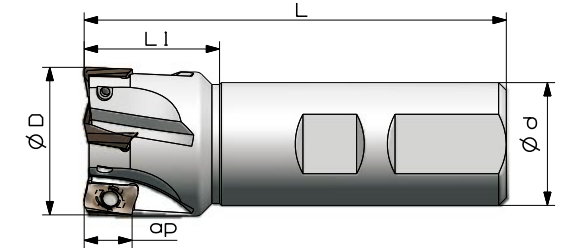

★ 刀具附件 Spare parts

刀片 Insert	刀片螺钉 Insert Screw	扳手 Wrench
ADMT080304R	TL60 M2.5X6.5	T08
ADMT120408R	TL60 M3X8	T10

注明：配套刀片建议参考瓦尔特品牌刀片。Note: The insert is Walter brand.

★ 刀具规格型号 Type of Milling Tools

Category 类别	Type 型号	基本尺寸(mm) Dimension					Adapter 接口形式	Tooth 齿数	Weight 重量 (kg)
		ØD	Ød	L	L1	ap			
AD08	PE08.08W16.016.02	16	16	90	34	8	W	2	0.1
	PE08.08W20.020.03	20	20	90	39	8	W	3	0.2
	PE08.08W25.025.04	25	25	100	43	8	W	4	0.3
	PE08.08W32.032.05	32	32	110	49	8	W	5	0.6
	PE08.08W32.040.06	40	32	110	40	8	W	6	0.7
	PE08.08Z16.016.02	16	16	180	34	8	Z	2	0.3
	PE08.08Z20.020.02	20	20	200	39	8	Z	2	0.5
	PE08.08Z25.025.03	25	25	200	43	8	Z	3	0.7
	PE08.12W25.025.03	25	25	100	43	11.5	W	3	0.35
	PE08.12W32.032.04	32	32	110	49	11.5	W	4	0.6
AD12	PE08.12W32.040.05	40	32	110	40	11.5	W	5	0.7
	PE08.12Z25.025.03	25	25	200	43	11.5	Z	3	0.7
	PE08.12Z32.032.04	32	32	250	49	11.5	Z	4	1.5
	PE08.12Z32.040.05	40	32	250	45	11.5	Z	5	1.6

了解具体库存情况请致电厂家 详情请登陆网站www.hnsant.com

铣削刀具 | MILLING TOOLS



可转位铣削刀具 Indexable milling tools

方肩刀具 Kr:90°



PE08

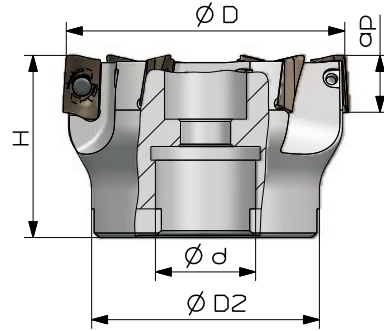

★ 刀具附件 Spare parts

刀片 Insert	刀片螺钉 Insert Screw	扳手 Wrench
ADMT080304R	TL60 M2.5X6.5	T08
ADMT120408R	TL60 M3X8	T10
ADMT160608R	TL60 M4X10	T15

注明：配套刀片建议参考瓦尔特刀片。Note: The insert is Walter brand.

★ 刀具规格型号 Type of milling tools

Category 类别	Type 型号	基本尺寸(mm) Dimension					Adapter 接口形式	Tooth 齿数	Weight 重量 (kg)
		ØD	Ød	ØD2	H	ap			
AD08	PE08.08A16.040.06	40	16	35	40	8	A	6	0.2
	PE08.08A22.050.07	50	22	40	40	8	A	7	0.38
AD12	PE08.12A16.040.05	40	16	35	40	11.5	A	5	0.2
	PE08.12A22.050.06	50	22	40	40	11.5	A	6	0.3
	PE08.12A22.063.07	63	22	50	40	11.5	A	7	0.6
	PE08.12A27.080.08	80	27	60	50	11.5	A	8	1.1
AD16	PE08.16A16.040.04	40	16	35	40	15	A	4	0.2
	PE08.16A22.050.05	50	22	40	40	15	A	5	0.3
	PE08.16A22.063.06	63	22	50	40	15	A	6	0.6
	PE08.16A27.080.07	80	27	60	50	15	A	7	1.0
	PE08.16B32.100.08	100	32	70	50	15	B	8	1.6
	PE08.16B40.125.10	125	40	80	63	15	B	10	3.4
	PE08.16C40.160.12	160	40	100	63	15	C	12	4.3

了解具体库存情况请致电厂家 详情请登陆网站www.hnsant.com



铣削刀具 | MILLING TOOLS

Indexable milling tools 可转位铣削刀具

方肩刀具 Kr:90°

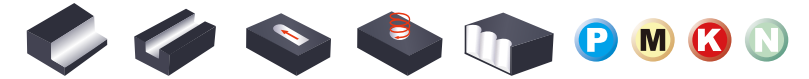

PE09

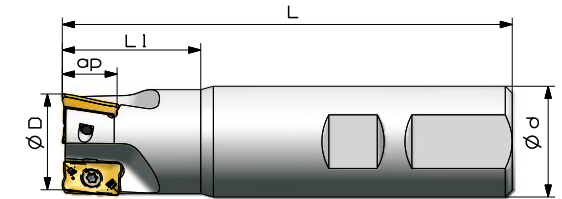

★ 刀具附件 Spare parts

刀片 Insert	刀片螺钉 Insert Screw	扳手 Wrench
R390-11T3□□	TL60 M2.5X6.5	T08
R390-1704□□	TL60 M3.5X10	T15

注明：配套刀片建议参考山特维刀片。Note: The insert is Sandvik brand.

★ 刀具规格型号 Type of Milling Tools

Category 类别	Type 型号	基本尺寸(mm) Dimension					Adapter 接口形式	Tooth 齿数	Weight 重量 (kg)
		ØD	Ød	L	L1	ap			
11	PE09.11Z16.016.02	16	16	100	20	10	Z	2	0.3
	PE09.11Z20.020.02	20	20	110	25	10	Z	2	0.4
	PE09.11Z25.025.03	25	25	120	32	10	Z	3	0.5
	PE09.11Z32.032.03	32	32	130	40	10	Z	3	0.8
	PE09.11Z32.040.04	40	32	170	40	10	Z	4	1.7
	PE09.11W16.016.02	16	16	73	25	10	W	2	0.3
	PE09.11W20.020.02	20	20	81	25	10	W	2	0.4
	PE09.11W25.025.03	25	25	88	32	10	W	3	0.5
	PE09.11W32.032.03	32	32	100	40	10	W	3	0.8
	PE09.11W32.040.04	40	32	110	40	10	W	4	1.7
	17	PE09.17Z25.025.02	25	25	120	32	15.7	Z	2
PE09.17Z32.032.03		32	32	130	40	15.7	Z	3	0.8
PE09.17Z32.040.04		40	32	170	40	15.7	Z	4	0.9
PE09.17W25.025.02		25	25	88	32	15.7	W	2	0.4
PE09.17W32.032.03		32	32	100	40	15.7	W	3	0.8
	PE09.17W32.040.04	40	32	110	40	15.7	W	4	0.9

了解具体库存情况请致电厂家 详情请登陆网站www.hnsant.com

方肩刀具 Kr:90°

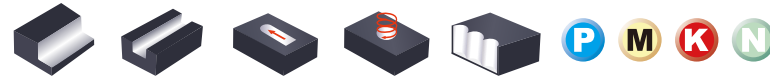

PE09

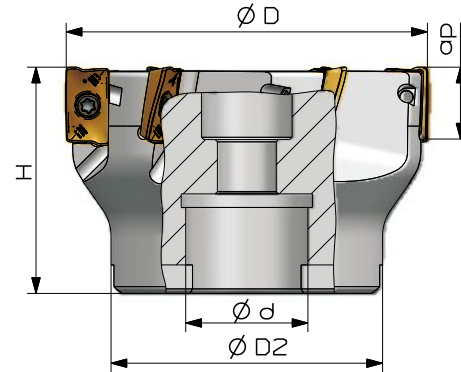

★ 刀具附件 Spare parts

刀片 Insert	刀片螺钉 Insert Screw	扳手 Wrench
R390-11T3□□	TL60 M2.5X6.5	T08
R390-1704□□	TL60 M3.5X10	T15

注明：配套刀片建议参考山特维克品牌刀片。Note:The insert is Sandvik brand.

★ 刀具规格型号 Type of Milling Tools

Category 类别	Type 型号	基本尺寸(mm) Dimension					Adapter 接口形式	Tooth 齿数	Weight 重量(kg)
		ØD	Ød	ØD ₂	H	ap			
11	PE09.11A16.040.04	40	16	35	40	10	A	4	0.4
	PE09.11A22.050.05	50	22	40	40	10	A	5	0.5
	PE09.11A22.063.06	63	22	50	40	10	A	6	0.6
	PE09.11A27.080.07	80	27	60	50	10	A	7	0.9
17	PE09.17A16.040.03	40	16	35	40	15.7	A	3	0.3
	PE09.17A22.050.04	50	22	40	40	15.7	A	4	0.4
	PE09.17A22.063.05	63	22	50	40	15.7	A	5	0.6
	PE09.17A27.080.06	80	27	60	50	15.7	A	6	0.8
	PE09.17B32.100.07	100	32	70	50	15.7	B	7	1.0
	PE09.17B40.125.08	125	40	80	63	15.7	B	8	2.7

方肩刀具 Kr:90°

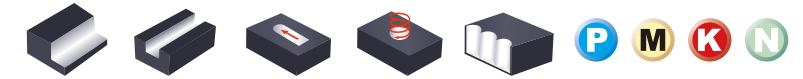

PE10

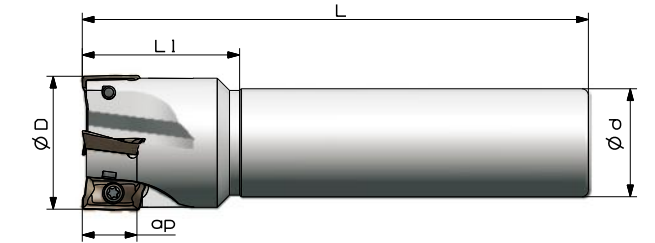

★ 刀具附件 Spare parts

刀片 Insert	刀片螺钉 Insert Screw	扳手 Wrench
BDMT11T3□□ER	TL60 M2.5X6.5	T08
BDMT1704□□ER	TL60 M4X10	T15

注明：配套刀片建议参考京瓷品牌刀片。Note:The insert is Kyocera brand.

★ 刀具规格型号 Type of Milling Tools

Category 类别	Type 型号	基本尺寸(mm) Dimension					Adapter 接口形式	Tooth 齿数	Weight 重量(kg)
		ØD	Ød	L	L1	ap			
11	PE10.11Z16.016.02	16	16	100	30	10	Z	2	0.2
	PE10.11Z20.020.03	20	20	110	32	10	Z	3	0.3
	PE10.11Z25.025.03	25	25	120	32	10	Z	3	0.3
	PE10.11Z32.032.04	32	32	130	40	10	Z	4	0.4
17	PE10.17Z25.025.02	25	25	120	36	15.7	Z	2	0.3
	PE10.17Z32.032.03	32	32	130	40	15.7	Z	3	0.4
	PE10.17Z32.040.04	40	32	150	40	15.7	Z	4	0.5

方肩刀具 Kr:90°

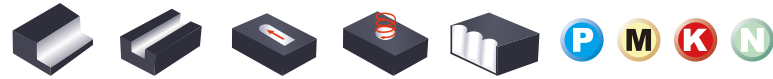

PE10

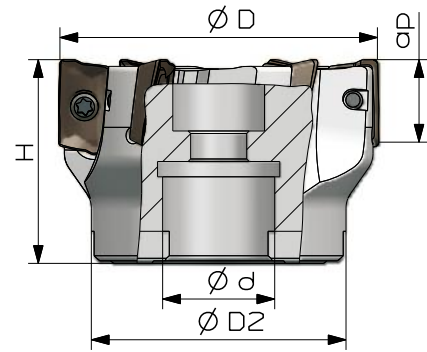
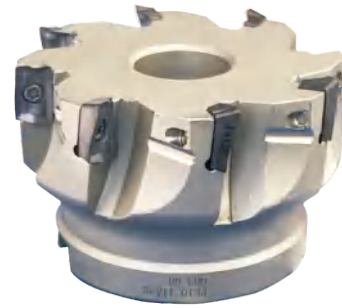

★ 刀具附件 Spare parts

刀片 Insert	刀片螺钉 Insert Screw	扳手 Wrench
BDMT11T3□□ER	TL60 M2.5X6.5	T08
BDMT1704□□ER	TL60 M4X10	T15

注明：配套刀片建议参考京瓷品牌刀片。Note:The insert is Kyocera brand.

★ 刀具规格型号 Type of Milling Tools

Category 类别	Type 型号	基本尺寸(mm) Dimension					Adapter 接口形式	Tooth 齿数	Weight 重量(kg)
		ØD	Ød	ØD2	H	ap			
11	PE10.11A22.050.07	50	22	40	40	10	A	7	0.5
	PE10.11A22.063.08	63	22	50	40	10	A	8	0.6
	PE10.11A27.080.10	80	27	60	50	10	A	10	0.9
17	PE10.17A22.050.05	50	22	40	40	15.7	A	5	0.4
	PE10.17A22.063.06	63	22	50	40	15.7	A	6	0.6
	PE10.17A27.080.08	80	27	60	50	15.7	A	8	0.8
	PE10.17B32.100.09	100	32	70	50	15.7	B	9	1.5

方肩刀具 Kr:90°

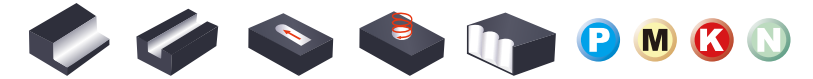

PE11

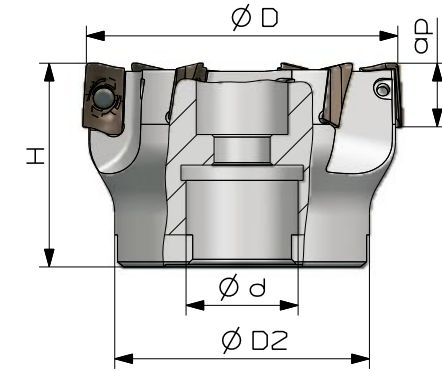

★ 刀具附件 Spare parts

刀片 Insert	刀片螺钉 Insert Screw	扳手 Wrench
APKT100304PDER	TL60 M2.5X6.5	T08

注明：配套刀片建议参考伊斯卡品牌刀片。Note:The insert is Iscar brand.

★ 刀具规格型号 Type of Milling Tools

Category 类别	Type 型号	基本尺寸(mm) Dimension					Adapter 接口形式	Tooth 齿数	Weight 重量(kg)
		ØD	Ød	ØD2	H	ap			
AP10	PE11.10A16.040.05	40	16	35	40	8	A	5	0.2
	PE11.10A22.050.06	50	22	40	40	8	A	6	0.3
	PE11.10A22.063.07	63	22	50	40	8	A	7	0.6
	PE11.10A27.080.08	80	27	60	50	8	A	8	1.1
	PE11.10B32.100.10	100	32	70	50	8	B	10	1.6

方肩刀具 Kr:90°



PE12

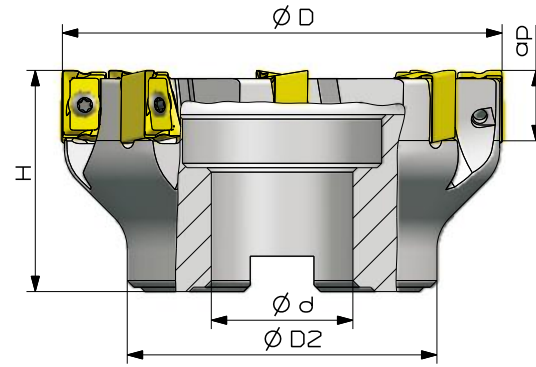

★ 刀具附件 Spare parts

刀片 Insert 	刀片螺钉 Insert Screw 	扳手 Wrench
LN□X151008PNR	TL60 M4X10	T15T

注明：配套刀片建议参考克洛伊品牌刀片。 Note: The insert is Korloy brand.

★ 刀具规格型号 Type of Milling Tools

Type 型号	基本尺寸(mm) Dimension					Adapter 接口 形式	Tooth 齿数	Weight 重量 (kg)
	ØD	Ød	ØD ₂	H	ap			
PE12.15A22.050.04	50	22	40	40	14	A	4	0.4
PE12.15A22.063.06	63	22	50	40	14	A	6	0.6
PE12.15A27.080.07	80	27	60	50	14	A	7	1.2
PE12.15B32.100.8	100	32	70	50	14	B	8	2.4
PE12.15B40.125.10	125	40	80	63	14	B	10	3.8
PE12.15B40.160.12	160	40	100	63	14	B	12	4.6

方肩刀具 Kr:90°



PE14

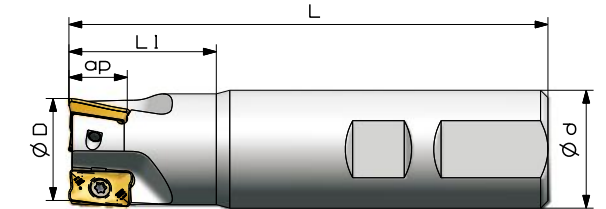

★ 刀具附件 Spare parts

刀片 Insert 	刀片螺钉 Insert Screw 	扳手 Wrench
AXMT11T308	TL60M2.5X6.5	T08

注明：配套刀片与株洲钻石、山特通用。 Note: Replaceable with Zccct/Sandvik brand inserts.

★ 刀具规格型号 Type of Milling Tools

Type 型号	基本尺寸(mm) Dimension					Adapter 接口 形式	Tooth 齿数	Weight 重量 (kg)
	ØD	Ød	L	L ₁	ap			
PE14.11Z16.016.02	16	16	100	20	10	Z	2	0.3
PE14.11Z20.020.02	20	20	110	25	10	Z	2	0.4
PE14.11Z25.025.03	25	25	120	32	10	Z	3	0.5
PE14.11Z32.032.03	32	32	130	40	10	Z	3	0.8
PE14.11Z32.040.04	40	32	170	40	10	Z	4	1.7
PE14.11W16.016.02	16	16	73	25	10	W	2	0.3
PE14.11W20.020.02	20	20	81	25	10	W	2	0.4
PE14.11W25.025.03	25	25	88	32	10	W	3	0.5
PE14.11W32.032.03	32	32	100	40	10	W	3	0.8
PE14.11W32.040.04	40	32	110	40	10	W	4	1.7

可转位铣削刀具 Indexable milling tools

方肩刀具 Kr:90°



PE14

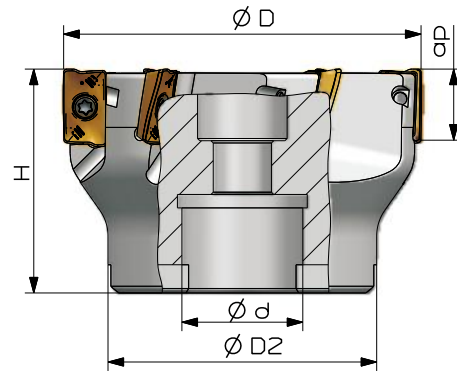

★ 刀具附件 Spare parts

刀片 Insert	刀片螺钉 Insert Screw	扳手 Wrench
AXMT11T308	TL60M2.5X6.5	T08

注明：配套刀片与株洲钻石、山特通用。Note: Replaceable with Zccct/Sandvik brand inserts.

★ 刀具规格型号 Type of Milling Tools

Type 型号	基本尺寸(mm) Dimension					Adapter 接口 形式	Tooth 齿数	Weight 重量 (kg)
	ØD ₂	ØD	Ød	H	a _p			
PE14.11A22.050.06	40	50	22	40	10	A	6	0.5
PE14..11A22.063.08	50	63	22	40	10	A	8	0.6
PE14..11A27.080.09	60	80	27	50	10	A	9	0.9
PE14..11B32.100.10	70	100	32	50	10	B	10	1.0

Indexable milling tools 可转位铣削刀具

★ 刀片选择 Matching Insert

型号 Type	SP210M	SD2136	SD2336	SD4326	SD4226	SD4236	SD5346	SD5236	SD5450	SD5440	SD5146	基本尺寸(mm) Dimension				
												L	ØI.C	S	Ød	r
AXMT11T308-GM	●											11.7	6.93	3.6	2.8	0.8
AXMT170408-PM		●	●		○				○			17.6	9.6	4.76	4.3	0.8
P 钢	□	■	■						■							
M 不锈钢	□	□	■						■							
K 铸铁	■	■	■	■												
N 有色金属																
S 耐热合金、钛合金			■													
H 淬硬材料																

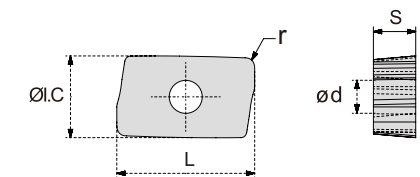

● 常备库存 Unallocated stock ○ 可备库存 Available stock ■ 推荐应用 Main application □ 拓展应用 Extended application

仿形铣刀

RB01

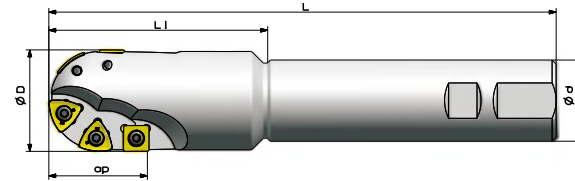
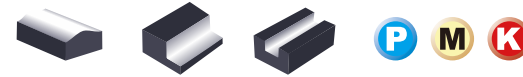

★ 刀具附件 Spare parts

刀片 Insert	刀片 Insert	刀片螺钉 Insert Screw	扳手 Wrench
ZDET08T2CYR10	SPMT060304	TL60 M2.5X5	T08
ZDET1103CYR12.5	SPMT060304	TL60 M2.5X5	T08
ZDET13T3CYR16	SDMT090308	Ti60 M3.5X10	T15
ZPNT2204CYR20	SPMT120408	TL60 M5X13	T20

注明：配套刀片建议参考株洲钻石品牌刀片。Note:The insert is Zccct brand.

★ 刀具规格型号 Type of Milling Tools

Type 型号	基本尺寸(mm) Dimension					Adapter 接口形式	Tooth 齿数	Weight 重量(kg)
	ØD	Ød	L	L1	ap			
RB01.20W20.020.S	20	20	125	50	20	W	4	0.3
RB01.20W20.020.M	20	20	150	75	20	W	4	0.3
RB01.20W20.020.L	20	20	200	100	20	W	4	0.4
RB01.25W25.025.S	25	25	150	70	23	W	4	0.5
RB01.25W25.025.M	25	25	175	95	23	W	4	0.6
RB01.25W25.025.L	25	25	200	100	23	W	4	0.7
RB01.32W32.032.S	32	32	175	85	31	W	4	0.9
RB01.32W32.032.M	32	32	200	100	31	W	4	1.1
RB01.32W32.032.L	32	32	250	150	31	W	4	1.4
RB01.40W32.040.S	40	32	175	50	41	W	5	1.4
RB01.40W32.040.M	40	32	200	50	41	W	5	1.7
RB01.40W32.040.L	40	32	250	50	41	W	5	2.1

了解具体库存情况请致电厂家 详情请登陆网站www.hnsant.com

仿形铣刀

RB02

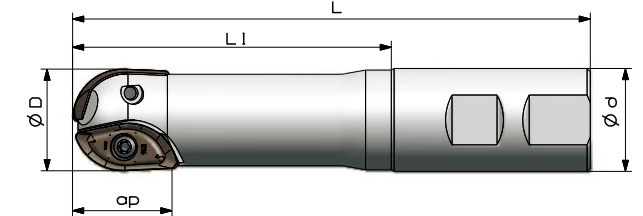
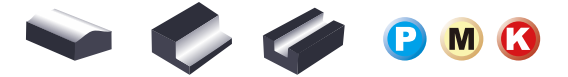

★ 刀具附件 Spare parts

刀片 Insert	压板 Clamp	刀片螺钉 Insert Screw	扳手 Wrench
XPHT16R803		TL60 M2.5X6	T08
XPHT20R10T3		TL60M3.5X8	T15
XPHT25R1204		TL60 M4X10	T15
XPHT30R1506	WD208	TL60 M5X12	T20
XPHT32R1606	WD208	TL60 M5X12	T20

注明：配套刀片建议参考株洲钻石品牌刀片。Note:The insert is Zccct brand.

★ 刀具规格型号 Type of Milling Tools

Type 型号	基本尺寸(mm) Dimension					Adapter 接口形式	Tooth 齿数	Weight 重量(kg)
	ØD	Ød	L	L1	ap			
RB02.16W20.016.S	16	20	111	60	16	W	2	0.2
RB02.20W25.020.S	20	25	127	70	20	W	2	0.3
RB02.20W25.020.M	20	25	150	80	20	W	2	0.4
RB02.25W25.025.S	25	25	137	80	25	W	2	0.4
RB02.25W25.025.M	25	25	200	100	25	W	2	0.6
RB02.30W32.030.S	30	32	161	100	30	W	2	0.8
RB02.30W32.030.M	30	32	250	150	30	W	2	1.3
RB02.32W32.032.S	32	32	161	100	32	W	2	0.8
RB02.32W32.032.M	32	32	250	120	32	W	2	1.3

了解具体库存情况请致电厂家 详情请登陆网站www.hnsant.com

仿形铣刀

RB02

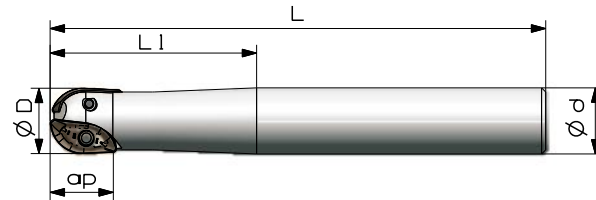
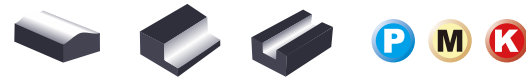

★ 刀具附件 Spare parts

刀片 Insert	压板 Clamp	刀片螺钉 Insert Screw	扳手 Wrench
XPHT16R803		TL60 M2.5X6.5	T08
XPHT20R10T3		TL60M3.5X8	T15
XPHT25R1204		TL60 M4X10	T15
XPHT30R1506	WD208	TL60 M5X12	T20
XPHT32R1606	WD208	TL60 M5X12	T20

注明：配套刀片建议参考株洲钻石品牌刀片。Note:The insert is Zccct brand.

★ 刀具规格型号 Type of Milling Tools

Type 型号	基本尺寸(mm) Dimension					Adapter 接口 形式	Tooth 齿数	Weight 重量(kg)
	ØD	Ød	L	L1	ap			
RB02.16Z20.016.S	16	20	150	70	16	Z	2	0.3
RB02.16Z20.016.M	16	20	180	80	16	Z	2	0.4
RB02.20Z25.020.S	20	25	180	80	20	Z	2	0.5
RB02.20Z25.020.M	20	25	200	100	20	Z	2	0.6
RB02.20Z25.020.L	20	25	250	150	20	Z	2	0.7
RB02.25Z25.025.S	25	25	180	80	25	Z	2	0.6
RB02.25Z25.025.M	25	25	200	100	25	Z	2	0.7
RB02.25Z25.025.L	25	25	250	110	25	Z	2	0.8
RB02.30Z32.030.S	30	32	200	120	30	Z	2	1.0
RB02.30Z32.030.M	30	32	250	150	30	Z	2	1.3
RB02.30Z32.030.L	30	32	300	200	30	Z	2	1.6
RB02.32Z32.032.S	32	32	200	120	32	Z	2	1.1
RB02.32Z32.032.M	32	32	250	150	32	Z	2	1.4
RB02.32Z32.032.L	32	32	300	200	32	Z	2	1.6

仿形铣刀

RB02

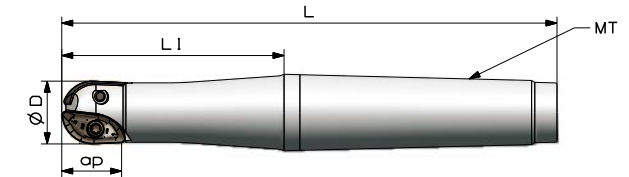
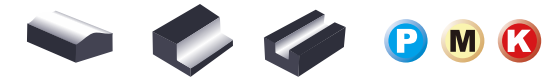

★ 刀具附件 Spare parts

刀片 Insert	压板 Clamp	刀片螺钉 Insert Screw	扳手 Wrench
XPHT16R803		TL60 M2.5X6.5	T08
XPHT20R10T3		TL60M3.5X8	T15
XPHT25R1204		TL60 M4X10	T15
XPHT30R1506	WD208	TL60 M5X12	T20
XPHT32R1606	WD208	TL60 M5X12	T20

注明：配套刀片建议参考株洲钻石品牌刀片。 Note:The insert is Zccct brand.

★ 刀具规格型号 Type of Milling Tools

Type 型号	基本尺寸(mm) Dimension					Tooth 齿数	Weight 重量(kg)
	ØD	MT	L	L1	ap		
RB02.20MT3.020.M	20	3	156	70	20	2	0.4
RB02.20MT3.020.L	20	3	186	100	20	2	0.4
RB02.25MT3.025.M	25	3	156	70	25	2	0.4
RB02.25MT3.025.L	25	3	186	100	25	2	0.4
RB02.30MT4.030.M	30	4	189	70	30	2	0.8
RB02.30MT4.030.L	30	4	229	120	30	2	1.0
RB02.32MT4.032.M	32	4	179	70	32	2	0.9
RB02.32MT4.032.L	32	4	209	100	32	2	0.9

仿形铣刀

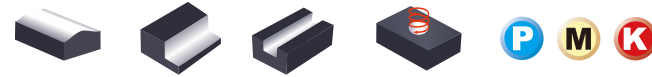

RB03

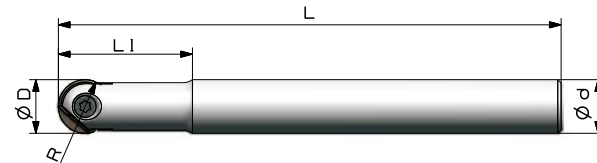

★ 刀具附件 Spare parts

Diameter 直径	刀片 Insert	刀片螺钉 Insert Screw	扳手 Wrench
φ 12	ZOHX1203	I70 M4X10TT	T15
φ 16	ZOHX1604	I70 M5X12TT	T20
φ 20	ZOHX2005	I70 M5X16TT	T20
φ 25	ZOHX2506	I70 M6X20TT	T20
φ 30	ZOHX3007	I70 M8X25TT	T30S
φ 32	ZOHX3207	I70 M8X25TT	T30S

注明：配套刀片建议参考株洲钻石品牌刀片。Note:The insert is Zccct brand.

★ 刀具规格型号 Type of Milling Tools

Category 类别	Type 型号	基本尺寸(mm) Dimension					Adapter 接口 形式	Tooth 齿数	Weight 重量(kg)
		ØD	Ød	L	L1	R			
φ 12	RB03.12Z12.012.M	12	12	125	35	6	Z	1	0.1
	RB03.12Z12.012.L	12	12	150	45	6	Z	1	0.1
	RB03.12Z16.012.M	12	16	125	50	6	Z	1	0.2
	RB03.12Z16.012.L	12	16	150	70	6	Z	1	0.2
φ 16	RB03.16Z16.016.M	16	16	150	40	8	Z	1	0.2
	RB03.16Z16.016.L	16	16	180	55	8	Z	1	0.3
	RB03.16Z20.016.M	16	20	150	60	8	Z	1	0.3
	RB03.16Z20.016.L	16	20	180	80	8	Z	1	0.3
φ 20	RB03.20Z20.020.M	20	20	180	65	10	Z	1	0.4
	RB03.20Z20.020.L	20	20	250	100	10	Z	1	0.6
	RB03.20Z25.020.M	20	25	180	75	10	Z	1	0.6
	RB03.20Z25.020.L	20	25	200	95	10	Z	1	0.8

仿形铣刀

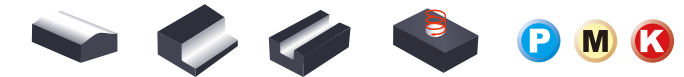

★ 刀具规格型号 Type of Milling Tools

Category 类别	Type 型号	基本尺寸(mm) Dimension					Adapter 接口 形式	Tooth 齿数	Weight 重量(kg)
		ØD	Ød	L	L1	R			
φ 25	RB03.25Z25.025.M	25	25	200	70	12.5	Z	1	0.7
	RB03.25Z25.025.L	25	25	250	100	12.5	Z	1	0.9
	RB03.25Z32.025.M	25	32	200	90	12.5	Z	1	1.0
	RB03.25Z32.025.L	25	32	250	110	12.5	Z	1	1.3
φ 30	RB03.30Z32.030.M	30	32	250	80	15	Z	1	1.2
	RB03.30Z32.030.L	30	32	300	110	15	Z	1	1.5
φ 32	RB03.32Z32.032.M	32	32	250	80	16	Z	1	1.4
	RB03.32Z32.032.L	32	32	300	110	16	Z	1	1.7

仿形铣刀

RB04

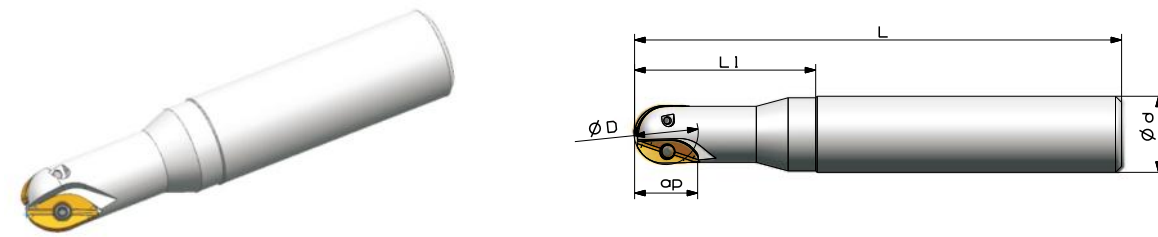
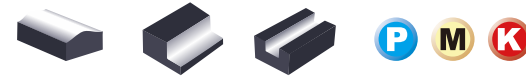

★ 刀具附件 Spare parts

刀片 Insert	刀片 Insert	刀片螺钉 Insert Screw	扳手 Wrench
ZNMT1804100-C	ZNMT2004100-S	TL60 M3X7	T10
ZNMT2205125-C	ZNMT2305125-S	TL60 M4X10	T15
ZNMT2706150-C	ZNMT2806150-S	TL60 M4X10/TL60M5X12	T15/T20

注明：配套刀片建议参考住友品牌刀片。Note:The insert is Sumitomo brand.

★ 刀具规格型号 Type of Milling Tools

Type 型号	基本尺寸(mm) Dimension					Adapter 接口 形式	Tooth 齿数	Weight 重量(kg)
	ØD	Ød	L	L1	ap			
RB04.20Z25.020.S	20	25	140	60	20	Z	2	0.3
RB04.20Z25.020.M	20	25	200	60	20	Z	2	0.5
RB04.20Z25.020.L	20	25	250	80	20	Z	2	0.7
RB04.25Z32.025.S	25	32	150	70	23	Z	2	0.6
RB04.25Z32.025.M	25	32	220	75	23	Z	2	0.8
RB04.25Z32.025.L	25	32	300	100	23	Z	2	1.0
RB04.30Z32.030.S	30	32	160	80	28	Z	2	0.9
RB04.30Z32.030.M	30	32	240	85	28	Z	2	1.2
RB04.30Z32.030.L	30	32	350	120	28	Z	2	1.8

三面刃铣削刀具

PT01

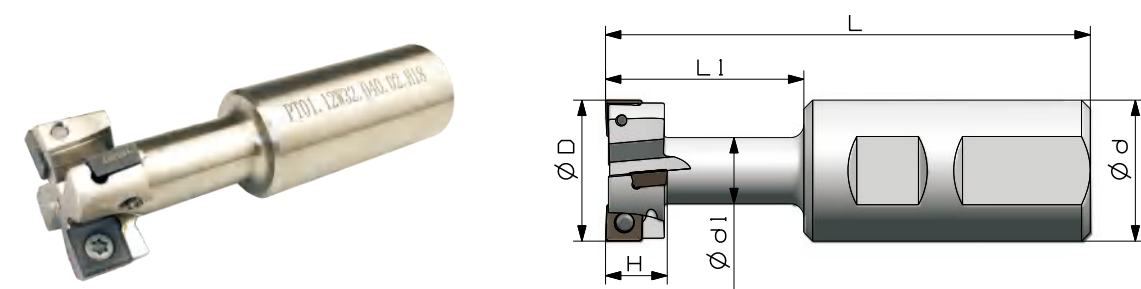

★ 刀具附件 Spare parts

刀片 Insert	刀片螺钉 Insert Screw	扳手 Wrench
MPHT060304-DM	TL60M2.5X6.5	T08
MPHT080305-DM	TL60M3X7	T10
MPHT120408-DM	TL60M5X11	T20

注明：配套刀片与株洲钻石通用。Note:Replaceable with Zccct brand inserts.

★ 刀具规格型号 Type of Milling Tools

Type 型号	基本尺寸(mm) Dimension						Tooth 齿数	Weight 重量(kg)
	ØD	Ød	Ød1	L	L1	H		
PT01.06W25.021.01.H9	21	25	10	100	32	9	1	0.2
PT01.06W25.025.01.H11	25	25	12	100	35	11	1	0.3
PT01.08W32.032.02.H14	32	32	15	110	45	14	2	0.5
PT01.12W32.040.02.H18	40	32	19	125	55	18	2	0.7
PT01.12W40.050.02.H22	50	40	25	140	65	22	2	1.2

三面刀刃铣削刀具



PT01

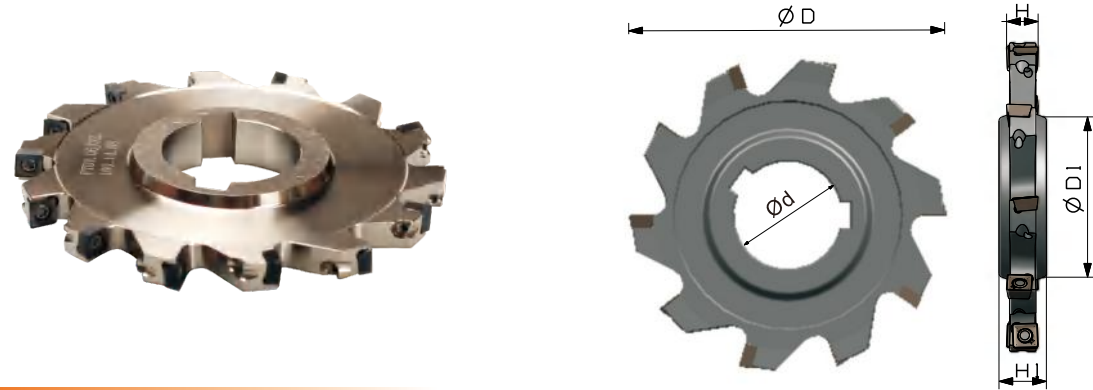

★ 刀具附件 Spare parts

刀片 Insert	刀片螺钉 Insert Screw	扳手 Wrench
MPHT060304-DM	TL60 M2.5X6.5	T08T
MPHT080305-DM	TL60M3X7	T10T
MPHT120408-DM	TL60 M5X11	T20T

注明：配套刀片与株洲钻石通用。Note: Replaceable with Zccct brand inserts.

★ 刀具规格型号 Type of Milling Tools

Category 类别	Type 型号	基本尺寸(mm) Dimension					Tooth 齿数	Weight 重量(kg)
		ØD	ØD1	Ød	H1	H		
MP06	PT01.06J27.080.10.H8	80	41	27	12	8	10	0.2
	PT01.06J32.100.14.H8	100	47	32	12	8	14	0.3
	PT01.06J32.100.14.H10	100	47	32	14	10	14	0.4
	PT01.06J40.125.16.H10	125	55	40	14	10	16	0.6
	PT01.08J40.125.12.H12	125	55	40	16	12	12	0.7
MP08	PT01.08J40.160.14.H12	160	62	40	16	12	14	1.3
	PT01.12J40.160.12.H16	160	62	40	20	16	12	1.6
	PT01.12J40.160.12.H18	160	62	40	24	18	12	1.9
MP12	PT01.12J40.160.12.H20	160	62	40	26	20	12	2.1
	PT01.12J50.200.14.H16	200	72	50	20	16	14	2.5
	PT01.12J50.200.14.H18	200	72	50	24	18	14	2.9
	PT01.12J50.200.14.H20	200	72	50	26	20	14	3.3

了解具体库存情况请致电厂家 详情请登陆网站www.hnsant.com

三面刀刃铣削刀具



PT01

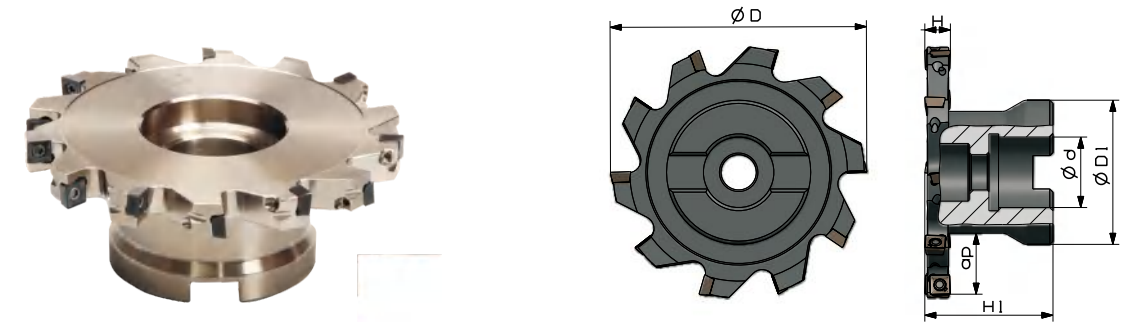

★ 刀具附件 Spare parts

刀片 Insert	刀片螺钉 Insert Screw	扳手 Wrench
MPHT060304-DM	TL60 M2.5X6.5	T08T
MPHT080305-DM	TL60M3X7	T10T
MPHT120408-DM	TL60 M5X10	T20T

注明：配套刀片与株洲钻石通用。Note: Replaceable with Zccct brand inserts.

★ 刀具规格型号 Type of Milling Tools

Category 类别	Type 型号	基本尺寸(mm) Dimension						Tooth 齿数	Adapter 接口 形式	Weight 重量 (kg)
		ØD	ØD1	Ød	H1	H	ap			
MP06	PT01.06A22.080.10.H8	80	45	22	40	8	21	10	A	0.4
	PT01.06B27.100.14.H8	100	55	27	40	8	24	14	B	0.6
	PT01.06B27.100.14.H10	100	55	27	40	10	24	14	B	0.7
	PT01.06B32.125.16.H10	125	65	32	45	10	33	16	B	1.1
	PT01.08B32.125.12.H12	125	65	32	45	12	33	12	B	1.4
MP08	PT01.08B40.160.14.H12	160	80	40	45	12	45	14	B	1.9
	PT01.08C40.200.18.H12	200	92	40	50	12	53	18	C	3.2
	PT01.12B32.125.10.H16	125	65	32	50	16	30	10	B	2.3
MP12	PT01.12B40.160.12.H16	160	80	40	60	16	45	12	B	2.3
	PT01.12B40.160.12.H18	160	80	40	60	18	45	12	B	2.4
	PT01.12C40.200.14.H16	200	92	40	50	16	53	14	C	2.6
	PT01.12C40.200.14.H18	200	92	40	50	18	53	14	C	3.9
	PT01.12C40.200.14.H20	200	92	40	50	20	53	14	C	4.2

了解具体库存情况请致电厂家 详情请登陆网站www.hnsant.com

铣削刀具 | MILLING TOOLS



可转位铣削刀具 Indexable milling tools

★ 刀片选择 Matching Insert

型号 Type	SK001	SD2136	SD2336	SD4326	SD4226	SD4236	SD5346	SD5236	SD5450	SD5440	SD5146	基本尺寸(mm) Dimension				
												L	ØI.C	S	Ød	r
MPHT060304-DM	○	●	●	○					○			6.35	6.35	3.18	2.8	0.4
MPHT080305-DM	○	●	●	○					○			8.3	8.3	3.18	3.4	0.5
MPHT120408-DM	○	●	●	○					○			12.7	12.7	4.76	5.56	0.8
P 钢		■	■						■							
M 不锈钢		□	■						■							
K 铸铁			■	■												
N 有色金属		■														
S 耐热合金、钛合金			■													
H 淬硬材料																

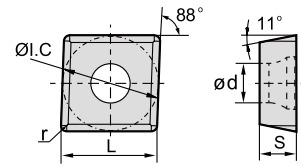

● 常备库存 Unallocated stock ○ 可备库存 Available stock ■ 推荐应用 Main application □ 拓展应用 Extended application



铣削刀具 | MILLING TOOLS

Indexable milling tools 可转位铣削刀具

三面刃铣削刀具



PT02

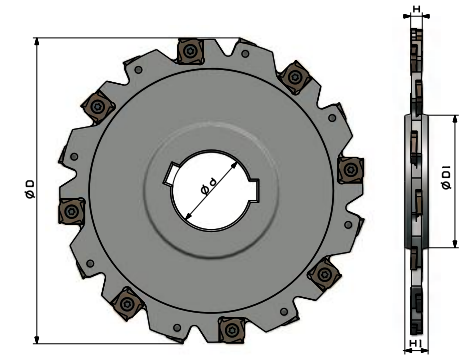

★ 刀具附件 Spare parts

刀片 Insert	刀片螺钉 Insert Screw	扳手 Wrench
XSEQ1202	I91M4X3.2X	T09T
XSEQ1203	I91M4X4.2X	T15T
XSEQ12T3	I91M4X5.1X	T15T
XSEQ1204	I91M4X6.3X	T15T
XSEQ12T4	I91M4X6.3X	T15T

注明：配套刀片与株洲钻石通用。Note: Replaceable with Zccct brand inserts.

★ 刀具规格型号 Type of Milling Tools

Category 类别	Type 型号	基本尺寸(mm) Dimension					Tooth 齿数	Weight 重量(kg)
		ØD	ØD1	Ød	H1	H		
02	PT02.12J27.100.10.H4	100	40.7	27	12	4	10	0.2
	PT02.12J40.125.12.H4	125	50.5	40	12	4	12	0.3
	PT02.12J40.160.16.H4	160	66.7	40	12	4	16	0.5
03	PT02.12J27.100.10.H5	100	45	27	12	5	10	0.2
	PT02.12J40.125.12.H5	125	58	40	12	5	12	0.3
	PT02.12J40.160.16.H5	160	68	40	12	5	16	0.6
T3	PT02.12J27.100.10.H6	100	45	27	12	6	10	0.3
	PT02.12J40.125.12.H6	125	58	40	12	6	12	0.4
	PT02.12J40.160.16.H6	160	68	40	12	6	16	0.7
	PT02.12J50.200.18.H6	200	72	50	12	6	18	1.1
	PT02.12J50.250.24.H6	250	72	50	12	6	24	1.7

三面刀刃铣削刀具



★ 刀具规格型号 Type of Milling Tools

Category 类别	Type 型号	基本尺寸(mm) Dimension					Tooth 齿数	Weight 重量 (kg)
		ØD	ØD1	Ød	H1	H		
04	PT02.12J27.100.10.H7	100	45	27	12	7	10	0.3
	PT02.12J40.125.12.H7	125	58	40	12	7	12	0.4
	PT02.12J40.160.16.H7	160	68	40	12	7	16	0.8
	PT02.12J50.200.18.H7	200	72	50	12	7	18	1.2
	PT02.12J50.250.24.H7	250	72	50	12	7	24	1.9
T4	PT02.12J27.100.10.H8	100	45	27	12	8	10	0.3
	PT02.12J40.125.12.H8	125	58	40	12	8	12	0.5
	PT02.12J40.160.16.H8	160	68	40	12	8	16	0.9
	PT02.12J50.200.18.H8	200	72	50	12	8	18	1.4
	PT02.12J50.250.24.H8	250	72	50	12	8	24	2.2

三面刀刃铣削刀具



PT02

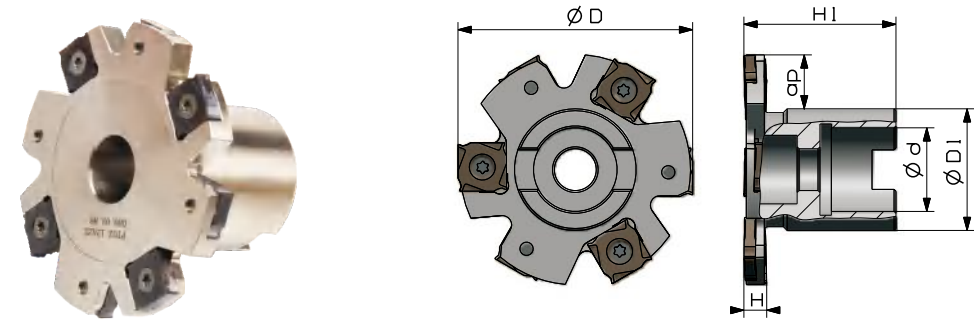

★ 刀具附件 Spare parts

刀片 Insert	刀片螺钉 Insert Screw	扳手 Wrench
XSEQ1202	I91M4X3.2X	T09T
XSEQ1203	I91M4X4.2X	T15T
XSEQ12T3	I91M4X5.1X	T15T
XSEQ1204	I91M4X6.3X	T15T
XSEQ12T4	I91M4X6.3X	T15T

注明：配套刀片与株洲钻石通用。Note: Replaceable with Zccct brand inserts.

★ 刀具规格型号 Type of Milling Tools

Category 类别	Type 型号	基本尺寸(mm) Dimension						Adapter 接口 形式	Tooth 齿数	Weight 重量 (kg)
		ØD	ØD1	Ød	H1	H	ap			
02	PT02.12A22.063.06.H4	63	32	22	40	4	14	A	6	0.2
	PT02.12A22.080.08.H4	80	40	22	50	4	18	A	8	0.4
	PT02.12A27.100.10.H4	100	48	27	50	4	23	A	10	0.6
03	PT02.12A22.063.06.H5	63	32	22	40	5	14	A	6	0.2
	PT02.12A22.080.08.H5	80	40	22	50	5	18	A	8	0.4
	PT02.12A27.100.10.H5	100	48	27	50	5	23	A	10	0.7
T3	PT02.12A22.063.06.H6	63	32	22	40	6	14	A	6	0.2
	PT02.12A22.080.08.H6	80	40	22	50	6	18	A	8	0.4
	PT02.12A27.100.10.H6	100	48	27	50	6	23	A	10	0.7
	PT02.12B40.125.12.H6	125	70	40	50	6	30	B	12	1.0
	PT02.12B40.160.16.H6	160	70	40	50	6	41	B	16	1.3

三面刀刃铣削刀具



★ 刀具规格型号 Type of Milling Tools

Category 类别	Type 型号	基本尺寸(mm) Dimension						Adapter 接口 形式	Tooth 齿数	Weight 重量 (kg)
		ØD	ØD1	Ød	H1	H	ap			
04	PT02.12A22.063.06.H7	63	32	22	40	7	14	A	6	0.2
	PT02.12A22.080.08.H7	80	40	22	50	7	18	A	8	0.5
	PT02.12A27.100.10.H7	100	48	27	50	7	23	A	10	0.7
	PT02.12B40.125.12.H7	125	70	40	50	7	27	B	12	1.1
	PT02.12B40.160.16.H7	160	70	40	50	7	41	B	16	1.4
T4	PT02.12A22.063.06.H8	63	32	22	40	8	14	A	6	0.2
	PT02.12A22.080.08.H8	80	40	22	50	8	18	A	8	0.5
	PT02.12A27.100.10.H8	100	48	27	50	8	23	A	10	0.8
	PT02.12B40.125.12.H8	125	70	40	50	8	27	B	12	1.1
	PT02.12B40.160.16.H8	160	70	40	50	8	41	B	16	1.5

★ 刀片选择 Matching Insert

型号 Type	SD2136	SD2336	SD4326	SD4226	SD4236	SD5346	SD5236	SD5450	SD5440	SD5146	基本尺寸(mm) Dimension			
											ØI.C	S	Ød	L
XSEQ1202	○	○									12.7	2.3	5	12.7
XSEQ1203	○	○									12.7	3	5	12.7
XSEQ12T3	○	○									12.7	3.5	5	12.7
XSEQ1204	○	○									12.7	4	5	12.7

- P** 钢
- M** 不锈钢
- K** 铸铁
- N** 有色金属
- S** 耐热合金、钛合金
- H** 淬硬材料

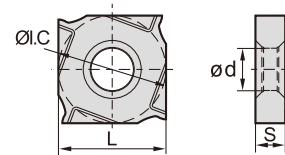

● 常备库存 Unallocated stock ○ 可备库存 Available stock ■ 推荐应用 Main application □ 拓展应用 Extended application

三面刀刃铣削刀具



PT03

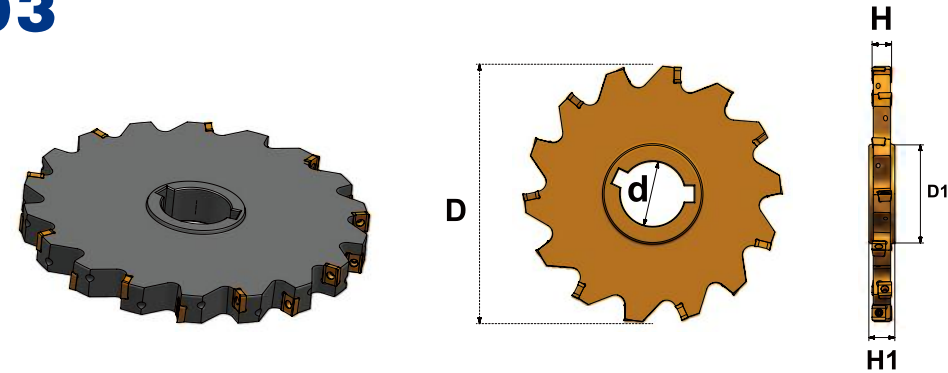

★ 刀具附件 Spare parts

刀片 Insert	刀片螺钉 Insert Screw	扳手 Wrench
X3-084508H	TL60M3X8	T10
X3-115008H	TL60M4X10	T15
X3-145008H	TL60M4X10	T15

注明：配套刀片与山特通用。Note: Replaceable with Sandvik brand inserts.

★ 刀具规格型号 Type of Milling Tools

Category 类别	Type 型号	基本尺寸(mm) Dimension					Tooth 齿数	Weight 重量(kg)
		ØD	ØD1	Ød	H	H1		
08	PT03.08J40.125.12.H12	125	55	40	12	16	12	0.72
	PT03.08J40.160.14.H12	160	62	40	12	16	14	1.32
11	PT03.11J40.160.14.H16	160	62	40	16	20	14	1.80
	PT03.11J40.160.14.H18	160	62	40	18	24	14	2.10
	PT03.11J50.200.16.H16	200	72	50	16	20	16	2.90
14	PT03.11J50.200.16.H18	200	72	50	18	24	16	3.35
	PT03.14J50.200.16.H20	200	72	50	20	26	16	3.67
	PT03.14J50.200.16.H24	200	72	50	24	28	16	4.41
	PT03.14J50.250.18.H20	250	72	50	20	26	18	6.12
	PT03.14J50.250.18.H24	250	72	50	24	28	18	7.38

三面刃铣削刀具

PT03

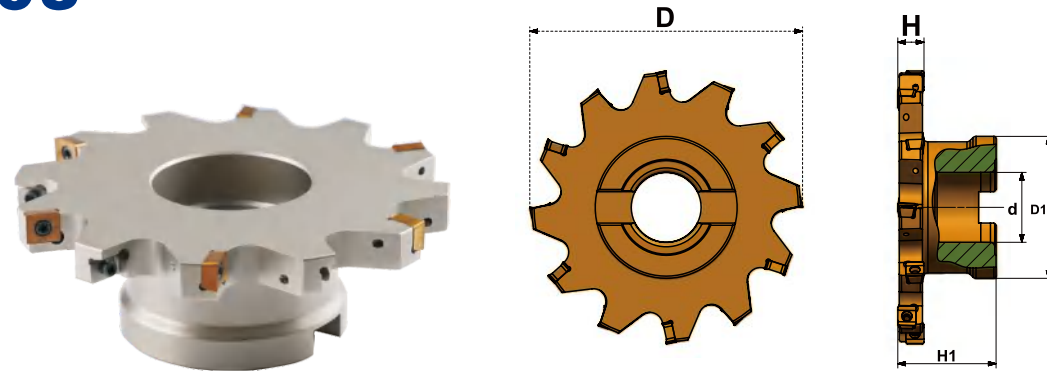

★ 刀具附件 Spare parts

刀片 Insert	刀片螺钉 Insert Screw	扳手 Wrench
X3-084508H	TL60M3X8	T10
X3-115008H	TL60M4X10	T15
X3-145008H	TL60M4X10	T15

注明：配套刀片与山特通用。Note: Replaceable with Sandvik brand inserts.

★ 刀具规格型号 Type of Milling Tools

Category 类别	Type 型号	基本尺寸(mm) Dimension					Tooth 齿数	Adapter 接口 形式	Weight 重量(kg)
		ØD	ØD1	Ød	H	H1			
08	PT03.08B32.125.12.H12	125	65	32	12	45	12	B	1.2
	PT03.08B40.160.14.H12	160	80	40	12	45	12	B	2.2
11	PT03.11B40.160.14.H16	160	80	40	16	50	14	B	2.5
	PT03.11B40.160.14.H18	160	80	40	18	50	14	B	2.7
	PT03.11C40.200.16.H16	200	92	40	16	50	16	C	4.0
	PT03.11C40.200.16.H18	200	92	40	18	50	16	C	4.3
14	PT03.14C40.200.16.H20	200	92	40	20	50	16	C	4.5
	PT03.14C40.200.16.H24	200	92	40	24	50	16	C	4.7
	PT03.14C60.250.18.H20	250	135	60	20	63	18	C	8.6
	PT03.14C60.250.18.H24	250	135	60	24	63	18	C	8.9

★ 刀片选择 Matching Insert

型号 Type	SP210M	SP210T	SD2136	SD2336	SD4326	SD4226	SD4236	SD5346	SD5236	SD5450	基本尺寸(mm) Dimension			
											la	l	iW	S
X3-084508H	○	○									7.7	8.5	9.5	4.95
X3-115008H	○	○									10.7	11.5	11.5	4.95
X3-145008H	○	○									13.7	14.5	11.5	4.95

P 钢	<input type="checkbox"/>	<input checked="" type="checkbox"/>												
M 不锈钢	<input type="checkbox"/>	<input type="checkbox"/>												
K 铸铁		<input checked="" type="checkbox"/>	<input type="checkbox"/>											
N 有色金属														
S 耐热合金、钛合金														
H 淬硬材料														

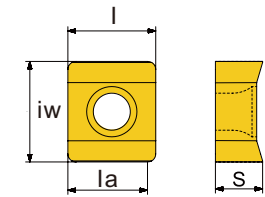

● 常备库存 Unallocated stock ○ 可备库存 Available stock ■ 推荐应用 Main application □ 拓展应用 Extended application

三面刃铣削刀具



PT04

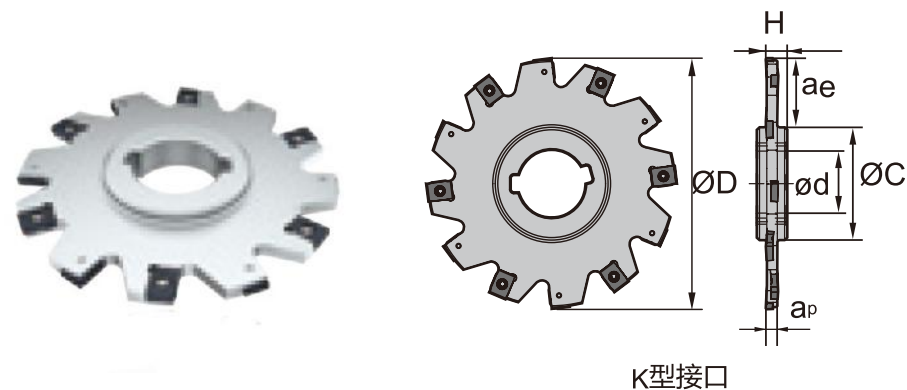

★ 刀具附件 Spare parts

刀具直径 Diameter ØD	刃宽 ap Cutting Edge (mm)	刀片螺钉 Insert Screw	扳手 Wrench
Ø63-Ø160	4	TL60M2.5X3.2	T06
	5	TL60M2.5X3.9	
Ø63-Ø250	6	TL60M2.5X4.8	T10
	7	TL60M4X5.1	
	8	TL60M4X6.6	
	9	TL60M4X7.6	
	10	TL60M4X8.5	

注明：配套刀片与株洲钻石通用。Note: Replaceable with Zccct brand inserts.

★ 刀具规格型号 Type of Milling Tools

Category 类别	型号	基本尺寸(mm) Dimension						Tooth 齿数	Adapter 接口 形式	Weight 重量(kg)
		ØD	Ød	Øc	H	ap	aemax			
1023	PT04.LN1023.J22.063.08.H4	63	22	34	8	4	12.0	8	K	0.1
	PT04.LN1023.J22.080.10.H4	80	22	34	8	4	21.0	10	K	0.1
	PT04.LN1023.J27.100.12.H4	100	27	41	12	4	27.0	12	K	0.2
	PT04.LN1023.J40.125.14.H4	125	40	55	12	4	32.0	14	K	0.4
	PT04.LN1023.J40.160.18.H4	160	40	55	12	4	50.0	18	K	0.6
1028	PT04.LN1028.J22.063.08.H5	63	22	34	8	5	13.0	8	K	0.1
	PT04.LN1028.J22.080.10.H5	80	22	34	8	5	21.0	10	K	0.2
	PT04.LN1028.J27.100.12.H5	100	27	41	12	5	27.0	12	K	0.3
	PT04.LN1028.J27.100.12.H5	125	40	55	12	5	33.0	14	K	0.4
	PT04.LN1028.J40.160.18.H5	160	40	55	12	5	50.0	18	K	0.7

了解具体库存情况请致电厂家 详情请登陆网站www.hnsant.com

三面刃铣削刀具



★ 刀具规格型号 Type of Milling Tools

Category 类别	Type 型号	基本尺寸(mm) Dimension						Tooth 齿数	Adapter 接口 形式	Weight 重量(kg)
		ØD	Ød	Øc	H	ap	aemax			
1033	PT04.LN1033.J22.063.08.H6	63	22	34	8	6	13.0	8	K	0.1
	PT04.LN1033.J22.080.10.H6	80	22	34	8	6	21.5	10	K	0.2
	PT04.LN1033.J27.100.12.H6	100	27	41	12	6	27.0	12	K	0.3
	PT04.LN1033.J40.125.14.H6	125	40	55	12	6	33.0	14	K	0.5
	PT04.LN1033.J40.160.18.H6	160	40	55	12	6	50.0	18	K	0.8
	PT04.LN1033.J50.200.20.H6	200	50	69	12	6	63.0	20	K	1.2
1238	PT04.LN1238.J22.080.08.H7	80	22	34	12	7	20.0	8	K	0.2
	PT04.LN1238.J27.100.10.H7	100	27	41	12	7	26.5	10	K	0.3
	PT04.LN1238.J40.125.12.H7	125	40	55	12	7	32.0	12	K	0.5
	PT04.LN1238.J40.160.16.H7	160	40	55	12	7	49.5	16	K	0.8
	PT04.LN1238.J50.200.18.H7	200	50	69	12	7	62.5	18	K	1.3
1243	PT04.LN1238.J50.250.24.H7	250	50	69	12	7	87.5	24	K	2.1
	PT04.LN1243.J22.080.08.H8	80	22	34	12	8	20.5	8	K	0.2
	PT04.LN1243.J27.100.10.H8	100	27	41	12	8	27.0	10	K	0.3
	PT04.LN1243.J27.100.10.H8	125	40	55	12	8	32.5	12	K	0.9
	PT04.LN1243.J40.160.16.H8	160	40	55	12	8	50.0	16	K	0.9
1248	PT04.LN1243.J50.200.18.H8	200	50	69	12	8	63.0	18	K	1.4
	PT04.LN1243.J50.250.24.H8	250	50	69	12	8	83.0	24	K	2.3
	PT04.LN1248.J27.100.10.H9	100	27	41	12	9	27.5	10	K	0.4
	PT04.LN1248.J40.125.12.H9	125	40	55	12	9	33.0	12	K	0.6
	PT04.LN1248.J40.160.16.H9	160	40	55	12	9	50.5	16	K	1
1253	PT04.LN1248.J50.200.18.H9	200	50	69	12	9	63.5	18	K	1.6
	PT04.LN1248.J50.250.24.H9	250	50	69	12	9	88.5	24	K	2.6
	PT04.LN1253.J27.100.10.H10	100	27	41	12	10	28.0	10	K	0.4
	PT04.LN1253.J40.125.12.H10	125	40	55	12	10	33.5	12	K	0.6
	PT04.LN1253.J40.160.16.H10	160	40	55	12	10	51.0	16	K	1.1
	PT04.LN1253.J50.200.18.H10	200	50	69	12	10	64.0	18	K	1.8
	PT04.LN1253.J50.250.24.H10	250	50	69	12	10	89.0	24	K	2.9

了解具体库存情况请致电厂家 详情请登陆网站www.hnsant.com

三面刀刃铣削刀具



PT04

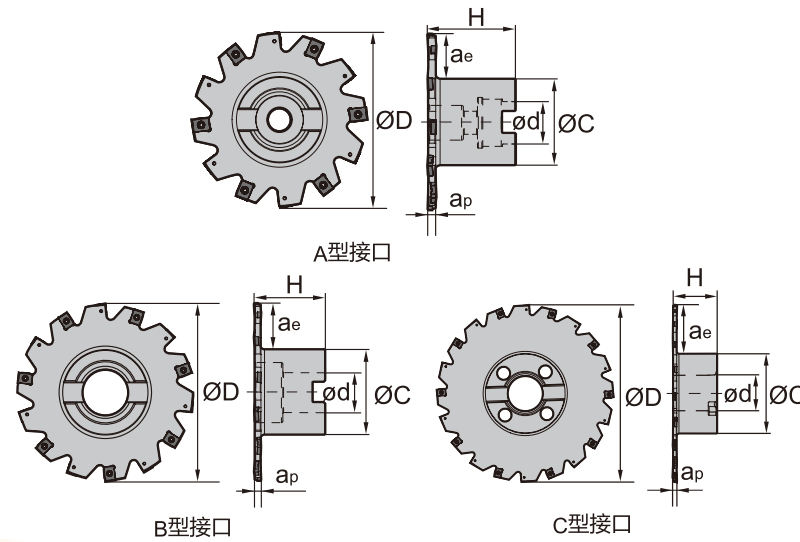

★ 刀具附件 Spare parts

刀具直径 Diameter ØD	刃宽 ap Cutting Edge (mm)	刀片螺钉 Insert Screw 	扳手 Wrench
Ø63-Ø160	4	TL60M2.5X3.2	T06
	5	TL60M2.5X3.9	
Ø63-Ø250	6	TL60M2.5X4.8	T10
	7	TL60M4X5.1	
	8	TL60M4X6.6	
	9	TL60M4X7.6	
	10	TL60M4X8.5	

注明：配套刀片与株洲钻石通用。Note: Replaceable with Zccct brand inserts.

★ 刀具规格型号 Type of Milling Tools

Category 类别	型号	基本尺寸(mm) Dimension						Tooth 齿数	Adapter 接口 形式	Weight 重量(kg)
		ØD	Ød	Øc	H	ap	aemax			
1023	PT04.LN1023.A22.080.10.H4	80	22	42	50	4	18	10	A	0.4
	PT04.LN1023.A27.100.12.H4	100	27	52	50	4	23	12	A	0.6
	PT04.LN1023.B32.125.14.H4	125	32	63	50	4	30	14	B	1.0
	PT04.LN1023.B40.160.18.H4	160	40	76	50	4	41	18	B	1.2
1028	PT04.LN1028.A22.080.10.H5	80	22	42	50	5	18	10	A	0.4
	PT04.LN1028.A27.100.12.H5	100	27	52	50	5	23	12	A	0.6
	PT04.LN1028.B32.125.14.H5	125	32	63	50	5	30	14	B	1.0
	PT04.LN1028.B40.160.18.H5	160	40	76	50	5	41	18	B	1.2

三面刀刃铣削刀具



★ 刀具规格型号 Type of Milling Tools

Category 类别	型号	基本尺寸(mm) Dimension						Tooth 齿数	Adapter 接口 形式	Weight 重量(kg)
		ØD	Ød	Øc	H	ap	aemax			
1033	PT04.LN1033.A22.080.10.H6	80	22	42	50	6	18	10	A	0.5
	PT04.LN1033.A27.100.12.H6	100	27	52	50	6	23	12	A	0.7
	PT04.LN1033.B32.125.14.H6	125	32	63	50	6	30	14	B	1.1
	PT04.LN1033.B40.160.18.H6	160	40	76	50	6	41	18	B	1.4
	PT04.LN1033.C40.200.20.H6	200	40	94	50	6	52	20	C	2.8
	PT04.LN1033.C60.250.24.H6	250	60	132	50	6	58	24	C	4.6
1238	PT04.LN1238.A22.080.08.H7	80	22	42	50	7	18	8	A	0.5
	PT04.LN1238.A27.100.10.H7	100	27	52	50	7	23	10	A	0.7
	PT04.LN1238.B32.125.12.H7	125	32	63	50	7	30	12	B	1.1
	PT04.LN1238.B40.160.16.H7	160	40	76	50	7	41	16	B	1.4
	PT04.LN1238.C40.200.18.H7	200	40	94	50	7	52	18	C	2.9
	PT04.LN1238.C60.250.24.H7	250	60	132	50	7	58	24	C	4.7

三面刀刃铣削刀具



PT04

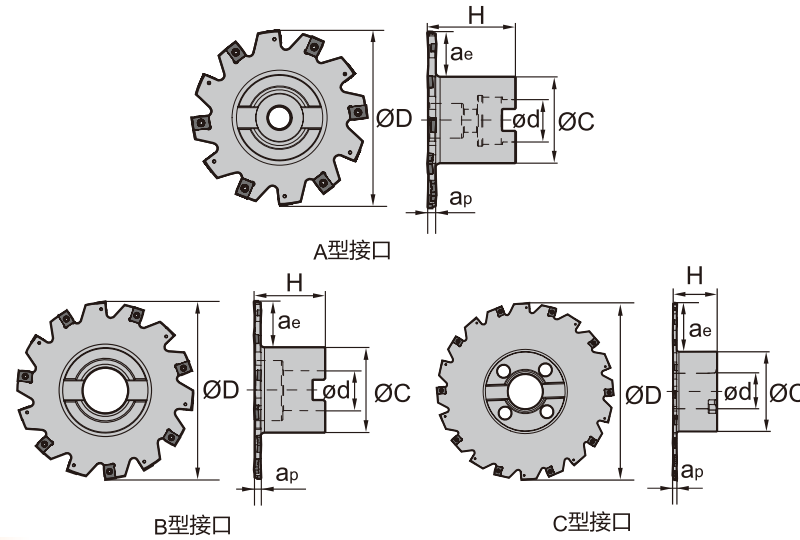

★ 刀具附件 Spare parts

刀具直径 Diameter ØD	刃宽 ap Cutting Edge (mm)	刀片螺钉 Insert Screw	扳手 Wrench
Ø63-Ø160	4	TL60M2.5X3.2	T06
	5	TL60M2.5X3.9	
	6	TL60M2.5X4.8	
Ø63-Ø250	7	TL60M4X5.1	T10
	8	TL60M4X6.6	
	9	TL60M4X7.6	
	10	TL60M4X8.5	

注明：配套刀片与株洲钻石通用。Note: Replaceable with Zccct brand inserts.

★ 刀具规格型号 Type of Milling Tools

Category 类别	型号	基本尺寸(mm) Dimension						Tooth 齿数	Adapter 接口 形式	Weight 重量(kg)
		ØD	Ød	Øc	H	ap	aemax			
1243	PT04.LN1243A22.080.08.H8	80	22	42	50	8	18	8	A	0.5
	PT04.LN1243.A27.100.10.H8	100	27	52	50	8	23	10	A	0.7
	PT04.LN1243.B32.125.12.H8	125	32	63	50	8	30	12	B	1.1
	PT04.LN1243.B40.160.16.H8	160	40	76	50	8	41	16	B	1.4
	PT04.LN1243.C40.200.18.H8	200	40	94	50	8	52	18	A	2.9
	PT04.LN1243.C60.250.24.H8	250	60	132	50	8	58	24	A	4.7

三面刀刃铣削刀具



★ 刀具规格型号 Type of Milling Tools

Category 类别	型号	基本尺寸(mm) Dimension						Tooth 齿数	Adapter 接口 形式	Weight 重量(kg)
		ØD	Ød	Øc	H	ap	aemax			
1248	PT04.LN1248.A27.100.10.H9	100	27	52	50	9	23	10	A	0.7
	PT04.LN1248.B32.125.12.H9	125	32	63	50	9	30	12	B	1.1
	PT04.LN1248.B40.160.16.H9	160	40	76	50	9	41	16	B	1.5
	PT04.LN1248.C40.200.18.H9	200	40	94	50	9	52	18	C	3
	PT04.LN1248.C60.250.24.H9	250	60	132	50	9	58	24	C	4.8
1253	PT04.LN1253.A27.100.10.H10	100	27	52	50	10	23	10	A	0.7
	PT04.LN1253.B32.125.12.H10	125	32	63	50	10	30	12	B	1.1
	PT04.LN1253.B40.160.16.H10	160	40	76	50	10	41	16	B	1.5
	PT04.LN1253.C40.200.18.H10	200	40	94	50	10	52	18	C	3
	PT04.LN1253.C60.250.24.H10	250	60	132	50	10	58	24	C	5

★ 刀片选择 Matching Insert

型号 Type	SP210M	SP210T	SD2136	SD2336	SD4326	SD4226	SD4236	SD5346	SD5236	SD5450	基本尺寸(mm) Dimension				
											Ø.I.W	L	S	Ød	r
LNET102304-GM	○	○									7.5	10	2.3	2.9	0.4
LNET102804-GM	○	○									7.5	10	2.8	2.9	0.4
LNET103304-GM	○	○									7.5	10	3.3	2.9	0.4
LNET123804-GM	○	○									10	13	3.8	4.4	0.4
LNET124304-GM	○	○									10	13	4.3	4.4	0.4
LNET124804-GM	○	○									10	13	4.8	4.4	0.4
LNET125304-GM	○	○									10	13	5.3	4.4	0.4
P 钢	□	■													
M 不锈钢	□	□													
K 铸铁		■	□												
N 有色金属															
S 耐热合金、钛合金															
H 淬硬材料															

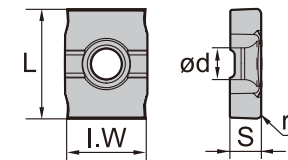

● 常备库存 Unallocated stock ○ 可备库存 Available stock ■ 推荐应用 Main application □ 拓展应用 Extended application

三面刀刃铣削刀具



PT05

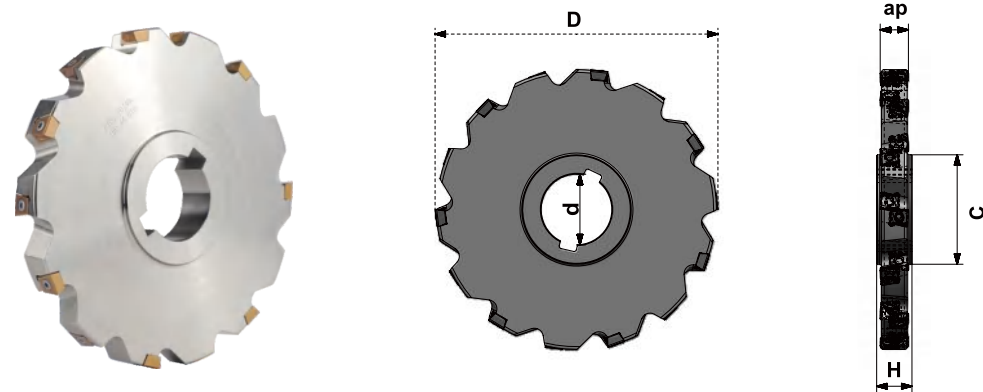

★ 刀具附件 Spare parts

刀片 Insert	刀片螺钉 Insert Screw	扳手 Wrench
LNGX1005□□-GM	TL60M3.5X10	T15
LNGX1407□□-GM	TL60M4X10	T15

注明：配套刀片与株洲钻石通用。Note: Replaceable with Zccct brand inserts.

★ 刀具规格型号 Type of Milling Tools

Category 类别	Type 型号	基本尺寸(mm) Dimension						Tooth 齿数	Adapter 接口 形式	Weight 重量(kg)
		ØD	Ød	ØC	H	ap	ae max			
10	PT05.10J27.080.08.H10	80	27	43	14	10	17	8	K	0.2
	PT05.10J32.100.10.H10	100	32	47	14	10	25	10	K	0.37
	PT05.10J40.125.12.H10	125	40	55	14	10	34	12	K	0.5
	PT05.10J40.160.14.H10	160	40	62	14	10	47	14	K	1
	PT05.10J50.200.16.H10	200	50	72	14	10	62	16	K	1.6
14	PT05.14J32.100.08.H12	100	32	47	16	12	25	8	K	0.4
	PT05.14J40.125.10.H12	125	40	55	16	12	34	10	K	0.6
	PT05.14J40.160.12.H12	160	40	62	16	12	47	12	K	1.1
10	PT05.14J50.200.14.H12	200	50	72	16	12	62	14	K	1.8
	PT05.10J32.100.10.H14	100	32	47	18	14	25	10	K	0.4
	PT05.10J40.125.12.H14	125	40	55	18	14	34	12	K	0.9
	PT05.10J40.160.14.H14	160	40	62	18	14	47	14	K	1.6
	PT05.10J50.200.16.H14	200	50	72	18	14	62	16	K	2.5

三面刀刃铣削刀具



★ 刀具规格型号 Type of Milling Tools

Category 类别	Type 型号	基本尺寸(mm) Dimension						Tooth 齿数	Adapter 接口 形式	Weight 重量(kg)
		ØD	Ød	ØC	H	ap	ae max			
10	PT05.10J40.125.12.H16	125	40	55	20	16	34	12	K	1
	PT05.10J40.160.14.H16	160	40	62	20	16	47	14	K	1.8
	PT05.10J50.200.16.H16	200	50	72	20	16	62	16	K	2.9
	PT05.10J40.125.12.H18	125	40	55	24	18	34	12	K	1.2
	PT05.10J40.160.14.H18	160	40	62	24	18	47	14	K	2.1
	PT05.10J50.200.16.H18	200	50	72	24	18	62	16	K	3.4
14	PT05.14J40.125.10.H20	125	40	55	26	20	34	10	K	1.2
	PT05.14J40.160.12.H20	160	40	62	26	20	47	12	K	2.1
	PT05.14J50.200.14.H20	200	50	72	26	20	62	14	K	3.5
	PT05.14J50.250.16.H20	250	50	80	26	20	83	16	K	5.8
	PT05.14J40.160.12.H25	160	40	62	30	25	47	12	K	2.8
	PT05.14J50.200.14.H25	200	50	72	30	25	62	14	K	4.5
	PT05.14J50.250.16.H25	250	50	80	30	25	83	16	K	7.5

三面刃铣削刀具



PT05

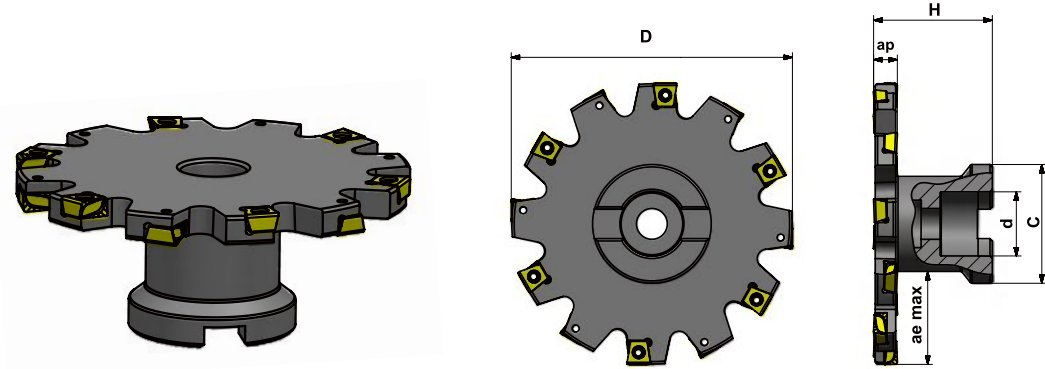

★ 刀具附件 Spare parts

刀片 Insert	刀片螺钉 Insert Screw	扳手 Wrench
LNGX1005□□-GM	TL60M3.5X10	T15
LNGX1407□□-GM	TL60M4X10	T15

注明：配套刀片与株洲钻石通用。 Note: Replaceable with Zccct brand inserts.

★ 刀具规格型号 Type of Milling Tools

Category 类别	Type 型号	基本尺寸(mm) Dimension						Tooth 齿数	Adapter 接口 形式	Weight 重量(kg)
		ØD	Ød	ØC	H	ap	ae max			
10	PT05.10A22.080.08.H10	80	22	45	40	10	20	8	A	0.4
	PT05.10B27.100.10.H10	100	27	55	45	10	24	10	B	0.6
	PT05.10B32.125.12.H10	125	32	65	45	10	33	12	B	1
	PT05.10B40.160.14.H10	160	40	80	50	10	42	14	B	2
	PT05.10C40.200.16.H10	200	40	92	50	10	53	16	C	2.9
14	PT05.14B27.100.08.H12	100	27	55	45	12	24	8	B	0.6
	PT05.14B32.125.10.H12	125	32	65	45	12	33	10	B	1
	PT05.14B40.160.12.H12	160	40	80	50	12	42	12	B	2.1
	PT05.14C40.200.14.H12	200	40	92	50	12	53	14	C	2.9
10	PT05.10B27.100.10.H14	100	27	55	50	14	24	10	B	0.7
	PT05.10B32.125.12.H14	125	32	65	50	14	33	12	B	1.2
	PT05.10B40.160.14.H14	160	40	80	50	14	42	14	B	2.4
	PT05.10C40.200.16.H14	200	40	92	50	14	53	16	C	3.6

三面刃铣削刀具



★ 刀具规格型号 Type of Milling Tools

Category 类别	Type 型号	基本尺寸(mm) Dimension						Tooth 齿数	Adapter 接口 形式	Weight 重量(kg)
		ØD	Ød	ØC	H	ap	ae max			
10	PT05.10B32.125.12.H16	125	32	65	50	16	33	12	B	1.4
	PT05.10B40.160.14.H16	160	40	80	50	16	42	14	B	2.6
	PT05.10C40.200.16.H16	200	40	92	50	16	53	16	C	4
	PT05.10B32.125.12.H18	125	32	65	50	18	33	12	B	1.5
	PT05.10B40.160.14.H18	160	40	80	50	18	42	14	B	2.9
	PT05.10C40.200.16.H18	200	40	92	50	18	53	16	C	4.3
	PT05.10C60.250.18.H18	250	60	132	50	18	58	18	C	7.2
14	PT05.14B32.125.10.H20	125	32	65	50	20	33	10	B	1.6
	PT05.14B40.160.12.H20	160	40	80	50	20	42	12	B	2.7
	PT05.14C40.200.14.H20	200	40	92	50	20	53	14	C	4.6
	PT05.14C60.250.16.H20	250	60	132	50	20	58	16	C	7.4
	PT05.14B40.160.12.H25	160	40	80	50	25	42	12	B	3.2
	PT05.14C40.200.14.H25	200	40	92	50	25	53	14	C	5.2
	PT05.14C60.250.16.H25	250	60	132	50	25	58	16	C	8.6
	PT05.14C60.315.20.H25	315	60	132	50	25	90	20	C	13.2

铣削刀具 | MILLING TOOLS



可转位铣削刀具 Indexable milling tools

倒角铣刀 Kr:45° Chamfer Milling Tools



AC01

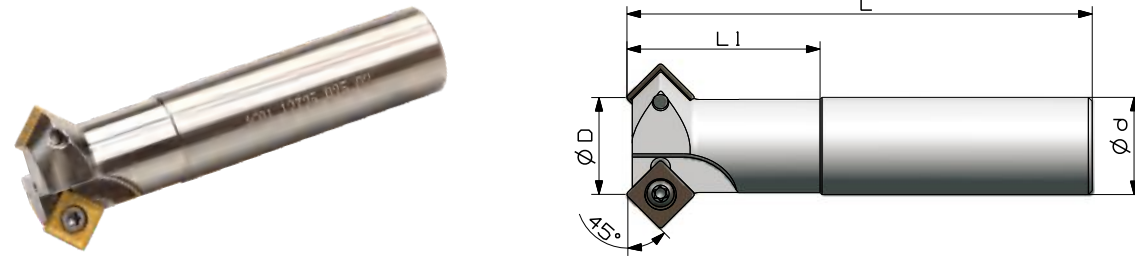

★ 刀具附件 Spare parts

刀片 Insert	刀片螺钉 Insert Screw	扳手 Wrench
SPMT120408	TL60 M5X12	T20

注明：配套刀片建议参考株洲钻石品牌刀片。 Note: The insert is Zccct brand.

★ 刀具规格型号 Type of Milling Tools

Type 型号	基本尺寸(mm) Dimension				Adapter 接口 形式	Tooth 齿数	Weight 重量(kg)
	ØD	Ød	L	L1			
AC01.12Z20.012.01	12	20	100	40	Z	1	0.2
AC01.12W20.012.01	12	20	100	40	W	1	0.2
AC01.12Z25.025.02	25	25	120	40	Z	2	0.4
AC01.12W25.025.02	25	25	120	40	W	2	0.4
AC01.12Z32.032.03	32	32	180	50	Z	3	1.0
AC01.12W32.032.03	32	32	180	50	W	3	1.0

了解具体库存情况请致电厂家 详情请登陆网站www.hnsant.com



铣削刀具 | MILLING TOOLS

可转位铣削刀具 Indexable milling tools

倒角铣刀 Kr:60° Chamfer Milling Tools



DC01

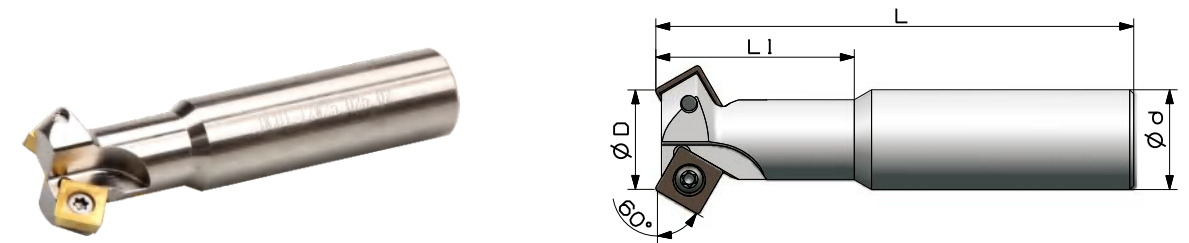

★ 刀具附件 Spare parts

刀片 Insert	刀片螺钉 Insert Screw	扳手 Wrench
SPMT120408	TL60 M5X12	T20

注明：配套刀片建议参考株洲钻石品牌刀片。 Note: The insert is Zccct brand.

★ 刀具规格型号 Type of Milling Tools

Type 型号	基本尺寸(mm) Dimension				Adapter 接口 形式	Tooth 齿数	Weight 重量(kg)
	ØD	Ød	L	L1			
DC01.12Z20.012.01	12	20	100	40	Z	1	0.2
DC01.12W20.012.01	12	20	100	40	W	1	0.2
DC01.12Z25.025.02	25	25	120	40	Z	2	0.4
DC01.12W25.025.02	25	25	120	40	W	2	0.4
DC01.12Z32.032.02	32	32	180	50	Z	2	1.0
DC01.12W32.032.02	32	32	180	50	W	2	1.0

了解具体库存情况请致电厂家 详情请登陆网站www.hnsant.com

铣削刀具 | MILLING TOOLS



可转位铣削刀具 Indexable milling tools

倒角铣刀 Kr:30° Chamfer Milling Tools



ZC01

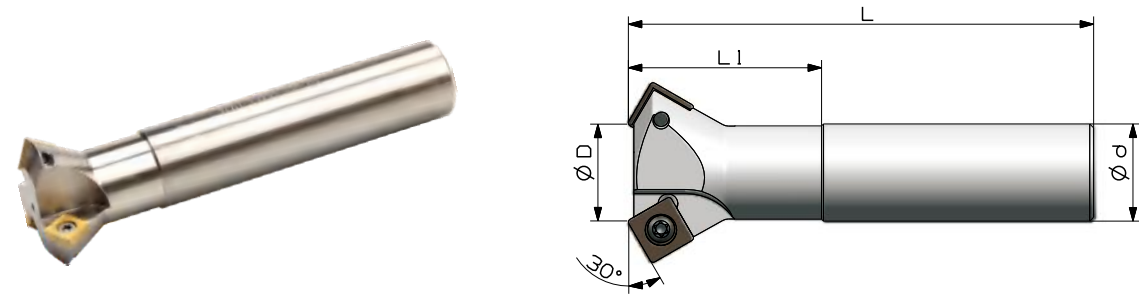

★ 刀具附件 Spare parts

刀片 Insert	刀片螺钉 Insert Screw	扳手 Wrench
SPMT120408	TL60 M5X12	T20

注明：配套刀片建议参考株洲钻石品牌刀片。 Note: The insert is Zccct brand.

★ 刀具规格型号 Type of Milling Tools

Type 型号	基本尺寸(mm) Dimension				Adapter 接口 形式	Tooth 齿数	Weight 重量(kg)
	ØD	Ød	L	L1			
ZC01.12Z20.012.01	12	20	100	40	Z	1	0.2
ZC01.12W20.012.01	12	20	100	40	W	1	0.2
ZC01.12Z25.025.02	25	25	120	40	Z	2	0.4
ZC01.12W25.025.02	25	25	120	40	W	2	0.4
ZC01.12Z32.032.03	32	32	180	50	Z	3	1.0
ZC01.12W32.032.03	32	32	180	50	W	3	1.0

了解具体库存情况请致电厂家 详情请登陆网站www.hnsant.com



铣削刀具 | MILLING TOOLS

Indexable milling tools 可转位铣削刀具

大进给刀具



XK01

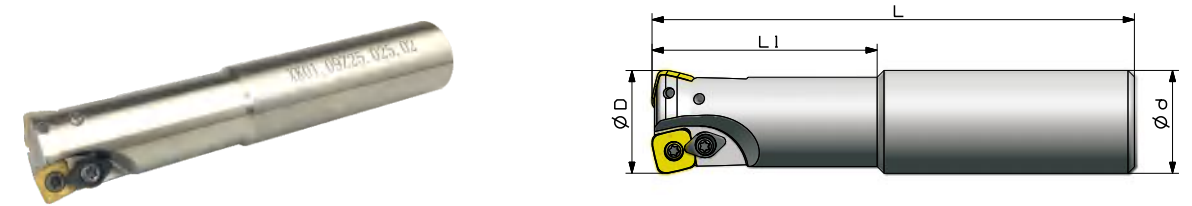

★ 刀具附件 Spare parts

刀片 Insert	刀片螺钉 Insert Screw	压板螺钉 Clamping Screw	压板 Clamp	扳手 Wrench
SDMT09T3-DM	TL60 M3.5X8	L60 M4X10	WD204	T10/T15
SDMT1204-DM	TL60 M4X10			T15

注明：配套刀片建议参考株洲钻石品牌刀片。 Note: The insert is Zccct brand.

★ 刀具规格型号 Type of Milling Tools

Type 型号	基本尺寸(mm) Dimension				Adapter 接口 形式	Tooth 齿数	Weight 重量(kg)
	ØD	Ød	L	L1			
XK01.09Z25.025.02	25	25	140	60	Z	2	0.5
XK01.09Z32.032.03	32	32	150	70	Z	3	0.8
XK01.09Z32.035.03	35	32	150	50	Z	3	0.8
XK01.12Z32.032.02	32	32	150	70	Z	2	0.8
XK01.12Z32.040.03	40	32	150	50	Z	3	1.3

了解具体库存情况请致电厂家 详情请登陆网站www.hnsant.com

大进给刀具

XK01

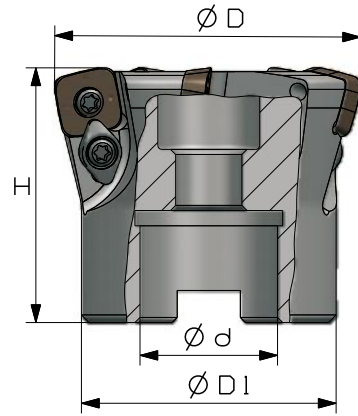

★ 刀具附件 Spare parts

刀片 Insert	刀片螺钉 Insert Screw	压板螺钉 Clamping Screw	压板 Clamp	扳手 Wrench
SDMT09T3-DM	TL60 M3.5X8	L60 M4X10	WD204	T10T/T15T
SDMT1204-DM	TL60 M4X10			T15T

注明：配套刀片建议参考株洲钻石品牌刀片。 Note: The insert is Zccct brand.

★ 刀具规格型号 Type of Milling Tools

Type 型号	基本尺寸(mm) Dimension				Adapter 接口 形式	Tooth 齿数	Weight 重量(kg)
	ØD	ØD1	Ød	H			
XK01.09A22.050.04	50	40	22	40	A	4	0.3
XK01.09A22.063.06	63	50	22	50	A	6	0.5
XK01.09A27.063.06	63	50	27	50	A	6	0.6
XK01.12A22.063.05	63	50	22	50	A	5	0.5
XK01.12A27.063.05	63	50	27	50	A	5	0.6
XK01.12A27.080.05	80	60	27	50	A	5	0.9
XK01.12B32.100.06	100	70	32	50	B	6	1.8

大进给刀具

XK02

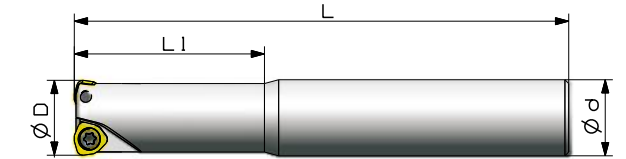

★ 刀具附件 Spare parts

刀片 Insert	刀片螺钉 Insert Screw	压板螺钉 Clamping Screw	压板 Clamp	扳手 Wrench
WPGT050315ZSR	TL60 M3.5X8			T10
WPGT060415ZSR	TL60M4X10			T15
WPGT080615ZSR	TL60 M4X10	L60 M5X12	WD208	T20
WPGT090725ZSR				

注明：配套刀片建议参考株洲钻石品牌刀片。 Note: The insert is Zccct brand.

★ 刀具规格型号 Type of Milling Tools

Category 类型	Type 型号	基本尺寸(mm) Dimension				Adapter 接口 形式	Tooth 齿数	Weight 重量(kg)
		ØD	Ød	L	L1			
WP05	XK02.05Z20.020.02.S	20	20	130	50	Z	2	0.2
	XK02.05Z20.020.02.M	20	20	180	100	Z	2	0.3
	XK02.05Z20.020.02.L	20	20	250	130	Z	2	0.8
WP06	XK02.06Z25.025.02.S	25	25	140	60	Z	2	0.4
	XK02.06Z25.025.02.M	25	25	200	120	Z	2	0.6
	XK02.06Z25.025.02.L	25	25	300	180	Z	2	1.0
	XK02.06Z32.032.03.S	32	32	150	70	Z	3	0.8
	XK02.06Z32.032.03.M	32	32	200	120	Z	3	1.0
	XK02.06Z32.032.03.L	32	32	300	180	Z	3	1.6
	XK02.06Z32.040.03.S	40	32	150	50	Z	3	0.9

大进给刀具



★ 刀具规格型号 Type of Milling Tools

Category 类型	Type 型号	基本尺寸(mm) Dimension				Adapter 接口 形式	Tooth 齿数	Weight 重量(kg)
		ØD	Ød	L	L1			
WP06	XK02.06Z32.040.03.M	40	32	250	50	Z	3	1.5
	XK02.06Z32.040.03.L	40	32	300	50	Z	3	1.8
WP08	XK02.08Z32.040.02.S	40	32	150	50	Z	2	0.9
	XK02.08Z32.040.02.M	40	32	250	50	Z	2	1.5
	XK02.08Z32.040.02.L	40	32	300	50	Z	2	1.9
WP09	XK02.09Z32.050.02.S	50	32	150	50	Z	2	1.9
	XK02.09Z32.050.02.M	50	32	250	50	Z	2	2.5

大进给刀具



XK02

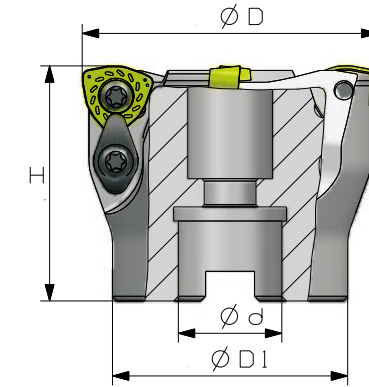

★ 刀具附件 Spare parts

刀片 Insert	刀片螺钉 Insert Screw	压板螺钉 Clamping Screw	压板 Clamp	扳手 Wrench
WPGT060415ZSR	TL60 M4X10			T15T
WPGT080615ZSR	TL60 M5X12	TL60 M5X12	WD208	T20T
WPGT090725ZSR				

注明：配套刀片建议参考株洲钻石品牌刀片。 Note: The insert is Zccot brand.

★ 刀具规格型号 Type of Milling Tools

Category 类型	Type 型号	基本尺寸(mm) Dimension				Adapter 接口 形式	Tooth 齿数	Weight 重量(kg)
		ØD	ØD1	Ød	H			
WP06	XK02.06A22.050.04	50	40	22	50	A	4	0.4
	XK02.08A22.050.03	50	40	22	50	A	3	0.4
	XK02.08A22.063.04	63	50	22	50	A	4	0.7
WP08	XK02.08A27.063.04	63	50	27	50	A	4	0.7
	XK02.08A27.080.05	80	60	27	50	A	5	1.5
	XK02.08B32.100.06	100	70	32	63	B	6	2.2
	XK02.08B40.125.07	125	80	40	63	B	7	3.5
	XK02.08B40.160.08	160	100	40	63	B	8	6.0
WP09	XK02.09A22.063.03	63	50	22	50	A	3	0.7
	XK02.09A27.080.04	80	60	27	63	A	4	1.4
	XK02.09B32.100.05	100	70	32	63	B	5	2.1
	XK02.09B40.125.06	125	80	40	63	B	6	3.7
	XK02.09B40.160.07	160	100	40	63	B	7	6.3

可转位铣削刀具 Indexable milling tools

大进给刀具

XK03

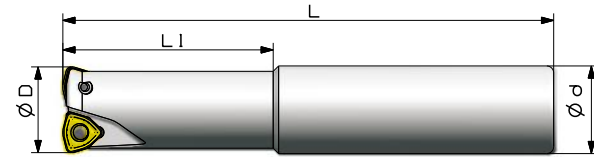

★ 刀具附件 Spare parts

刀片 Insert 	刀片螺钉 Insert Screw 	扳手 Wrench
WNMX09T316ZNN-MM	TL60 M3X7	T10

注明：配套刀片建议参考克洛伊品牌刀片。 Note: The insert is Korloy brand.

★ 刀具规格型号 Type of Milling Tools

Type 型号	基本尺寸(mm) Dimension				Adapter 接口 形式	Tooth 齿数	Weight 重量(kg)
	ØD	Ød	L	L1			
XK03.09Z25.025.02.S	25	25	140	60	Z	2	0.5
XK03.09Z25.025.02.M	25	25	200	120	Z	2	0.6
XK03.09Z25.025.02.L	25	25	300	180	Z	2	1.0
XK03.09Z32.032.03.S	32	32	150	70	Z	3	0.8
XK03.09Z32.032.03.M	32	32	200	120	Z	3	1.1
XK03.09Z32.032.03.L	32	32	300	180	Z	3	1.7
XK03.09Z32.040.04.S	40	32	150	50	Z	4	0.9
XK03.09Z32.040.04.M	40	32	200	50	Z	4	1.3
XK03.09Z32.040.04.L	40	32	300	50	Z	4	1.8

了解具体库存情况请致电厂家 详情请登陆网站www.hnsant.com

可转位铣削刀具 Indexable milling tools

大进给刀具

XK03

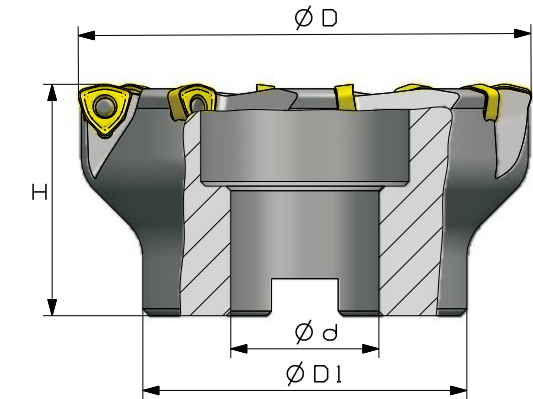
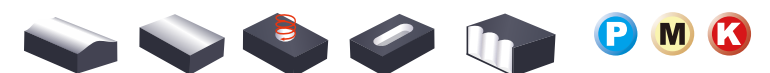

★ 刀具附件 Spare parts

刀片 Insert 	刀片螺钉 Insert Screw 	扳手 Wrench
WNMX09T316ZNN-MM	TL60 M3X7	T10T

注明：配套刀片建议参考克洛伊品牌刀片。 Note: The insert is Korloy brand.

★ 刀具规格型号 Type of Milling Tools

Type 型号	基本尺寸(mm) Dimension				Adapter 接口 形式	Tooth 齿数	Weight 重量(kg)
	ØD	ØD1	Ød	H			
XK03.09A16.040.04	40	35	16	40	A	4	0.2
XK03.09A22.050.05	50	40	22	40	A	5	0.3
XK03.09A22.063.06	63	50	22	40	A	6	0.5
XK03.09A27.080.07	80	60	27	50	A	7	1.1
XK03.09B32.100.08	100	70	32	50	B	8	1.7

了解具体库存情况请致电厂家 详情请登陆网站www.hnsant.com

大进给刀具

XK04

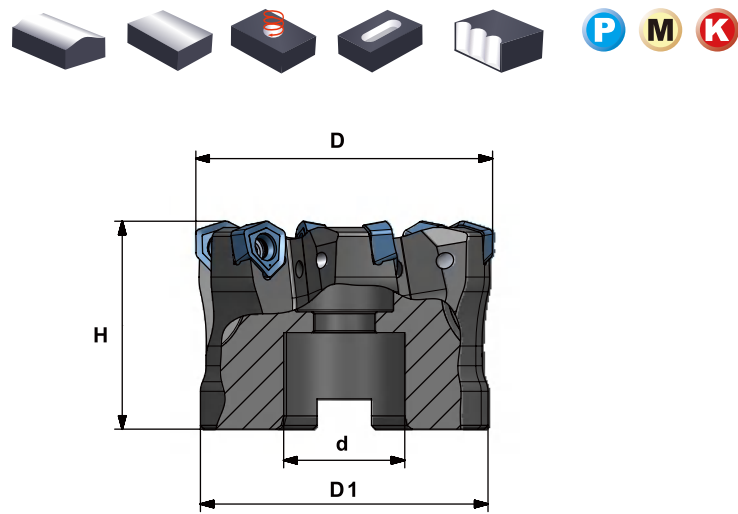

★ 刀具附件 Spare parts

刀片 Insert 	压紧螺钉 Clamping Screw 	扳手 Wrench
WXMU080612R-GM	TL60M5X13	T20

注明：配套刀片与株钻、伊斯卡通用。Note: Replaceable with Zccct/Iscar brand inserts.

★ 刀具规格型号 Type of milling tools

Type 型号	基本尺寸(mm) Dimension					Adapter 接口 形式	Tooth 齿数	Weight 重量 (kg)
	ØD ₁	ØD	Ød	H	ap			
XK04.08A22.050.04	48	50	22	45	2.0	A	4	0.3
XK04.08A22.063.05	61	63	22	45	2.0	A	5	0.5
XK04.08A32.080.06	76	80	32	55	2.0	A	6	1.1
XK04.08B32.100.07	80	100	32	50	2.0	A	7	1.75

★ 刀片选择 Matching Insert

型号 Type	SP210M	SD2136	SD2336	SD4326	SD4226	SD4236	SD5346	SD5236	SD5450	SD5440	基本尺寸(mm) Dimension			
											φIC	S	φd	r
WXMU080612R-GM	●										13.66	6.8	5.5	1.2
P 钢	<input type="checkbox"/>													
M 不锈钢	<input type="checkbox"/>													
K 铸铁	<input checked="" type="checkbox"/>													
N 有色金属														
S 耐热合金、钛合金														
H 淬硬材料														

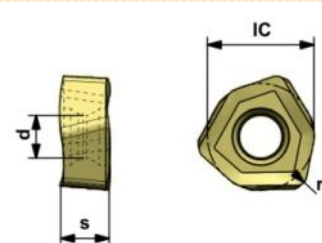

● 常备库存 Unallocated stock ○ 可备库存 Available stock ■ 推荐应用 Main application □ 拓展应用 Extended application

了解具体库存情况请致电厂家 详情请登陆网站www.hnsant.com

大进给刀具

EXN

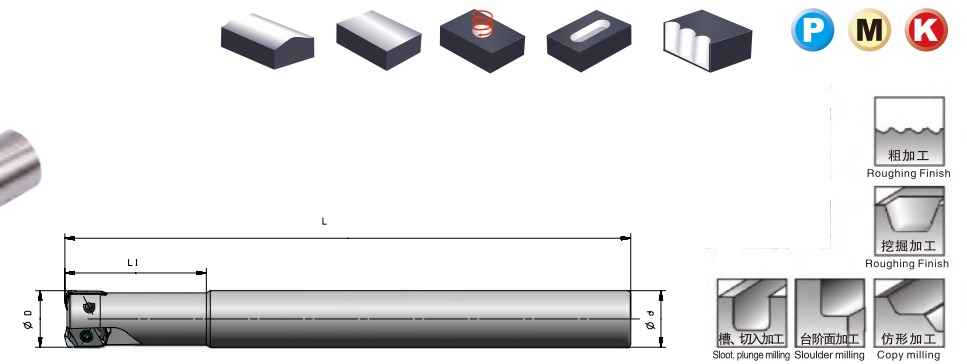

★ 刀具规格型号 Type of Milling Tools

标准库品 Stocked Letms	型号 Cat.No	尺寸 Size					刃数 Flute	适用刀片 Applicable inserts	扳手 Wrench	螺钉 Screw	
		ØD	ØD ₁	Ød	L ₁	L					ap
EXN03R-16-100-C16-2T		16	9.6	16	35	100	1	2			
EXN03R-16-160-C16-2T		16	9.6	16	40	160	1	2			
EXN03R-17-100-C16-2T		17	10.5	16	35	100	1	2			
EXN03R-17-160-C16-2T		17	10.5	16	40	160	1	2			
EXN03R-18-100-C16-2T		18	11.5	16	35	100	1	2			
EXN03R-18-160-C16-2T		18	11.5	16	40	160	1	2			
EXN03R-20-130-C20-3T		20	13.5	20	40	130	1	3			
EXN03R-20-160-C20-3T		20	13.5	20	45	160	1	3			
EXN03R-21-130-C20-3T		21	14.5	20	40	130	1	3			
EXN03R-21-160-C20-3T		21	14.5	20	50	160	1	3			
EXN03R-22-130-C20-3T		22	15.5	20	40	130	1	3			
EXN03R-22-200-C20-3T		22	15.5	20	50	200	1	3	LNMU0303ZER	T08	M2.5X6.5
EXN03R-25-160-C25-4T		25	18.5	25	50	160	1	3			
EXN03R-25-200-C25-4T		25	18.5	25	60	200	1	4			
EXN03R-26-160-C25-4T		26	19.5	25	50	160	1	4			
EXN03R-26-200-C25-4T		26	19.5	25	60	200	1	4			
EXN03R-28-160-C25-4T		28	21.5	25	50	160	1	4			
EXN03R-28-200-C25-4T		28	21.5	25	60	200	1	4			
EXN03R-30-160-C32-5T		30	23.5	32	50	160	1	5			
EXN03R-30-200-C32-5T		30	23.5	32	60	200	1	5			
EXN03R-32-160-C32-5T		32	25.5	32	50	160	1	5			
EXN03R-32-200-C32-5T		32	25.5	32	60	200	1	5			
EXN03R-35-160-C32-5T		35	28.5	32	45	160	1	5			
EXN03R-35-200-C32-5T		35	28.5	32	45	200	1	5			

备注：与东芝品牌刀片通用。Note: Replaceable with Tungaloy brand inserts.

了解具体库存情况请致电厂家 详情请登陆网站www.hnsant.com

模具铣削刀具 | MOLD MILLING TOOLS



可转位铣削刀具 Indexable milling tools

大进给刀具

EXN

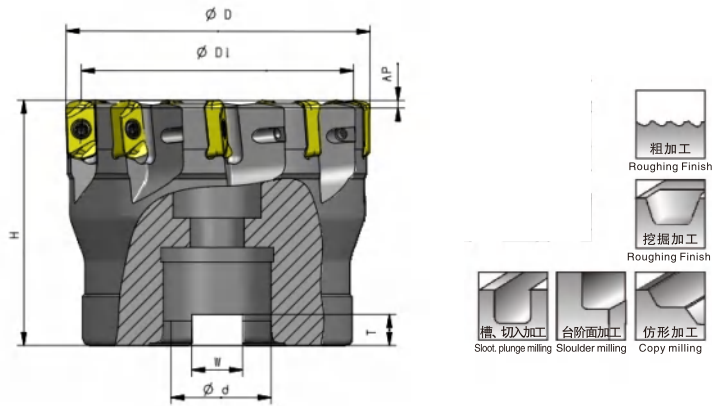

★ 刀具规格型号 Type of Milling Tools

标准备库品 Stocked Letms	型号 Cat.No	尺寸 Size						齿数 Teeth	适用刀片 Applicable inserts	扳手 Wrench	螺钉 Screw
		ØD	ØD1	Ød	H	W	ap				
	EXN03R-040-A16-6T	40	33.6	16	40	8.4	1	5.5	6		
	EXN03R-050-A22-8T	50	43.6	22	50	10.4	1	6.3	8		
	EXN03R-063-A22-9T	63	56.6	22	50	10.4	1	6.3	9	LNMU0303ZER	T08
	EXN03R-080-A27-10T	80	73.6	27	50	12.4	1	6.3	10		M2.5X6.5

备注：与东芝品牌刀片通用。Note: Replaceable with Tungaloy brand inserts.

★ 刀片选择 Matching Insert

型号 Type	基本尺寸(mm) Dimension														
	SD1325Z	SD1525Z	SD2136	SD2336	SD4326	SD4226	SD4236	SD6346	SD6236	SD5450	L	φIC	S	φd	r
LNMU0303ZER	●	●	●	●			●			●	11.39	6	4.29	2.8	1.2
P 钢	■	■	■	■						■					
M 不锈钢	■	■	□	■											
K 铸铁	■	■		■			■			■					
N 有色金属															
S 耐热合金、钛合金															
H 淬硬材料															

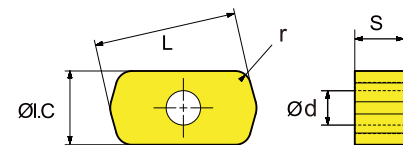

● 常备库存 Unallocated stock ○ 可备库存 Available stock ■ 推荐应用 Main application □ 拓展应用 Extended application

了解具体库存情况请致电厂家 详情请登陆网站www.hnsant.com



模具铣削刀具 | MOLD MILLING TOOLS

Indexable milling tools 可转位铣削刀具

大进给刀具 Kr:90°

TE90

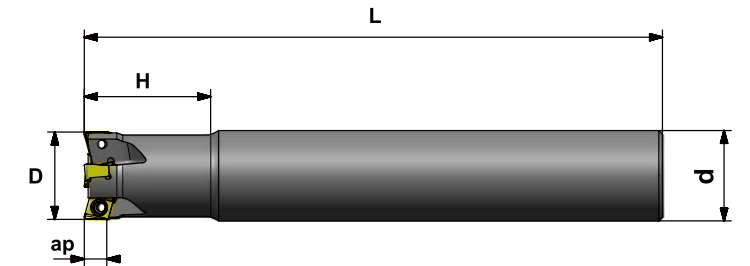
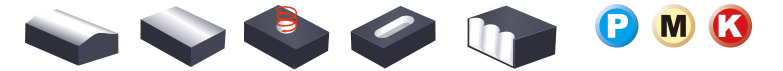

★ 刀具附件 Spare parts

刀片 Insert	刀片螺钉 Insert Screw	扳手 Wrench
4NKT060308	TL60M3X8	T10

注明：配套刀片与特固克品牌刀片通用。Note: Replaceable with Taegutec brand inserts.

★ 刀具规格型号 Type of Milling Tools

Type 型号	基本尺寸(mm) Dimension					Adapter 接口 形式	Tooth 齿数
	Ød	ØD	L	H	ap		
TE90.06D16.016.02.L100	16	16	100	25	6	Z	2
TE90.06D16.016.02.L160	16	16	160	25	6	Z	2
TE90.06D20.020.03.L110	20	20	110	25	6	Z	3
TE90.06D20.020.03.L160	20	20	160	25	6	Z	3
TE90.06D20.020.03.L200	20	20	200	25	6	Z	3
TE90.06D25.025.04.L160	25	25	160	30	6	Z	4
TE90.06D25.025.04.L200	25	25	200	30	6	Z	4
TE90.06D32.032.05.L160	32	32	160	35	6	Z	5
TE90.06D32.032.05.L200	32	32	200	35	6	Z	5
TE90.06D32.035.05.L160	32	35	160	35	6	Z	5
TE90.06D32.035.05.L200	32	35	200	35	6	Z	5
TE90.06D32.040.06.L160	32	40	160	40	6	Z	6
TE90.06D32.040.06.L200	32	40	200	40	6	Z	6
TE90.06D32.040.06.L250	32	40	250	40	6	Z	6

了解具体库存情况请致电厂家 详情请登陆网站www.hnsant.com

铣削刀具 | MILLING TOOLS



可转位铣削刀具 Indexable milling tools

大进给刀具 Kr:90°

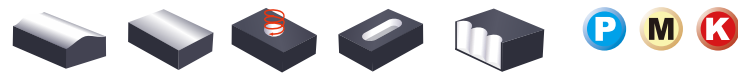

TE90

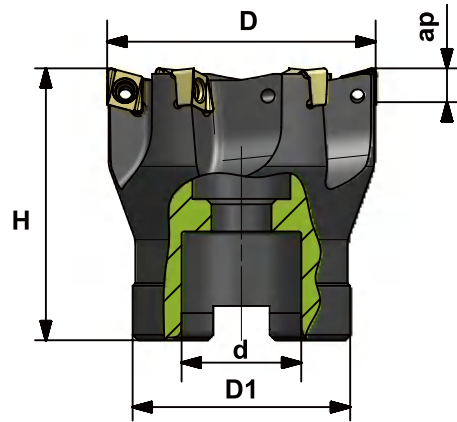

★ 刀具附件 Spare parts

刀片 Insert	刀片螺钉 Insert Screw	扳手 Wrench
4NKT060308	TL60M2.5X6.5	T08

注明：配套刀片与特固克品牌刀片通用。 Note: Replaceable with Taegutec brand inserts.

★ 刀具规格型号 Type of Milling Tools

Type 型号	基本尺寸(mm) Dimension					Adapter 接口 形式	Tooth 齿数	Weight 重量 (g)
	ØD ₁	ØD	Ød	H	ap			
TE90.06A22.050.06	40	50	22	50	6.0	A	6	0.4
TE90.06A22.063.08	50	63	22	50	6.0	A	8	0.6
TE90.06A27.080.10	60	80	27	50	6.0	A	10	1.0

★ 刀片选择 Matching Insert

型号 Type	SD1525	SD2136	SD2336	SD4326	SD4226	SD5346	SD5236	SD5450	SD6440	SD5146	基本尺寸(mm) Dimension				
											d	d1	t	ap	r
4NKT060308R	●	○	○								6.6	6.6	4.6	5.5	0.8

- P** 钢
- M** 不锈钢
- K** 铸铁
- N** 有色金属
- S** 耐热合金、钛合金
- H** 淬硬材料

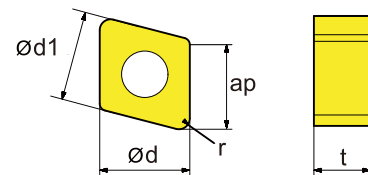

● 常备库存 Unallocated stock ○ 可备库存 Available stock ■ 推荐应用 Main application □ 拓展应用 Extended application

了解具体库存情况请致电厂家 详情请登陆网站www.hnsant.com

铣削刀具 | MILLING TOOLS



Indexable milling tools 可转位铣削刀具

螺旋立铣刀 Kr:90°

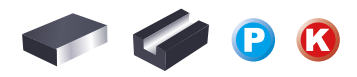

PH01

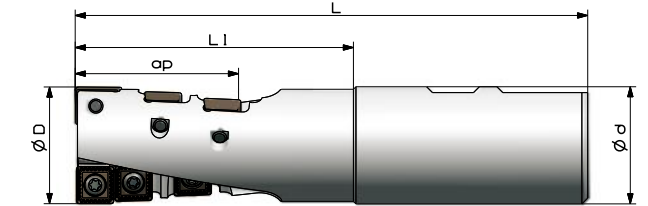
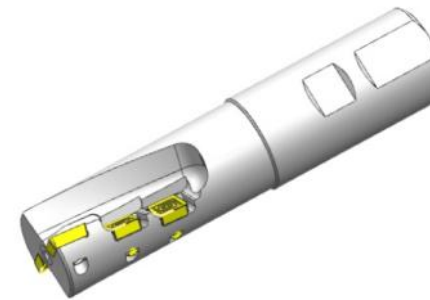

★ 刀具附件 Spare parts

刀片 Insert	侧切刀片 Side Cutting Insert	刀片螺钉 Insert Screw	扳手 Wrench
APKT150412	SPMT120408	TL60 M5X12	T20

注明：配套刀片建议参考株洲钻石。 Note: The Insert Is Zccct brand.

★ 刀具规格型号 Type of Milling Tools

Type 型号	基本尺寸(mm) Dimension					Adapter 接口 形式	Tooth 齿数	Weight 重量(kg)
	ØD	Ød	L	L1	ap			
PH01.12W40.040.02.E55	40	40	175	95	55	W	02	1.2
PH01.12W40.050.04.E55	50	40	175	95	55	W	04	1.5

了解具体库存情况请致电厂家 详情请登陆网站www.hnsant.com

铣削刀具 | MILLING TOOLS



可转位铣削刀具 Indexable milling tools

螺旋立铣刀 Kr:90°

PH01

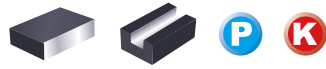
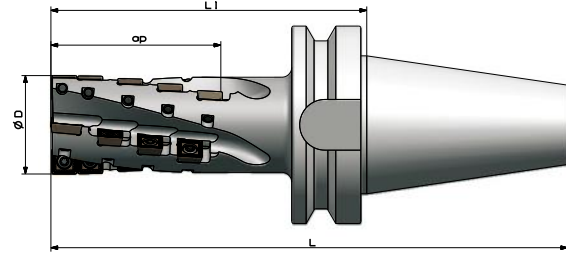
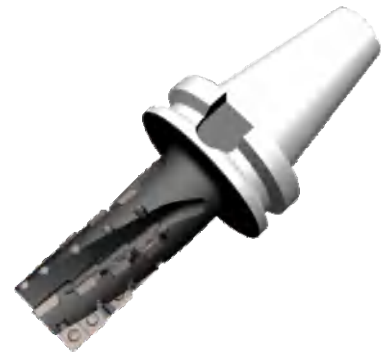

★ 刀具附件 Spare parts

底切刀片	侧切刀片 Side Cutting Insert	刀片螺钉 Insert Screw	扳手 Wrench
APKT150412	SPMT120408	TL60 M5X12	T20T

注明：刀片为株洲钻石品牌刀片。 Note: The insert is Zccct brand.

★ 刀具规格型号 Type of Milling Tools

Category 类型	Type 型号	基本尺寸(mm) Dimension				Adapter 接口 形式	Tooth 齿数	Weight 重量 (kg)
		ØD	L	L1	ap			
JT50	PH01.12JT50.050.04.084	50	246.75	145	84	JT50	4	4.8
	PH01.12JT50.063.04.074	63	236.75	135	74	JT50	4	5.5
	PH01.12JT50.063.04.104	63	266.75	165	104	JT50	4	6.0
	PH01.12JT50.063.04.134	63	296.75	195	134	JT50	4	6.3
	PH01.12JT50.080.04.104	80	266.75	165	104	JT50	4	7.0
	PH01.12JT50.080.04.144	80	306.75	205	144	JT50	4	7.2
BT50	PH01.12BT50.050.04.084	50	246.75	145	84	BT50	4	4.8
	PH01.12BT50.063.04.074	63	236.75	135	74	BT50	4	5.5
	PH01.12BT50.063.04.104	63	266.75	165	104	BT50	4	6.0
	PH01.12BT50.063.04.134	63	296.75	195	134	BT50	4	6.3
	PH01.12BT50.080.04.104	80	266.75	165	104	BT50	4	7.0
	PH01.12BT50.080.04.144	80	306.75	205	144	BT50	4	7.2

了解具体库存情况请致电厂家 详情请登陆网站www.hnsant.com



模具铣削刀具 | MOLD MILLING TOOLS

Indexable milling tools 可转位铣削刀具

BAP 直角台阶铣刀

BAP right angel shouder end mill

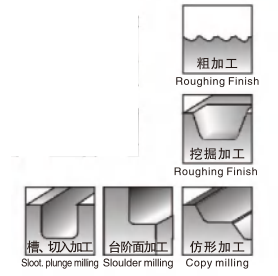
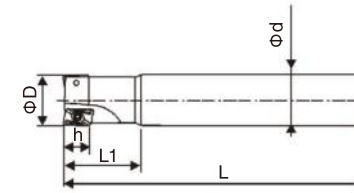

标准品 Stocked Letms	型号 Cat.No	尺寸 Size						适用刀片 Applicable inserts	齿数 Teeth	扳手 Screw	螺钉 Pressure plate
		ØD	Ød	L	L1	L2	h				
BAP300R-10-130-C10-1T		10	10	130	30	-	9	APMT1135PDER	1	T08	M2.5X5
BAP300R-11-130-C10-1T		11	10	130	30	-	9	APMT1135PDER	1	T08	M2.5X5
BAP300R-12-130-C12-1T		12	12	130	30	-	9	APMT1135PDER	1	T08	M2.5X5
BAP300R-13-130-C12-1T		13	12	130	30	-	9	APMT1135PDER	1	T08	M2.5X5
BAP300R-16-130-C16-2T		16	16	130	40	-	9	APMT1135PDER	2	T08	M2.5X5
BAP300R-16-160-C16-2T		16	16	160	40	-	9	APMT1135PDER	2	T08	M2.5X5
BAP300R-16-200-C16-2T		16	16	200	40	100	9	APMT1135PDER	2	T08	M2.5X5
BAP300R-17-160-C16-2T		17	16	160	40	-	9	APMT1135PDER	2	T08	M2.5X5
BAP300R-17-200-C16-2T		17	16	200	40	-	9	APMT1135PDER	2	T08	M2.5X5
BAP300R-20-130-C20-2T		20	20	130	40	-	9	APMT1135PDER	2	T08	M2.5X5
BAP300R-20-160-C20-2T		20	20	160	50	-	9	APMT1135PDER	2	T08	M2.5X5
BAP300R-20-200-C20-2T		20	20	200	50	100	9	APMT1135PDER	2	T08	M2.5X5
BAP300R-21-160-C20-2T		21	20	160	50	-	9	APMT1135PDER	2	T08	M2.5X5
BAP300R-21-200-C20-2T		21	20	200	50	-	9	APMT1135PDER	2	T08	M2.5X5
BAP300R-25-160-C25-2T		25	25	160	50	-	9	APMT1135PDER	2	T08	M2.5X5
BAP300R-25-200-C25-2T		25	25	200	50	-	9	APMT1135PDER	2	T08	M2.5X5
BAP300R-26-160-C25-2T		26	25	160	50	-	9	APMT1135PDER	2	T08	M2.5X5
BAP300R-26-200-C25-2T		26	25	200	50	-	9	APMT1135PDER	2	T08	M2.5X5
BAP400R											
BAP400R-25-160-C25-2T		25	25	160	50	-	14	APMT1604PDER	2	T15	M4X8
BAP400R-25-200-C25-2T		25	25	200	75	-	14	APMT1604PDER	2	T15	M4X8
BAP400R-25-250-C25-2T		25	25	250	50	-	14	APMT1604PDER	2	T15	M4X8
BAP400R-26-160-C25-2T		26	25	160	40	-	14	APMT1604PDER	2	T15	M4X8
BAP400R-26-200-C25-2T		26	25	200	50	-	14	APMT1604PDER	2	T15	M4X8
BAP400R-26-250-C25-2T		26	25	250	50	-	14	APMT1604PDER	2	T15	M4X8
BAP400R-32-160-C25-2T		32	25	160	50	-	14	APMT1604PDER	2	T15	M4x8
BAP400R-32-200-C25-2T		32	25	200	50	-	14	APMT1604PDER	2	T15	M4x8
BAP400R-32-160-C32-3T		32	32	160	50	-	14	APMT1604PDER	3	T15	M4x8
BAP400R-32-200-C32-3T		32	32	200	80	-	14	APMT1604PDER	3	T15	M4x8
BAP400R-32-250-C32-3T		32	32	250	60	115	14	APMT1604PDER	3	T15	M4x8
BAP400R-32-300-C32-3T		32	32	300	60	165	14	APMT1604PDER	3	T15	M4x8
BAP400R-35-160-C32-3T		35	32	160	50	-	14	APMT1604PDER	3	T15	M4X8
BAP400R-35-200-C32-3T		35	32	200	60	-	14	APMT1604PDER	3	T15	M4X8
BAP400R-35-250-C32-3T		35	32	250	60	-	14	APMT1604PDER	3	T15	M4X8
BAP400R-35-300-C32-3T		35	32	300	60	-	14	APMT1604PDER	3	T15	M4X8
BAP400R-35-350-C32-3T		35	32	350	60	-	14	APMT1604PDER	3	T15	M4X8
BAP400R-35-400-C32-3T		35	32	400	60	-	14	APMT1604PDER	3	T15	M4X8
BAP400R-40-200-C32-3T		40	32	200	60	-	14	APMT1604PDER	3	T15	M4X8
BAP400R-40-250-C32-3T		40	32	250	60	-	14	APMT1604PDER	3	T15	M4X8
BAP400R-40-300-C32-3T		40	32	300	60	-	14	APMT1604PDER	3	T15	M4X8
BAP400R-40-350-C32-3T		40	32	350	60	-	14	APMT1604PDER	3	T15	M4X8
BAP400R-40-400-C32-3T		40	32	400	60	-	14	APMT1604PDER	3	T15	M4X8

备注：配套刀片建议参照三菱、株洲钻石牌刀片。
Note: Matching insert we suggest Mitsubishi Zccct brand

了解具体库存情况请致电厂家 详情请登陆网站www.hnsant.com

模具铣削刀具 | MOLD MILLING TOOLS



可转位铣削刀具 Indexable milling tools

EMR 圆鼻立铣刀

EMR round dowel end mill

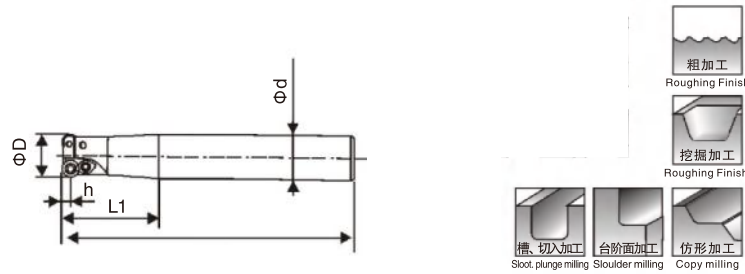

标准备库品 Stocked Letms	型号 Cat.No	尺寸 Size						适用刀片 Applicable inserts	齿数 Teeth	扳手 Wrench	螺钉 Screw	压板 Pressure plate
		ϕD	ϕd	L	L1	L2	h					
EMR-4R-12-130-C12-1T		12	12	130	40	-	4	RPMW0802 M0	1	T10	M3X7	-
EMR-4R-13-130-C12-1T		13	12	130	40	-	4	RPMW0802 M0	1	T10	M3X7	-
EMR-4R-16-130-C16-2T		16	16	130	40	-	4	RPMW0802 M0	2	T10	M3X7	WD-202
EMR-4R-16-160-C16-2T		16	16	160	40	-	4	RPMW0802 M0	2	T10	M3X7	WD-202
EMR-4R-16-200-C16-2T		16	16	200	40	100	4	RPMW0802 M0	2	T10	M3X7	WD-202
EMR-4R-17-160-C16-2T		17	16	160	40	-	4	RPMW0802 M0	2	T10	M3X7	WD-202
EMR-4R-17-200-C16-2T		17	16	200	40	-	4	RPMW0802 M0	2	T10	M3X7	WD-202
EMR-4R-20-160-C20-2T		20	20	160	50	-	4	RPMW0802 M0	2	T10	M3X7	WD-202
EMR-4R-20-200-C20-2T		20	20	200	50	100	4	RPMW0802 M0	2	T10	M3X7	WD-202
EMR-4R-21-160-C20-2T		21	20	160	50	-	4	RPMW0802 M0	2	T10	M3X7	WD-202
EMR-4R-21-200-C20-2T		21	20	200	50	-	4	RPMW0802 M0	2	T10	M3X7	WD-202
EMR-5R-20-160-C20-2T		20	20	160	50	-	5	RPMW1003 M0	2	T15	M4X10	WD-204
EMR-5R-20-200-C20-2T		20	20	200	50	100	5	RPMW1003 M0	2	T15	M4X10	WD-204
EMR-5R-21-160-C20-2T		21	20	160	50	-	5	RPMW1003 M0	2	T15	M4X10	WD-204
EMR-5R-21-200-C20-2T		21	20	200	50	-	5	RPMW1003 M0	2	T15	M4X10	WD-204
EMR-5R-25-160-C20-2T		25	20	160	50	-	5	RPMW1003 M0	2	T15	M4X10	WD-204
EMR-5R-25-160-C25-2T		25	25	160	50	-	5	RPMW1003 M0	2	T15	M4X10	WD-204
EMR-5R-25-200-C25-2T		25	25	200	75	-	5	RPMW1003 M0	2	T15	M4X10	WD-204
EMR-5R-25-250-C25-2T		25	25	250	60	115	5	RPMW1003 M0	2	T15	M4X10	WD-204
EMR-5R-30-160-C25-2T		30	25	160	50	-	5	RPMW1003 M0	2	T15	M4X10	WD-204
EMR-5R-30-200-C25-2T		30	25	200	50	-	5	RPMW1003 M0	2	T15	M4X10	WD-204
EMR-5R-30-250-C25-2T		30	25	250	60	-	5	RPMW1003 M0	2	T15	M4X10	WD-204
EMR-5R-30-300-C25-2T		30	25	300	60	-	5	RPMW1003 M0	2	T15	M4X10	WD-204
EMR-5R-35-160-C32-2T		35	32	160	50	-	5	RPMW1003 M0	2	T15	M4X10	WD-204
EMR-5R-35-200-C32-2T		35	32	200	50	-	5	RPMW1003 M0	2	T15	M4X10	WD-204
EMR-5R-35-160-C32-3T		35	32	160	50	-	5	RPMW1003 M0	3	T15	M4X10	WD-204
EMR-5R-35-200-C32-3T		35	32	200	50	-	5	RPMW1003 M0	3	T15	M4X10	WD-204
EMR-5R-35-250-C32-3T		35	32	250	60	-	5	RPMW1003 M0	3	T15	M4X10	WD-204
EMR-5R-35-300-C32-3T		35	32	300	60	-	5	RPMW1003 M0	3	T15	M4X10	WD-204
EMR-5R-35-350-C32-3T		35	32	350	60	-	5	RPMW1003 M0	3	T15	M4X10	WD-204
EMR-5R-40-200-C32-4T		40	32	200	50	-	5	RPMW1003 M0	4	T15	M4X10	WD-204
EMR-5R-40-250-C32-4T		40	32	250	60	-	5	RPMW1003 M0	4	T15	M4X10	WD-204
EMR-5R-40-300-C32-4T		40	32	300	60	-	5	RPMW1003 M0	4	T15	M4X10	WD-204
EMR-5R-40-350-C32-4T		40	32	350	60	-	5	RPMW1003 M0	4	T15	M4X10	WD-204

备注：配套刀片建议参照三菱、株洲钻石、特固克牌刀片。 Note: Matching insert we suggest Mitsubishi, Zccct brand.

了解具体库存情况请致电厂家 详情请登陆网站www.hnsant.com

模具铣削刀具 | MOLD MILLING TOOLS



Indexable milling tools 可转位铣削刀具

EMRW 圆鼻立铣刀

EMRW round dowel end mill

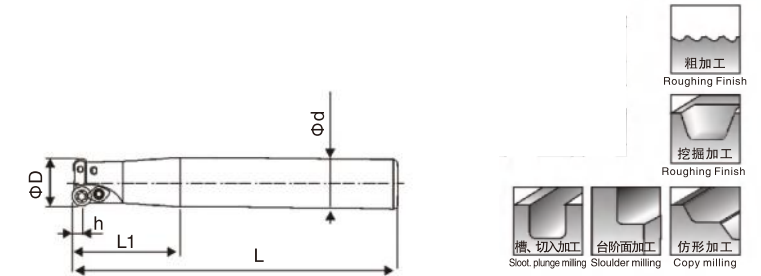

标准备库品 Stocked Letms	型号 Cat.No	尺寸 Size						适用刀片 Applicable inserts	齿数 Teeth	扳手 Wrench	螺钉 Screw	压板 Pressure plate
		ϕD	ϕd	L	L1	L2	h					
EMRW-6R-32-160-C25-2T		32	25	160	50	-	6	RPMW/T1204 MO	2	T15	M4X10	WD-204
EMRW-6R-32-200-C25-2T		32	25	200	50	-	6	RPMW/T1204 MO	2	T15	M4X10	WD-204
EMRW-6R-32-250-C25-2T		32	25	250	60	-	6	RPMW/T1204 MO	2	T15	M4X10	WD-204
EMRW-6R-35-160-C32-3T		35	32	160	50	-	6	RPMW/T1204 MO	3	T15	M4X10	WD-204
EMRW-6R-35-200-C32-3T		35	32	200	50	-	6	RPMW/T1204 MO	3	T15	M4X10	WD-204
EMRW-6R-35-250-C32-3T		35	32	250	60	-	6	RPMW/T1204 MO	3	T15	M4X10	WD-204
EMRW-6R-35-300-C32-3T		35	32	300	60	-	6	RPMW/T1204 MO	3	T15	M4X10	WD-204
EMRW-6R-35-350-C32-3T		35	32	350	60	-	6	RPMW/T1204 MO	3	T15	M4X10	WD-204
EMRW-6R-40-200-C32-3T		40	32	200	50	-	6	RPMW/T1204 MO	3	T15	M4X10	WD-204
EMRW-6R-40-250-C32-3T		40	32	250	60	-	6	RPMW/T1204 MO	3	T15	M4X10	WD-204
EMRW-6R-40-300-C32-3T		40	32	300	60	-	6	RPMW/T1204 MO	3	T15	M4X10	WD-204
EMRW-6R-40-350-C32-3T		40	32	350	60	-	6	RPMW/T1204 MO	3	T15	M4X10	WD-204

备注：配套刀片建议参照三菱牌刀片。 Note: Matching insert we suggest Mitsubishi brand

TRS 圆鼻立铣刀

TRS round dowel end mill

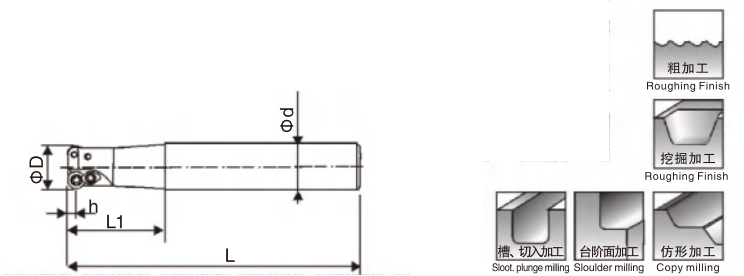

标准备库品 Stocked Letms	型号 Cat.No	尺寸 Size						适用刀片 Applicable inserts	齿数 Teeth	扳手 Wrench	螺钉 Screw	压板 Pressure plate
		ϕD	ϕd	L	L1	L2	h					
TRS-4R-12-130-C12-1T		12	12	130	40	-	4	RDMT0802MO	1	T08	M3X7	
TRS-4R-16-160-C16-2T		16	16	160	40	-	4	RDMT0802MO	2	T08	M3X7	WD-202
TRS-4R-20-160-C20-2T		20	20	160	50	-	4	RDMT0802MO	2	T08	M3X7	WD-202
TRS-4R-20-200-C20-2T		20	20	200	50	-	4	RDMT0802MO	2	T08	M3X7	WD-202
TRS-5R												
TRS-5R-25-160-C25-2T		25	25	160	50	-	5	RDMT10T3M0	2	T15	M4X10	WD-204
TRS-5R-25-200-C25-2T		25	25	200	75	-	5	RDMT10T3M0	2	T15	M4X10	WD-204
TRS-5R-30-160-C25-2T		30	25	160	40	-	5	RDMT10T3M0	2	T15	M4X10	WD-204
TRS-5R-30-200-C25-2T		30	25	200	50	-	5	RDMT10T3M0	2	T15	M4X10	WD-204
TRS-5R-30-250-C25-2T		30	25	300	60	-	5	RDMT10T3M0	2	T15	M4X10	WD-204
TRS-5R-35-160-C32-3T		35	32	160	50	-	5	RDMT10T3M0	3	T15	M4X10	WD-204
TRS-5R-35-200-C32-3T		35	32	200	50	-	5	RDMT10T3M0	3	T15	M4X10	WD-204
TRS-5R-35-250-C32-3T		35	32	250	60	-	5	RDMT10T3M0	3	T15	M4X10	WD-204

备注：配套刀片建议参照日立牌刀片。 Note: Matching insert we suggest Hitachi brand

了解具体库存情况请致电厂家 详情请登陆网站www.hnsant.com

模具铣削刀具 | MOLD MILLING TOOLS



可转位铣削刀具 Indexable milling tools

BAP直角台肩壳铣刀

BAP right angle shoulder face mill

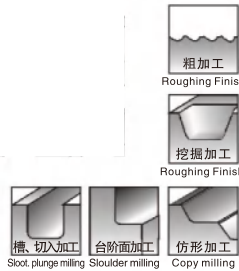
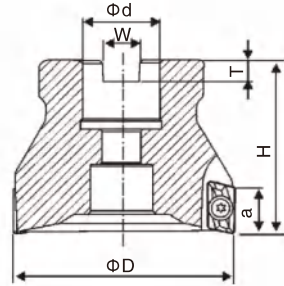

标准备库品 Stocked Letms	型号 Cat.No	尺寸 Size						适用刀片 Applicable inserts	齿数 Teeth	扳手 Wrench	螺钉 Screw	压板 Pressure plate
		ΦD	Φd	H	W	T	a					
BAP400R-50-22-4T		50	22	50	10.4	6.3	14	APMT1604PDER	4	T15	M4X10	-
BAP400R-63-22-4T		63	22	50	10.4	6.3	14	APMT1604PDER	4	T15	M4X10	-
BAP400R-63-22-5T		63	22	50	10.4	6.3	14	APMT1604PDER	5	T15	M4X10	-
BAP400R-80-27-6T		80	27	50	12.4	7	14	APMT1604PDER	6	T15	M4X10	-
BAP400R-100-32-6T		100	32	50	14.4	8	14	APMT1604PDER	6	T15	M4X10	-
BAP400R-125-40-6T		125	40	63	16.4	9	14	APMT1604PDER	6	T15	M4X10	-

备注：配套刀片建议参照三菱、株洲钻石牌刀片。Note: Matching insert we suggest Mitsubishi, Zccct brand

EMR圆鼻壳形铣刀

EMR round dowel face mill

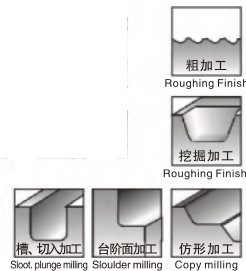
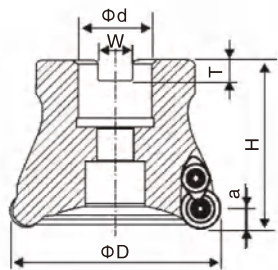

标准备库品 Stocked Letms	型号 Cat.No	尺寸 Size						适用刀片 Applicable inserts	齿数 Teeth	扳手 Wrench	螺钉 Screw	压板 Pressure plate
		ΦD	Φd	H	W	T	a					
EMR-5R-50-22-4T		50	22	50	10.4	6.3	5	RPMW1003M0	4	T15	M4X10	WD-204
EMR-5R-63-22-4T		63	22	50	10.4	6.3	5	RPMW1003M0	4	T15	M4X10	WD-204
EMR-5R-63-22-5T		63	22	50	10.4	6.3	5	RPMW1003M0	5	T15	M4X10	WD-204
EMR-5R-80-27-6T		80	27	50	12.4	7	5	RPMW1003M0	6	T15	M4X10	WD-204
EMR-5R-100-32-6T		100	32	50	14.4	7	5	RPMW1003M0	6	T15	M4X10	WD-204

备注：配套刀片建议参照ISO标准刀片。Note: Matching insert we suggest ISO standard brand

了解具体库存情况请致电厂家 详情请登陆网站www.hnsant.com



模具铣削刀具 | MOLD MILLING TOOLS

Indexable milling tools 可转位铣削刀具

EMRW圆鼻壳形铣刀

EMRW round dowel face mill

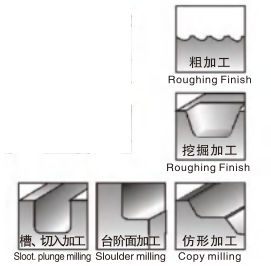
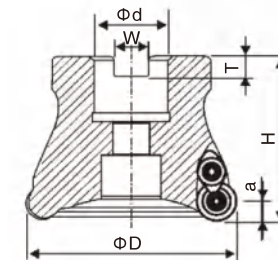

标准备库品 Stocked Letms	型号 Cat.No	尺寸 Size						适用刀片 Applicable inserts	齿数 Teeth	扳手 Wrench	螺钉 Screw	压板 Pressure plate
		ΦD	Φd	H	W	T	a					
EMRW-6R-50-22-4T		50	22	50	10.4	6.3	6	RPMW/T1204M0	4	T15	M4X10	WD-204
EMRW-6R-63-22-4T		63	22	50	10.4	6.3	6	RPMW/T1204M0	4	T15	M4X10	WD-204
EMRW-6R-63-22-5T		63	22	50	10.4	6.3	6	RPMW/T1204M0	5	T15	M4X10	WD-204
EMRW-6R-80-27-6T		80	27	50	12.4	7	6	RPMW/T1204M0	6	T15	M4X10	WD-204
EMRW-6R-100-32-6T		100	32	50	14.4	7	6	RPMW/T1204M0	6	T15	M4X10	WD-204

备注：配套刀片建议参照三菱牌刀片。Note: Matching insert we suggest Mitsubishi brand

TRS圆鼻立铣刀

TRS round dowel end mill

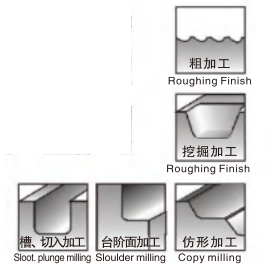
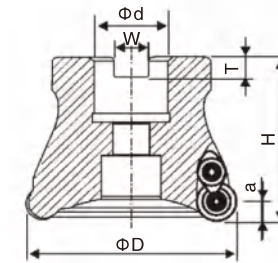

标准备库品 Stocked Letms	型号 Cat.No	尺寸 Size						适用刀片 Applicable inserts	齿数 Teeth	扳手 Wrench	螺钉 Screw	压板 Pressure plate
		ΦD	Φd	H	W	T	a					
TRS-5R-50-22-4T		50	22	50	10.4	6.3	5	RDMT10T3M0	4	T15	M4X10	WD-204
TRS-5R-63-22-4T		63	22	50	10.4	6.3	5	RDMT10T3M0	4	T15	M4X10	WD-204
TRS-6R-50-22-4T		50	22	50	10.4	6.3	6	RDMT1204M0	4	T15	M4X10	WD-204
TRS-6R-63-22-4T		63	22	50	10.4	6.3	6	RDMT1204M0	4	T15	M4X10	WD-204
TRS-6R-63-22-5T		63	22	50	10.4	6.3	6	RDMT1204M0	5	T15	M4X10	WD-204
TRS-6R-80-27-6T		80	27	50	12.4	7	6	RDMT1204M0	6	T15	M4X10	WD-204

备注：配套刀片建议参照日立牌刀片。Matching insert we suggest Hitachi brand

KM-45°壳形铣刀

KM-45° face mill

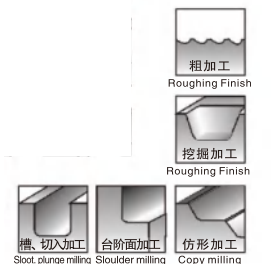
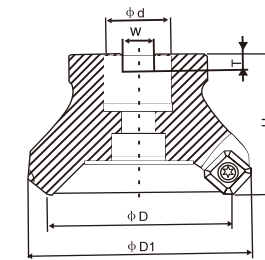

标准备库品 Stocked Letms	型号 Cat.No	尺寸 Size						适用刀片 Applicable inserts	齿数 Teeth	扳手 Wrench	螺钉 Screw	压板 Pressure plate
		ΦD	Φd	H	W	T	$\Phi D1$					
KM12-50-22-4T		50	22	50	10.4	6.3	64	SEKT1204□□	4	T20	M5X11	
KM12-63-22-4T		63	22	50	10.4	6.3	77	SEKT1204□□	4	T20	M5X11	
KM12-80-27-5T		80	27	50	12.4	7	94	SEKT1204□□	5	T20	M5X11	
KM12-100-32-5T		100	32	50	14.4	8	114	SEKT1204□□	5	T20	M5X11	

备注：配套刀片建议参照三菱、株洲钻石牌刀片。Note: Matching insert we suggest Mitsubishi, Zccct brand.

了解具体库存情况请致电厂家 详情请登陆网站www.hnsant.com