

目录 (一)

CONTENTS

车削刀具 页码提示

产品预览
PROUDUT PREVIEW P01~P06

外圆端面车刀型号说明
INDEXABLE EXTERNAL TURNING TOOL CODE KEY P07~P08

M型外圆车刀
M TYPE EXTERNAL TURNING TOOL HOLDERS P09~P20

P型外圆车刀
P TYPE EXTERNAL TURNING TOOL HOLDERS P21~P28

S型外圆车刀
S TYPE EXTERNAL TURNING TOOL HOLDERS P29~P40

C型外圆车刀
C TYPE EXTERNAL TURNING TOOL HOLDERS P41~P44

D型外圆车刀
D TYPE EXTERNAL TURNING TOOL HOLDERS P45~P54

W型外圆车刀
W TYPE EXTERNAL TURNING TOOL HOLDERS P55~P56

内孔车刀型号说明
INTERNAL TURNING TOOL HOLDER CODE KEY P57

M型内孔车刀
M TYPE INTERNAL TURNING TOOL HOLDERS P58~P65

P型内孔车刀
P TYPE INTERNAL TURNING TOOL HOLDERS P66~P68

D型内孔车刀
D TYPE INTERNAL TURNING TOOL HOLDERS P69

S型内孔车刀
S TYPE INTERNAL TURNING TOOL HOLDERS P70~P79

S型钨钢抗震刀杆
S TYPE CARBIDE BORING BARS P80~P82

螺纹车刀型号说明
THREADING TOOL HOLDERS CODE KEY P83

外螺纹车刀
EXTERNAL THREADING TOOLS P84

内螺纹车刀
INTERNAL THREADING TOOLS P85

切断切槽刀型号说明
PARTING AND GROOVING HOLDERS CODE KEY P86

切断切槽车刀
PARTING CROOVING TURNING TOOLS P87~P103

目录 (二)

CONTENTS

可转位铣削刀具 页码提示

可转位铣削刀具一览表
INDEXABLE MILLING TOOLS OVERVIEW P104~P108

可转位铣削刀具命名规则
INDEXABLE MILLING TOOLS CODE KEY P109~P110

可转位铣削刀片命名规则
INDEXABLE MILLING INSERTS CODE KEY P111~P112

可转位铣削刀具系列
INDEXABLE MILLING TOOLS P113~P236

面铣刀系列
FACE MILLING TOOLS P113~P164

方肩台阶铣刀系列
S SQUARE-SHOULDER MILLING TOOLS P165~P186

仿形铣刀系列
PROFILE MILLING TOOLS P187~P193

三面刃铣刀系列
SIDE AND FACE MILLING TOOLS P194~P214

倒角铣刀系列
CHAMFER MILLING TOOLS P215~P217

特殊铣刀(大进给)系列
HIGH FEED MILLING CUTTER P218~P229

螺旋立铣刀系列
HELICAL END FACE MILLING TOOLS P230~P231

立铣刀/壳形铣刀
END MILL/FACE MILL P232~P236

目录 (三)

CONTENTS

孔加工刀具 页码提示

可转位浅孔钻系列
INDEXABLE U DRILL P237~P252

镗削刀具系列
BORING TOOLS P253~P279

目录 (四) CONTENTS

工具系统 页码提示

弹簧夹头刀柄 COLLET CHUCK ARBORS	P280~P285
接长杆 EXTENSION BAR	P286
强力铣夹头刀柄 POWER MILLING CHUCK ARBORS	P287~P288
侧固式刀柄 SIDE LOCK END MILL CHUCK	P289~P291
套式铣刀柄 SHELL END MILL ARBORS	P292~P296
有扁尾莫氏锥柄 MORSE TAPER WITH TANG	P297~P298
无扁尾莫氏锥柄 MORSE TAPER WITHOUT TANG	P299~P300
三面刃铣刀柄 TOOL SHANK FOR SIDE AND FACE MILLING CUTTER	P301~P302
工具系统附件 TOOL SYSTEM ACCESSORIES	P303~P309
工具系统技术信息 TOOL SYSTEM TECHNICAL INFORMATION	P310~P316



M类 复合压紧式 Top and hole clamping

结构特点:

Design features

- 压板和偏心销双重紧固式。Top and hole clamping dualclamp.
- 紧固力强,适用于中~重切削用。Great fastener force.
- 刀片多转位角,经济耐用。Indexable inserts, economy and durability.



P类 杠杆压紧式 Hole clamping

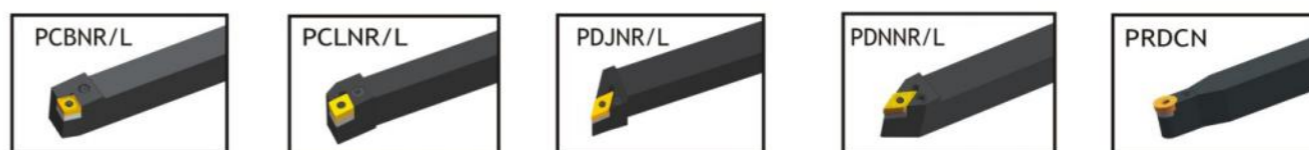

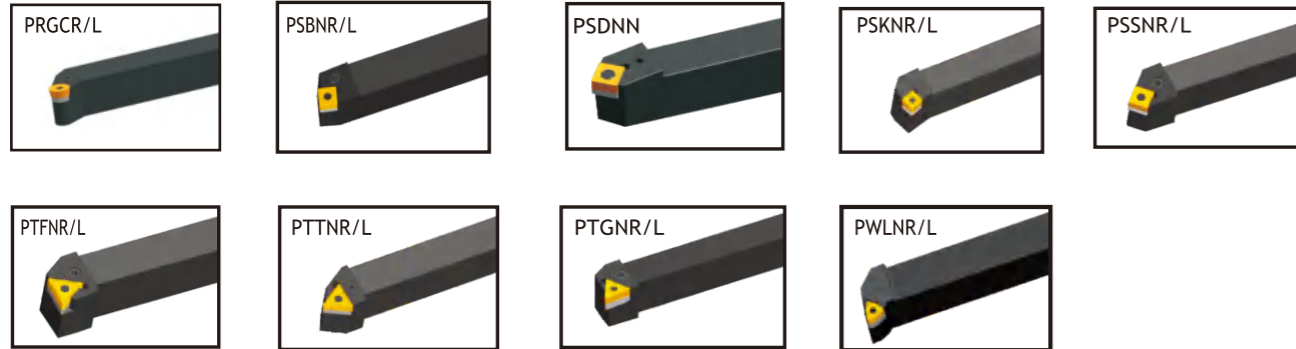

■ S类 螺钉压紧式 Screw on

结构特点:
Design features

- 采用螺钉直接压紧。Using screw for direct clamping.
- 结构简单,配件少。Simple structure, fewer parts.
- 精~中加工用。Apply For Micro And Medium Processes.

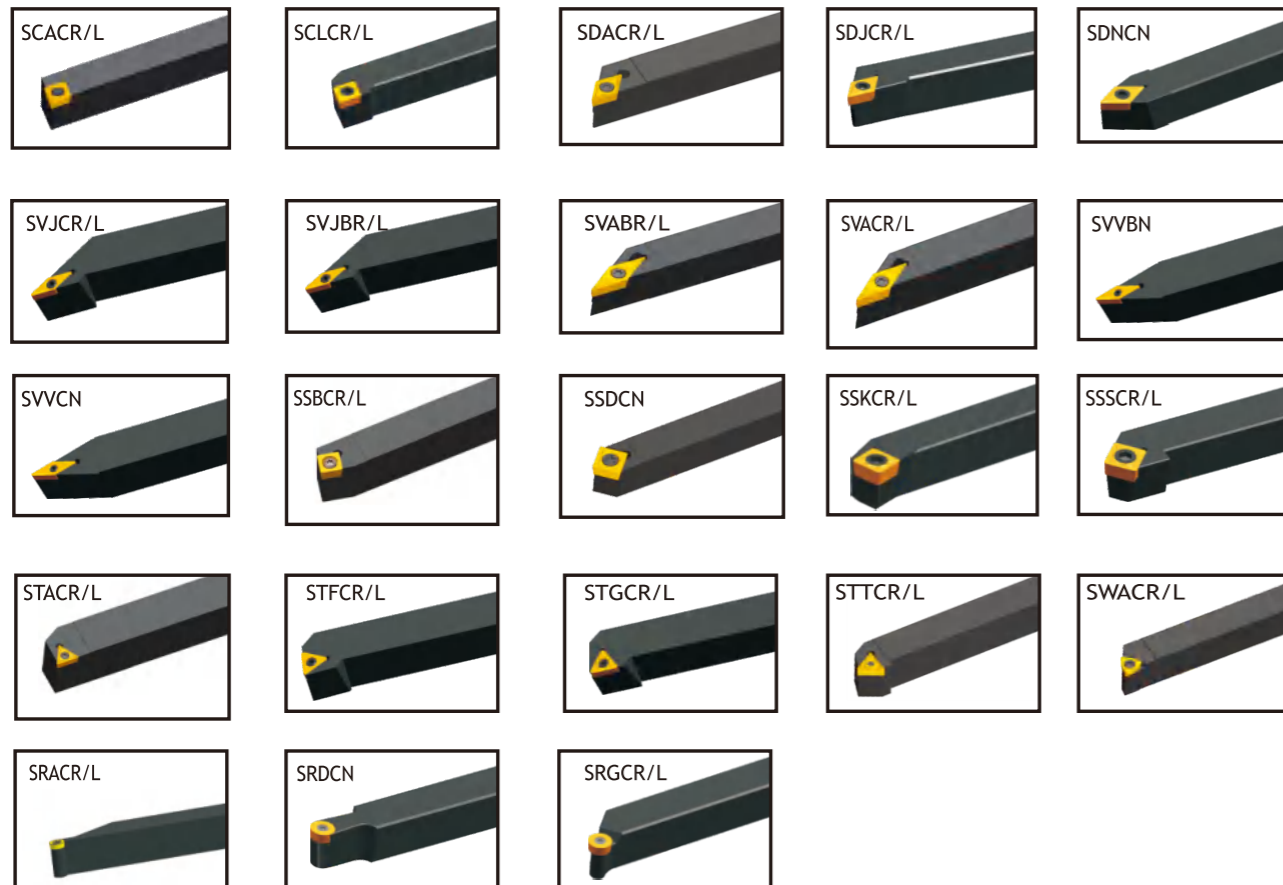

■ C类 压板压紧式 Top clamping

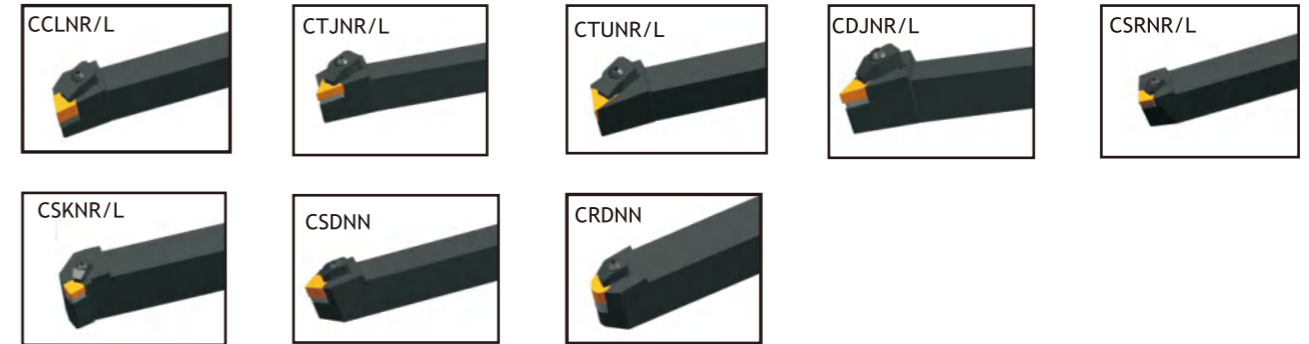

■ W型压紧式 Wedge clamping



■ D型压紧式 Wedge clamping

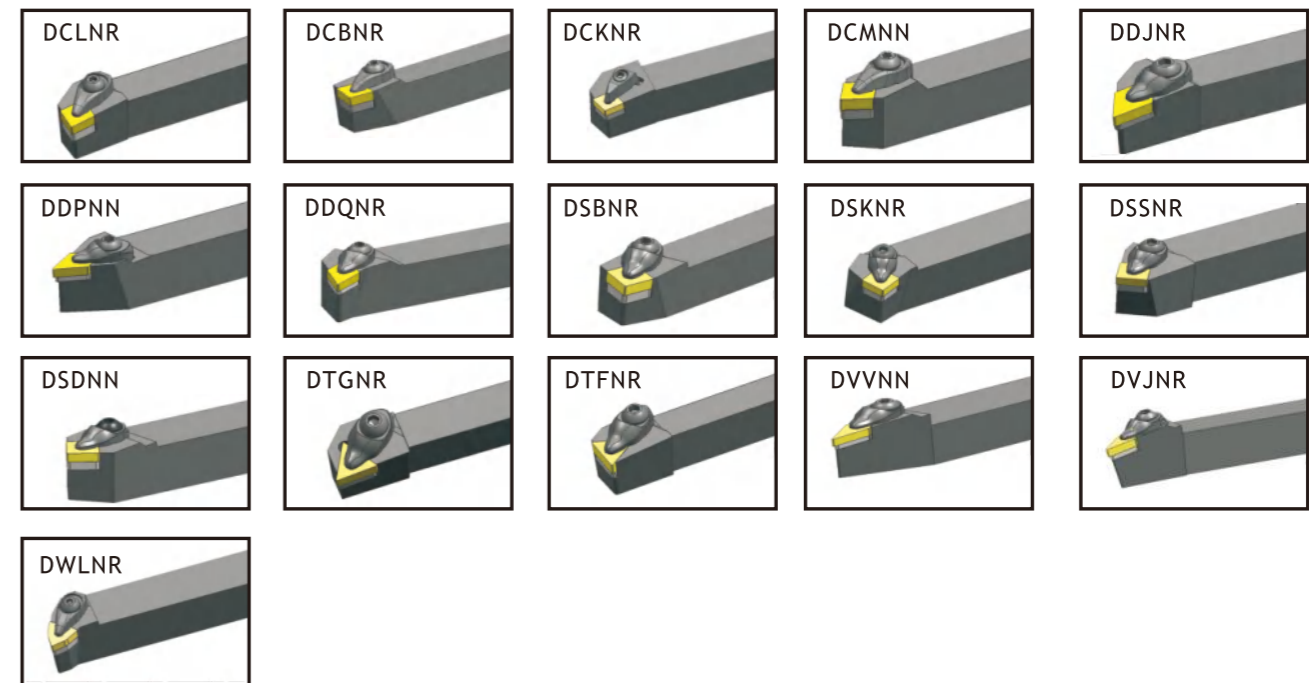

内孔车刀 Internal toolholders

M类 复合压紧式 Top and hole clamping

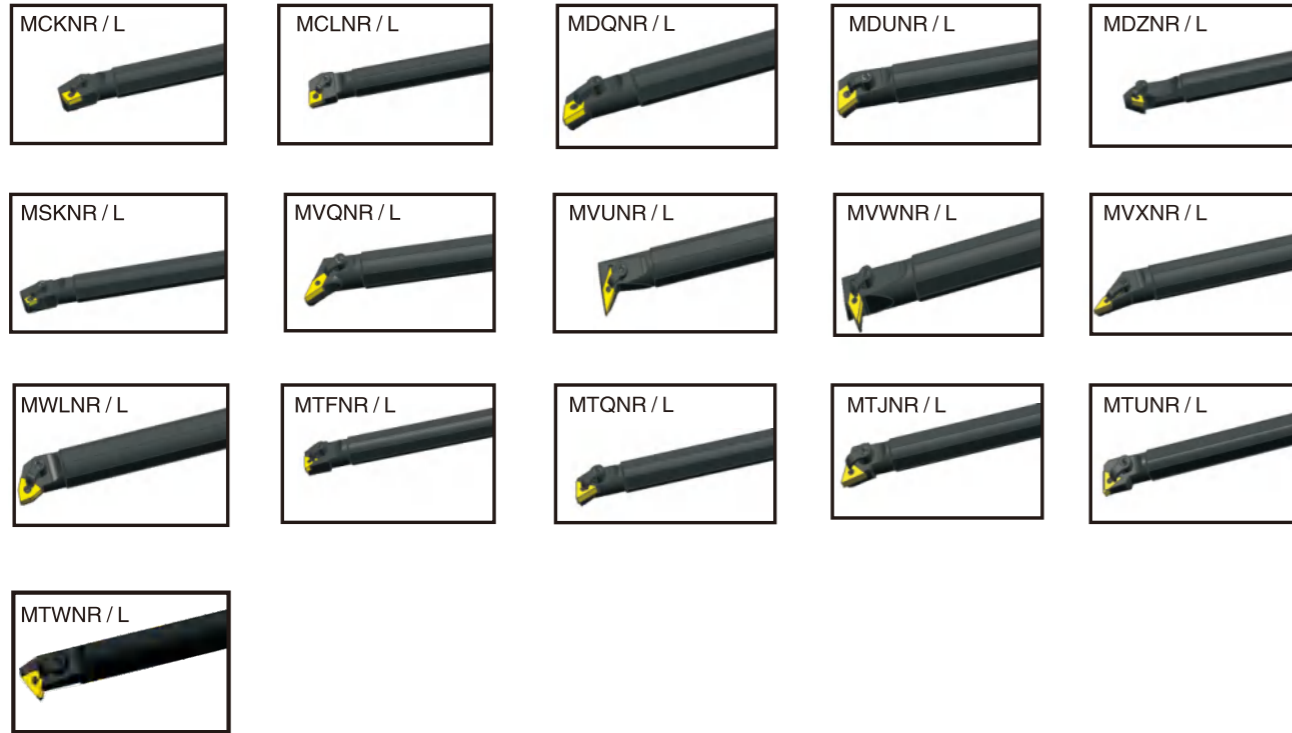

P类 杠杆压紧式 Hole clamping



S类 螺钉压紧式 Screw on



S类 钨钢内孔刀杆 Tungsten steel Internal Turning tools

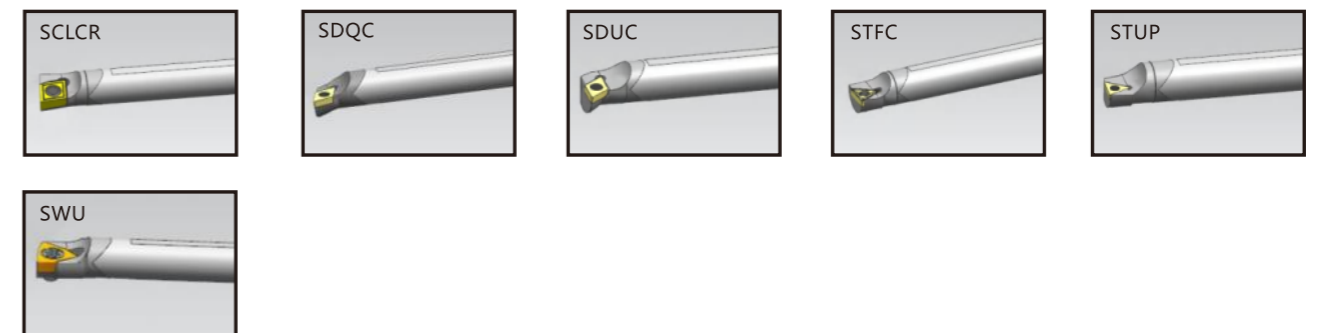

车削刀具 | TURNING TOOLS



外圆车刀的型号表示规则 ISO-indexable Insert External Turning Tools Code Key

螺纹车削刀具 Threading tools

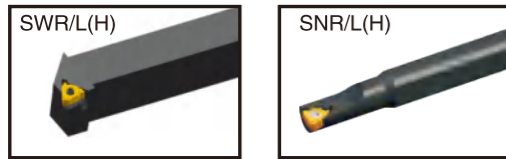

切断切槽刀具 Parting, grooving tools

外圆、端面切断切槽刀具 External Parting, Surface Grooving Tools

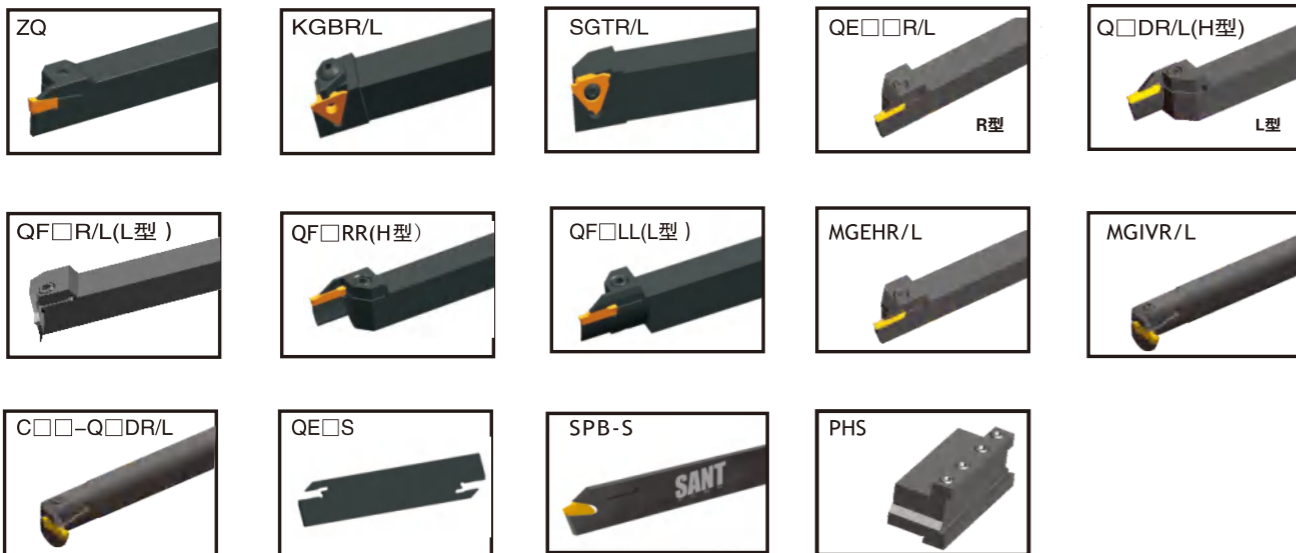

车削刀具 | TURNING TOOLS

ISO-indexable Insert External Turning Tools Code Key 外圆车刀的型号表示规则

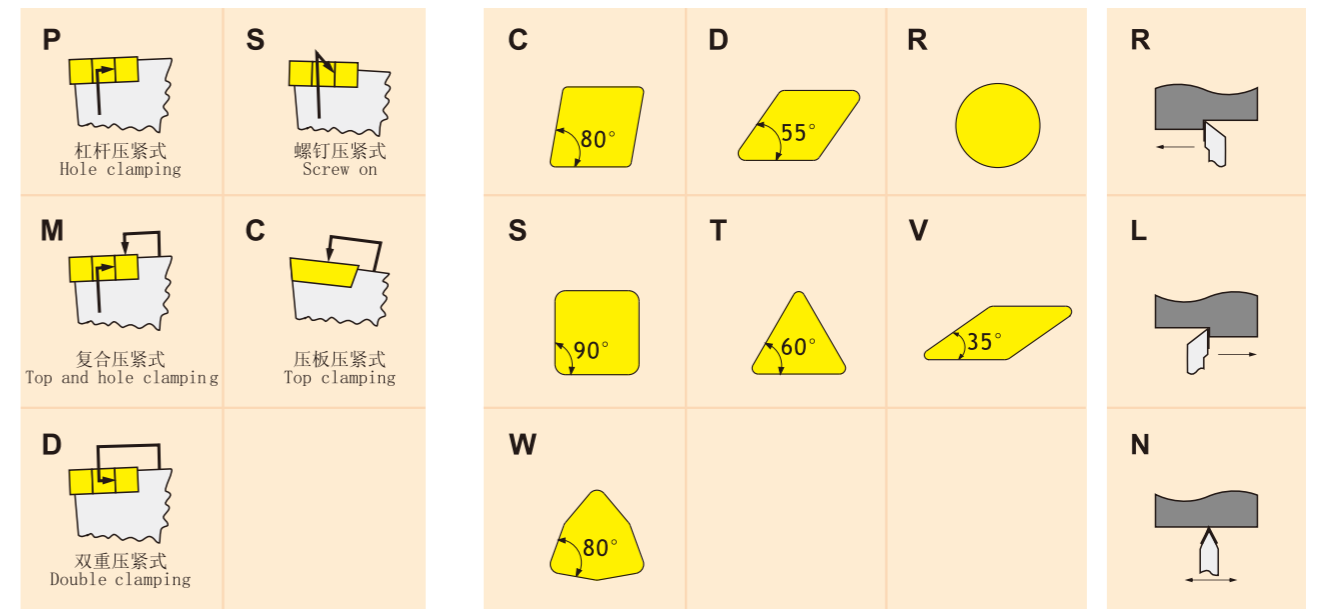

1. 压紧方式 Clamping system
2. 刀片形状 Insert shape
3. 刀具形式与主偏角 Holder style and leading angle
4. 刀片后角 Insert clearance angle
5. 切削方向 Cutting direction

范例 Example

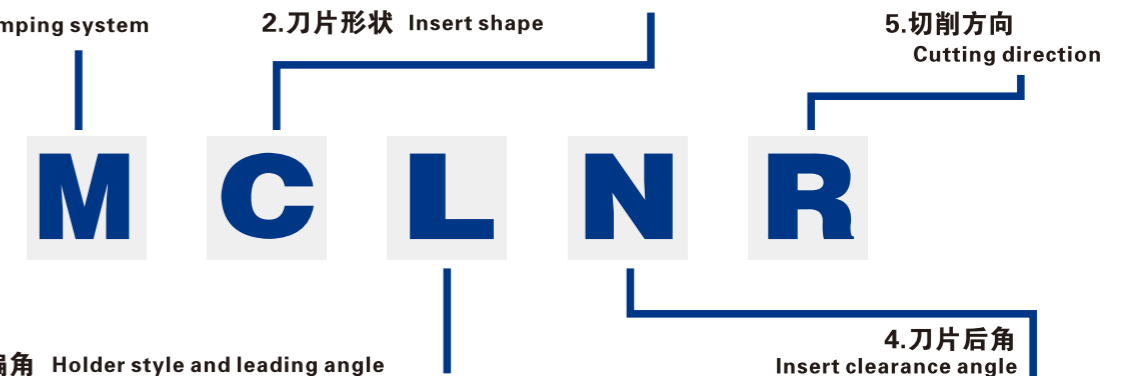

A	B	C	D	E	F	N
						0°
H	G	J	K	L	M	B
						5°
N	O	P	Q	R	S	C
						7°
T	U	V	W	X		P
						11°
						D
						15°
						E
						20°

车削刀具 | TURNING TOOLS



外圆车刀 External turning toolholders

记号 Symbol	高度/mm Height/mm
12	12
16	16
20	20
25	25
32	32
40	40
50	50

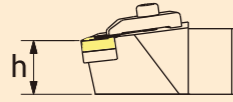

只标注到整数 例:h=8mm,标为08
Integers to be preceded by 0
eg:h=8 indicated by 08

记号 Symbol	高度/mm Height/mm
12	12
16	16
20	20
25	25
32	32
40	40
50	50

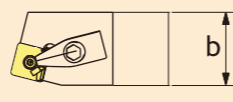

例:b=8mm,标为08
Integers to be preceded by 0
eg:b=8 indicated by 08

6.刀尖高度 Tools-tip height

7.刀体宽度 Shank width

25 25 M 12

8.刀具长度
Tool length

代号 Code	长度 Length	代号 Code	长度 Length
D	60	Q	180
E	70	R	200
F	80	S	250
G	90	T	300
H	100	U	350
K	125	V	400
M	150	W	450
P	170		

9.切削刃长 Cutting edge length

刀片形状 Insert Shape	切削刃长度 Cutting Edge Length						
	C	D	R	S	T	V	W
内接圆 Inscribed Circle							
5.556					09		
6.350	06	07			11		
9.525	09	11	09	09	16	16	
12.700	12	15	12	12	22	22	
15.875	16	19	15	15	27		
19.050	19		19	19	33		
25.400	25		25	25	44		

了解具体库存情况请致电厂家 详情请登陆网站www.hnsant.com



车削刀具 | TURNING TOOLS

External turning toolholders 外圆车刀

MCLNR/L

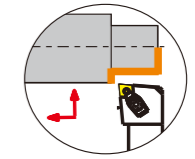
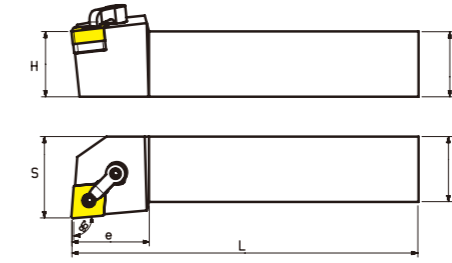

Type 型号	Dimension(mm) 基本尺寸							Applicable Inserts 使用的刀片	Clamping screw 双头螺钉	Shim 刀垫	Wrench 扳手	Clamp 压板	Clamping stud 销钉	
	Stock 库存		a	b	L	h	s							e
	R	L												
MCLNR/L 1616H12			16	16	100	16	21	30	CN □ 1204□□	WS061025	MC1204	S3	MCL1814	MSP617
2020K12			20	20	125	20	25	28						
2525M12			25	25	150	25	32	32						
3225P12			32	25	170	32	32	32						
3232P12			32	32	170	32	39	32						
2525M16			25	25	150	25	32	38	CN □ 1606□□	WS061030	MC1604	S3	MCL2114	MSP821
3225P16			32	25	170	32	33	38						
3232P16			32	32	170	32	40	38						
3232P19			32	32	170	32	40	43	CN □ 1906□□	WS081030	MC1904	S4	MCL2217	MSP1021
4040R19			40	40	200	40	50	43						

MCBNR/L

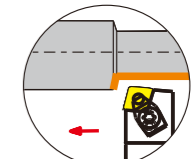
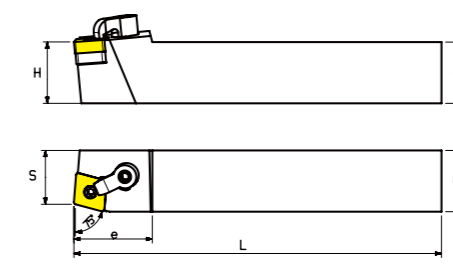

Type 型号	Dimension(mm) 基本尺寸							Applicable Inserts 使用的刀片	Clamping screw 双头螺钉	Shim 刀垫	Wrench 扳手	Clamp 压板	Clamping stud 销钉	
	Stock 库存		a	b	L	h	s							e
	R	L												
MCBNR/L 2020K12			20	20	125	20	17	32	CN □ 1204□□	WS061025	MC1204	S3	MCL1814	MSP617
2525M12			25	25	150	25	22	32						
3225P12			32	25	170	32	22	32						
2525M16			25	25	150	25	22	36	CN □ 1606□□	WS061030	MC1604	S3	MCL2114	MSP821
3225P16			32	25	170	32	22	35						
3232P16			32	32	170	32	27	35						
3232P19			32	32	170	32	27	40	CN □ 1906□□	WS081030	MC1904	S4	MCL2217	MSP1021
4040R19			40	40	200	40	35	40						

了解具体库存情况请致电厂家 详情请登陆网站www.hnsant.com

车削刀具 | TURNING TOOLS



外圆车刀 External turning toolholders

MCKNR/L

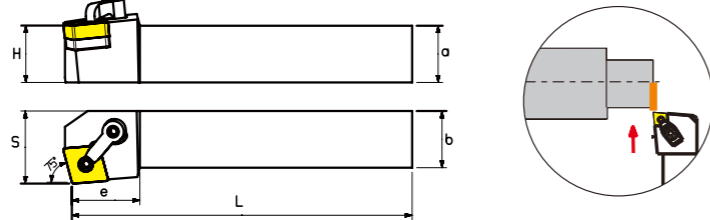

Type 型号	Dimension(mm) 基本尺寸						适用 刀片 配件	Clamping screw 双头螺钉	Shim 刀垫	Wrench 扳手	Clamp 压板	Clamping stud 销钉	
	a	b	L	h	s	e							
MCKNR/L	2020K12	20	20	125	20	25	28	CN□ 1204□	WS061025	MC1204	S3	MCL1814	MSP617
	2525M12	25	25	150	25	32	28		WS061030				
	3225P12	32	25	170	32	32	28						
	2525M16	25	25	150	25	32	30	CN□ 1606□	WS061030	MC1604	S3	MCL2114	MSP821
	3225P16	32	25	170	32	32	30						
	3232P16	32	32	170	32	38	30						
3232P19	32	32	170	32	40	36	CN□ 1906□	WS081030	MC1904	S4	MCL2217	MSP1021	
4040R19	40	40	200	40	48	36							

MDJNR/L

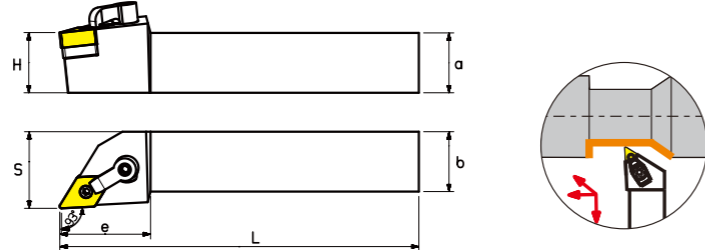

Type 型号	Dimension(mm) 基本尺寸						适用 刀片 配件	Clamping screw 双头螺钉	Shim 刀垫	Wrench 扳手	Clamp 压板	Clamping stud 销钉	
	a	b	L	h	s	e							
MDJNR/L	1616H11	16	16	100	16	20	30	DN□ 1104□	WS061025	MD1103	S2	MCL1814	MSP513
	2020K11	20	20	125	20	25	32		WS061030				
	2525M11	25	25	150	25	32	32						
	3225P11	32	25	170	32	32	32	DN□ 1504□ DN□ 1506□	WS061025	MD1504	S3	MCL2114	04:MSP617 06:MSP619
	2020K1504/06	20	20	125	20	25	36						
	2525M1504/06	25	25	150	25	32	38						
	3225P1504/06	32	25	170	32	32	38		WS061030	MD1504	S3	MCL2114	04:MSP617 06:MSP619
	3232P1504/06	32	32	170	32	40	38						
	4040R15	40	40	200	40	48	40	DN□ 1506□					

了解具体库存情况请致电厂家 详情请登陆网站www.hnsant.com



车削刀具 | TURNING TOOLS

External turning toolholders 外圆车刀

MDPNN

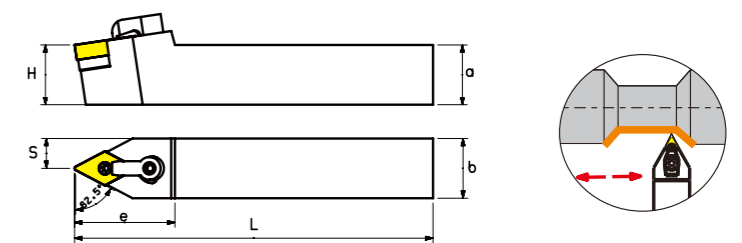

Type 型号	Dimension(mm) 基本尺寸						适用 刀片 配件	Clamping screw 双头螺钉	Shim 刀垫	Wrench 扳手	Clamp 压板	Clamping stud 销钉	
	a	b	L	h	s	e							
MDPNN	1616H11	16	16	100	16	8	35	DN□ 1104□	WS061025	MD 1103	S2 S3	MCL1814	MSP513
	2020K11	20	20	125	20	10	34		WS061030				
	2525M11	25	25	150	25	12.5	36						
	3225P11	32	25	170	32	12.5	35	DN□ 1504□ DN□ 1506□	WS061025	MD1504	S3	MCL2114	04:MSP617 06:MSP619
	2020K1504/06	20	20	125	20	10	42						
	2525M1504/06	25	25	150	25	12.5	42						
	3225P1504/06	32	25	170	32	12.5	42		WS061030	MD1504	S3	MCL2114	04:MSP617 06:MSP619
	3232P1504/06	32	32	170	32	16	42						

MDQNR/L

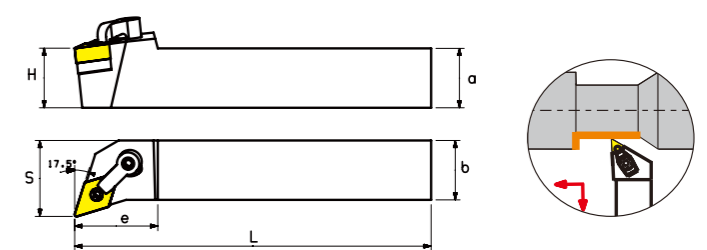

Type 型号	Dimension(mm) 基本尺寸						适用 刀片 配件	Clamping screw 双头螺钉	Shim 刀垫	Wrench 扳手	Clamp 压板	Clamping stud 销钉	
	a	b	L	h	s	e							
MDQNR/L	1616H11	16	16	100	16	21	30	DN□ 1104□	WS061025	MD 1103	S2 S3	MCL1814	MSP513
	2020K11	20	20	125	20	25	32		WS061030				
	2525M11	25	25	150	25	30	30						
	3225P11	32	25	170	32	30	30	DN□ 1504□ DN□ 1506□	WS061025	MD1504	S3	MCL2114	04:MSP617 06:MSP619
	2020K1504/06	20	20	125	20	27	36						
	2525M1504/06	25	25	150	25	32	35						
	3225P1504/06	32	25	170	32	32	35		WS061030	MD1504	S3	MCL2114	04:MSP617 06:MSP619
	3232P1504/06	32	32	170	32	40	35						

了解具体库存情况请致电厂家 详情请登陆网站www.hnsant.com

车削刀具 | TURNING TOOLS



外圆车刀 External turning toolholders

MSBNR/L

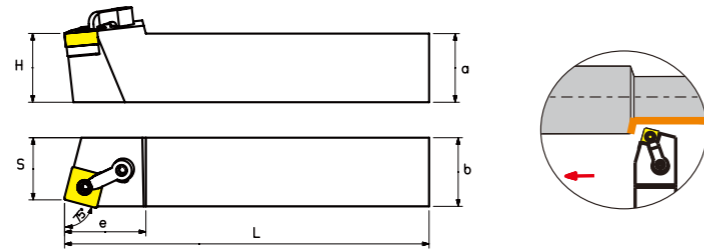

Type 型号	Dimension(mm) 基本尺寸							Applicable Inserts 使用的刀片	Clamping screw 双头螺钉	Shim 刀垫	Wrench 扳手	Clamp 压板	Clamping stud 销钉	
	Stock 库存		a	b	L	h	s							e
	R	L												
MSBNR/L	2020K12		20	20	125	20	17	34	SN□□ 1204□□	WS061025	MS1204	S3	MCL1814	MSP617
	2525M12		25	25	150	25	22	32						
	3225P12		32	25	170	32	22	32	SN□□ 1506□□	WS061030	MS1504	S3	MCL2114	MSP821
	2525M15		25	25	150	25	22	38						
	3232P15		32	32	170	32	29	38	SN□□ 2509□□	WS101035	MS2508	S4, S5	MCL3220	MSP1229
	3232P19		32	32	170	32	27	45						
	4040R19		40	40	200	40	35	45	WS101035	MS2508	S4, S5	MCL3220	MSP1229	
	4040S25		40	40	250	40	34	60						WS101035

MSRNR/L

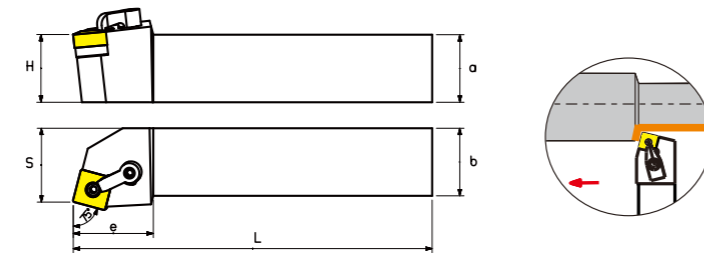

Type 型号	Dimension(mm) 基本尺寸							Applicable Inserts 使用的刀片	Clamping screw 双头螺钉	Shim 刀垫	Wrench 扳手	Clamp 压板	Clamping stud 销钉	
	Stock 库存		a	b	L	h	s							e
	R	L												
MSRNR/L	2020K12		20	20	125	20	22	32	SN□□ 1204□□	WS061025	MS1204	S3	MCL1814	MSP617
	2525M12		25	25	150	25	27	32						
	3225P12		32	25	170	32	27	32	SN□□ 1506□□	WS061030	MS1504	S3	MCL2114	MSP821
	2525M15		25	25	150	25	27	38						
	3232P15		32	32	170	32	35	38	SN□□ 2509□□	WS101035	MS2508	S4, S5	MCL3220	MSP1229
	3232P19		32	32	170	32	35	43						
	4040R19		40	40	200	40	43	43	WS101035	MS2508	S4, S5	MCL3220	MSP1229	
	4040S25		40	40	250	40	43	55						WS101035

了解具体库存情况请致电厂家 详情请登陆网站www.hnsant.com



车削刀具 | TURNING TOOLS

External turning toolholders 外圆车刀

MSKNR/L

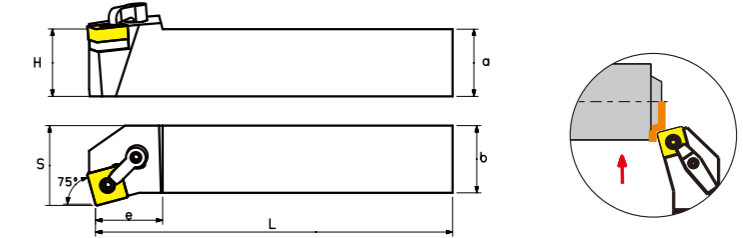

Type 型号	Dimension(mm) 基本尺寸							Applicable Inserts 使用的刀片	Clamping screw 双头螺钉	Shim 刀垫	Wrench 扳手	Clamp 压板	Clamping stud 销钉	
	Stock 库存		a	b	L	h	s							e
	R	L												
MSKNR/L	2020K12		20	20	125	20	25	28	SN□□ 1204□□	WS061025	MS1204	S3	MCL1814	MSP617
	2525M12		25	25	150	25	32	27						
	3225P12		32	25	170	32	32	27	SN□□ 1506□□	WS061030	MS1504	S3	MCL2114	MSP821
	2525M15		25	25	150	25	32	32						
	3232P15		32	32	170	32	38	32	SN□□ 2509□□	WS101035	MS2508	S4, S5	MCL3220	MSP1229
	3232P19		32	32	170	32	38	36						
	4040R19		40	40	200	40	50	40	WS101035	MS2508	S4, S5	MCL3220	MSP1229	
	4040S25		40	40	250	40	50	45						WS101035

MSDNN

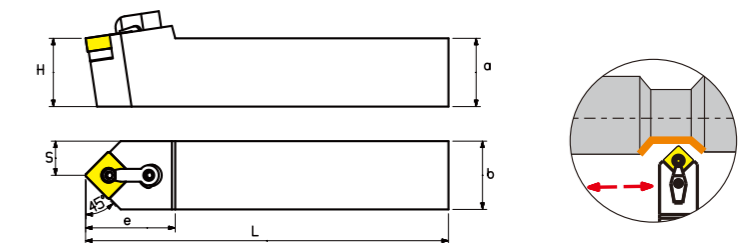

Type 型号	Dimension(mm) 基本尺寸							Applicable Inserts 使用的刀片	Clamping screw 双头螺钉	Shim 刀垫	Wrench 扳手	Clamp 压板	Clamping stud 销钉	
	Stock 库存		a	b	L	h	s							e
	R	L												
MSDNN	2020K12		20	20	125	20	10	34	SN□□ 1204□□	WS061025	MS1204	S3	MCL1814	MSP617
	2525M12		25	25	150	25	12.5	34						
	3225P12		32	25	170	32	12.5	34	SN□□ 1506□□	WS061030	MS1504	S3	MCL2114	MSP821
	2525M15		25	25	150	25	12.5	42						
	3232P15		32	32	170	32	16	42	SN□□ 2509□□	WS101035	MS2508	S4, S5	MCL3220	MSP1229
	3232P19		32	32	170	32	16	45						
	4040R19		40	40	200	40	20	50	WS101035	MS2508	S4, S5	MCL3220	MSP1229	
	4040S25		40	40	250	40	20	60						WS101035

了解具体库存情况请致电厂家 详情请登陆网站www.hnsant.com

车削刀具 | TURNING TOOLS



外圆车刀 External turning toolholders

MSSNR/L

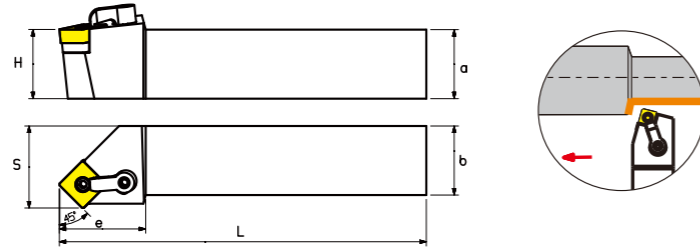

Type 型号	Dimension(mm) 基本尺寸							Applicable Inserts 使用的刀片	Clamping screw 双头螺钉	Shim 刀垫	Wrench 扳手	Clamp 压板	Clamping stud 销钉	
	Stock 库存		a	b	L	h	s							e
	R	L												
MSSNR/L	2020K12		20	20	125	20	25	36	SN□□ 1204□□	WS061025	MS1204	S3	MCL1814	MSP617
	2525M12		25	25	150	25	30	36						
	3225P12		32	25	170	32	30	33						
	3232P12		32	32	170	32	38	35	SN□□ 1506□□	WS061030	MS1504	S3	MCL2114	MSP821
	2525M15		25	25	150	25	30	40						
	3232P15		32	32	170	32	38	40	SN□□ 1906□□	WS 081030	MS 1904	S4	MCL2217	MSP1021
	3232P19		32	32	170	32	38	45						
	4040R19		40	40	200	40	46	45	SN□□ 2509□□	WS101035	MS2508	S4, S5	MCL3220	MSP1229
4040S25		40	40	250	40	50	60							

MTGNR/L

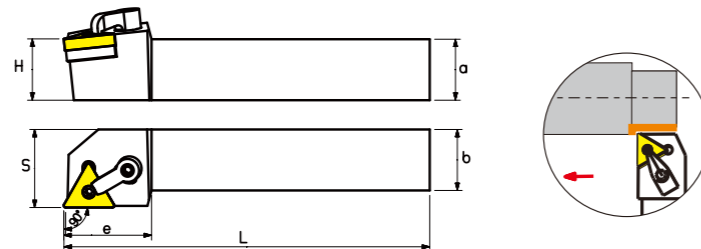

Type 型号	Dimension(mm) 基本尺寸							Applicable Inserts 使用的刀片	Clamping screw 双头螺钉	Shim 刀垫	Wrench 扳手	Clamp 压板	Clamping stud 销钉	
	Stock 库存		a	b	L	h	s							e
	R	L												
MTGNR/L	2020K16		20	20	125	20	25	32	TN□□ 1604□□	WS061025	MT1603	S2, S3	MCL1814	MSP513
	2525M16		25	25	150	25	32	30						
	3225P16		32	25	170	32	32	30						
	2525M22		25	25	150	25	32	36	TN□□ 2204□□	WS061030	MT2204	S3	MCL2114	MSP617
	3225P22		32	25	170	32	32	36						
	3232P22		32	32	170	32	38	36						

了解具体库存情况请致电厂家 详情请登陆网站www.hnsant.com



车削刀具 | TURNING TOOLS

External turning toolholders 外圆车刀

MTJNR/L

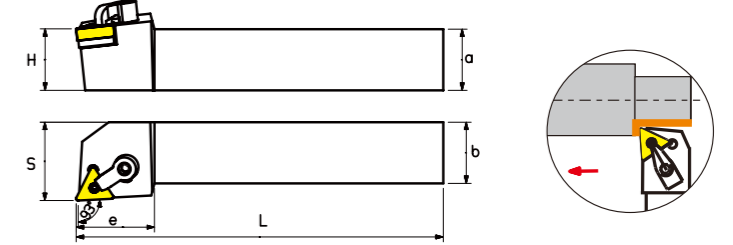

Type 型号	Dimension(mm) 基本尺寸							Applicable Inserts 使用的刀片	Clamping screw 双头螺钉	Shim 刀垫	Wrench 扳手	Clamp 压板	Clamping stud 销钉	
	Stock 库存		a	b	L	h	s							e
	R	L												
MTJNR/L	1616H16		16	16	100	16	20	28	TN□□ 1604□□	WS061025	MT1603	S2, S3	MCL1814	MSP513
	2020K16		20	20	125	20	25	32						
	2525M16		25	25	150	25	32	32						
	3225P16		32	25	170	32	32	32						
	2525M22		25	25	150	25	32	36	TN□□ 2204□□	WS061030	MT2204	S3	MCL2114	MSP617
	3225P22		32	25	170	32	32	36						
	3232P22		32	32	170	32	38	36						

MTJNR/L(B)

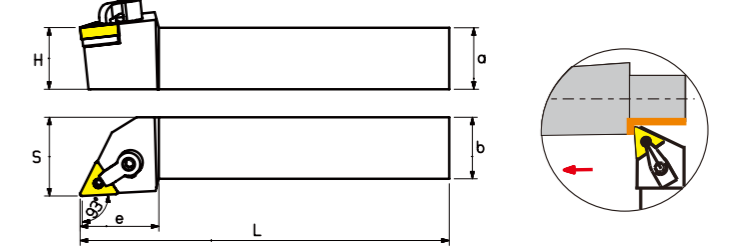

Type 型号	Dimension(mm) 基本尺寸							Applicable Inserts 使用的刀片	Clamping screw 双头螺钉	Shim 刀垫	Wrench 扳手	Clamp 压板	Clamping stud 销钉	
	Stock 库存		a	b	L	h	s							e
	R	L												
MTJNR/L	1616H16B		16	16	100	16	20	28	TN□□ 1604□□	WS061025	MT1603	S2, S3	MCL1814	MSP513
	2020K16B		20	20	125	20	25	32						
	2525M16B		25	25	150	25	32	32						
	3225P16B		32	25	170	32	32	32						
	2525M22B		25	25	150	25	32	36	TN□□ 2204□□	WS061030	MT2204	S3	MCL2114	MSP617
	3225P22B		32	25	170	32	32	36						
	3232P22B		32	32	170	32	38	36						

了解具体库存情况请致电厂家 详情请登陆网站www.hnsant.com

车削刀具 | TURNING TOOLS



外圆车刀 External turning toolholders

MTFNR/L

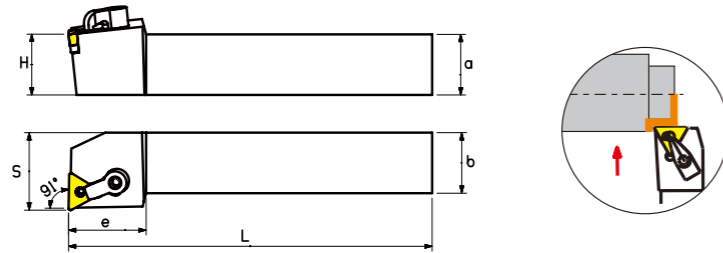

Type 型号	Dimension(mm) 基本尺寸							Applicable Inserts 使用的刀片	Clamping screw 双头螺钉	Shim 刀垫	Wrench 扳手	Clamp 压板	Clamping stud 销钉	
	Stock 库存		a	b	L	h	s							e
	R	L												
MTFNR/L	1616H16		16	16	100	16	21	28	TN□□ 1604□□	WS061025	MT1603	S2, S3	MCL1814	MSP513
	2020K16		20	20	125	20	25	30						
	2525M16		25	25	150	25	32	32						
	3225P16		32	25	170	32	32	32						
	3232P16		32	32	170	32	38	32						
2525M22		25	25	150	25	32	36	TN□□ 2204□□	WS061030	MT2204	S3	MCL2114	MSP617	
3225P22		32	25	170	32	32	36							
3232P22		32	32	170	32	38	36							

MTQNR/L

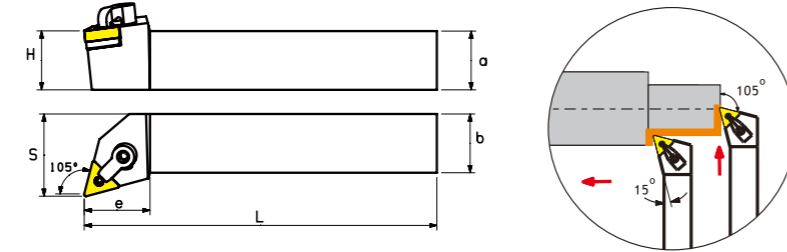

Type 型号	Dimension(mm) 基本尺寸							Applicable Inserts 使用的刀片	Clamping screw 双头螺钉	Shim 刀垫	Wrench 扳手	Clamp 压板	Clamping stud 销钉	
	Stock 库存		a	b	L	h	s							e
	R	L												
MTQNR/L	2020K16		20	20	125	20	29	25	TN□□ 1604□□	WS061025	MT1603	S2, S3	MCL1814	MSP513
	2525M16		25	25	150	25	35	28						
	3225P16		32	25	170	32	35	25						
	2525M22		25	25	150	25	38	36						
	3232P22		32	32	170	32	46	36						
									TN□□ 2204□□	WS061030	MT2204	S3	MCL2114	MSP617

了解具体库存情况请致电厂家 详情请登陆网站www.hnsant.com



车削刀具 | TURNING TOOLS

External turning toolholders 外圆车刀

MTENN

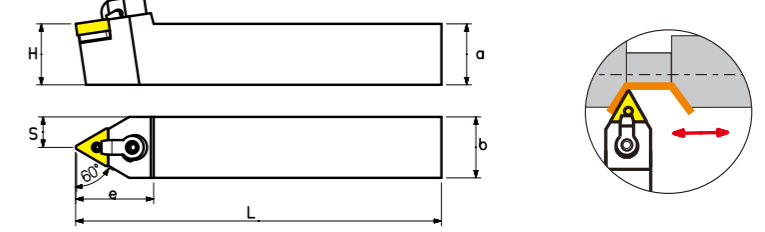

Type 型号	Dimension(mm) 基本尺寸							Applicable Inserts 使用的刀片	Clamping screw 双头螺钉	Shim 刀垫	Wrench 扳手	Clamp 压板	Clamping stud 销钉	
	Stock 库存		a	b	L	h	s							e
	R	L												
MTENN	1616H16		16	16	100	16	8	32	TN□□ 1604□□	WS061025	MT1603	S2, S3	MCL1814	MSP513
	2020K16		20	20	125	20	10	34						
	2525M16		25	25	150	25	12.5	32						
	3232P16		32	32	170	32	16	32						
									WS061030					

MVJNR/L

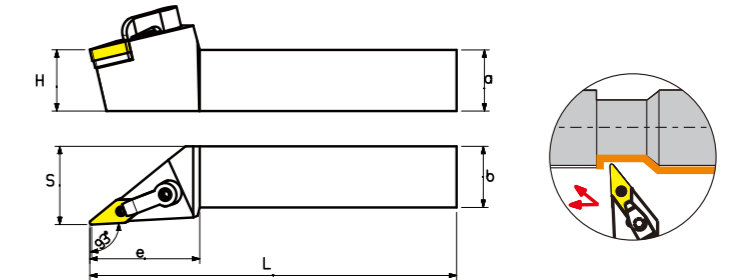

Type 型号	Dimension(mm) 基本尺寸							Applicable Inserts 使用的刀片	Clamping screw 双头螺钉	Shim 刀垫	Wrench 扳手	Clamp 压板	Clamping stud 销钉	
	Stock 库存		a	b	L	h	s							e
	R	L												
MVJNR/L	1616H16		16	16	100	16	22	43	VN□□ 1604□□ 只装株洲刀片	WS061025	MV1603	S2, S3	MCL2414	MSP513
	2020K16		20	20	125	20	26	45						
	2525M16		25	25	150	25	32	45						
	3225P16		32	25	170	32	32	45						
	3232P16		32	32	170	32	40	45						

了解具体库存情况请致电厂家 详情请登陆网站www.hnsant.com

车削刀具 | TURNING TOOLS



外圆车刀 External turning toolholders

MVVNN

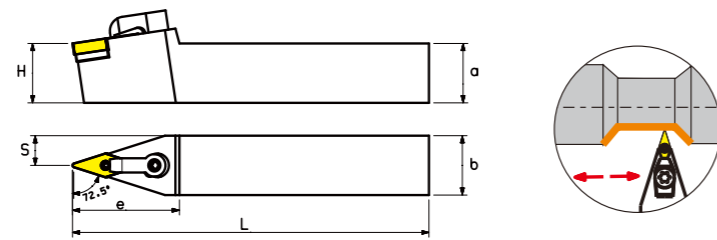

Type 型号	Dimension(mm) 基本尺寸							Applicable Inserts 使用的刀片	Clamping screw 双头螺钉	Shim 刀垫	Wrench 扳手	Clamp 压板	Clamping stud 销钉
	Stock 库存	a	b	L	h	s	e						
MVVNN 2020K16		20	20	125	20	10	45	VN□□ 1604□□ 只装株洲刀片	WS061025	MV1603	S2 S3	MCL2414	MSP513
2525M16		25	25	150	25	12.5	45						
3225P16		32	25	170	32	12.5	45						
3232P16		32	32	170	32	16	45						

MVUNR/L

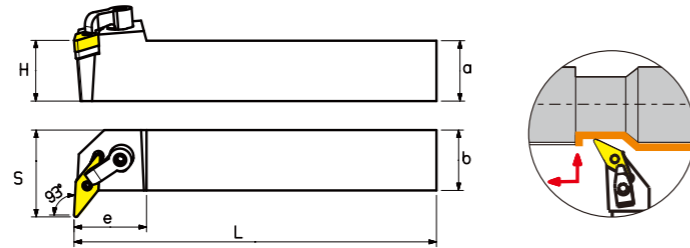

Type 型号	Dimension(mm) 基本尺寸							Applicable Inserts 使用的刀片	Clamping screw 双头螺钉	Shim 刀垫	Wrench 扳手	Clamp 压板	Clamping stud 销钉
	Stock 库存	a	b	L	h	s	e						
MVUNR/L 1616H16		16	16	100	16	20	45	VN□□ 1604□□ 只装株洲刀片	WS061025	MV1603	S2 S3	MCL2114	MSP513
2020K16		20	20	125	20	25	45						
2525M16		25	25	150	25	32	45						
3225P16		32	25	170	32	32	45						
3232P16		32	25	170	32	32	45						
		32	32	170	32	40	45						

了解具体库存情况请致电厂家 详情请登陆网站www.hnsant.com

车削刀具 | TURNING TOOLS



External turning toolholders 外圆车刀

MVQNR/L

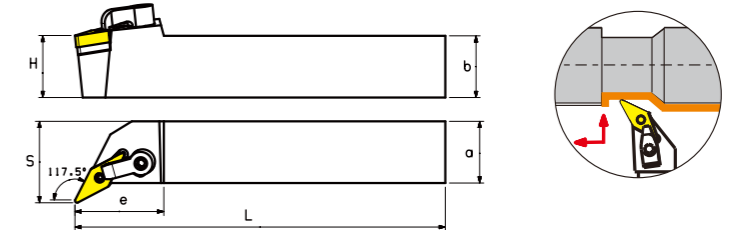

Type 型号	Dimension(mm) 基本尺寸							Applicable Inserts 使用的刀片	Clamping screw 双头螺钉	Shim 刀垫	Wrench 扳手	Clamp 压板	Clamping stud 销钉
	Stock 库存	a	b	L	h	s	e						
MVQNR/L 1616H16		16	16	100	16	24	36	VN□□ 1604□□ 只装株洲刀片	WS061025	MV1603	S2 S3	MCL2114	MSP513
2020K16		20	20	125	20	27	36						
2525M16		25	25	150	25	33	36						
3225P16		32	25	170	32	33	36						
3232P16		32	32	170	32	40	36						

MWLNR/L

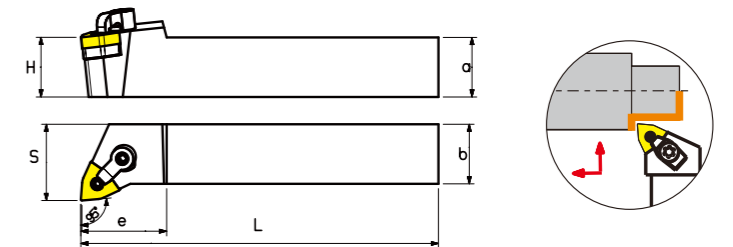

Type 型号	Dimension(mm) 基本尺寸							Applicable Inserts 使用的刀片	Clamping screw 双头螺钉	Shim 刀垫	Wrench 扳手	Clamp 压板	Clamping stud 销钉
	Stock 库存	a	b	L	h	s	e						
MWLNR/L 2020K06		20	20	125	20	25	28	WN□□ 0604□□	WS061025	MW0603	S2 S3	MCL1814	MSP513
2525M06		25	25	150	25	32	30		WS061030				
2020K08		20	20	125	20	26	28	WN□□ 0804□□	WS061025	MW0804	S3	MCL1814	MSP617
2525M08		25	25	150	25	32	35						
3225P08		32	25	170	32	32	35						
3232P08		32	32	170	32	40	35						

了解具体库存情况请致电厂家 详情请登陆网站www.hnsant.com

车削刀具 | TURNING TOOLS



外圆车刀 External turning toolholders

MRGNR

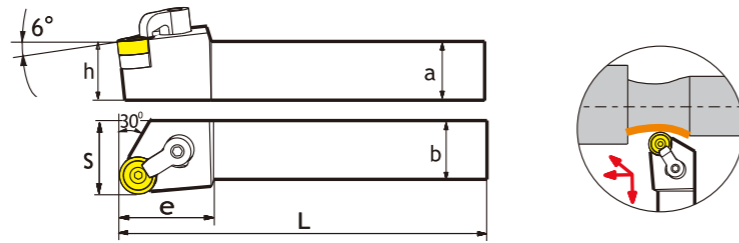

Type 型号	Dimension(mm) 基本尺寸							Applicable Inserts 使用的刀片	Clamping screw 双头螺钉	Shim 刀垫	Wrench 扳手	Clamp 压板	Clamping stud 销钉	
	Stock 库存		a	b	L	h	s							e
	R	L												
MRGNR/L 2020K12			20	20	125	20	25	28	RN□ 1204□	WS061025	MR1204	S3	MCL1814	MSP617
2525M12			25	25	150	25	32	32						
3225P12			32	25	170	32	32	32						
3232P12			32	32	170	32	39	32						

MRDNN

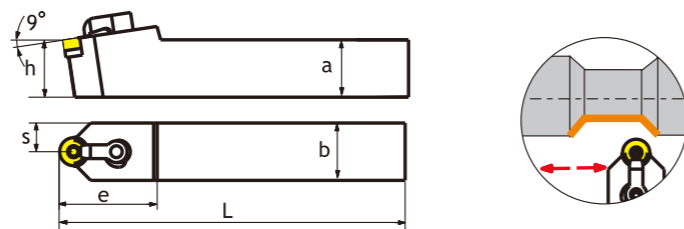

Type 型号	Dimension(mm) 基本尺寸							Applicable Inserts 使用的刀片	Clamping screw 双头螺钉	Shim 刀垫	Wrench 扳手	Clamp 压板	Clamping stud 销钉	
	Stock 库存		a	b	L	h	s							e
	R	L												
MRDNN 2020K12			20	20	125	20	10	30	RN□ 1204□	WS061025	MR1204	S3	MCL1814	MSP617
2525M12			25	25	150	25	12.5	32						
3225P12			32	25	170	32	12.5	30						
3232P12			32	32	170	32	16	30						

了解具体库存情况请致电厂家 详情请登陆网站www.hnsant.com

车削刀具 | TURNING TOOLS



External turning toolholders 外圆车刀

PCBNR/L

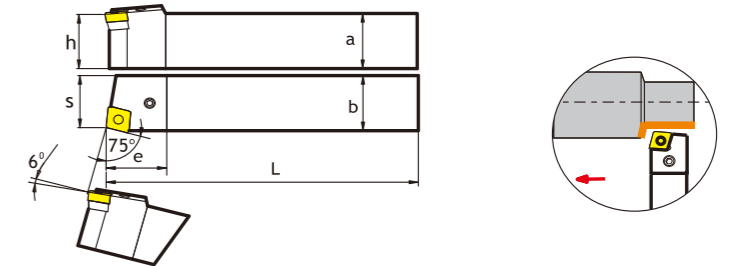

Type 型号	Dimension(mm) 基本尺寸							Applicable Inserts 使用的刀片	screw 螺钉	Shim 刀垫	Wrench 扳手	Lever 杠杆	Shim pin 档垫							
	Stock 库存		a	b	L	h	s							e						
	R	L																		
PCBNR/L 2020K12			20	20	125	20	17	30	CN□ 1204□	VHX0821	PC12318	S3	LV4	SP4						
2525M12			25	25	150	25	22	26												
3232P12			32	32	170	32	29	27												
2525M16			25	25	150	25	22	32							CN□ 1606□	VHX0825	PC16476	S3	LV5	SP5
3232P16			32	32	170	32	27	33												
3232P19			32	32	170	32	27	38												
4040S19			40	40	250	40	35	38							CN□ 1906□	VHX1027	PC19476	S4	LV6	SP6
4040S2507			40	40	250	40	37	50												
4040S2509			40	40	250	40	37	50												
									CN□ 2509□											

PCLNR/L

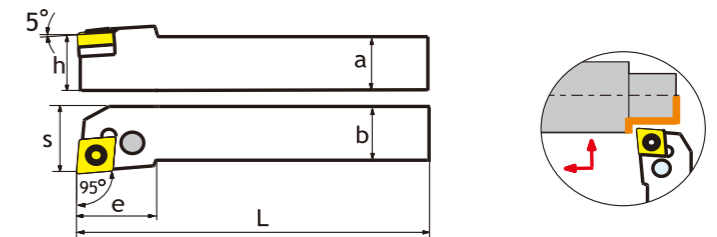

Type 型号	Dimension(mm) 基本尺寸							Applicable Inserts 使用的刀片	screw 螺钉	Shim 刀垫	Wrench 扳手	Lever 杠杆	Shim pin 档垫							
	Stock 库存		a	b	L	h	s							e						
	R	L																		
PCLNR/L 1616H09			16	16	100	16	20	20	CN□ 0903□	VHX0613	PC09318	S2.5	LV3	SP3						
2020K09			20	20	125	20	25	22												
2525M09			25	25	150	25	32	22												
2020K12			20	20	125	20	26	28							CN□ 1204□	VHX0821	PC12318	S3	LV4	SP4
2525M12			25	25	150	25	32	28												
3232P12			32	32	170	32	39	32												
2525M16			25	25	150	25	32	36							CN□ 1606□	VHX0825	PC16476	S3	LV5	SP5
3232P16			32	32	170	32	39	36												
3232P19			32	32	170	32	40	40												
4040S19			40	40	250	40	49	40	CN□ 1906□	VHX1027	PC19476	S4	LV6	SP6						
4040S2507			40	40	250	40	50	47												
4040S2509			40	40	250	40	50	47							CN□ 2507□	VHX1236	PC25	S5	LV8	SP8
									CN□ 2509□											

了解具体库存情况请致电厂家 详情请登陆网站www.hnsant.com

车削刀具 | TURNING TOOLS



外圆车刀 External turning toolholders

PDJNR/L

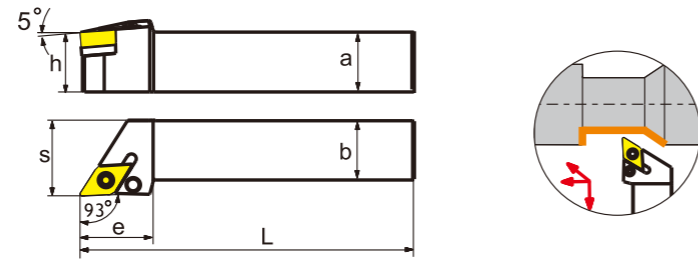

Type 型号	Dimension(mm) 基本尺寸							Applicable Inserts 使用的刀片	screw 螺钉	Shim 刀垫	Wrench 扳手	Lever 杠杆	Shim pin 档垫	
	Stock 库存		a	b	L	h	s							e
	R	L												
PDJNR/L	1616H11		16	16	100	16	20	25	DN□□ 1104□□	VHX0613	PD11270	S2.5	LV3	SP3
	2020K11		20	20	125	20	25	25						
	2525M11		25	25	150	25	30	30						
	2020K15		20	20	125	20	25	32	DN□□ 1506□□	VHX0825	PD15318	S3	LV4B	SP4
	2525M15		25	25	150	25	32	35						
	3232P15		32	32	170	32	38	35						
	2020K15-3		20	20	125	20	25	35	DN□□ 1504□□	VHX0821	PD15318	S3	LV4	SP4
	2525M15-3		25	25	150	25	32	35						
	3232P15-3		32	32	170	32	38	35						

PDNNR/L

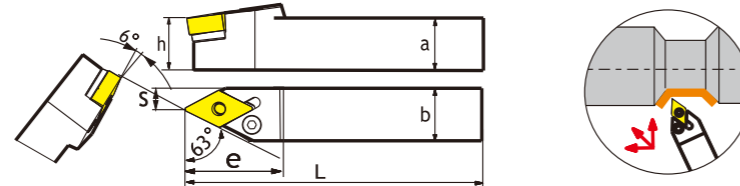

Type 型号	Dimension(mm) 基本尺寸							Applicable Inserts 使用的刀片	screw 螺钉	Shim 刀垫	Wrench 扳手	Lever 杠杆	Shim pin 档垫	
	Stock 库存		a	b	L	h	s							e
	R	L												
PDNNR/L	2020K15		20	20	125	20	8	37	DN□□ 1506□□	VHX0825	PD15318	S3	LV4B	SP4
	2525M15		25	25	150	25	12.5	37						
	3225P15		32	25	170	32	12.5	37						
	3232P15		32	32	170	32	16	37	DN□□ 1504□□	VHX0821	PD15318	S3	LV4	SP4
	2020K15-3		20	20	125	20	8	37						
	2525M15-3		25	25	150	25	12.5	37						
	3232P15-3		32	32	170	32	16	37						

了解具体库存情况请致电厂家 详情请登陆网站www.hnsant.com

车削刀具 | TURNING TOOLS



External turning toolholders 外圆车刀

PSBNR/L

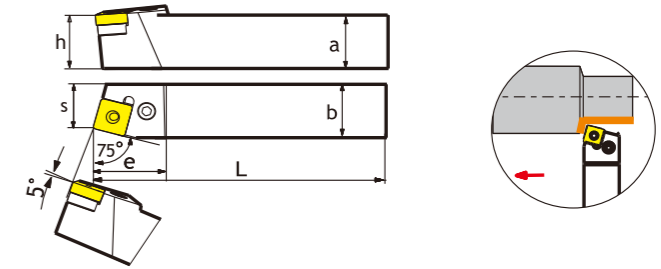

Type 型号	Dimension(mm) 基本尺寸							Applicable Inserts 使用的刀片	screw 螺钉	Shim 刀垫	Wrench 扳手	Lever 杠杆	Shim pin 档垫	
	Stock 库存		a	b	L	h	s							e
	R	L												
PSBNR/L	1616H09		16	16	100	16	13	21	SN□□ 0903□□	VHX0613	PS09318	S2.5	LV3	SP3
	2020K09		20	20	125	20	17	23						
	2020K12		20	20	125	20	17	28						
	2525M12		25	25	150	25	22	28	SN□□ 1204□□	VHX0821	PS12318	S3	LV4	SP4
	3225P12		32	25	170	32	22	28						
	3232P12		32	32	170	32	29	28						
	2525M15		25	25	150	25	22	32	SN□□ 1506□□	VHX0825	PS15476	S3	LV5	SP5
	3232P15		32	32	170	32	28	32						
	3232P19		32	32	170	32	36	45						
	4040S19		40	40	250	40	35	45	SN□□ 1906□□	VHX1027	PS19476	S4	LV6	SP6
	4040S2507		40	40	250	40	35	50						
	4040S2509		40	40	250	40	35	50						
										VHX1236	PS25634 PS25476	S5	LV8	SP8

PSDNN

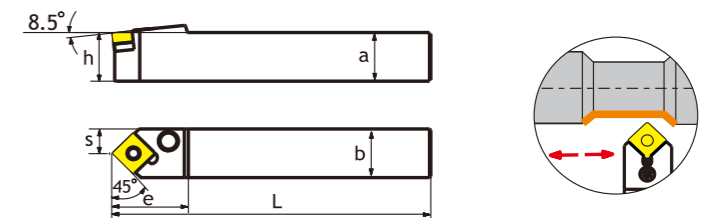

Type 型号	Dimension(mm) 基本尺寸							Applicable Inserts 使用的刀片	screw 螺钉	Shim 刀垫	Wrench 扳手	Lever 杠杆	Shim pin 档垫	
	Stock 库存		a	b	L	h	s							e
	R	L												
PSDNN	2020K12		20	20	125	20	10	30	SN□□ 1204□□	VHX0821	PS12318	S3	LV4	SP4
	2525M12		25	25	150	25	12.5	32						
	3232P12		32	32	170	32	16	30						
	2525M15		25	25	150	25	12.5	40	SN□□ 1506□□	VHX0825	PS15476	S3	LV5	SP5
	3232P15		32	32	170	32	16	40						
	3232P19		32	32	170	32	16	40						
	4040S19		40	40	250	40	20	40	SN□□ 1906□□	VHX1027	PS19476	S4	LV6	SP6
	4040S2507		40	40	250	40	20	50						
	4040S2509		40	40	250	40	20	50						
										VHX1236	PS25634 PS25476	S5	LV8	SP8

了解具体库存情况请致电厂家 详情请登陆网站www.hnsant.com

车削刀具 | TURNING TOOLS



外圆车刀 External turning toolholders

PSKNR/L

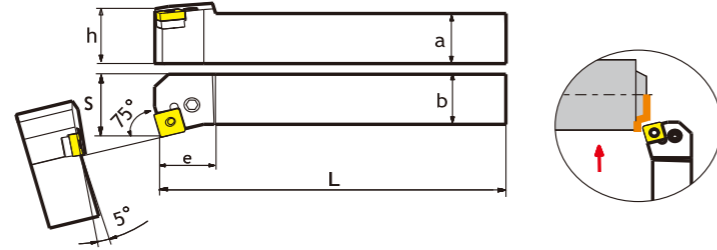

Type 型号	Dimension(mm) 基本尺寸							Applicable Inserts 使用的刀片	screw 螺钉	Shim 刀垫	Wrench 扳手	Lever 杠杆	Shim pin 档垫	
	Stock 库存		a	b	L	h	s							e
	R	L												
PSKNR/L	1616H09		16	16	100	16	20	17	SN□□ 0903□□	VHX0613	PS09318	S2.5	LV3	SP3
	2020K09		20	20	125	20	25	20						
	2020K12		20	20	125	20	25	26						
	2525M12		25	25	150	25	30	26	SN□□ 1204□□	VHX0821	PS12318	S3	LV4	SP4
	3232P12		32	32	170	32	38	26						
	2525M15		25	25	150	25	32	32						
	3232P15		32	32	170	32	38	32	SN□□ 1506□□	VHX0825	PS15476	S3	LV5	SP5
	3232P19		32	32	170	32	38	36						
	4040S19		40	40	250	40	48	32	SN□□ 1906□□	VHX1027	PS19476	S4	LV6	SP6
	4040S2507		40	40	250	40	50	40	SN□□ 2507□□	VHX1236	PS25634	S5	LV8	SP8
4040S2509		40	40	250	40	50	40	SN□□ 2509□□	VHX1236	PS25476				

PSSNR/L

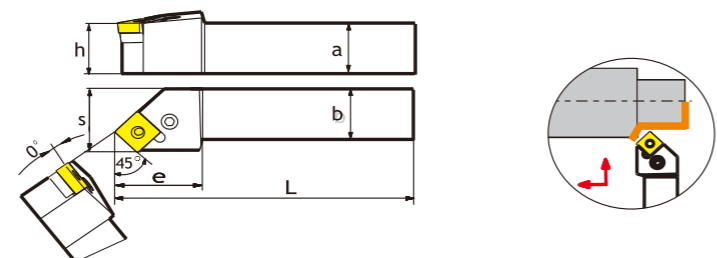

Type 型号	Dimension(mm) 基本尺寸							Applicable Inserts 使用的刀片	screw 螺钉	Shim 刀垫	Wrench 扳手	Lever 杠杆	Shim pin 档垫	
	Stock 库存		a	b	L	h	s							e
	R	L												
PSSNR/L	1616H09		16	16	100	16	18	25	SN□□ 0903□□	VHX0613	PS09318	S2.5	LV3	SP3
	2020K12		20	20	125	20	25	28						
	2525M12		25	25	150	25	30	32	SN□□ 1204□□	VHX0821	PS12318	S3	LV4	SP4
	3232P12		32	32	170	32	38	32						
	2525M15		25	25	150	25	30	35						
	3232P15		32	32	170	32	38	35	SN□□ 1506□□	VHX0825	PS15476	S3	LV5	SP5
	3232P19		32	32	170	32	38	40						
	4040S19		40	40	250	40	48	50	SN□□ 1906□□	VHX1027	PS19476	S4	LV6	SP6
	4040S2507		40	40	250	40	48	50	SN□□ 2507□□	VHX1236	PS25634	S5	LV8	SP8
	4040S2509		40	40	250	40	48	50	SN□□ 2509□□	VHX1236	PS25476			



车削刀具 | TURNING TOOLS

External turning toolholders 外圆车刀

PRDCN

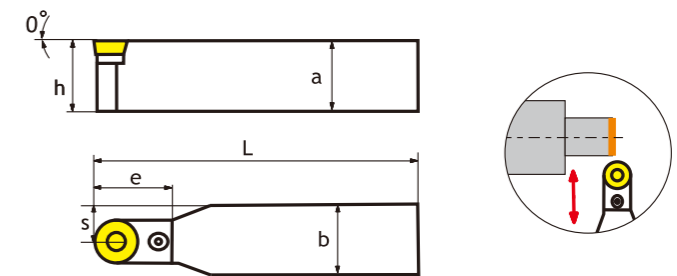

Type 型号	Dimension(mm) 基本尺寸							Applicable Inserts 使用的刀片	screw 螺钉	Shim 刀垫	Wrench 扳手	Lever 杠杆	Shim pin 档垫	
	Stock 库存		a	b	L	h	s							e
	R	L												
PRDCN	2020K12		20	20	125	20	10	25	RCMX1204□□	VHX0613	PR 1204	S2.5	LCL12C	SP3
	2525M12		25	25	150	25	12.5	25						
	2525M16		25	25	150	25	10	35						
	3232P16		32	32	170	32	16	32	RCMX1606□□	VHX0621	PR 1604	S2.5	LCL16C	SP4
	3232P20		32	32	170	32	16	40						
	4040T20		40	40	300	40	20	45	RCMX2006□□	VHX0825	PR 2004	S3	LCL20C	SP5
	3232P25		32	32	170	32	16	45						
	4040T25		40	40	300	40	20	50	RCMX2507□□	VHX1030	PR 2506	S4	LCL25C	SP6

PRACR/L

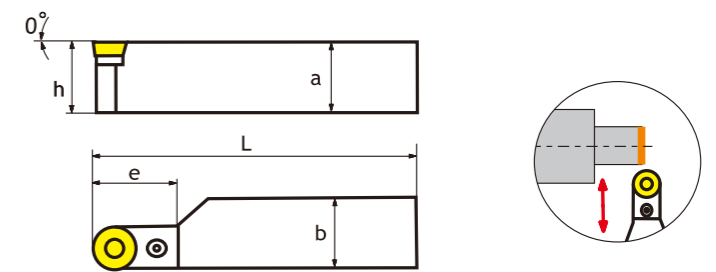

Type 型号	Dimension(mm) 基本尺寸							Applicable Inserts 使用的刀片	screw 螺钉	Shim 刀垫	Wrench 扳手	Lever 杠杆	Shim pin 档垫
	Stock 库存		a	b	L	h	e						
	R	L											
PRACR/L	2020K12		20	20	125	20	30						
	2525M12		25	25	150	25	30	RCMX1204□□	VHX0613	PR 1204	S2.5	LCL12C	SP3
	2525M16		25	25	150	25	35						
	3232P16		32	32	170	32	35	RCMX1606□□	VHX0621	PR 1604	S2.5	LCL16C	SP4
	3232P20		32	32	170	32	40						
	4040T20		40	40	300	40	50	RCMX2006□□	VHX0825	PR 2004	S3	LCL20C	SP5
	3232P25		32	32	170	32	45						
	4040T25		40	40	300	40	50	RCMX2507□□	VHX1030	PR 2506	S4	LCL25C	SP6

车削刀具 | TURNING TOOLS



外圆车刀 External turning toolholders

PRGCR/L

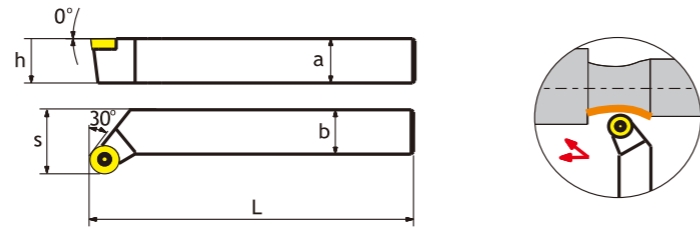

Type 型号	Dimension(mm) 基本尺寸						Applicable Inserts 使用的刀片	screw 螺钉	Shim 刀垫	Wrench 扳手	Lever 杠杆	Shim pin 档垫	
	Stock 库存		a	b	L	h							s
	R	L											
PRGCR/L	2020K12		20	20	125	20	25	RCMX1204□	VHX0613	PR 1204	S2.5	LCL12C	SP3
	2525M12		25	25	150	25	32						
	2525M16		25	25	150	25	35	RCMX1606□	VHX0621	PR 1604	S2.5	LCL16C	SP4
	3232P16		32	32	170	32	42						
	3232P20		32	32	170	32	40	RCMX2006□	VHX0825	PR 2004	S3	LCL20C	SP5
	4040T20		40	40	300	40	50						
	3232P25		32	32	170	32	45	RCMX2507□	VHX1030	PR 2506	S4	LCL25C	SP6
	4040T25		40	40	300	40	56						

PTGNR/L

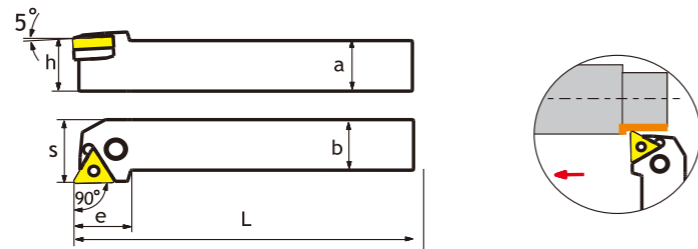

Type 型号	Dimension(mm) 基本尺寸								Applicable Inserts 使用的刀片	screw 螺钉	Shim 刀垫	Wrench 扳手	Lever 杠杆	Shim pin 档垫
	Stock 库存		a	b	L	h	s	e						
	R	L												
PTGNR/L	1616H11		16	16	100	16	19	18	TN□ 1103□	VHX059B	-	S2	LV2	-
	2020K11		20	20	125	20	24	20						
	2525M11		25	25	150	25	29	20						
	1616H16		16	16	100	16	19	22						
	2020K16		20	20	125	20	23	25	TN□ 1604□	VHX0617	PT16	S2.5	LV3	SP3
	2525M16		25	25	150	25	29	25						
	3232P16		32	32	170	32	37	32						
	2525M22		25	25	150	25	30	30	TN□ 2204□	VHX0821	PT22	S3	LV4	SP4
	3232P22		32	32	170	32	37	32						
	3232P27		32	32	170	32	37	38	TN□ 2706□	VHX0825	PT27	S3	LV5	SP5
4040S27		40	40	250	40	47	38							

了解具体库存情况请致电厂家 详情请登陆网站www.hnsant.com

车削刀具 | TURNING TOOLS



External turning toolholders 外圆车刀

PTFNR/L

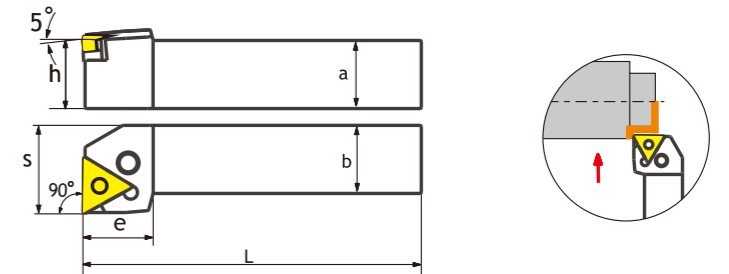

Type 型号	Dimension(mm) 基本尺寸								Applicable Inserts 使用的刀片	screw 螺钉	Shim 刀垫	Wrench 扳手	Lever 杠杆	Shim pin 档垫
	Stock 库存		a	b	L	h	s	e						
	R	L												
PTFNR/L	1616H16		16	16	100	16	20	20	TN□ 1604□	VHX0617	PT16	S2.5	LV3	SP3
	2020K16		20	20	125	20	25	20						
	2525M16		25	25	150	25	30	25						
	2525M22		25	25	150	25	32	30	TN□ 2204□	VHX0821	PT22	S3	LV4	SP4
	3232P22		32	32	170	32	38	30						
	3232P27		32	32	170	32	38	35	TN□ 2706□	VHX0825	PT27	S3	LV5	SP5
	4040S27		40	40	250	40	50	34						

PTTNR/L

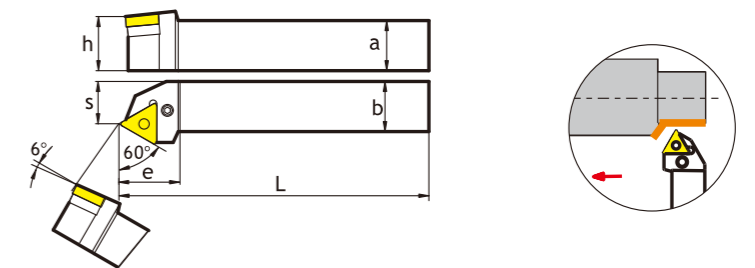

Type 型号	Dimension(mm) 基本尺寸								Applicable Inserts 使用的刀片	screw 螺钉	Shim 刀垫	Wrench 扳手	Lever 杠杆	Shim pin 档垫
	Stock 库存		a	b	L	h	s	e						
	R	L												
PTTNR/L	1616H16		16	16	100	16	13	25	TN□ 1604□	VHX0617	PT16	S2.5	LV3	SP3
	2020K16		20	20	125	20	17	25						
	2525M22		25	25	150	25	22	32	TN□ 2204□	VHX0821	PT22	S3	LV4	SP4

了解具体库存情况请致电厂家 详情请登陆网站www.hnsant.com

PWLNRL

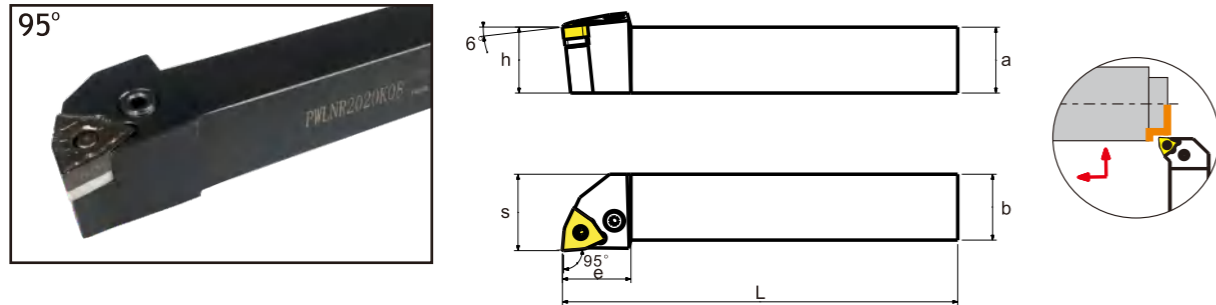

Type 型号	Dimension(mm) 基本尺寸							Applicable Inserts 使用的刀片	screw 螺钉	Shim 刀垫	Wrench 扳手	Lever 杠杆	Shim pin 档垫	
	Stock 库存		a	b	L	h	s							e
	R	L												
PWLNRL	1616H06		16	16	100	16	19	22	WN□□ 0604□□	VHX0617	PW06270	S2.5	LV3	SP3
	2020K06		20	20	125	20	23	25						
	2525M06		25	25	150	25	28	25						
	2020K08		20	20	125	20	25	26						
	2525M08		25	25	150	25	29	26						
3232P08		32	32	170	32	37	26	WN□□ 0804□□	VHX0821	PW08318	S3	LV4	SP4	

SCACRL

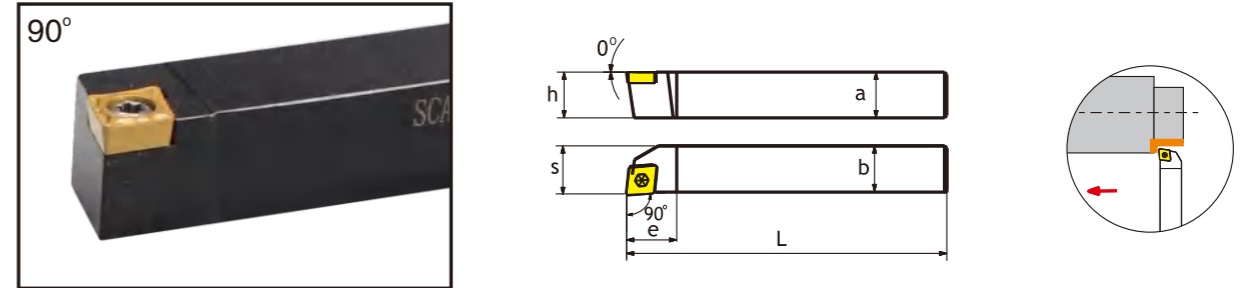

Type 型号	Dimension(mm) 基本尺寸							Applicable Inserts 使用的刀片	Screw 螺钉	Wrench 扳手	
	Stock 库存		a	b	L	h	s				e
	R	L									
SCACRL	1010E06		10	10	70	10	10.5	10	CC□T 0602□□	L60M2.5×5	T08
	1212F09		12	12	80	12	12.7	16			

SCLCRL

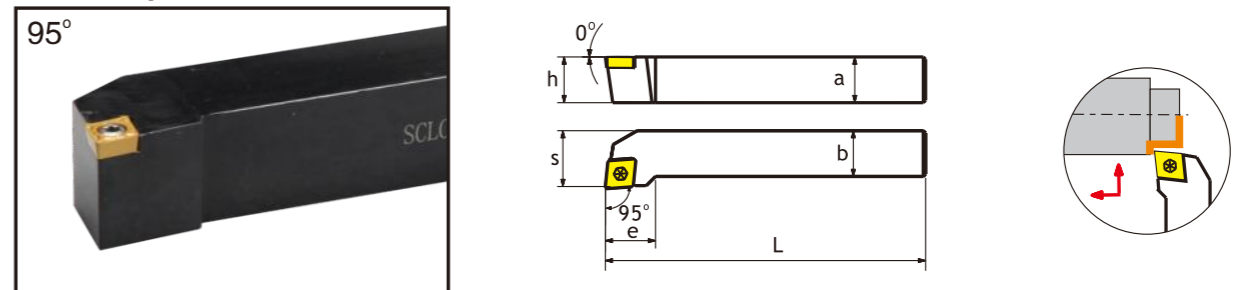

Type 型号	Dimension(mm) 基本尺寸							Applicable Inserts 使用的刀片	Screw 螺钉	Wrench 扳手	
	Stock 库存		a	b	L	h	s				e
	R	L									
SCLCRL	1212F09		12	12	80	12	15	16	CC□T 09T3□□	L60M4×8	T15
	1616H09		16	16	100	16	20	16			
	2020K09		20	20	125	20	23	20			
	2020K12		20	20	125	20	24	25	CC□T 1204□□	L60M5×12	T20
	2525M12		25	25	150	25	29	25			
	3225P12		32	25	170	32	29	25			
3232P12		32	32	170	32	36	38				

车削刀具 | TURNING TOOLS



外圆车刀 External turning toolholders

SDACR/L

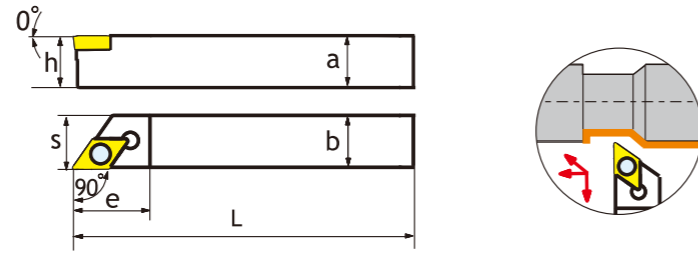
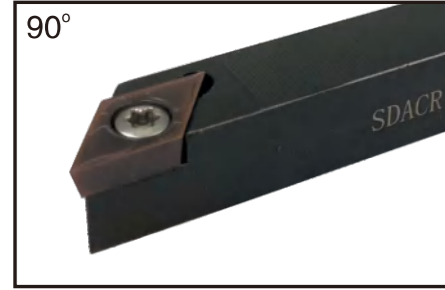

Type 型号	Dimension(mm) 基本尺寸							Applicable Inserts 使用的刀片	Screw 螺钉	Wrench 扳手	
	Stock 库存		a	b	L	h	s				e
	R	L									
SDACR/L	1010E07		10	10	70	10	10.5	15	DC ₀ T 0702□□	L60M2.5×5	T08
	1212F11		12	12	80	12	12.5	20			
	1616H11		16	16	100	16	16.7	20			

SDJCR/L

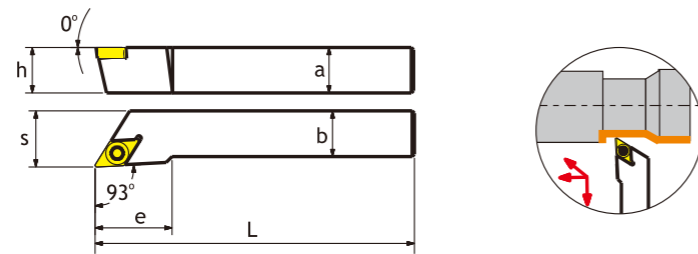

Type 型号	Dimension(mm) 基本尺寸							Applicable Inserts 使用的刀片	Screw 螺钉	Wrench 扳手	
	Stock 库存		a	b	L	h	s				e
	R	L									
SDJCR/L	1010E07		10	10	70	10	12	15	DC ₀ T 0702□□	L60M2.5×5	T08
	1212F07		12	12	80	12	14	15			
	1616H07		16	16	100	16	18	18			
	2020K07		20	20	125	20	22	18	DC ₀ T 11T3□□	L60M4×8	T15
	1616H11		16	16	100	16	19	20			
	2020K11		20	20	125	20	23	26			
	2525M11		25	25	150	25	28	26			
3225P11		32	25	170	32	28	26				
3232P11		32	32	170	32	35	31				



车削刀具 | TURNING TOOLS

External turning toolholders 外圆车刀

SDNCN

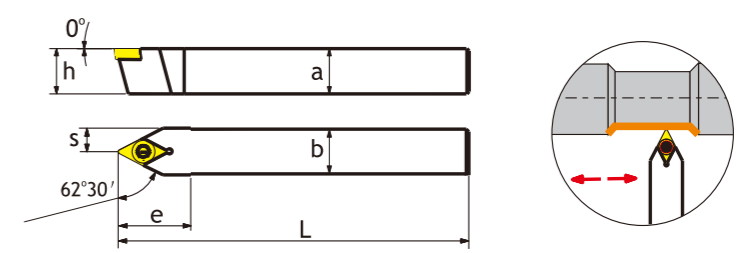

Type 型号	Dimension(mm) 基本尺寸							Applicable Inserts 使用的刀片	Screw 螺钉	Wrench 扳手	
	Stock 库存		a	b	L	h	s				e
	R	L									
SDNCN	1010E07		10	10	70	10	5	16	DC ₀ T 0702□□	L60M2.5×5	T08
	1212F07		12	12	80	12	6	20			
	1212H11		12	12	100	12	6	22			
	1616H11		16	16	100	16	8	22	DC ₀ T 11T3□□	L60M4×8	T15
	2020K11		20	20	125	20	10	22			
	2525M11		25	25	150	25	12.5	22			

SVJCR/L

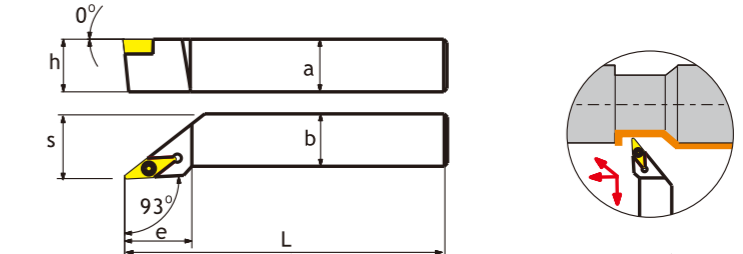
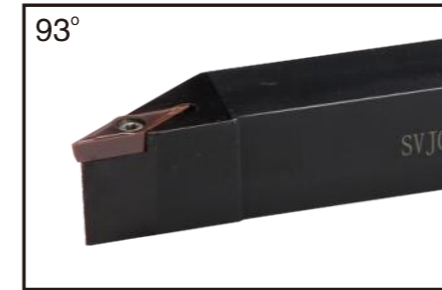

Type 型号	Dimension(mm) 基本尺寸							Applicable Inserts 使用的刀片	Screw 螺钉	Wrench 扳手	
	Stock 库存		a	b	L	h	s				e
	R	L									
SVJCR/L	1212F11		12	12	80	12	14	20	VC ₀ T 1103□□	L60M2.5×5	T08
	1616H11		16	16	100	16	18	22			
	2020K11		20	20	125	20	22	27			
	2525M11		25	25	150	25	27	35	VC ₀ T 1604□□	L60M4×8	T15
	1616H16		16	16	100	16	18	32			
	2020K16		20	20	125	20	22	32			
	2525M16		25	25	150	25	27	35			
	3225P16		32	25	170	32	27	35			
	3232P16		32	32	170	32	35	45			

车削刀具 | TURNING TOOLS



外圆车刀 External turning toolholders

SVJBR/L

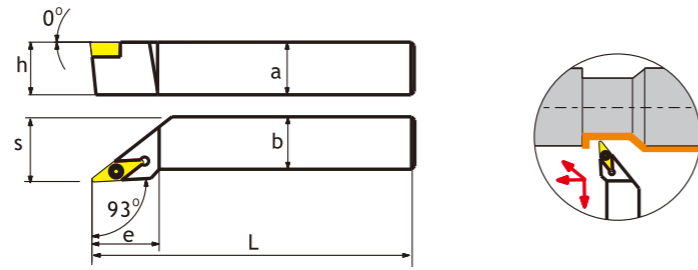
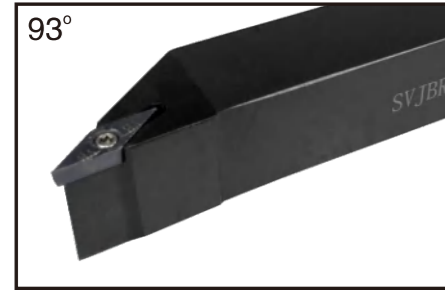

Type 型号	Dimension(mm) 基本尺寸							Applicable Inserts 使用的刀片	Screw 螺钉	Wrench 扳手	
	Stock 库存		a	b	L	h	s				e
	R	L									
SVJBR/L	1212F11		12	12	80	12	14	27	VB-T 1103□□	L60M2.5×5	T08
	1616H11		16	16	100	16	18	27			
	2020K11		20	20	125	20	22	27			
	2525M11		25	25	150	25	27	27			
	1616H16		16	16	100	16	18	36	VB-T 1604□□	L60M4×8	T15
	2020K16		20	20	125	20	22	41			
	2525M16		25	25	150	25	27	41			
	3225P16		32	25	170	32	27	41			
3232P16		32	32	170	32	35	41				

SVABR/L

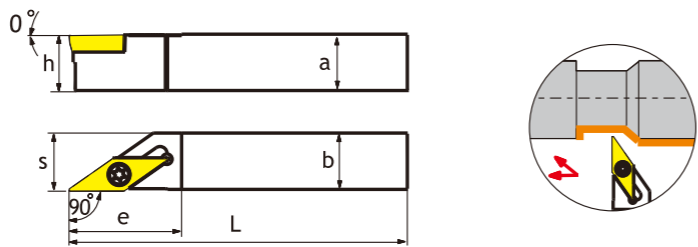

Type 型号	Dimension(mm) 基本尺寸							Applicable Inserts 使用的刀片	Screw 螺钉	Wrench 扳手	
	Stock 库存		a	b	L	h	s				e
	R	L									
SVABR/L	1616H16		16	16	100	16	16.5	32	VB-T 1604□□	L60M4×8	T15
	2020K16		20	20	125	20	20.5	32			
	2525M16		25	25	150	25	25.5	38			



车削刀具 | TURNING TOOLS

External turning toolholders 外圆车刀

SVACR/L

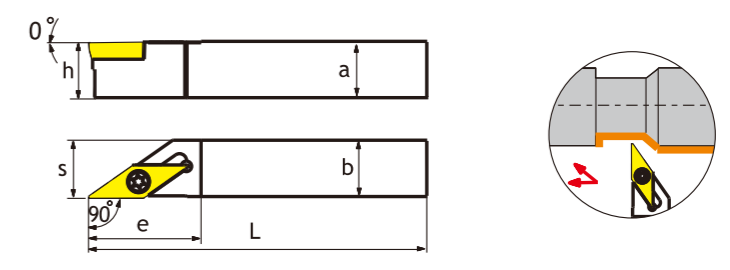

Type 型号	Dimension(mm) 基本尺寸							Applicable Inserts 使用的刀片	Screw 螺钉	Wrench 扳手	
	Stock 库存		a	b	L	h	s				e
	R	L									
SVACR/L	1616H16		16	16	100	16	16.5	32	VC-T 1604□□	L60M4×8	T15
	2020K16		20	20	125	20	20.5	32			
	2525M16		25	25	150	25	25.5	38			

SVVBN

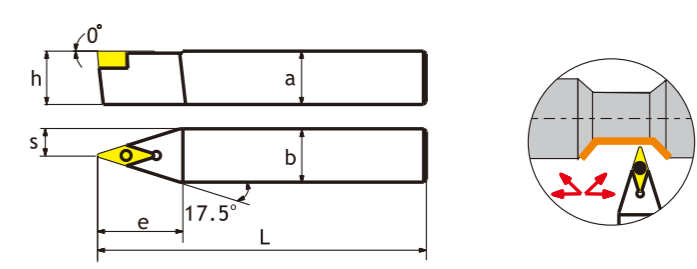
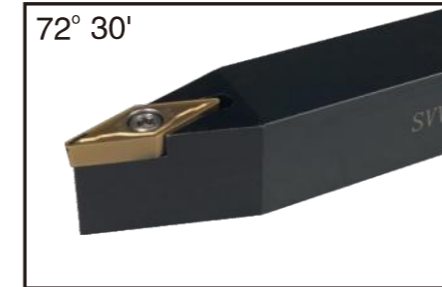

Type 型号	Dimension(mm) 基本尺寸							Applicable Inserts 使用的刀片	Screw 螺钉	Wrench 扳手	
	Stock 库存		a	b	L	h	s				e
	R	L									
SVVBN	1212F11		12	12	80	12	6	22	VB-T 1103□□	L60M2.5×5	T08
	1616H11		16	16	100	16	8	27			
	2020K11		20	20	125	20	10	30			
	1616H16		16	16	100	16	8	33			
	2020K16		20	20	125	20	10	33	VB-T 1604□□	L60M4×8	T15
	2525M16		25	25	150	25	12.5	38			
	3225P16		32	25	170	32	12.5	38			
	3232P16		32	32	170	32	16	38			

车削刀具 | TURNING TOOLS



外圆车刀 External turning toolholders

SVVCN

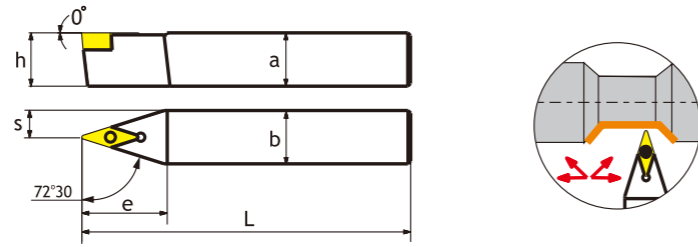

Type 型号	Dimension(mm) 基本尺寸							Applicable Inserts 使用的刀片	Screw 螺钉	Wrench 扳手	
	Stock 库存	a	b	L	h	s	e				
SVVCN	1212F11		12	12	80	12	6	22	VC ₀ T 1103□□	L60M2.5×5	T08
	1616H11		16	16	100	16	8	27			
	2020K11		20	20	125	20	10	30			
	1616H16		16	16	100	16	8	33			
	2020K16		20	20	125	20	10	33			
SVVCN	2525M16		25	25	150	25	12.5	38	VC ₀ T 1604□□	L60M4×8	T15
	3225P16		32	25	170	32	12.5	38			
	3232P16		32	32	170	32	16	38			

SSBCR/L

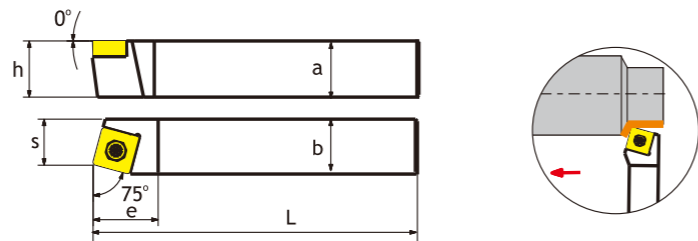

Type 型号	Dimension(mm) 基本尺寸							Applicable Inserts 使用的刀片	Screw 螺钉	Wrench 扳手	
	Stock 库存	a	b	L	h	s	e				
SSBCR/L	1212F09		12	12	80	12	11	14	SC ₀ T 09T3□□	L60M4×8	T15
	1616H09		16	16	100	16	13	16			
	2020K12		20	20	125	20	17	25			
	2525M12		25	25	150	25	22	25			
	3232P12		32	32	170	32	27	28			
SSBCR/L	2525M12		25	25	150	25	22	25	SC ₀ T 1204□□	L60M5×12	T20
	3232P12		32	32	170	32	27	28			

了解具体库存情况请致电厂家 详情请登陆网站www.hnsant.com



车削刀具 | TURNING TOOLS

外圆车刀 External turning toolholders

SSDCN

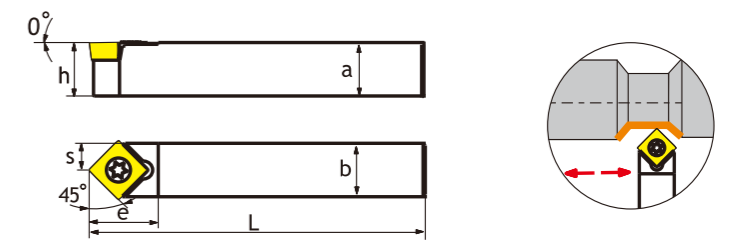

Type 型号	Dimension(mm) 基本尺寸							Applicable Inserts 使用的刀片	Screw 螺钉	Wrench 扳手	
	Stock 库存	a	b	L	h	s	e				
SSDCN	1212F09		12	12	80	12	6	16	SC ₀ T 09T3□□	L60M4×8	T15
	1616H09		16	16	100	16	8	16			
	2020K09		20	20	125	20	10	16			
	2525M09		25	25	150	25	12.5	25			
	2020K12		20	20	125	20	10	25			
	2525M12		25	25	150	25	12.5	25			
SSDCN	3232P12		32	32	170	32	16	25	SC ₀ T 1204□□	L60M5×12	T20

SSKCR/L

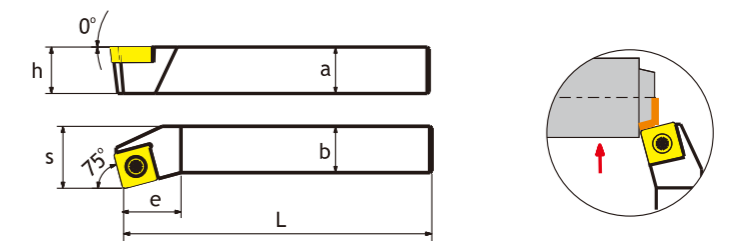

Type 型号	Dimension(mm) 基本尺寸							Applicable Inserts 使用的刀片	Screw 螺钉	Wrench 扳手	
	Stock 库存	a	b	L	h	s	e				
SSKCR/L	1616H09		16	16	100	16	20	13	SC ₀ T 09T3□□	L60M4×8	T15
	2020K09		20	20	125	20	25	18			
	2020K12		20	20	125	20	25	18			
	2525M12		25	25	150	25	32	22			
	3232P12		32	32	170	32	40	27			
SSKCR/L	2525M12		25	25	150	25	32	22	SC ₀ T 1204□□	L60M5×12	T20
	3232P12		32	32	170	32	40	27			

了解具体库存情况请致电厂家 详情请登陆网站www.hnsant.com

车削刀具 | TURNING TOOLS



外圆车刀 External turning toolholders

SSSCR/L

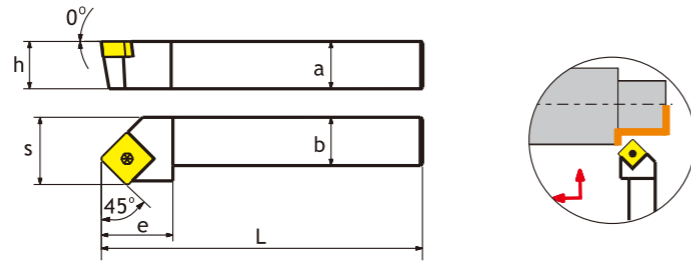

Type 型号	Dimension(mm) 基本尺寸								Applicable Inserts 使用的刀片	Screw 螺钉	Wrench 扳手
	Stock 库存		a	b	L	h	s	e			
	R	L									
SSSCR/L	1616H09		16	16	100	16	20	16	SC ₀ T 09T3 ₀₀	L60M4×8	T15
	2020K09		20	20	125	20	25	20			
	2020K12		20	20	125	20	25	23			
	2525M12		25	25	150	25	32	25			
	3232P12		32	32	170	32	38	28			
									SC ₀ T 1204 ₀₀	L60M5×12	T20

STACR/L

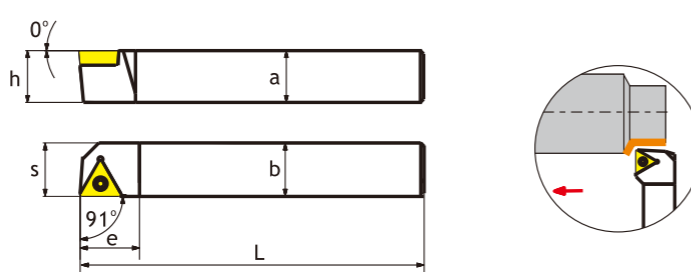

Type 型号	Dimension(mm) 基本尺寸								Applicable Inserts 使用的刀片	Screw 螺钉	Wrench 扳手
	Stock 库存		a	b	L	h	s	e			
	R	L									
STACR/L	1212F11		12	12	80	12	12.5	14	TC ₀ T 1102 ₀₀	L60M2.5×5	T08



车削刀具 | TURNING TOOLS

External turning toolholders 外圆车刀

STFCR/L

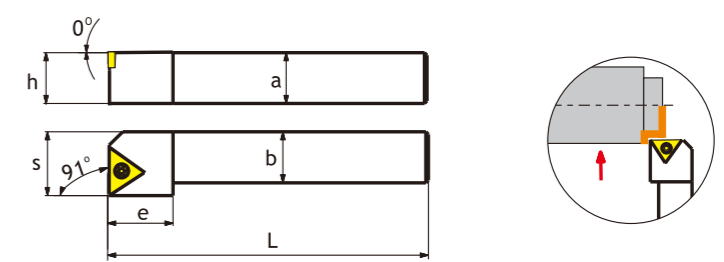

Type 型号	Dimension(mm) 基本尺寸								Applicable Inserts 使用的刀片	Screw 螺钉	Wrench 扳手
	Stock 库存		a	b	L	h	s	e			
	R	L									
STFCR/L	1212F11		12	12	80	12	14	14	TC ₀ T 1102 ₀₀	L60M2.5×5	T08
	1616H11		16	16	100	16	18	16			
	2020K11		20	20	125	20	22	16			
	1616H16		16	16	100	16	18	19	TC ₀ T 16T3 ₀₀	L60M4×8	T15
	2020K16		20	20	125	20	22	19			
	2525M16		25	25	150	25	27	24			

STGCR/L

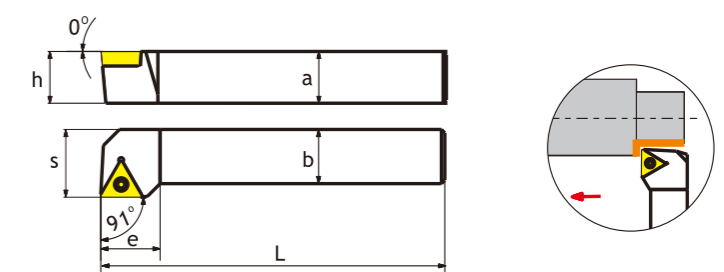

Type 型号	Dimension(mm) 基本尺寸								Applicable Inserts 使用的刀片	Screw 螺钉	Wrench 扳手
	Stock 库存		a	b	L	h	s	e			
	R	L									
STGCR/L	0808D09		08	08	60	8	10	11	TC ₀ T 0902 ₀₀	L60M2.2×5	T06
	1010E09		10	10	70	10	11	11			
	1212F11		12	12	80	12	14	14	TC ₀ T 1102 ₀₀	L60M2.5×5	T08
	1616H11		16	16	100	16	17	16			
	2020K16		20	20	125	20	22	21	TC ₀ T 16T3 ₀₀	L60M4×8	T15
	2525M16		25	25	150	25	27	21			

车削刀具 | TURNING TOOLS



外圆车刀 External turning toolholders

STTCR/L

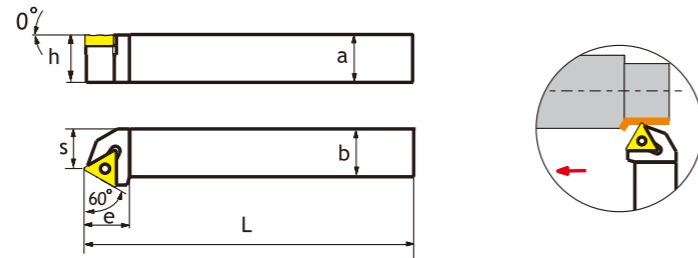

Type 型号	Dimension(mm) 基本尺寸							Applicable Inserts 使用的刀片	Screw 螺钉	Wrench 扳手	
	Stock 库存		a	b	L	h	s				e
	R	L									
STTCR/L	1616H11		16	16	100	16	13	14	TC-T 1102□□	L60M2.5 × 5	T08
	1616H16		16	16	100	16	13	19			
	2020K16		20	20	125	20	17	19			

SWACR/L

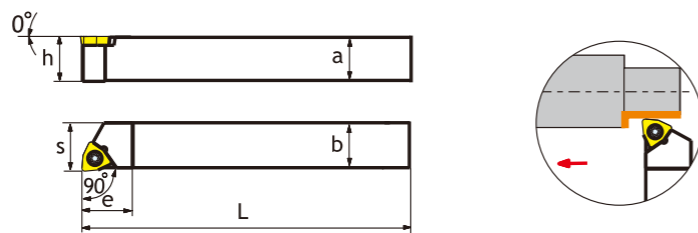

Type 型号	Dimension(mm) 基本尺寸							Applicable Inserts 使用的刀片	Screw 螺钉	Wrench 扳手	
	Stock 库存		a	b	L	h	s				e
	R	L									
SWACR/L	1010E04		10	10	70	10	10.5	10	WC-X 0402□□	L60M2.5 × 5	T08
	1212F04		12	12	80	12	12.5	14			
	1616H06		16	16	100	16	16.5	20			
	2020K08		20	20	125	20	20.5	24			

了解具体库存情况请致电厂家 详情请登陆网站www.hnsant.com

车削刀具 | TURNING TOOLS



External turning toolholders 外圆车刀

SRDCN

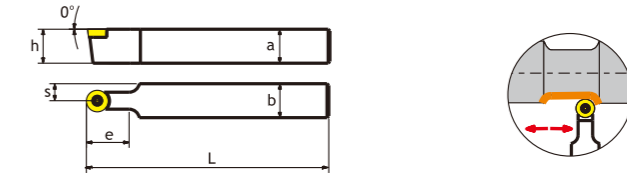

Type 型号	Dimension(mm) 基本尺寸							Applicable Inserts 使用的刀片	Screw 刀片螺钉	Wrench 扳手	Shim 刀垫	Screw 刀垫螺钉	Wrench 刀垫扳手	
	Stock 库存		a	b	L	h	s							e
	R	L												
SRDCN	2020K06		20	20	125	20	10	11	RC-T 0602□□	L60M2.5 × 5	T08	-	-	-
	2525M06		25	25	150	25	12.5	11						
	2020K08		20	20	125	20	10	16						
	2525M08		25	25	150	25	12.5	16	RC-T 10T3□□	L60M3.5 × 10	T15	-	-	-
	2020K10		20	20	125	20	10	25						
	2525M10		25	25	150	25	12.5	25						
	2020K12		20	20	125	20	10	35	RC-T 1204□□	L60M3.5 × 12	T15	-	-	-
	2525M12		25	25	150	25	12.5	35						
	3225P12		32	25	170	32	16	35						
	2525M16		25	25	150	25	12.5	35	RC-T 1606□□	L60M4 × 16	T20	R16BS	SM0614	S4
	3232P16		32	32	170	32	16	40						
	3232P20		32	32	170	32	16	40						
	4040S20		40	40	250	40	20	40	RCMX2006	L60M5 × 16-8.1	T20	R20BS	SM0814	S5

SRGCR/L

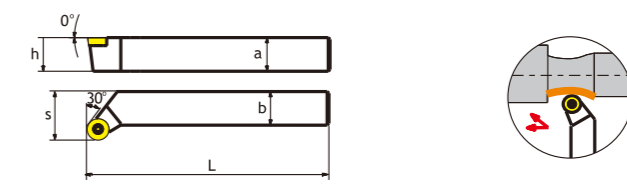

Type 型号	Dimension(mm) 基本尺寸							Applicable Inserts 使用的刀片	Screw 刀片螺钉	Wrench 扳手	Shim 刀垫	Screw 刀垫螺钉	Wrench 刀垫扳手
	Stock 库存		a	b	L	h	s						
	R	L											
SRGCR/L	2020K10		20	20	125	20	25	RC-T 10T3□□	L60M3.5 × 10	T15	-	-	-
	2525M10		25	25	150	25	32						
	2020K12		20	20	125	20	27						
	2525M12		25	25	150	25	32	RC-T 1204□□	L60M3.5 × 12	T15	-	-	-
	3232P12		32	32	170	32	32						
	2525M16		25	25	150	25	32						
	3232P16		32	32	170	32	40	RC-T 1606□□	L60M4 × 16	T20	R16BS	SM0614	S4
	3232P20		32	32	170	32	40						
	4040S20		40	40	250	40	48						

了解具体库存情况请致电厂家 详情请登陆网站www.hnsant.com

车削刀具 | TURNING TOOLS



外圆车刀 External turning toolholders

SRACR/L

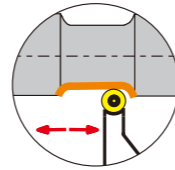
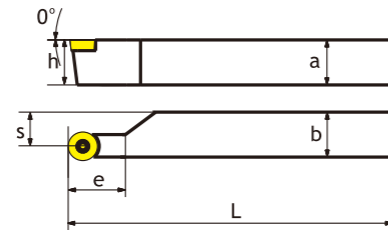
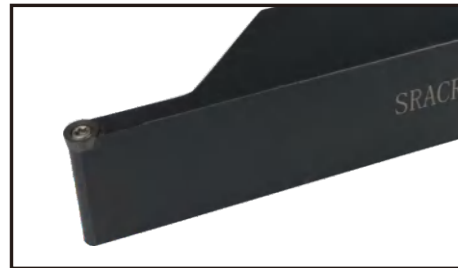

Type 型号	Dimension(mm) 基本尺寸						Applicable Inserts 使用的刀片	Screw 刀片螺钉	Wrench 扳手	Shim 刀垫	Screw 刀垫螺钉	Wrench 刀垫扳手
	Stock 库存	a	b	L	h	e						
SRACR/L	2020K06		20	20	125	20	15	RC-T 0602	L60M2.5 x 5	T08	-	-
	2525M06		25	25	150	25	23					
	2020K08		20	20	125	20	18	RC-T 0803	L60M3 x 7	T09	-	-
	2525M08		25	25	150	25	23					
	2020K10		20	20	125	20	20	RC-T 10T3	L60M3.5 x 10	T15	-	-
	2525M10		25	25	150	25	25					
	2020K12		20	20	125	20	28					
	2525M12		25	25	150	25	28	RC-T 1204	L60M3.5 x 12	T15	-	-
	3225P12		32	25	170	32	28					
	2525M16		25	25	150	25	35	RC-T 1606	L60M4 x 16	T15	R16BS	SM0614
3232P16		32	32	170	32	40						
3232P20		32	32	170	32	40						
4040S20		40	40	250	40	55	RCMX2006	L60M5 x 16-8.1	T20	R20BS	SM0814	



车削刀具 | TURNING TOOLS

External turning toolholders 外圆车刀

CCLNR/L

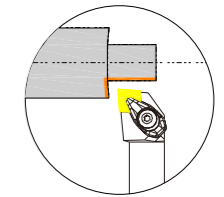
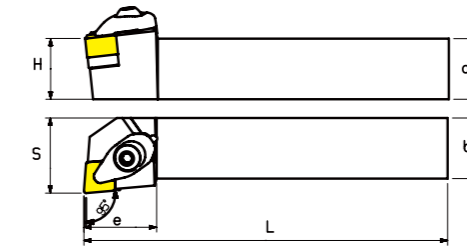

Type 型号	Dimension(mm) 基本尺寸							Applicable Inserts 使用的刀片	Shim 刀垫	Wrench 扳手	Clamp 压板	Clamp screw 压板螺丝	screw 螺钉	
	Stock 库存	a	b	L	h	s	e							
CCLNR/L	2020K12		20	20	125	20	26	32	CN 1207	MC 1204	S4,S3	CCL2612	DM 0625	DSP 0612
	2525M12		25	25	150	25	31	31						
	2525M16		25	25	150	25	32	36	CN 1606	MC 1604	S4	CCL2816	DM 0830	DSP 0812
	3225P16		32	25	170	32	32	36						

CDJNR/L

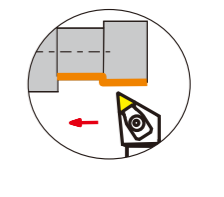
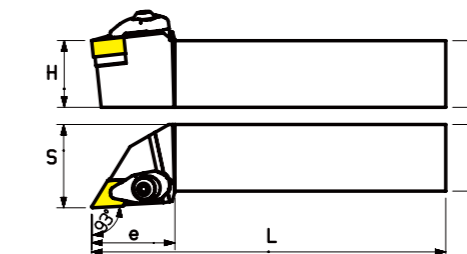

Type 型号	Dimension(mm) 基本尺寸							Applicable Inserts 使用的刀片	Shim 刀垫	Wrench 扳手	Clamp 压板	Clamp screw 压板螺丝	screw 螺钉	
	Stock 库存	a	b	L	h	s	e							
CDJNR/L	2525M15		25	25	150	25	32	40	DN 1507	MD 1504	S4,S3	CCL2612	DM 0625	DSP 0612
	3225P15		32	25	170	32	32	40						

车削刀具 | TURNING TOOLS



外圆车刀 External turning toolholders

CSKNR/L

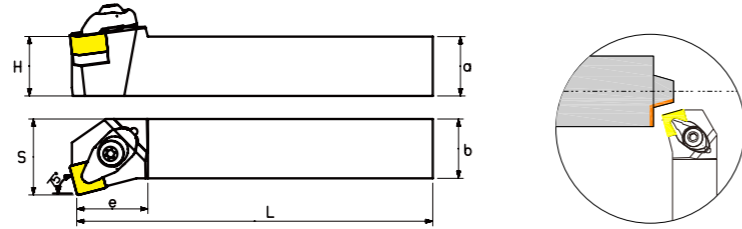

Type 型号	Dimension(mm) 基本尺寸								Applicable Inserts 使用的刀片	Shim 刀垫	Wrench 扳手	Clamp 压板	Clamp screw 压板螺丝	screw 螺钉
	Stock 库存		a	b	L	h	s	e						
	R	L												
CSKNR/L	2020K12		20	20	125	20	26	28	SN □□ 1207□□	MS 1204	S4,S3	CCL2612	DM 0625	DSP 0612
	2525M12		25	25	150	25	32	30						
	3225P12		32	25	170	32	32	30						

CSDNN

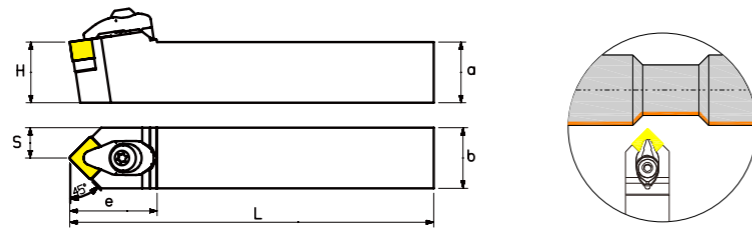

Type 型号	Dimension(mm) 基本尺寸								Applicable Inserts 使用的刀片	Shim 刀垫	Wrench 扳手	Clamp 压板	Clamp screw 压板螺丝	screw 螺钉
	Stock 库存		a	b	L	h	s	e						
	R	L												
CSDNN	2020K12		20	20	125	20	10	36	SN □□ 1207□□	MS 1204	S4,S3	CCL2612	DM 0625	DSP 0612
	2525M12		25	25	150	25	12.5	36						
	3225P12		32	25	170	32	12.5	36						



车削刀具 | TURNING TOOLS

External turning toolholders 外圆车刀

CSRNR/L

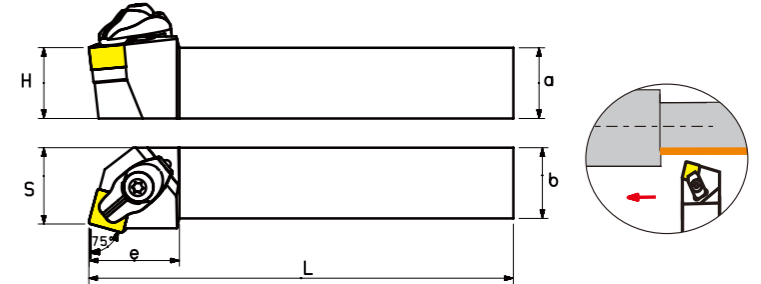

Type 型号	Dimension(mm) 基本尺寸								Applicable Inserts 使用的刀片	Shim 刀垫	Wrench 扳手	Clamp 压板	Clamp screw 压板螺丝	screw 螺钉
	Stock 库存		a	b	L	h	s	e						
	R	L												
CSRNR/L	2020K12		20	20	125	20	22	32	SN □□ 1207□□	MS 1204	S4,S3	CCL2612	DM 0625	DSP 0612
	2525M12		25	25	150	25	27	32						
	3225P12		32	25	170	32	27	32						
	3225P15		32	25	170	32	32	40						
	4040R15		40	40	200	40	43	40						

CRDNN

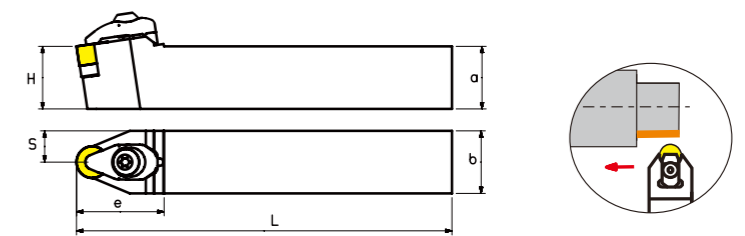

Type 型号	Dimension(mm) 基本尺寸								Applicable Inserts 使用的刀片	Shim 刀垫	Wrench 扳手	Clamp 压板	Clamp screw 压板螺丝	screw 螺钉
	Stock 库存		a	b	L	h	s	e						
	R	L												
CRDNN	2020K12		20	20	125	20	10	36	RN □□ 1207□□	MR1204	S3,S4	CCL2612	DM 0625	DSP 0612
	2525M12		25	25	150	25	12.5	36						
	3225P12		32	25	170	32	12.5	36						

车削刀具 | TURNING TOOLS



外圆车刀 External turning toolholders

CTJNR/L

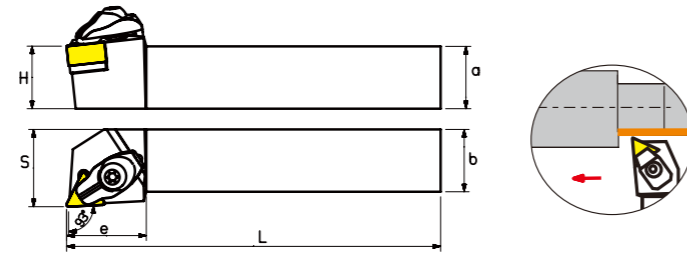
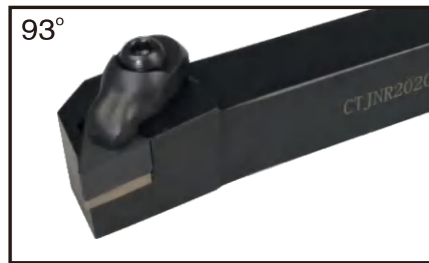

Type 型号	Dimension(mm) 基本尺寸							Applicable Inserts 使用的刀片	Shim 刀垫	Wrench 扳手	Clamp 压板	Clamp screw 压板螺丝	screw 螺钉	
	Stock 库存		a	b	L	h	s							e
	R	L												
CTJNR/L	2020K16		20	20	125	20	26	32	TN □□ 1607□□	MT 1603	S4,S3	CCL2612	DM 0625	DSP 0510
	2525M16		25	25	150	25	31	32						

CTUNR/L

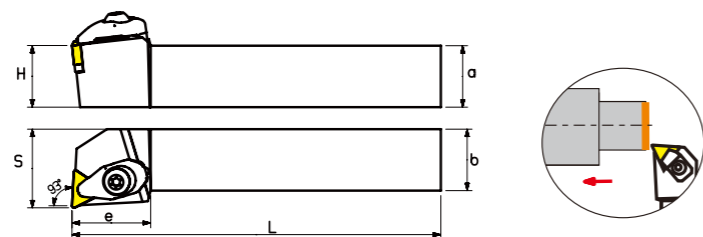

Type 型号	Dimension(mm) 基本尺寸							Applicable Inserts 使用的刀片	Shim 刀垫	Wrench 扳手	Clamp 压板	Clamp screw 压板螺丝	screw 螺钉	
	Stock 库存		a	b	L	h	s							e
	R	L												
CTUNR/L	2020K16		20	20	125	20	25	32	TN □□ 1607□□	MT 1603	S4,S3	CCL2612	DM 0625	DSP 0510
	2525M16		25	25	150	25	32	32						



车削刀具 | TURNING TOOLS

External turning toolholders 外圆车刀

DCLNR/L

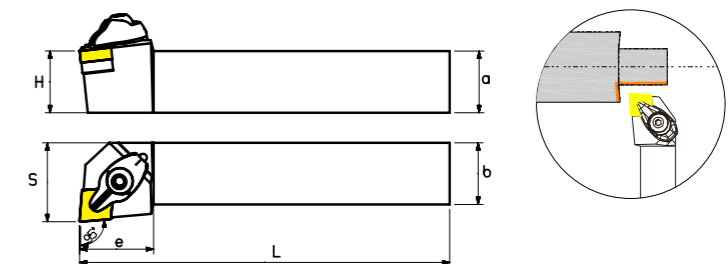

Type 型号	Dimension(mm) 基本尺寸							Applicable Inserts 使用的刀片	Shim 刀垫	Wrench 扳手	Clamp 压板	Clamp screw 压板螺丝	screw 螺钉	
	Stock 库存		a	b	L	h	s							e
	R	L												
DCLNR/L	2020K12		20	20	125	20	27	32	CN □□ 1204□□	MC 1204	S4, S3	DCL2612	DM 0625	DSP 0612
	2525M12		25	25	150	25	32	30						
	3232P12		32	32	170	32	39	30						
	2525M16		25	25	150	25	32	36	CN □□ 1604□□	DC 16635	T20, S4	DLM 5	DM 0625	L60 M5X12
	3232P16		32	32	170	32	40	36						
	3232P19		32	32	170	32	40	40						
4040R19		40	40	200	40	50	40	CN □□ 1906□□	MC 1904	S6, S4	DCL1934 (机加)	M8X35	DSP 0814	

DCBNR/L

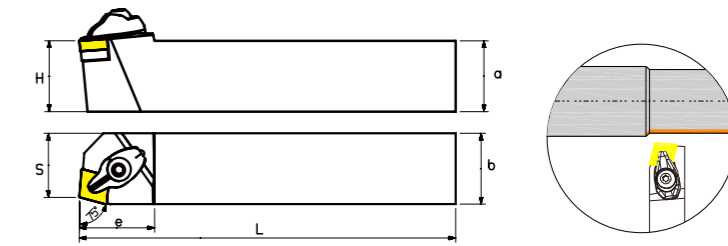

Type 型号	Dimension(mm) 基本尺寸							Applicable Inserts 使用的刀片	Shim 刀垫	Wrench 扳手	Clamp 压板	Clamp screw 压板螺丝	screw 螺钉	
	Stock 库存		a	b	L	h	s							e
	R	L												
DCBNR/L	2020K12		20	20	125	20	17	32	CN □□ 1204□□	MC 1204	S4, S3	DCL2612	DM 0625	DSP 0612
	2525M12		25	25	150	25	22	30						
	3232P12		32	32	170	32	29	30						
	2525M16		25	25	150	25	23	36	CN □□ 1604□□	DC 16635	T20, S4	DLM 5	DM 0625	L60 M5X12
	3232P16		32	32	170	32	29	36						
	3232P19		32	32	170	32	28	40						
4040R19		40	40	200	40	36	40	CN □□ 1906□□	MC 1904	S6, S4	DCL1934 (机加)	M8X35	DSP 0814	

车削刀具 | TURNING TOOLS



外圆车刀 External turning toolholders

DCKNR/L

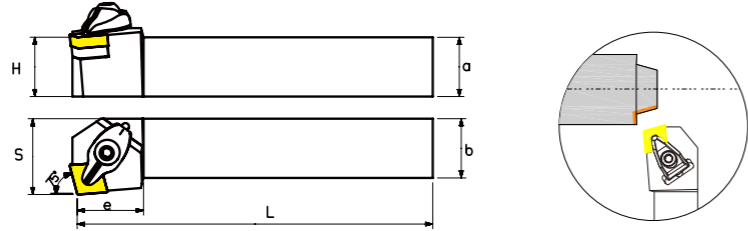

Type 型号	Dimension(mm) 基本尺寸							Applicable Inserts 使用的刀片	Shim 刀垫	Wrench 扳手	Clamp 压板	Clamp screw 压板螺丝	screw 螺钉	
	Stock 库存		a	b	L	h	s							e
	R	L												
DCKNR/L	2020K12		20	20	125	20	26	28	CN □□ 1204□□	MC 1204	S3、S4	DCL2612	DM 0625	DSP 0612
	2525M12		25	25	150	25	32	28						
	3232P12		32	32	170	32	39	28						

DCMNN

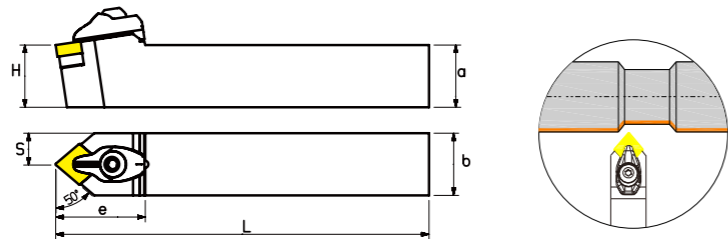

Type 型号	Dimension(mm) 基本尺寸							Applicable Inserts 使用的刀片	Shim 刀垫	Wrench 扳手	Clamp 压板	Clamp screw 压板螺丝	screw 螺钉	
	Stock 库存		a	b	L	h	s							e
	R	L												
DCMNN	2020K12		20	20	125	20	10	36	CN □□ 1204□□	MC 1204	S3、S4	DCL2612	DM 0625	DSP 0612
	2525M12		25	25	150	25	12.5	36						
	3232P12		32	32	170	32	16	36						

了解具体库存情况请致电厂家 详情请登陆网站www.hnsant.com



车削刀具 | TURNING TOOLS

外圆车刀 External turning toolholders

DDJNR/L

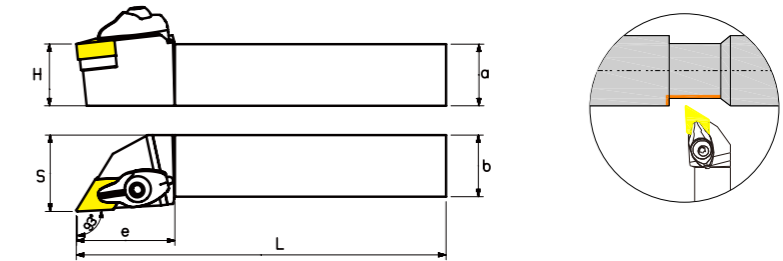

Type 型号	Dimension(mm) 基本尺寸							Applicable Inserts 使用的刀片	Shim 刀垫	Wrench 扳手	Clamp 压板	Clamp screw 压板螺丝	screw 螺钉	
	Stock 库存		a	b	L	h	s							e
	R	L												
DDJNR/L	2020K11		20	20	125	20	25	32	DN □□ 1104□□	MD 1103	S3	DCL2211	DM 0520	DSP 0510
	2525M11		25	25	150	25	30	32						
	2020K1504		20	20	125	20	25	40	DN□□ 1504□□	MD 1504	S4, S3	DCL2612	DM 0625	DSP 0612
	2525M1504		25	25	150	25	31	40						
	3232P1504		32	32	170	32	39	40						
	2020K1506		20	20	125	20	25	40	DN□□ 1506□□	MD 1504	S4, S3	DCL2612	DM 0625	DSP 0612
	2525M1506		25	25	150	25	31	40						
3232P1506		32	32	170	32	39	40							

DDPNN

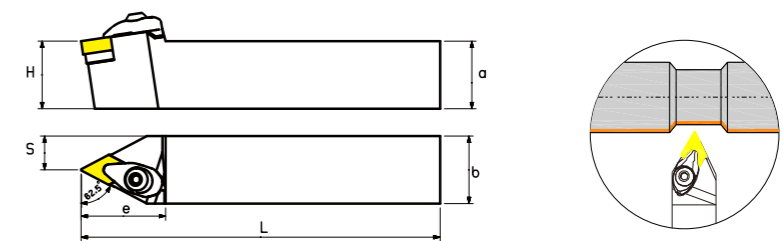

Type 型号	Dimension(mm) 基本尺寸							Applicable Inserts 使用的刀片	Shim 刀垫	Wrench 扳手	Clamp 压板	Clamp screw 压板螺丝	screw 螺钉	
	Stock 库存		a	b	L	h	s							e
	R	L												
DDPNN	2020K11		20	20	125	20	10	32	DN □□ 1104□□	MD 1103	S3	DCL2211	DM 0520	DSP 0510
	2525M11		25	25	150	25	12.5	36						
	2020K1504		20	20	125	20	10	36	DN□□ 1504□□	MD 1504	S4, S3	DCL2612	DM 0625	DSP 0612
	2525M1504		25	25	150	25	12.5	36						
	3232P1504		32	32	170	32	16	36						
	2020K1506		20	20	125	20	10	36	DN□□ 1506□□	MD 1504	S4, S3	DCL2612	DM 0625	DSP 0612
	2525M1506		25	25	150	25	12.5	36						
3232P1506		32	32	170	32	16	36							

了解具体库存情况请致电厂家 详情请登陆网站www.hnsant.com

车削刀具 | TURNING TOOLS



外圆车刀 External turning toolholders

DDQNR/L

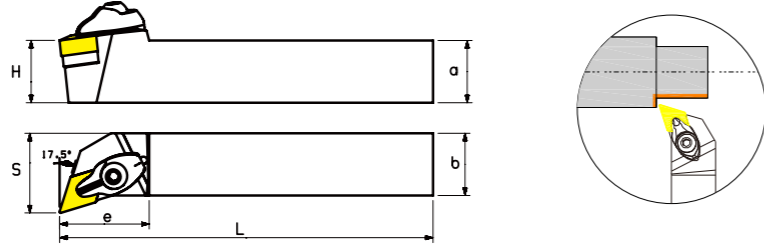

Type 型号	Dimension(mm) 基本尺寸							Applicable Inserts 使用的刀片	Shim 刀垫	Wrench 扳手	Clamp 压板	Clamp screw 压板螺丝	screw 螺钉	
	Stock 库存		a	b	L	h	s							e
	R	L												
DDQNR/L 2020K11			20	20	125	20	25	28	DN □□ 1104□□	MD 1103	S4, S3	DCL2211	DM 0520	DSP 0510
			25	25	150	25	31	28						
2020K1504			20	20	125	20	26	36	DN□□ 1504□□	MD 1504	S4, S3	DCL2612	DM 0625	DSP 0612
			25	25	150	25	32	36						
3232P1504			32	32	170	32	38	36						
2020K1506			20	20	125	20	26	36						
2525M1506			25	25	150	25	32	36						
3232P1506			32	32	170	32	38	36						

DSBNR/L

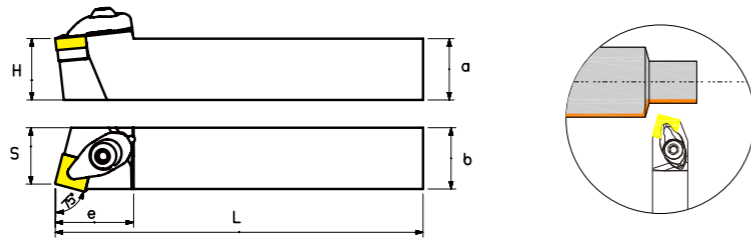

Type 型号	Dimension(mm) 基本尺寸							Applicable Inserts 使用的刀片	Shim 刀垫	Wrench 扳手	Clamp 压板	Clamp screw 压板螺丝	screw 螺钉	
	Stock 库存		a	b	L	h	s							e
	R	L												
DSBNR/L 2020K12			20	20	125	20	18	34	SN □□ 1204□□	MS 1204	S3,S4	DCL 2612	DM 0625	DSP 0612
			25	25	150	25	23	32						
3232P12			32	32	170	32	30	33						
2525M15			25	25	150	25	21	40						
3232P15			32	32	170	32	28	40						
3232P19			32	32	170	32	28	40						
4040R19			40	40	200	40	36	40						

了解具体库存情况请致电厂家 详情请登陆网站www.hnsant.com



车削刀具 | TURNING TOOLS

External turning toolholders 外圆车刀

DSDNN

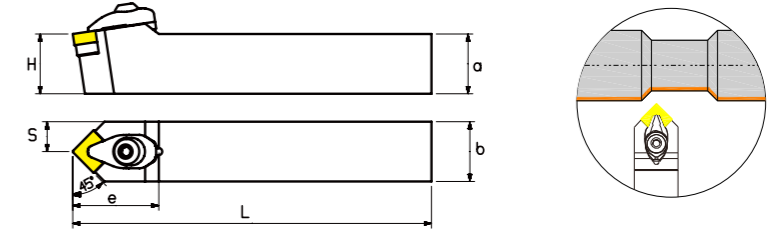

Type 型号	Dimension(mm) 基本尺寸							Applicable Inserts 使用的刀片	Shim 刀垫	Wrench 扳手	Clamp 压板	Clamp screw 压板螺丝	screw 螺钉	
	Stock 库存		a	b	L	h	s							e
	R	L												
DSDNN 2020K12			20	20	125	20	10	36	SN □□ 1204□□	MS 1204	S3,S4	DCL 2612	DM 0625	DSP 0612
			25	25	150	25	12.5	36						
3232P12			32	32	170	32	12.5	36						
2525M15			25	25	150	25	12.5	40						
3232P15			32	32	170	32	16	40						
3232P19			32	32	170	32	16	48						
4040R19			40	40	200	40	20	48						

DSSNR/L

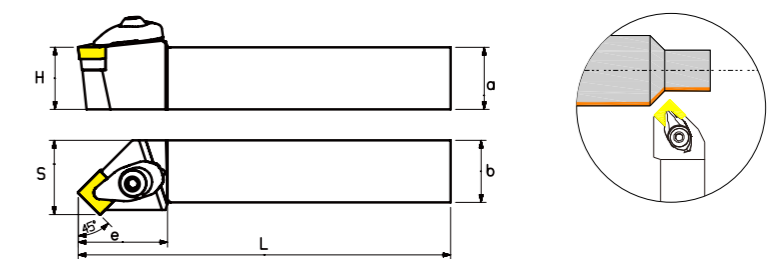

Type 型号	Dimension(mm) 基本尺寸							Applicable Inserts 使用的刀片	Shim 刀垫	Wrench 扳手	Clamp 压板	Clamp screw 压板螺丝	screw 螺钉	
	Stock 库存		a	b	L	h	s							e
	R	L												
DSSNR/L 2020K12			20	20	125	20	25	36	SN □□ 1204□□	MS 1204	S3,S4	DCL 2612	DM 0625	DSP 0612
			25	25	150	25	30	35						
3232P12			32	32	170	32	38	35						
2525M15			25	25	150	25	32	40						
3232P15			32	32	170	32	40	40						
3232P19			32	32	170	32	45	48						
4040R19			40	40	200	40	43	48						

了解具体库存情况请致电厂家 详情请登陆网站www.hnsant.com

车削刀具 | TURNING TOOLS



外圆车刀 External turning toolholders

DSKNR/L

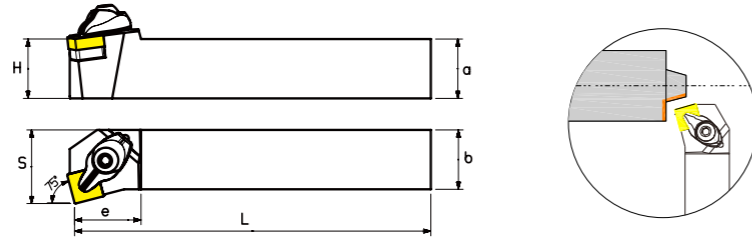

Type 型号	Dimension(mm) 基本尺寸							Applicable Inserts 使用的刀片	Shim 刀垫	Wrench 扳手	Clamp 压板	Clamp screw 压板螺丝	screw 螺钉	
	Stock 库存		a	b	L	h	s							e
	R	L												
DSKNR/L	2020K12		20	20	125	20	26	28	SN □□ 1204□□	MS 1204	S3,S4	DCL 2612	DM 0625	DSP 0612
	2525M12		25	25	150	25	36	28						
	3232P12		32	32	170	32	38	32						

DTGNR/L

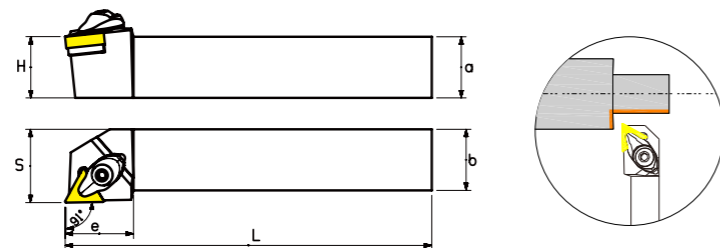

Type 型号	Dimension(mm) 基本尺寸							Applicable Inserts 使用的刀片	Shim 刀垫	Wrench 扳手	Clamp 压板	Clamp screw 压板螺丝	screw 螺钉	
	Stock 库存		a	b	L	h	s							e
	R	L												
DTGNR/L	2020K16		20	20	125	20	24	28	TN □□ 1604□□	MT 1603	S3	DCL 2211	DM 0520	DSP 0510
	2525M16		25	25	150	25	30	28						
	3225P16		32	25	170	32	30	28						
	3232P16		32	32	170	32	38	32						



车削刀具 | TURNING TOOLS

外圆车刀 External turning toolholders

DTFNR/L

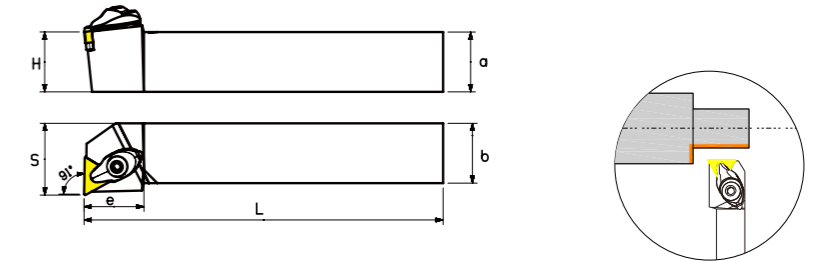

Type 型号	Dimension(mm) 基本尺寸							Applicable Inserts 使用的刀片	Shim 刀垫	Wrench 扳手	Clamp 压板	Clamp screw 压板螺丝	screw 螺钉	
	Stock 库存		a	b	L	h	s							e
	R	L												
DTFNR/L	2020K16		20	20	125	20	25	28	TN □□ 1604□□	MT 1603	S3	DCL 2211	DM 0520	DSP 0510
	2525M16		25	25	150	25	30	26						
	3225P16		32	25	170	32	30	26						
	3232P16		32	32	170	32	38	26						

DVVNN

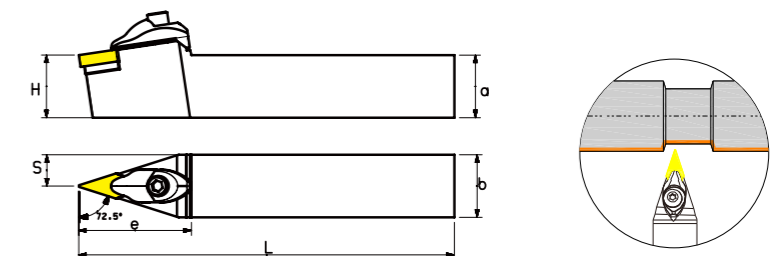

Type 型号	Dimension(mm) 基本尺寸							Applicable Inserts 使用的刀片	Shim 刀垫	Wrench 扳手	Clamp 压板	Clamp screw 压板螺丝	screw 螺钉	
	Stock 库存		a	b	L	h	s							e
	R	L												
DVVNN	2020K16		20	20	125	20	10	45	VN □□ 1604□□	MV 1603	S3	DCL 3113	M5X25 (内六角)	DSP 0510
	2525M16		25	25	150	25	12.5	45						
	3225P16		32	25	170	32	12.5	45						
	3232P16		32	32	170	32	16	45						

车削刀具 | TURNING TOOLS



外圆车刀 External turning toolholders

DVJNR/L

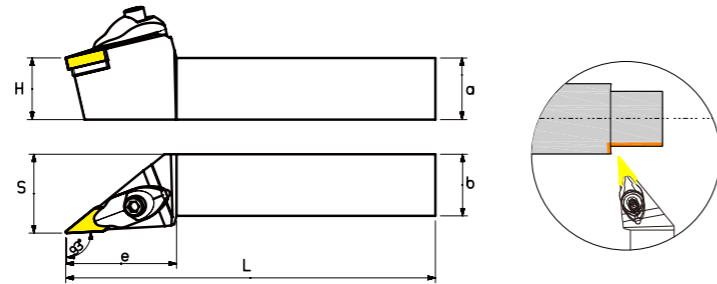

Type 型号	Dimension(mm) 基本尺寸							Applicable Inserts 使用的刀片	Shim 刀垫	Wrench 扳手	Clamp 压板	Clamp screw 压板螺丝	Screw 螺钉	
	Stock 库存	a	b	L	h	s	e							
DVJNR/L	2020K16		20	20	125	20	26	45	VN □ 1604□	MV 1603	S3,S4	DCL 3113	M5X25 (内六角)	DSP 0510
	2525M16		25	25	150	25	32	45						
	3225P16		32	25	170	32	32	45						
	3225P16		32	25	170	32	32	45						
	3232P16		32	32	170	32	40	45						

DWLNR/L

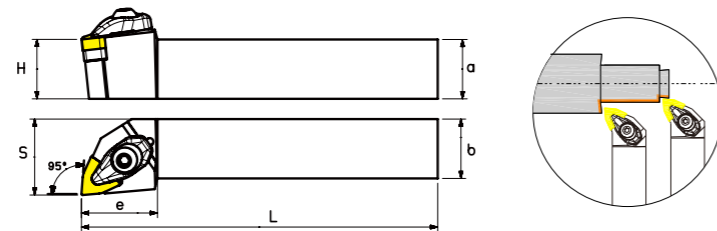

Type 型号	Dimension(mm) 基本尺寸							Applicable Inserts 使用的刀片	Shim 刀垫	Wrench 扳手	Clamp 压板	Clamp screw 压板螺丝	Screw 螺钉	
	Stock 库存	a	b	L	h	s	e							
DWLNR/L	2020K08		20	20	125	20	25	32	WN □ 0804□	MW 0804	S4 S3	DCL 2612	DM 0625	DSP 0612
	2525M08		25	25	150	25	32	31						
	3225P08		32	25	170	32	32	31						
	3232P08		32	32	170	32	39	31						
	2020K06		20	20	125	20	25	25						
2525M06		25	25	150	25	30	25	WN □ 0603□	MW 0603	S3	DCL 2211	DM 0520	DSP 0510	



车削刀具 | TURNING TOOLS

外圆车刀 External turning toolholders 高压内冷外圆车刀

DCLNR/L-P

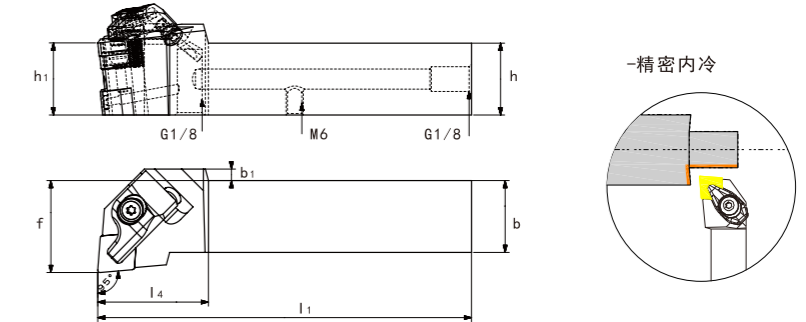
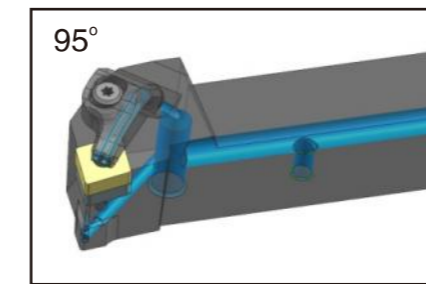

Type 型号	Dimension(mm) 基本尺寸							Applicable Inserts 使用的刀片	Shim 刀垫	Clamp 压板	Clamp screw 压板螺丝	Screw 刀垫螺钉	Spring 弹簧	Wrench 扳手	Thread Plug 螺纹塞
	h=h1	b	b1	f	L1	L4									
DCLNR/L	2020X12-P	20	20	10	25	115	38.5	CN □ 1204□	DC12476	PK265R/L	5412-M521	L60 M4X10	φ7	T15	G1/8
	2525X12-P	25	25	4	32	130	38.5								
	2525X16-P	25	25	12	32	135	43.5								
	3232X16-P	32	32	6	40	147	43.5								

DDJNR/L-P

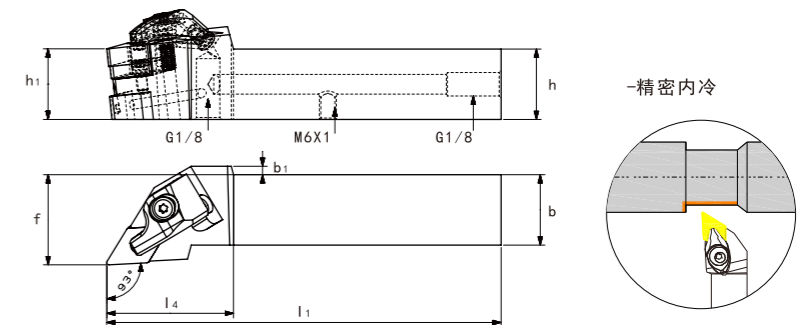
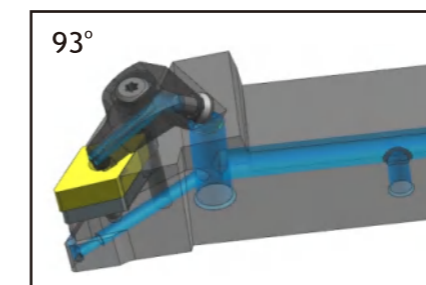

Type 型号	Dimension(mm) 基本尺寸							Applicable Inserts 使用的刀片	Shim 刀垫	Clamp 压板	Clamp screw 压板螺丝	Screw 刀垫螺钉	Spring 弹簧	Wrench 扳手	Thread Plug 螺纹塞
	h=h1	b	b1	f	L1	L4									
DDJNR/L	2020X15-P	20	20	7	25	125	45	DN □ 1506□	DD15476	PK265R/L	5412-M521	L60 M4X10	φ7	T15	G1/8
	2525X15-P	25	25	3	32	140	45								

车削刀具 | TURNING TOOLS



高压内冷外圆车刀 External turning toolholders 外圆车刀

DSBNR/L-P

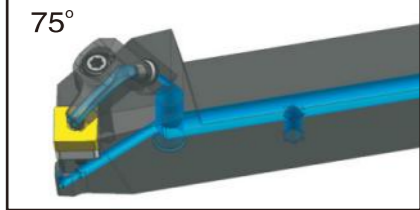

75°

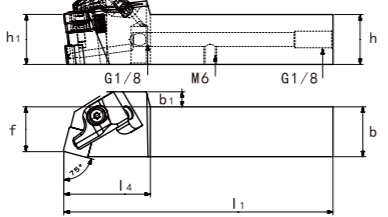

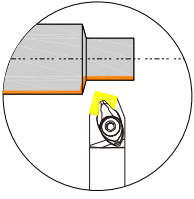

-精密内冷

Type 型号	Dimension(mm) 基本尺寸						Applicable Inserts 使用的刀片	Shim 刀垫	Clamp 压板	Clamp screw 压板螺丝	Screw 刀垫螺钉	弹簧	Wrench 扳手	螺纹塞
	h=h1	b	b1	f	L1	L4								
DSBNR/L 2525X12-P	25	25	7	22	135	43.5	SN □□ 1204□□	DS12476	PK265R/L	5412-M521	L60 M4X10	φ7	T15	G1/8

DVJNR/L-P

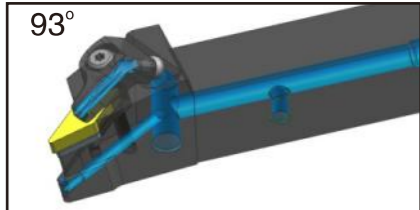

93°

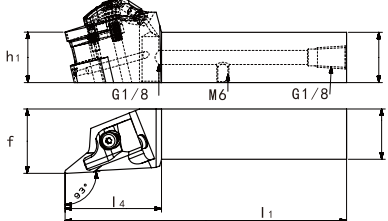

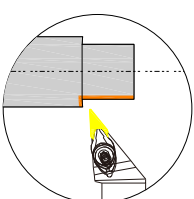

-精密内冷

Type 型号	Dimension(mm) 基本尺寸						Applicable Inserts 使用的刀片	Shim 刀垫	Clamp 压板	Clamp screw 压板螺丝	Screw 刀垫螺钉	弹簧	Wrench 扳手	螺纹塞
	h=h1	b	b1	f	L1	L4								
DVJNR/L 2020X16-P	20	20	4	25	125	48.5	VN □□ 1604□□	DV16320	PK261R/L	5412-M521	L60 M4X10	φ7	T15	G1/8
DVJNR/L 2525X16-P	25	25	0	32	140	48								

DWLNR/L-P

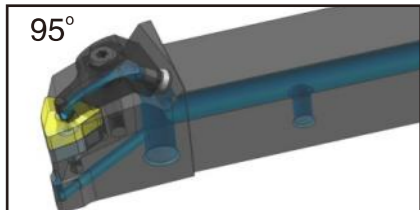

95°

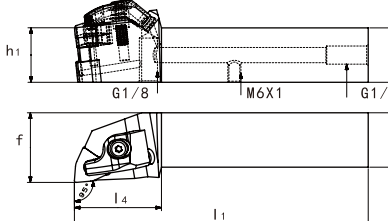

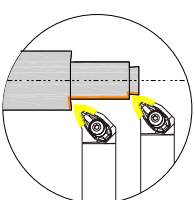

-精密内冷

Type 型号	Dimension(mm) 基本尺寸						Applicable Inserts 使用的刀片	Shim 刀垫	Clamp 压板	Clamp screw 压板螺丝	Screw 刀垫螺钉	弹簧	Wrench 扳手	螺纹塞
	h=h1	b	b1	f	L1	L4								
DWLNR/L 2020X08-P	20	20	0	25	120	40	WN □□ 0804□□	DW08476	PK266R/L	5412-M521	L60 M4X10	φ7	T15	G1/8
DWLNR/L 2525X08-P	25	25	0	32	135	40								



车削刀具 | TURNING TOOLS

External turning toolholders 外圆车刀

WTQNR/L



105°

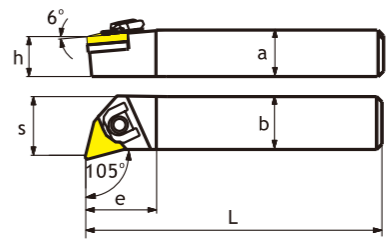

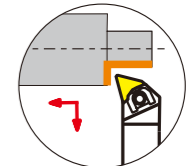

Type 型号	Dimension(mm) 基本尺寸							Applicable Inserts 使用的刀片	Clamping screw 螺钉	Shim 刀垫	Wrench 扳手	Clamp 压板	Clamping stud 中心柱	
	Stock 库存		a	b	L	h	s							e
	R	L												
WTQNR/L 2020K16			20	20	125	20	30	27	TN □□ 1604□□	WM0525	MT 1603	S2.5 S4	WTL16	SZ 0515
			25	25	150	25	35	27						
			32	32	170	32	45	32						
WTQNR/L 2525M22			25	25	150	25	38	36	TN □□ 2204□□		MT 2204	S3,S4	WTL 22	SZ 0618
			32	32	170	32	45	36						

WTJNR/L



93°

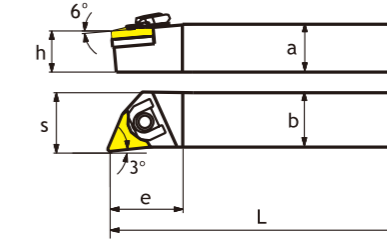

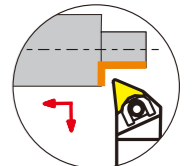

Type 型号	Dimension(mm) 基本尺寸							Applicable Inserts 使用的刀片	Clamping screw 螺钉	Shim 刀垫	Wrench 扳手	Clamp 压板	Clamping stud 中心柱	
	Stock 库存		a	b	L	h	s							e
	R	L												
WTJNR/L 1316H16			13	16	100	31	20	20	TN □□ 1604□□	WM0525	MT 1603	S2.5 S4	WTL16	SZ 0515
			16	16	100	31	22	32						
			20	20	125	31	25	32						
			32	32	170	31	39	36						
			25	25	150	31	32	32						
WTJNR/L 2525M22			25	25	150	25	32	38	TN □□ 2204□□		MT 2204	S3,S4	WTL 22	SZ 0618
			32	32	170	32	39	38						
			32	32	170	32	39	38						

车削刀具 | TURNING TOOLS



外圆车刀 External turning toolholders

WTENN

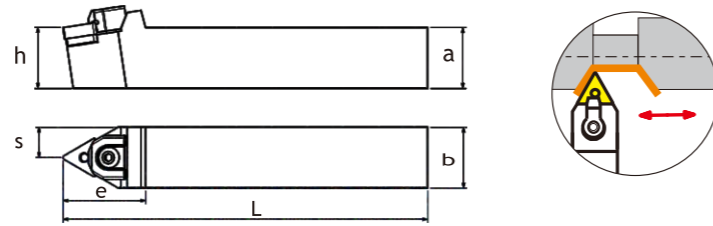

Type 型号	Dimension(mm) 基本尺寸							Applicable Inserts 使用的刀片	Clamping screw 螺钉	Shim 刀垫	Wrench 扳手	Clamp 压板	Clamping stud 中心柱	
	Stock 库存		a	b	L	h	s							e
	R	L												
WTENN	2020K16		20	20	125	20	10	34	TN□□ 1604□□	WM0525	MT 1603	S2.5 S4	WTL16	SZ 0515
	2525M16		25	25	150	25	12.5	33						
	3232P16		32	32	170	32	16	33						
	2525M22		25	25	150	25	12.5	33						
	3232P22		32	32	170	32	16	33						
								TN□□ 2204□□		MT 2204	S3,S4	WTL22	SZ 0618	

WWLNR/L

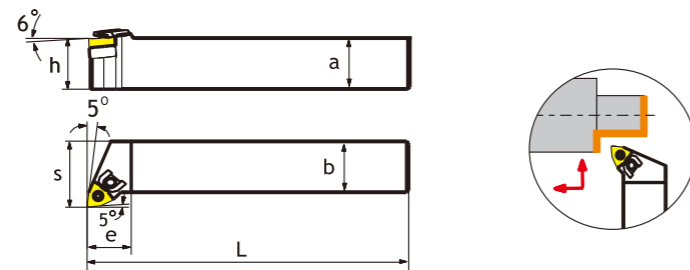

Type 型号	Dimension(mm) 基本尺寸							Applicable Inserts 使用的刀片	Clamping screw 螺钉	Shim 刀垫	Wrench 扳手	Clamp 压板	Clamping stud 中心柱	
	Stock 库存		a	b	L	h	s							e
	R	L												
WWLNR/L	2020K08		20	20	125	25	27	32	WN□□ 0804□□	WM0525	MW 0804	S3 S4	WWL08	SZ 0618
	2525M08		25	25	150	32	32	32						
	3232P08		32	32	170	40	38	32						

★ 电话查询库存

了解具体库存情况请致电厂家 详情请登陆网站www.hnsant.com

车削刀具 | TURNING TOOLS



内孔车刀 Internal turning toolholders 内孔车刀

记号 Symbol	A	E	C	S	X
刀杆类型 Type of shank	钢杆+油冷却孔 Steel Shank+ Oil Cooling Hole	硬质合金杆 +油冷却孔 Carbide Shank+ Oil Cooling Hole	硬质合金杆 Carbide Shank	钢杆 Steel Shank	使用特殊刀片 Special Insert Application

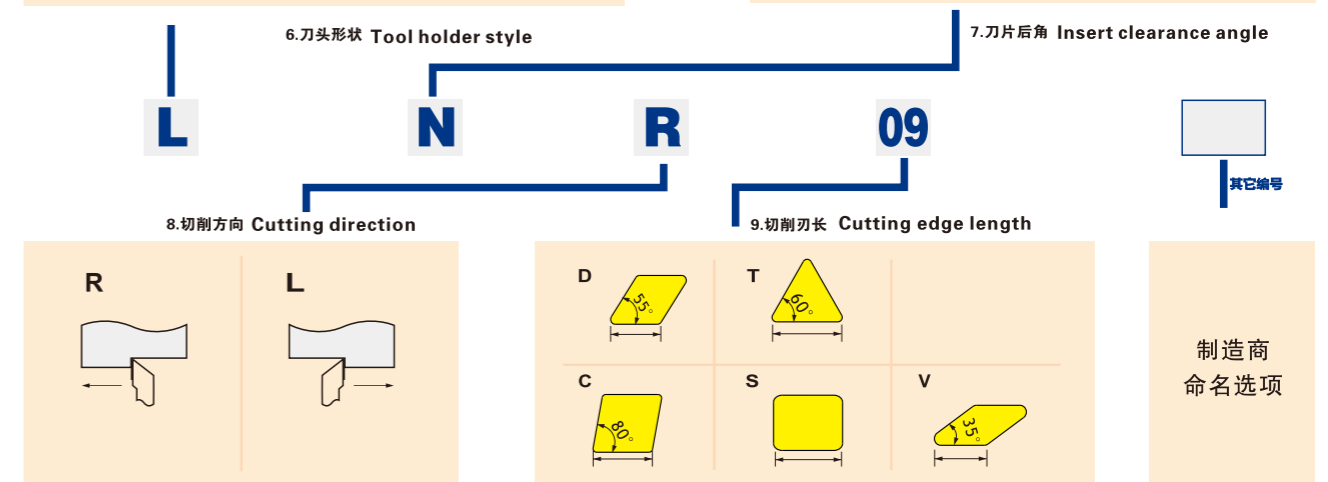
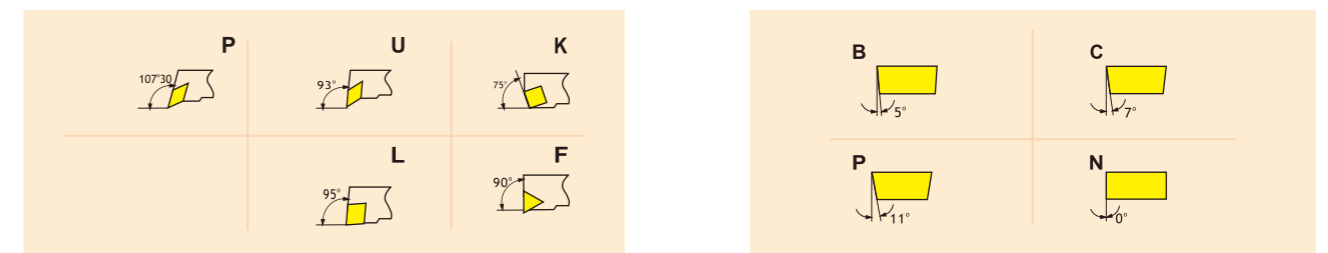
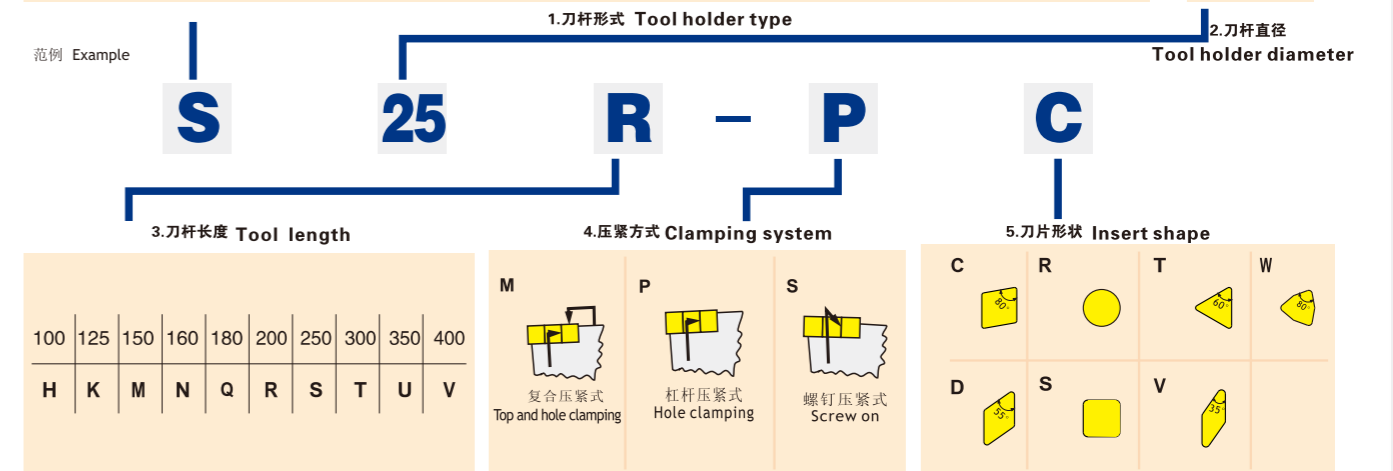

了解具体库存情况请致电厂家 详情请登陆网站www.hnsant.com

车削刀具 | TURNING TOOLS



内孔车刀 Internal turning toolholders

MCKNR/L

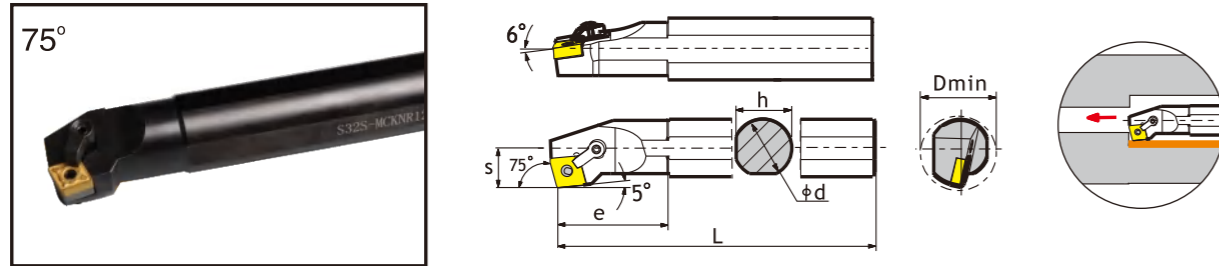

Type 型号	Dimension(mm) 基本尺寸							Applicable Inserts 使用的刀片	Shim 刀垫	Clamping stud 销钉	Clamp 压板	Clamping screw 双头螺钉	Wrench 扳手	
	Stock 库存		Dmin	φd	h	L	s							e
	R	L												
S20Q-MCKNR/L12			26	20	18	180	14	35	CN □ 1204 □	X	MSP 613	MCL1810	WS 061020	S2.5,S3
S25R-MCKNR/L12			32	25	23	200	16.5	35						
S32S-MCKNR/L12			40	32	30	250	22	50		MC 1204	MSP617	MCL1814	WS 061025	S3
S40T-MCKNR/L12			50	40	38	300	26	55						
S50U-MCKNR/L12			60	50	48	350	30	60						

MCLNR/L

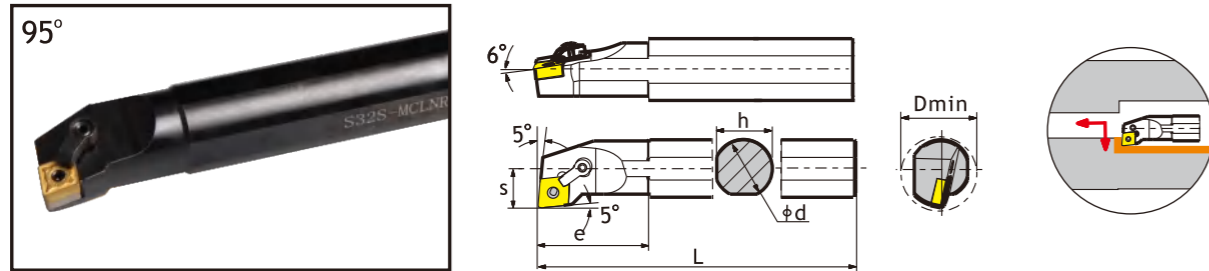

Type 型号	Dimension(mm) 基本尺寸							Applicable Inserts 使用的刀片	Shim 刀垫	Clamping stud 销钉	Clamp 压板	Clamping screw 双头螺钉	Wrench 扳手	
	Stock 库存		Dmin	φd	h	L	s							e
	R	L												
S20Q-MCLNR/L12			26	20	18	180	13	40	CN □ 1204 □	X	MSP 613	MCL1810	WS 061020	S2.5,S3
S25R-MCLNR/L12			32	25	23	200	16	40						
S32S-MCLNR/L12			40	32	30	250	20	50		MC 1204	MSP617	MCL1814	WS 061025	S3
S40T-MCLNR/L12			50	40	37	300	26	55						
S50U-MCLNR/L12			60	50	46	350	31	70						



车削刀具 | TURNING TOOLS

内孔车刀 Internal turning toolholders

MDQNR/L

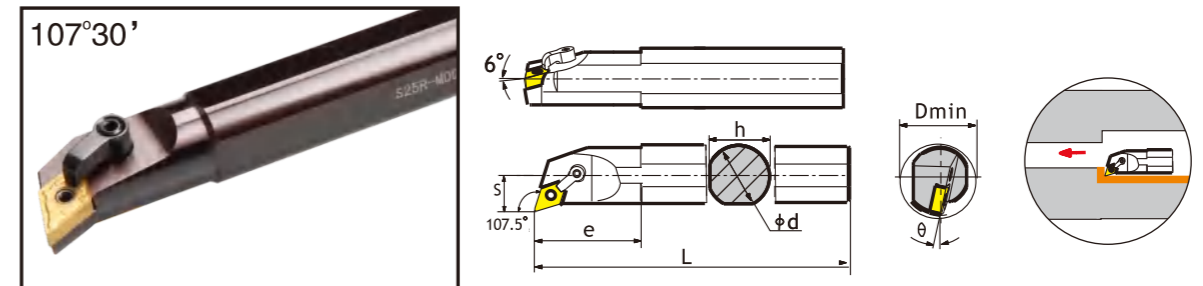

Type 型号	Dimension(mm) 基本尺寸							Applicable Inserts 使用的刀片	Shim 刀垫	Clamping stud 销钉	Clamp 压板	Clamping screw 双头螺钉	Wrench 扳手	
	Stock 库存		Dmin	φd	h	L	s							e
	R	L												
S20Q-MDQNR/L1504			26	20	18	180	13	40	DN □ 1504 □	X	MSP613	MCL1810	WS 061020	S2.5,S3
S25R-MDQNR/L1504			32	25	23	200	17	45						
S32S-MDQNR/L1504			40	32	30	250	20	55		MD1504	MSP617	MCL2114	WS061025	S3
S40T-MDQNR/L1504			50	40	38	300	24	55						
S32S-MDQNR/L1506			40	32	30	250	20	55						
S40T-MDQNR/L1506			50	40	38	300	24	55	DN □ 1506 □	MSP619				

MDUNR/L

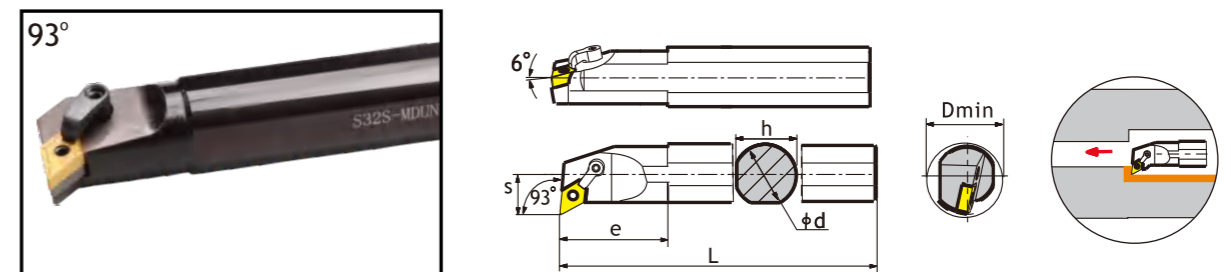

Type 型号	Dimension(mm) 基本尺寸							Applicable Inserts 使用的刀片	Shim 刀垫	Clamping stud 销钉	Clamp 压板	Clamping screw 双头螺钉	Wrench 扳手	
	Stock 库存		Dmin	φd	h	L	s							e
	R	L												
S20Q-MDUNR/L1504			28	20	18	180	17	40	DN □ 1504 □	X	MSP613	MCL1810	WS 061020	S2.5,S3
S25R-MDUNR/L1504			32	25	24	200	19	40						
S32S-MDUNR/L1504			40	32	30	250	22	45		MD1504	MSP617	MCL1814	WS061025	S3
S40T-MDUNR/L1504			50	40	37	300	26	55						
S32S-MDUNR/L1506			40	32	30	250	22	45						
S40T-MDUNR/L1506			50	40	37	300	26	55						

车削刀具 | TURNING TOOLS



内孔车刀 Internal turning toolholders

MDZNR/L

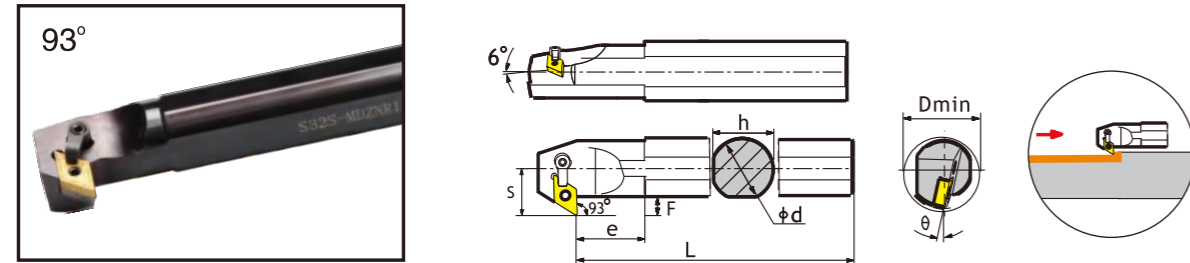

Type 型号	Dimension(mm) 基本尺寸								Applicable Inserts 使用的刀片	Shim 刀垫	Clamping stud 销钉	Clamp 压板	Clamping screw 双头螺钉	Wrench 扳手		
	Stock 库存	R	L	Dmin	φd	h	L	s							e	F
S25R-MDZNR/L1504				36	25	23	200	22	35	11	DN□□ 1504□□	X	MSP613	MCL1814	WS061025	S2.5,S3
S32S-MDZNR/L1504				43	32	30	250	26	40	12						
S40T-MDZNR/L1504				50	40	37	300	29	50	11.5						
S32S-MDZNR/L1506				43	32	30	250	26	40	12						
S40T-MDZNR/L1506				50	40	37	300	29	50	11.5						
											MD1504	MSP617				S3
											DN□□ 1506□□	MSP619				

MSKNR/L

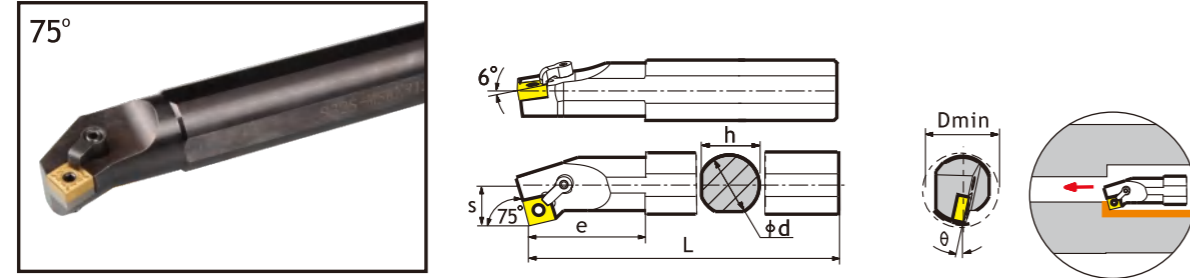

Type 型号	Dimension(mm) 基本尺寸								Applicable Inserts 使用的刀片	Shim 刀垫	Clamping stud 销钉	Clamp 压板	Clamping screw 双头螺钉	Wrench 扳手		
	Stock 库存	R	L	Dmin	φd	h	L	s							e	F
S20Q-MSKNR/L12				26	20	18	180	13	15°	31	SN□□ 1204□□	X	MSP613	MCL1810	WS061020	S2.5,S3
S25R-MSKNR/L12				32	25	23	200	17	12°	35						
S32S-MSKNR/L12				40	32	30	250	22	17°	40						
S40T-MSKNR/L12				50	40	37	300	27	15°	50						



车削刀具 | TURNING TOOLS

内孔车刀 Internal turning toolholders

MVQNR/L

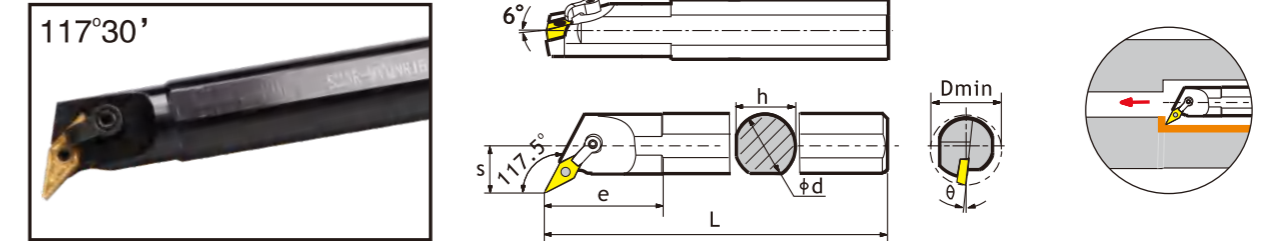

Type 型号	Dimension(mm) 基本尺寸								Applicable Inserts 使用的刀片	Shim 刀垫	Clamping stud 销钉	Clamp 压板	Clamping screw 双头螺钉	Wrench 扳手			
	Stock 库存	R	L	Dmin	φd	h	L	s							e	F	
S25R-MVQNR/L16				32	25	23	200	17	12°	40	VN□□ 1604□□	X	MSP510	MCL1814	WS061025	S2,S3	
S32S-MVQNR/L16				42	32	30	250	22	17°	40							
S40T-MVQNR/L16				50	40	37	300	27	15°	50							

MVUNR/L

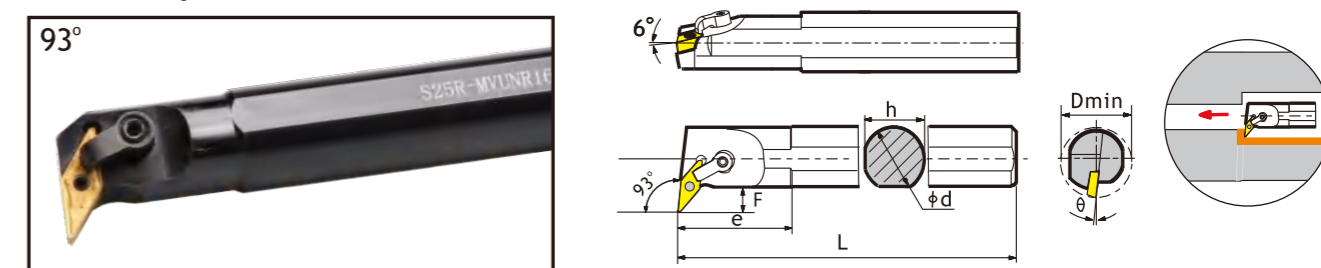

Type 型号	Dimension(mm) 基本尺寸								Applicable Inserts 使用的刀片	Shim 刀垫	Clamping stud 销钉	Clamp 压板	Clamping screw 双头螺钉	Wrench 扳手			
	Stock 库存	R	L	Dmin	φd	h	L	s							e	F	
S25R-MVUNR/L16				36	25	23	200	20	40	8	VN□□ 1604□□	X	MSP510	MCL1814	WS061025	S2,S3	
S32S-MVUNR/L16				42	32	30	250	23	40	8							
S40T-MVUNR/L16				50	40	37	300	27	55	10							

车削刀具 | TURNING TOOLS



内孔车刀 Internal turning toolholders

MVWNR/L

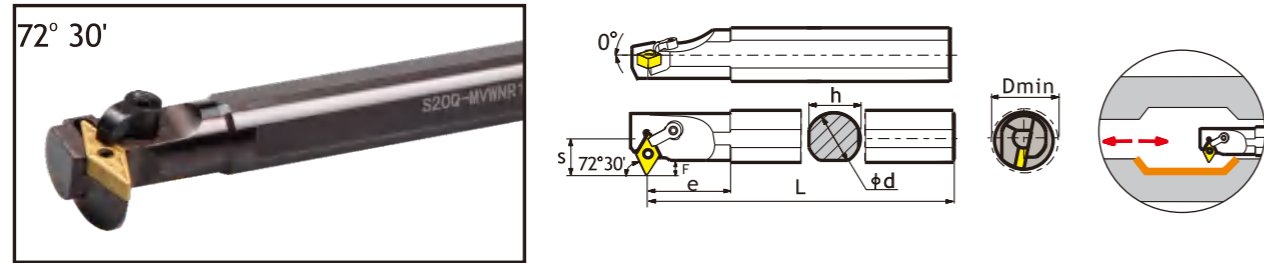

Type 型号	Dimension(mm) 基本尺寸							Applicable Inserts 使用的刀片	Shim 刀垫	Clamping stud 销钉	Clamp 压板	Clamping screw 双头螺钉	Wrench 扳手		
	Stock 库存		Dmin	φd	h	L	s							e	F
	R	L													
S25R-MVWNR/L16			36	25	23	200	22	35	10	VN□□ 1604□□	X	MSP510	MCL1814	WS061025	S2,S3
S32S-MVWNR/L16			48	32	30	250	25	40	10		MV 1603	MSP513			
S40T-MVWNR/L16			56	40	37	300	29	45	11						

MVXNR/L

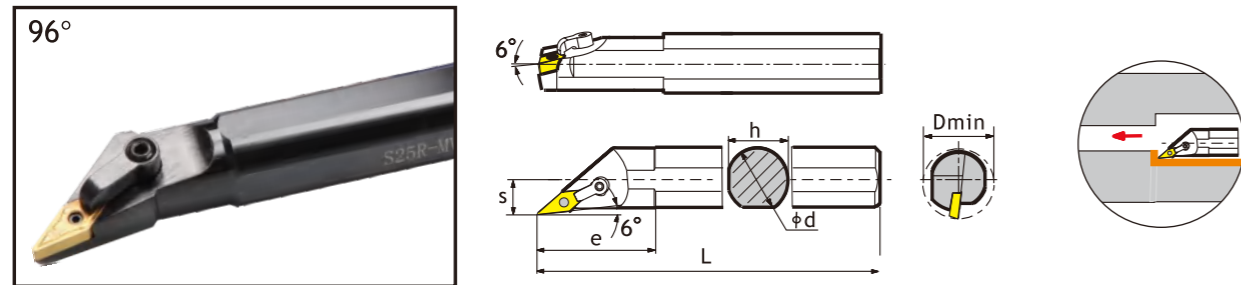

Type 型号	Dimension(mm) 基本尺寸							Applicable Inserts 使用的刀片	Shim 刀垫	Clamping stud 销钉	Clamp 压板	Clamping screw 双头螺钉	Wrench 扳手	
	Stock 库存		Dmin	φd	h	L	s							e
	R	L												
S25R-MVXNR/L16			32	25	23	200	17	55	VN□□ 1604□□	X	MSP510	MCL2414	WS061025	S2,S3
S32S-MVXNR/L16			42	32	30	250	21	60		MV 1603	MSP513			
S40T-MVXNR/L16			50	40	38	300	25	68						



车削刀具 | TURNING TOOLS

Internal turning toolholders 内孔车刀

MWLNR/L

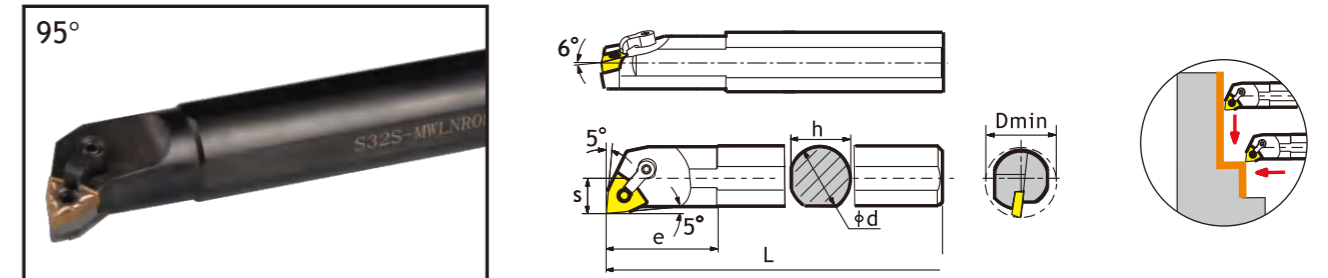

Type 型号	Dimension(mm) 基本尺寸							Applicable Inserts 使用的刀片	Shim 刀垫	Clamping stud 销钉	Clamp 压板	Clamping screw 双头螺钉	Wrench 扳手	
	Stock 库存		Dmin	φd	h	L	s							e
	R	L												
S20Q-MWLNR/L08			25	20	18	180	14.5	36	WN□□ 0804□□	X	MSP613	MCL1810	WS061020	S2.5,S3
S25R-MWLNR/L08			32	25	23	200	17	40		MW 0804	MSP617	MCL1814	WS061025	S3
S32S-MWLNR/L08			41	32	30	250	22	50						
S40T-MWLNR/L08			50	40	37	300	27	55						

MTFNR/L

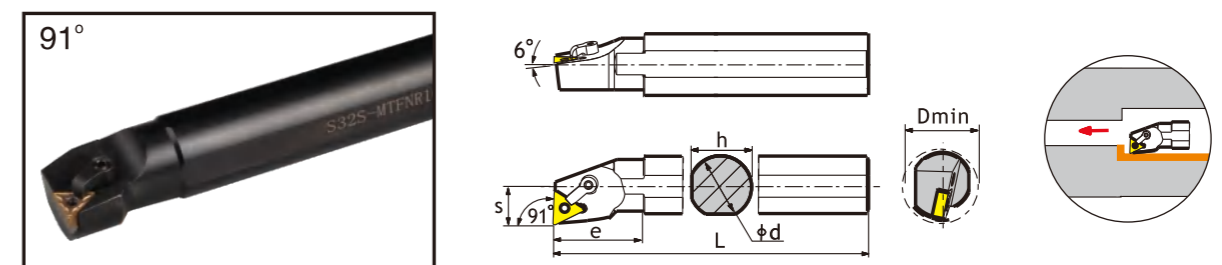

Type 型号	Dimension(mm) 基本尺寸							Applicable Inserts 使用的刀片	Shim 刀垫	Clamping stud 销钉	Clamp 压板	Clamping screw 双头螺钉	Wrench 扳手	
	Stock 库存		Dmin	φd	h	L	s							e
	R	L												
S20Q-MTFNR/L16			25	20	18	180	13	35	TN□□ 1604□□	X	MSP510	MCL1810	WS061020	S2,S3
S25R-MTFNR/L16			32	25	23	200	16	40		MT 1603	MSP513	MCL1814	WS061025	
S32S-MTFNR/L16			40	32	30	250	20	45						
S40T-MTFNR/L16			50	40	37	300	25	50						

车削刀具 | TURNING TOOLS



内孔车刀 Internal turning toolholders

MTQNR/L

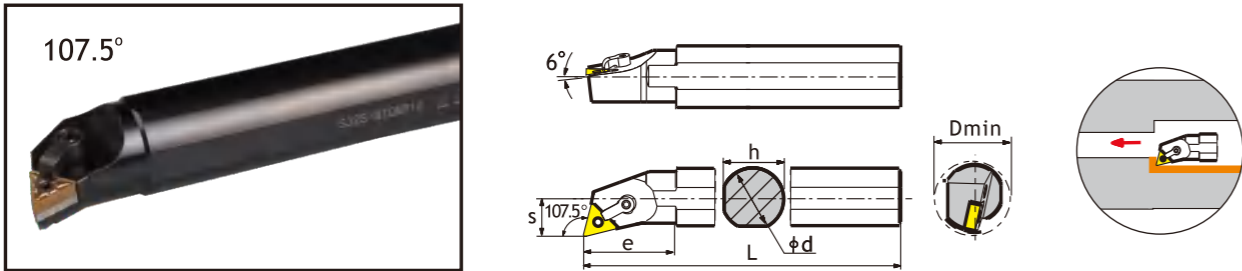

Type 型号	Dimension(mm) 基本尺寸							Applicable Inserts 使用的刀片	Shim 刀垫	Clamping stud 销钉	Clamp 压板	Clamping screw 双头螺钉	Wrench 扳手	
	Stock 库存		Dmin	phi d	h	L	s							e
	R	L												
S20Q-MTQNR/L16			25	20	18	180	14	35	TN□□ 1604□□	X	MSP510	MCL1810	WS061020	S2,S3
S25R-MTQNR/L16			32	25	23	200	18	35						
S32S-MTQNR/L16			40	32	30	250	21	40		MT 1603	MSP513	MCL1814	WS061025	
S40T-MTQNR/L16			50	40	37	300	25	50						

MTJNR/L

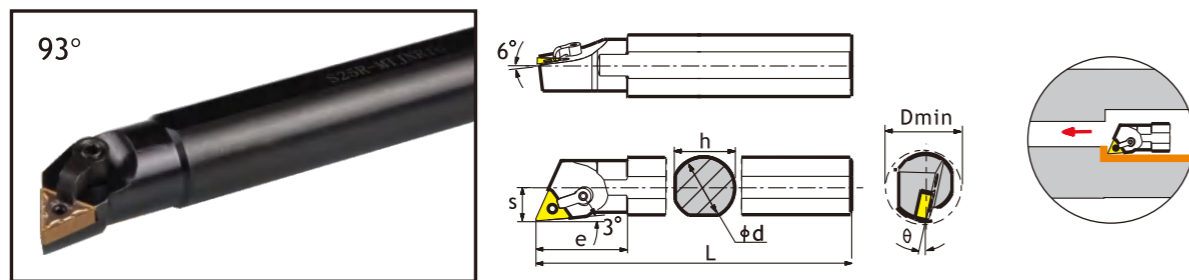

Type 型号	Dimension(mm) 基本尺寸							Applicable Inserts 使用的刀片	Shim 刀垫	Clamping stud 销钉	Clamp 压板	Clamping screw 双头螺钉	Wrench 扳手	
	Stock 库存		Dmin	phi d	h	L	s							e
	R	L												
S25R-MTJNR/L16			32	25	23	200	15	40	TN□□ 1604□□	X	MSP510			S2,S3
S32S-MTJNR/L16			40	32	30	250	18	45						
S40T-MTJNR/L16			50	40	37	300	24	55		MT 1603	MSP513	MCL1814	WS061025	

了解具体库存情况请致电厂家 详情请登陆网站www.hnsant.com

车削刀具 | TURNING TOOLS



内孔车刀 Internal turning toolholders

MTUNR/L

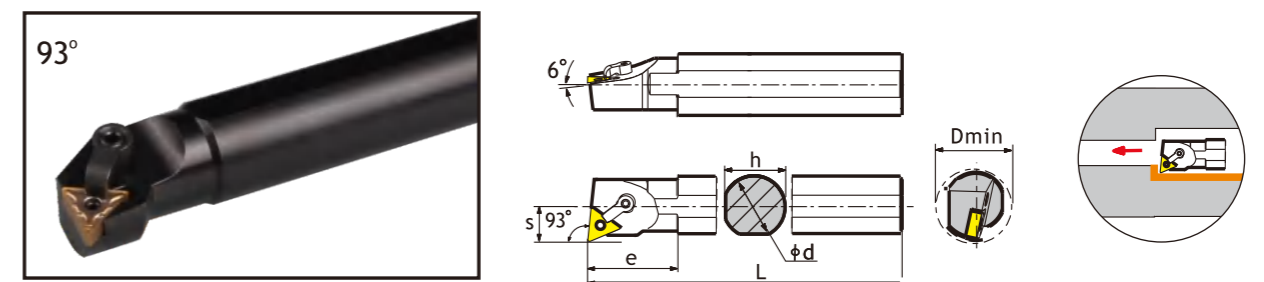

Type 型号	Dimension(mm) 基本尺寸							Applicable Inserts 使用的刀片	Shim 刀垫	Clamping stud 销钉	Clamp 压板	Clamping screw 双头螺钉	Wrench 扳手	
	Stock 库存		Dmin	phi d	h	L	s							e
	R	L												
S20Q-MTUNR/L16			25	20	18	180	13	31	TN□□ 1604□□	X	MSP510	MCL1810	WS061020	S2,S3
S25R-MTUNR/L16			32	25	23	200	17	35						
S32S-MTUNR/L16			40	32	30	250	22	40		MT 1603	MSP513	MCL1814	WS061025	
S40T-MTUNR/L16			50	40	37	300	23	50						

MTWNR/L

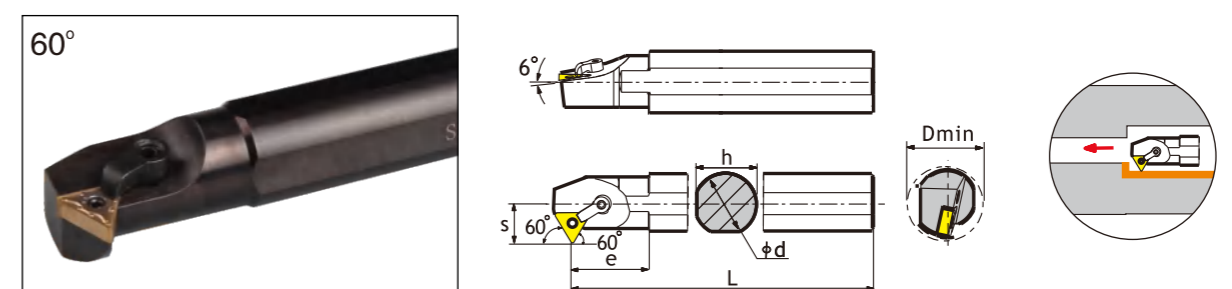

Type 型号	Dimension(mm) 基本尺寸							Applicable Inserts 使用的刀片	Shim 刀垫	Clamping stud 销钉	Clamp 压板	Clamping screw 双头螺钉	Wrench 扳手	
	Stock 库存		Dmin	phi d	h	L	s							e
	R	L												
S20Q-MTWNR/L16			27	20	18	180	15	31	TN□□ 1604□□	X	MSP510	MCL1810	WS061020	S2,S3
S25R-MTWNR/L16			32	25	23	200	17	35						
S32S-MTWNR/L16			40	32	30	250	22	42		MT 1603	MSP513	MCL1814	WS061025	
S40T-MTWNR/L16			50	40	38	300	27	50						

了解具体库存情况请致电厂家 详情请登陆网站www.hnsant.com

车削刀具 | TURNING TOOLS



内孔车刀 Internal turning toolholders

PCLNR/L

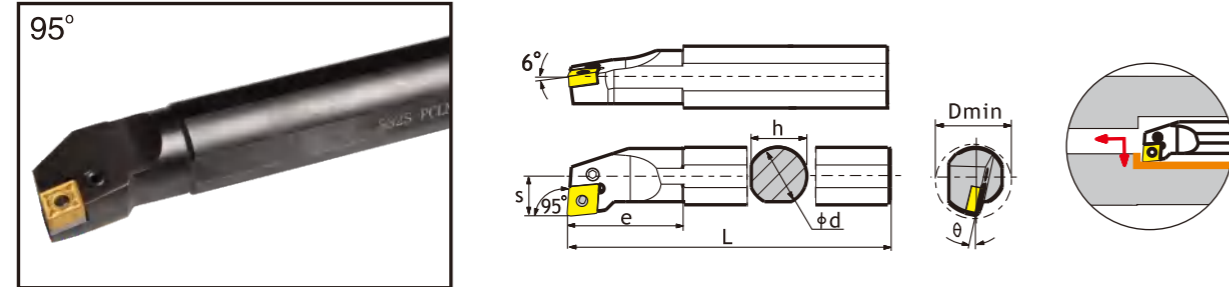

Type 型号	Dimension(mm) 基本尺寸								Applicable Inserts 使用的刀片	Screw 螺钉	Wrench 扳手	Lever 杠杆	Shim 刀垫	Shim pin 垫档	
	Stock 库存		Dmin	φd	h	L	s	θ							e
	R	L													
S16Q-PCLNR/L09			20	16	15	180	10	-12°	30	CN□ 0903□	VHX0509	S2	LV3C	-	-
S20Q-PCLNR/L09			25	20	18	180	12	-11°	30						
S25R-PCLNR/L09			32	25	23	200	15	-10°	35						
S20Q-PCLNR/L12			25	20	18	180	13	-11°	35						
S25R-PCLNR/L12			32	25	23	200	15	12°	40						
S32S-PCLNR/L12			44	32	30	250	22	-10°	50						
S40T-PCLNR/L12			54	40	37	300	24	-10°	55						
S50U-PCLNR/L12			63	50	47	350	27	-10°	58						
S50U-PCLNR/L19			63	50	47	350	32	-10°	70						
											VHX0821	S3	LV4	PC12318	SP4
											VHX1027	S4	LV6	PC19476	SP6

PDSNR/L

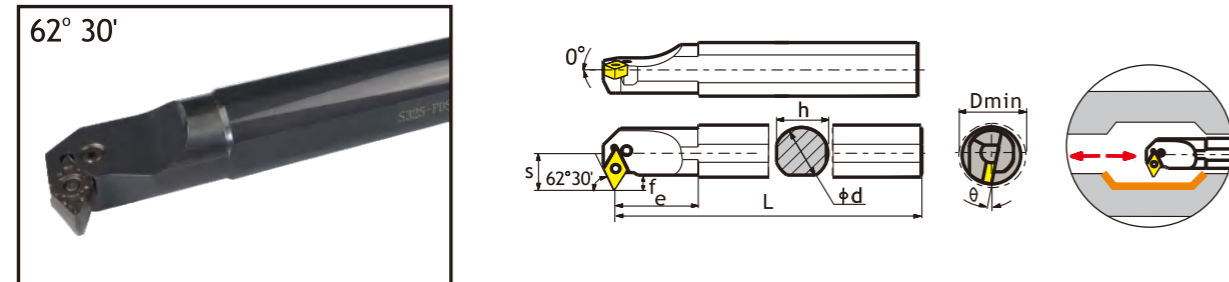

Type 型号	Dimension(mm) 基本尺寸									Applicable Inserts 使用的刀片	Screw 螺钉	Wrench 扳手	Lever 杠杆	Shim 刀垫	Shim pin 垫档
	Stock 库存		Dmin	φd	h	L	s	e	f						
	R	L													
S32S-PDSNR/L15			40	32	30	250	23.5	45	9	DN□ 1506□	VHX0821	S3	LV4B	PD15318	SP4
S40T-PDSNR/L15			50	40	37	300	28.5	43	11						
S32S-PDSNR/L15-3			40	32	30	250	23.5	45	9						
S40T-PDSNR/L15-3			50	40	37	300	28.5	43	11						
										DN□ 1504□	VHX0821	S3	LV4	PD15318	SP4

了解具体库存情况请致电厂家 详情请登陆网站www.hnsant.com



车削刀具 | TURNING TOOLS

Internal turning toolholders 内孔车刀

PDUNR/L

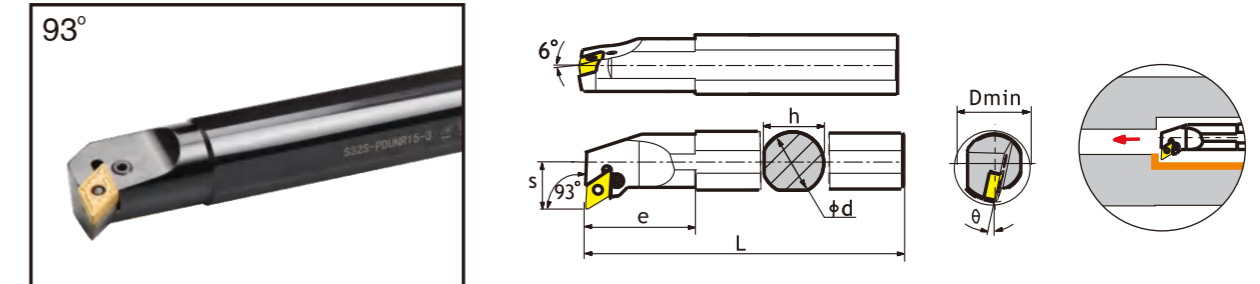

Type 型号	Dimension(mm) 基本尺寸								Applicable Inserts 使用的刀片	Screw 螺钉	Wrench 扳手	Lever 杠杆	Shim 刀垫	Shim pin 垫档	
	Stock 库存		Dmin	φd	h	L	s	θ							e
	R	L													
S20Q-PDUNR/L 11			25	20	18	180	13	-16°	30	DN□ 1104□	VHX0512	S2	LV3D	-	-
S25R-PDUNR/L 11			32	25	23	200	17	-13°	35						
S32S-PDUNR/L 11			40	32	30	250	22	-16°	40	DN□ 1506□	VHX0821	S3	LV4B	PD15318	SP4
S32S-PDUNR/L 15			40	32	30	250	22	-16°	50						
S40T-PDUNR/L 15			50	40	37	300	27	-11°	50						
S32S-PDUNR/L 15-3			40	32	30	250	22	-16°	50						
S40T-PDUNR/L 15-3			50	40	37	300	27	-11°	50	DN□ 1504□	VHX0821	S3	LV4	PD15318	SP4

PSKNR/L

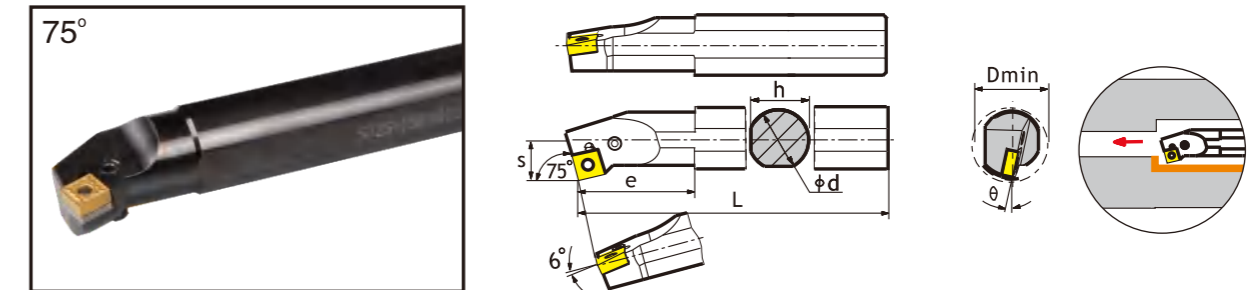

Type 型号	Dimension(mm) 基本尺寸								Applicable Inserts 使用的刀片	Screw 螺钉	Wrench 扳手	Lever 杠杆	Shim 刀垫	Shim pin 垫档	
	Stock 库存		Dmin	φd	h	L	s	θ							e
	R	L													
S25R-PSKNR/L 12			32	25	23	200	17	-12°	42	SN□ 1204□	VHX0613	S2.5	LV4A	-	-
S32S-PSKNR/L 12			44	32	30	250	22	-10°	45						
S40T-PSKNR/L 12			54	40	37	300	27	-10°	50		VHX0821	S3	LV4	PS12318	SP4

了解具体库存情况请致电厂家 详情请登陆网站www.hnsant.com

车削刀具 | TURNING TOOLS



内孔车刀 Internal turning toolholders

PTFNR/L

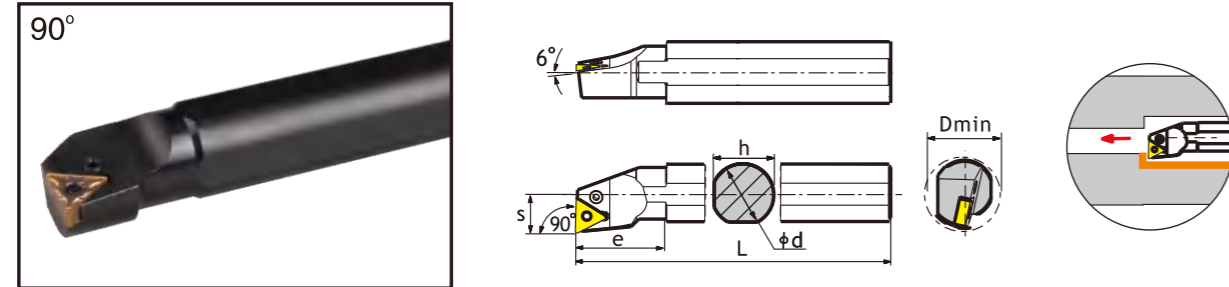

Type 型号	Dimension(mm) 基本尺寸								Applicable Inserts 使用的刀片	Screw 螺钉	Wrench 扳手	Lever 杠杆	Shim 刀垫	Shim pin 垫档
	Stock 库存		Dmin	φd	h	L	s	e						
	R	L												
S16Q-PTFNR/L 11			20	16	15	180	11	28	TN□□ 1103□□	VHX0509	S2	LV2	-	-
S20Q-PTFNR/L 11			25	20	18	180	13	31						
S25R-PTFNR/L 11			32	25	23	200	17	35						
S25R-PTFNR/L 16			32	25	23	200	17	42	TN□□ 1604□□	VHX0512	S2	LV3B	-	-
S32S-PTFNR/L 16			44	32	30	250	22	50						
S40T-PTFNR/L 16			54	40	37	300	27	55						

PWLNR/L

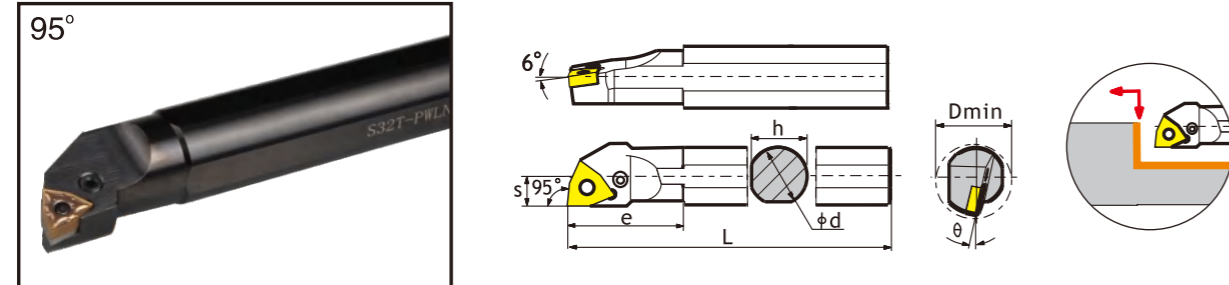

Type 型号	Dimension(mm) 基本尺寸								Applicable Inserts 使用的刀片	Screw 螺钉	Wrench 扳手	Lever 杠杆	Shim 刀垫	Shim pin 垫档						
	Stock 库存		Dmin	φd	h	L	s	e												
	R	L																		
S16Q-PWLNR/L06			20	16	15	180	11	-13°	25	WN□□ 0604□□	VHX0512	S2	LV3B	-	-					
S20Q-PWLNR/L06			25	20	18	180	13	-13°	32											
S25R-PWLNR/L06			32	25	23	200	17	-13°	35											
S20Q-PWLNR/L08			25	20	18	180	13	-13°	32	WN□□ 0804□□	VHX0613	S2.5	LV4A	-	-					
S25R-PWLNR/L08			32	25	23	200	17	-13°	45											
S32S-PWLNR/L08			40	32	30	250	22	-13°	50											
S40T-PWLNR/L08			50	40	42	300	30	-13°	55							VHX0821	S3	LV4	PW 08318	SP 4



车削刀具 | TURNING TOOLS

Internal turning toolholders 内孔车刀

DCLNR/L

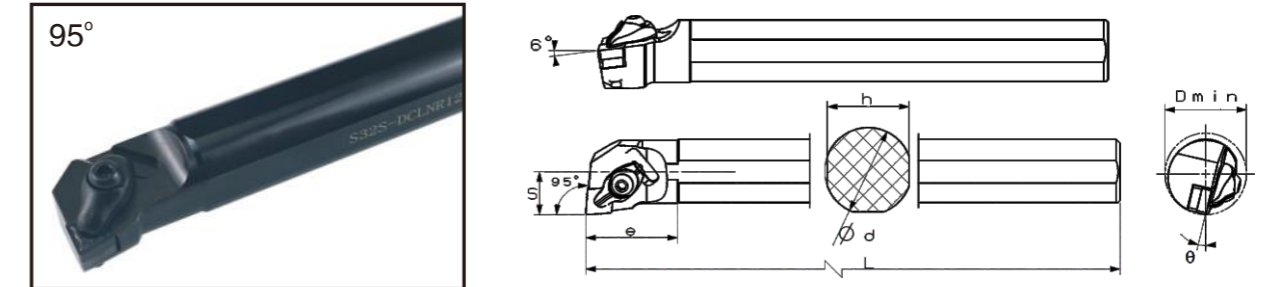

Type 型号	Dimension(mm) 基本尺寸								Applicable Inserts 使用的刀片	Shim 刀垫	Wrench 扳手	Clamp 压板	Clamp screw 压板螺丝	Screw 螺钉						
	Stock 库存		Dmin	φd	h	L	s	e												
	R	L																		
S25R-DCLNR/L 12-D			32	25	23	200	17	13	45	CN □□ 1204□□	MC1203	S3, T15	DML4	DM 0520	L60 M4*8.4					
S32S-DCLNR/L 12			40	32	30	250	21	13	45											
S40T-DCLNR/L 12			50	40	37	300	25	12	50											
S50U-DCLNR/L 12			60	50	47	350	32	12	55							MC 1204	S4, S3	DCL2612	DM 0625	DSP 0612

DWLNR/L

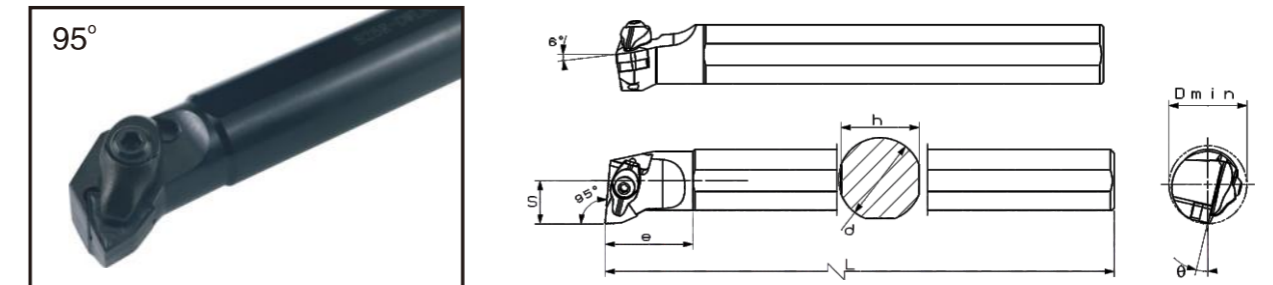

Type 型号	Dimension(mm) 基本尺寸								Applicable Inserts 使用的刀片	Shim 刀垫	Wrench 扳手	Clamp 压板	Clamp screw 压板螺丝	Screw 螺钉						
	Stock 库存		Dmin	φd	h	L	s	e												
	R	L																		
S25R-DWLNR/L 08-D			32	25	23	200	17	13	40	WN□□ 0804□□	MW 0803	S3, T15	DML4	DM 0520	L60 M4*8.4					
S32S-DWLNR/L 08			40	32	30	250	22	13	45											
S40T-DWLNR/L 08			50	40	37	300	24	12	50											
S50U-DWLNR/L 08			60	50	47	350	29	12	55							MW 0804	S4, S3	DCL2612	DM 0625	DSP 0612

车削刀具 | TURNING TOOLS



内孔车刀 Internal turning toolholders

SCLCR/L

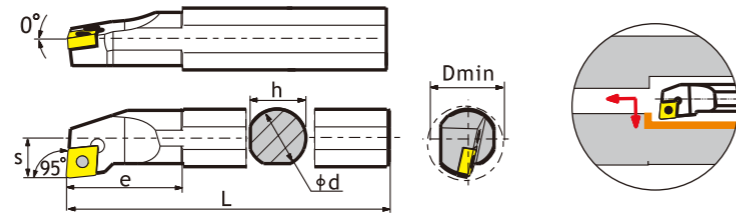

Type 型号	Dimension(mm) 基本尺寸							Applicable Inserts 使用的刀片	Screw 螺钉	Wrench 扳手	
	Stock 库存		Dmin	φd	h	L	s				e
	R	L									
S07K-SCLCR/L 06			9	7	6	125	4.6	15	CC ₀ T 0602 ₀₀	L60M2.5X5	T08
S08K-SCLCR/L 06			10	8	7	125	4.5	14			
S10K-SCLCR/L 06			12	10	9	125	6	17			
S12M-SCLCR/L 06			16	12	11	150	7	17			
S12M-SCLCR/L 09			16	12	11	150	8	25	CC ₀ T 09T3 ₀₀	L60M4X8	T15
S16Q-SCLCR/L 09			20	16	15	180	9	27			
S20Q-SCLCR/L 09			25	20	18	180	11	28			
S25R-SCLCR/L 09			32	25	23	200	14	35			
S25R-SCLCR/L 12			32	25	23	200	17	38	CC ₀ T 1204 ₀₀	L60M5X12	T20
S32S-SCLCR/L 12			36	32	30	250	18	45			
S40T-SCLCR/L 12			50	40	37	300	27	60			

SCLCR/L-H

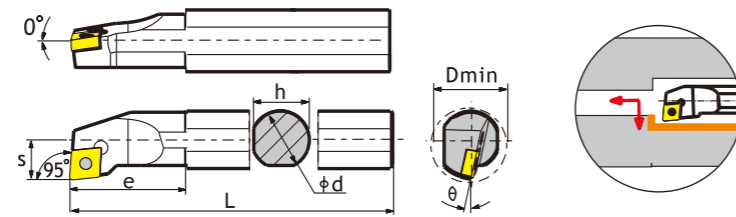

Type 型号	Dimension(mm) 基本尺寸							Applicable Inserts 使用的刀片	Screw 螺钉	Wrench 扳手		
	Stock 库存		Dmin	φd	h	L	s				θ°	e
	R	L										
S08K-SCLCR/L 06H09			9	8	7	125	4.3	-15°	15	CC ₀ T 0602 ₀₀	L60M2.5X5	T08
S10K-SCLCR/L 06H11			11	10	9	125	5.5	-13°	16			
S12M-SCLCR/L 06H13			13	12	11	150	6.5	-10°	17			
S16Q-SCLCR/L 09H17			17	16	15	180	8.5	-12°	27			

了解具体库存情况请致电厂家 详情请登陆网站www.hnsant.com



车削刀具 | TURNING TOOLS

Internal turning toolholders 内孔车刀

SCKCR/L

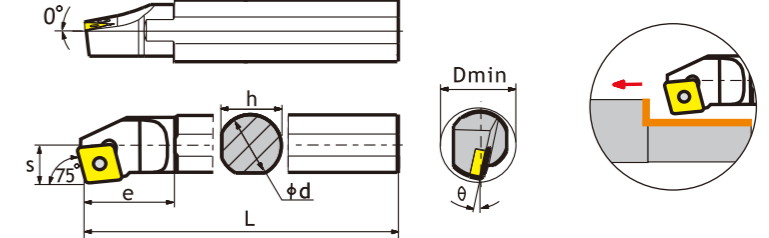

Type 型号	Dimension(mm) 基本尺寸							Applicable Inserts 使用的刀片	Screw 螺钉	Wrench 扳手		
	Stock 库存		Dmin	φd	h	L	s				θ°	e
	R	L										
S08K-SCKCR/L06			10	8	7.5	125	5.5	13°	15	CC ₀ T 0602 ₀₀	L60M2.5X5	T08
S10K-SCKCR/L06			13	10	9	125	7	12°	15			
S12M-SCKCR/L06			16	12	11	150	8	10°	20			
S12M-SCKCR/L09			16	12	11	150	8	12°	20			
S16Q-SCKCR/L09			20	16	15	160	10	10°	25	CC ₀ T 09T3 ₀₀	L60M4X8	T15
S20Q-SCKCR/L09			24	20	19	180	13	8°	30			
S25R-SCKCR/L09			31	25	24	200	16	8°	35			

SDQCR/L

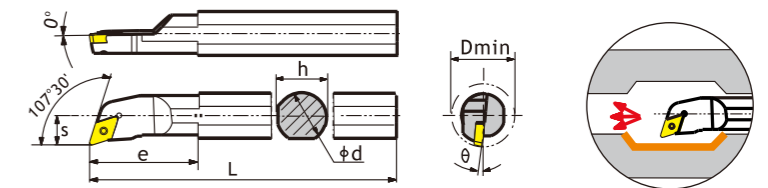

Type 型号	Dimension(mm) 基本尺寸							Applicable Inserts 使用的刀片	Screw 螺钉	Wrench 扳手		
	Stock 库存		Dmin	φd	h	L	s				θ°	e
	R	L										
S08K-SDQCR/L07			10	8	7	125	6	-8°	20	DC ₀ T 0702 ₀₀	L60M2.5X5	T08
S10K-SDQCR/L 07			13	10	9	125	7	-8°	20			
S12M-SDQCR/L 07			16	12	11	150	9	-8°	22			
S16Q-SDQCR/L 07			20	16	15	180	11	-6°	27			
S20Q-SDQCR/L 11			25	20	18	180	13	-6°	35	DC ₀ T 11T3 ₀₀	L60M4X8	T15
S25R-SDQCR/L 11			32	25	23	200	17	-6°	38			

了解具体库存情况请致电厂家 详情请登陆网站www.hnsant.com

SDXCR/L

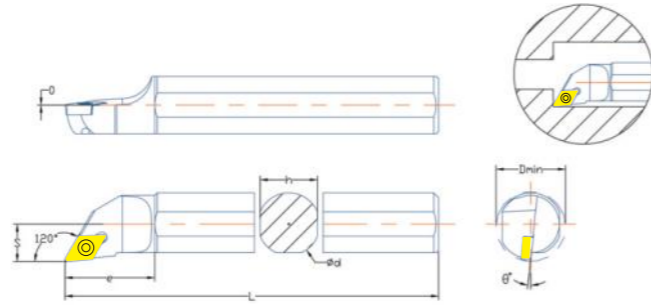

Type 型号	Dimension(mm) 基本尺寸								Applicable Inserts 使用的刀片	Screw 螺钉	Wrench 扳手	
	Stock 库存		Dmin	φd	h	L	s	θ'				e
	R	L										
S10K-SDXCR/L 07			13	10	9	125	7	-8°	18	DC□T 0702□□	L60M2.5X5	T08
S12M-SDXCR/L 07			16	12	11	150	8	-8°	20			
S16Q-SDXCR/L 07			20	16	15	180	10	-6°	25			
S20Q-SDXCR/L 11			25	20	18	180	13	-6°	33	DC□T 11T3□□	L60M4X8	T15
S25R-SDXCR/L 11			32	25	23	200	16	-6°	32			

SDWCR/L

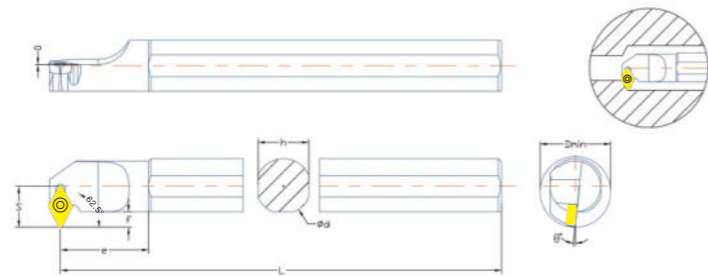

Type 型号	Dimension(mm) 基本尺寸										Applicable Inserts 使用的刀片	Screw 螺钉	Wrench 扳手
	Stock 库存		Dmin	φd	h	L	s	θ'	e	f			
	R	L											
S12M-SDWCR/L 07			19	12	11	125	11	-8°	15	5.5	DC□T 0702□□	L60M2.5X5	T08
S16Q-SDWCR/L 07			23	16	15	180	12.5	-8°	15	5			
S20Q-SDWCR/L 07			27	20	19	180	14.5	-8°	22	5.5			
S20Q-SDWCR/L 11			27	20	19	180	14.5	-6°	25	6	DC□T 11T3□□	L60M4X8	T15
S25R-SDWCR/L 11			32	25	24	200	18	-6°	25	7			
S32S-SDWCR/L 11			40	32	30	250	21.5	-6°	40	6.5			

SDUCR/L

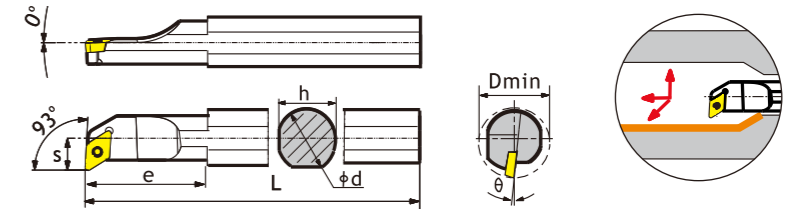

Type 型号	Dimension(mm) 基本尺寸										Applicable Inserts 使用的刀片	Screw 螺钉	Wrench 扳手
	Stock 库存		Dmin	φd	h	L	s	θ'	e	f			
	R	L											
S08K-SDUCR/L07			13	08	7.5	125	8	-8°	4	DC□ T0702□□	L60M2.5X5	T08	
S10K-SDUCR/L 07			13	10	9	125	7.7	-8°	3				
S12M-SDUCR/L 07			16	12	11	150	8.5	-8°	22				3
S16Q-SDUCR/L 07			20	16	15	180	11	-6°	27	3.5	DC□ T11T3□□	L60M4X8	T15
S20Q-SDUCR/L 11			25	20	18	180	14.5	-6°	30	5.5			
S25R-SDUCR/L 11			32	25	23	200	18.5	-6°	35	7			

SDZCR/L

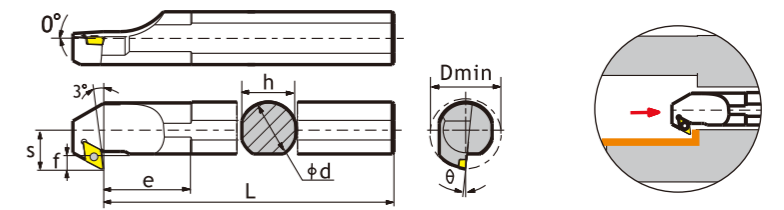

Type 型号	Dimension(mm) 基本尺寸										Applicable Inserts 使用的刀片	Screw 螺钉	Wrench 扳手
	Stock 库存		Dmin	φd	h	L	s	θ'	e	f			
	R	L											
S20Q-SDZCR/L11			27	20	18	180	16	-6°	20	7.5	DC□ T11T3□□	L60M4X8	T15
S25R-SDZCR/L 11			33	25	23	200	19	-6°	30	7.5			
S32S-SDZCR/L 11			40	32	30	250	23	-6°	35	8.4			
S40T-SDZCR/L 11			50	40	37	300	28	-4°	50	9.4			

车削刀具 | TURNING TOOLS



内孔车刀 Internal turning toolholders

SSKCR/L

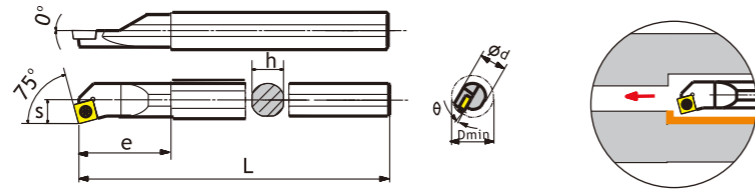

Type 型号	Dimension(mm) 基本尺寸								Applicable Inserts 使用的刀片	Screw 螺钉	Wrench 扳手	
	Stock 库存		Dmin	φd	h	L	s	θ°				e
	R	L										
S12M-SSKCR/L 09			16	12	11	150	9	-10°	25	SC□ T 09T3□□	L60M4X8	T15
S16Q-SSKCR/L 09			20	16	15	180	11	-11°	30			
S20Q-SSKCR/L 09			25	20	18	180	13	-6°	35			
S25R-SSKCR/L 09			32	25	23	200	17	-8°	40			
S25R-SSKCR/L 12			32	25	23	200	17	-8°	40			
S32S-SSKCR/L 12			40	32	30	250	22	-10°	45			

SSSCR/L

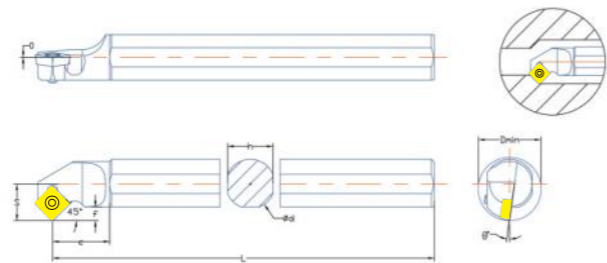

Type 型号	Dimension(mm) 基本尺寸										Applicable Inserts 使用的刀片	Screw 螺钉	Wrench 扳手
	Stock 库存		Dmin	φd	h	L	s	θ°	e	f			
	R	L											
S12M-SSSCR/L 09			17	12	11	150	10	-10°	15	4.5	SC□ T 09T3□□	L60M4X8	T15
S16Q-SSSCR/L 09			22	16	15	180	13	-11°	25	5.5			
S20Q-SSSCR/L 09			25	20	18	180	15	-6°	30	6			
S25R-SSSCR/L 09			32	25	23	200	17	-8°	35	5.5			
S25R-SSSCR/L 12			32	25	23	200	17	-8°	35	5.5			
S32S-SSSCR/L 12			40	32	30	250	22	-10°	40	7			

了解具体库存情况请致电厂家 详情请登陆网站www.hnsant.com

车削刀具 | TURNING TOOLS



内孔车刀 Internal turning toolholders

STFCR/L

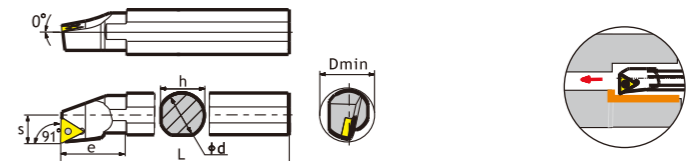

Type 型号	Dimension(mm) 基本尺寸								Applicable Inserts 使用的刀片	Screw 螺钉	Wrench 扳手
	Stock 库存		Dmin	φd	h	L	s	e			
	R	L									
S08K-STFCR/L09			10	08	7	125	5.5	8	TC□ T 0902□□	L60M2.2X6	T06
S10K-STFCR/L09			12	10	9	125	6.8	10			
S12M-STFCR/L09			16	12	11	150	8	10			
S12M-STFCR/L11			14	12	11	150	6.5	25			
S16Q-STFCR/L 11			18	16	15	180	9	25			
S20Q-STFCR/L 11			25	20	18	180	11	25			
S25R-STFCR/L 16			32	25	23	200	17	40			
S32S-STFCR/L 16			36	32	30	250	18	50			
S40T-STFCR/L 16			50	40	37	300	25	60	TC□ T 16T3□□	L60M4X8	T15

STWCR/L

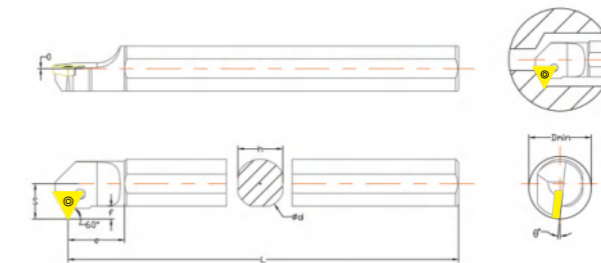

Type 型号	Dimension(mm) 基本尺寸								Applicable Inserts 使用的刀片	Screw 螺钉	Wrench 扳手	
	Stock 库存		Dmin	φd	h	L	s	θ°				e
	R	L										
S10K-STWCR/L 11			14	10	9	125	8	-10°	14	TC□ T 1102□□	L60M2.5X5	T08
S12M-STWCR/L 11			16	12	11	150	9	-13°	25			
S16Q-STWCR/L 11			20	16	15	180	11	-10°	30			
S20Q-STWCR/L 11			25	20	19	180	13	-6°	30			
S25R-STWCR/L 11			32	25	24	200	17	-6°	35			
S20Q-STWCR/L 16			25	20	19	180	14.5	-3°	36			
S25R-STWCR/L 16			32	25	24	200	17	-6°	49			
S32S-STWCR/L 16			39	32	30	250	22	-10°	50			
S40T-STWCR/L 16			50	40	37	300	25	-8°	50			

了解具体库存情况请致电厂家 详情请登陆网站www.hnsant.com

车削刀具 | TURNING TOOLS



内孔车刀 Internal turning toolholders

STFPR/L

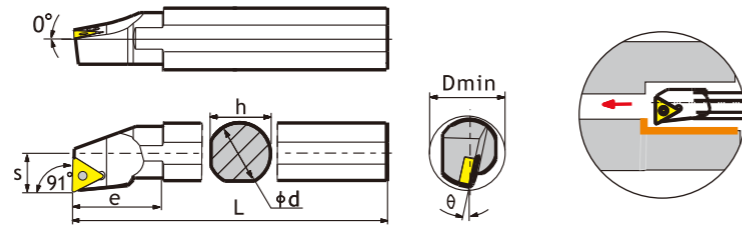

Type 型号	Dimension(mm) 基本尺寸								Applicable Inserts 使用的刀片	Screw 螺钉	Wrench 扳手
	Stock 库存		Dmin	φd	h	L	s	θ			
	R	L									
S08K-STFPR/L09			10	08	7	125	5	-10°	14	TP□ T 0902□□ (京瓷)	
S10K-STFPR/L11H11			11	10	9	125	5.5	-13°		TP□ T 1103□□ (Zccet)	L60M2.5X5
S12M-STFPR/L 11H13			13	12	11	150	6.8	-10°			
S16Q-STFPR/L 11H17			17	16	15	180	8.8	-6°			

STUCR/L

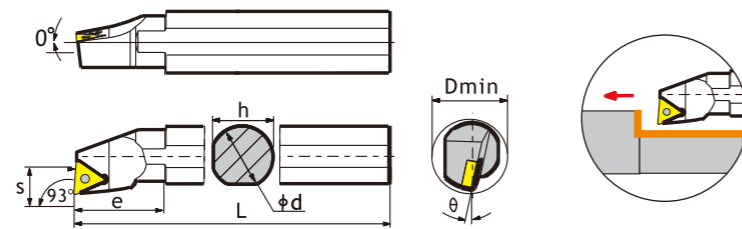

Type 型号	Dimension(mm) 基本尺寸								Applicable Inserts 使用的刀片	Screw 螺钉	Wrench 扳手
	Stock 库存		Dmin	φd	h	L	s	θ			
	R	L									
S08K-STUCR/L09			11	08	7	125	5.5	-15°		TC□ T 0902□□	L60M2.2X6
S08K-STUCR/L09-A16			11	16	15	125	5.5	-15°	24		
S10K-STUCR/L09			13	10	9	125	6	-13°	10		
S10K-STUCR/L09-A16			13	16	15	125	7	-13°	30	TC□ T 1102□□	L60M2.5X5
S10K-STUCR/L11			13	10	9	125	7	-12°	10		
S10K-STUCR/L11-A16			16	16	15	125	7	-12°	30		
S12M-STUCR/L11			16	12	11	150	7	-10°	25	TC□ T 16T3□□	L60M4X8
S12M-STUCR/L11-A16			16	16	15	150	7	-10°	30		
S16Q-STUCR/L11			20	16	15	180	9	-8°	25		
S20Q-STUCR/L11			25	20	19	180	11	-6°	25		
S25R-STUCR/L11			31	25	24	200	15	-4°	34		
S20Q-STUCR/L16			25	20	19	180	13	-8°	36		
S25R-STUCR/L16			31	25	24	200	17	-6°	40		
S32S-STUCR/L16			39	32	30	250	18	-4°	50		
S40T-STUCR/L16			50	40	38	300	25	-2°	60		

了解具体库存情况请致电厂家 详情请登陆网站www.hnsant.com



车削刀具 | TURNING TOOLS

Internal turning toolholders 内孔车刀

SVQCR/L

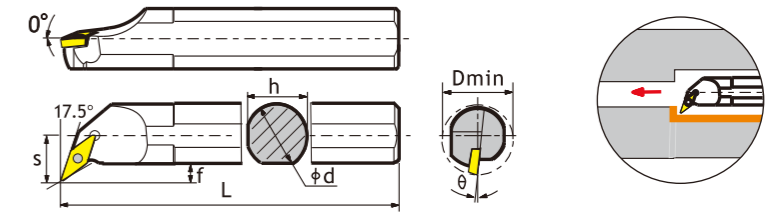

Type 型号	Dimension(mm) 基本尺寸									Applicable Inserts 使用的刀片	Screw 螺钉	Wrench 扳手
	Stock 库存		Dmin	φd	h	L	s	θ	e			
	R	L										
S20Q-SVQCR/L16			27	20	18	180	15	-8°	40	6.0	VC□ T 1604□□	L60M4X8
S25R-SVQCR/L16			32	25	23	200	18.5	-8°	45	6.9		
S32S-SVQCR/L 16			40	32	30	250	22	-8°	56	8.4		
S40T-SVQCR/L 16			50	40	37	300	27	-8°	64	9.4		

SVQBR/L

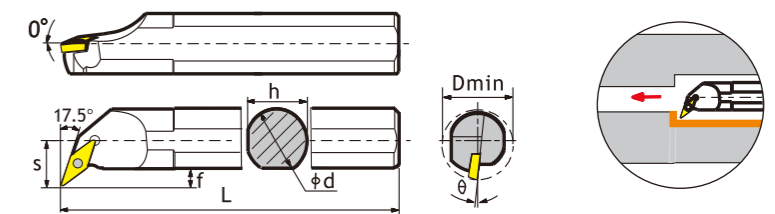

Type 型号	Dimension(mm) 基本尺寸									Applicable Inserts 使用的刀片	Screw 螺钉	Wrench 扳手
	Stock 库存		Dmin	φd	h	L	s	θ	e			
	R	L										
S20Q-SVQBR/L16			27	20	18	180	15	-8°	40	6.0	VB□ T 1604□□	L60M4X8
S25R-SVQBR/L16			32	25	23	200	18.5	-8°	45	6.9		
S32S-SVQBR/L 16			40	32	30	250	22	-8°	56	8.4		
S40T-SVQBR/L 16			50	40	37	300	27	-8°	64	9.4		

了解具体库存情况请致电厂家 详情请登陆网站www.hnsant.com

车削刀具 | TURNING TOOLS



内孔车刀 Internal turning toolholders

SVUCR/L

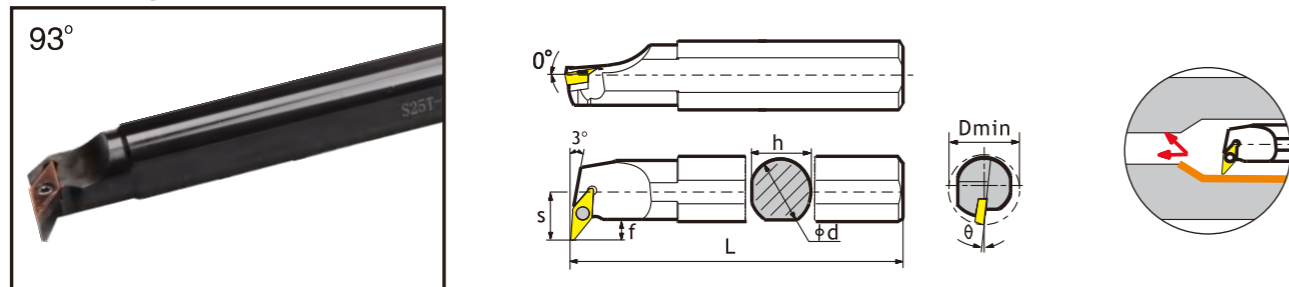

Type 型号	Dimension(mm) 基本尺寸								Applicable Inserts 使用的刀片	Screw 螺钉	Wrench 扳手	
	Stock 库存		Dmin	φd	h	L	s	e				f
	R	L										
S16Q-SVUCR/L11			22	16	15	180	13.5	24	6	VC T 1103□	L60M2.5X5	T08
S20Q-SVUCR/L16			31	20	19	180	19	32	9.5			
S25R-SVUCR/L16			35	25	23	200	20	32	8.4	VC T 1604□	L60M4X8	T15
S32S-SVUCR/L 16			42	32	30	250	22	49	8.4			
S40T-SVUCR/L 16			51	40	37	300	27	49	11			

SVWCR/L

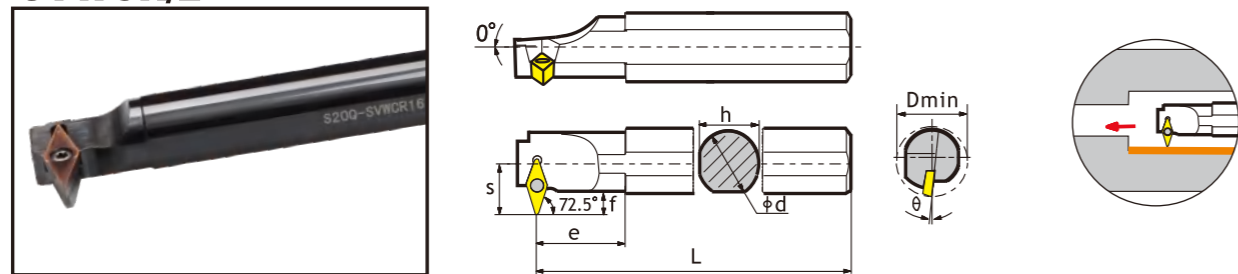

Type 型号	Dimension(mm) 基本尺寸								Applicable Inserts 使用的刀片	Screw 螺钉	Wrench 扳手	
	Stock 库存		Dmin	φd	h	L	s	e				f
	R	L										
S16Q-SVWCR/L11			25	16	15	180	14	25	6.9	VC T 1103□	L60M2.5X5	T08
S20Q-SVWCR/L16			32	20	18	180	22	25	12.9			
S25R-SVWCR/L16			36	25	23	200	22	30	10	VC T 1604□	L60M4X8	T15
S32S-SVWCR/L 16			45	32	30	250	27	42	12.2			
S40T-SVWCR/L 16			55	40	37	300	30	50	11			

车削刀具 | TURNING TOOLS



Tungsten steel Internal Turning tools 钨钢内孔车刀

SVXCR/L

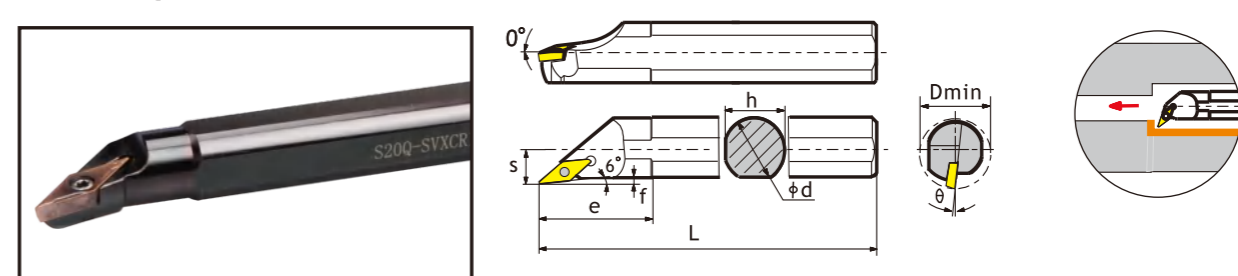

Type 型号	Dimension(mm) 基本尺寸								Applicable Inserts 使用的刀片	Screw 螺钉	Wrench 扳手	
	Stock 库存		Dmin	φd	h	L	s	e				f
	R	L										
S16Q-SVXCR/L11			20	16	15	180	9.5	35	2	VC T 1103□	L60M2.5X5	T08
S20Q-SVXCR/L16			25	20	18	180	13	40	4			
S25R-SVXCR/L16			32	25	23	200	14.5	40	3	VC T 1604□	L60M4X8	T15
S32S-SVXCR/L 16			40	32	30	250	21	62	6			
S40T-SVXCR/L 16			50	40	37	300	24	62	5.5			

SVZCR/L

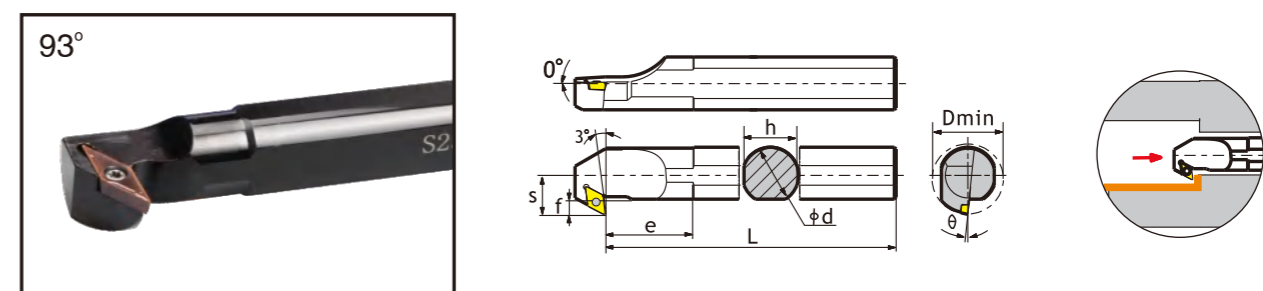

Type 型号	Dimension(mm) 基本尺寸								Applicable Inserts 使用的刀片	Screw 螺钉	Wrench 扳手	
	Stock 库存		Dmin	φd	h	L	s	e				f
	R	L										
S16Q-SVZCR/L 11			22	16	15	180	13.5	15	6.5	VC T 1103□	L60M2.5X5	T08
S20Q-SVZCR/L 11			28	20	18	180	16	22	7.5			
S25R-SVZCR/L 16			34	25	23	200	21	30	10	VC T 1604□	L60M4X8	T15
S32S-SVZCR/L 16			40	32	30	250	23	35	9			
S40T-SVZCR/L 16			50	40	37	300	29	40	11			

车削刀具 | TURNING TOOLS



钨钢内孔车刀 Tungsten steel Internal Turning tools

SWUBR/L

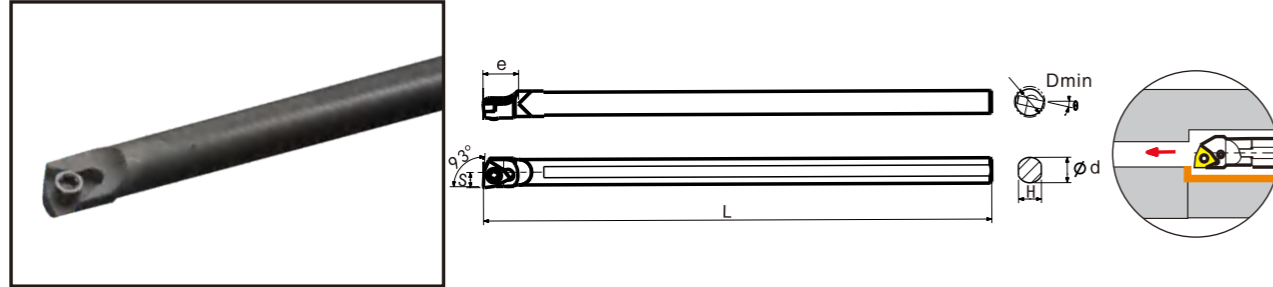

Type 型号	Dimension(mm) 基本尺寸								Applicable Inserts 使用的刀片	Screw 螺钉	Wrench 扳手	
	Stock 库存		Dmin	φd	h	L	s	θ°				e
	R	L										
C05H-SWUBR/L06			6	5	4.5	100	3	-13°	7	WB-T0601□	L60M2.0X4.3	T06
C06J-SWUBR/L06			7	6	5.5	110	3.5	-13°	7			

SCLCR/L

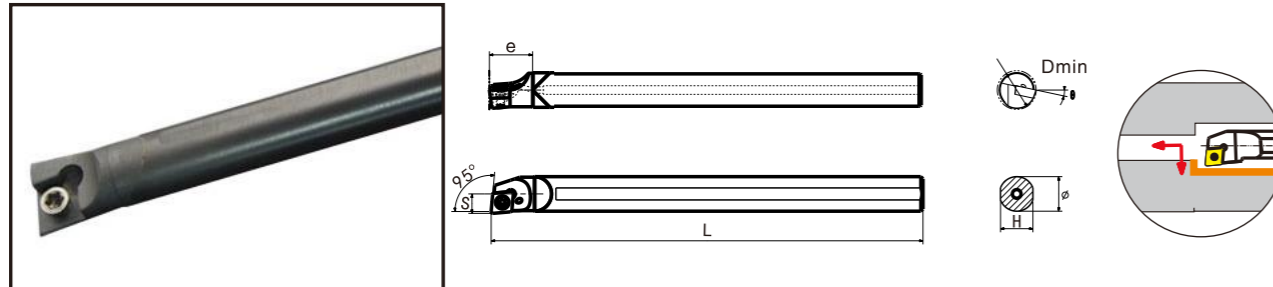

Type 型号	Dimension(mm) 基本尺寸								Applicable Inserts 使用的刀片	Screw 螺钉	Wrench 扳手	
	Stock 库存		Dmin	φd	h	L	s	θ°				e
	R	L										
C07K-SCLCR/L06			10	7	6.5	125	4.5	-15°	8	CC-T0602□	L60M2.5X5	T08
C08K-SCLCR/L06			10	8	7.5	125	5	-15°	8			
C10M-SCLCR/L06			12	10	9.5	150	6	-13°	14			
C12Q-SCLCR/L06			14	12	11	180	7	-10°	14			
C12Q-SCLCR/L09			16	12	11	180	8	-10°	14	CC-T09T3□	L60M4X8	T15
C14Q-SCLCR/L09			16	14	13	180	8	-12°	18			
C16R-SCLCR/L09			18	16	15	200	9	-12°	20			
C20S-SCLCR/L09			22	20	19	250	11	-8°	26			
C25T-SCLCR/L09			28	25	23	300	14	-6°	29			

备注：钨钢抗震内孔刀杆我司可提供带内冷和不带内冷两种型号供客户选择
 Note:Tungsten steel Anti-shaking Internal Turning tools with coolant hole or without coolant hole both can be offered.

了解具体库存情况请致电厂家 详情请登陆网站www.hnsant.com

车削刀具 | TURNING TOOLS



Tungsten steel Internal Turning tools 钨钢内孔车刀

STFCR/L

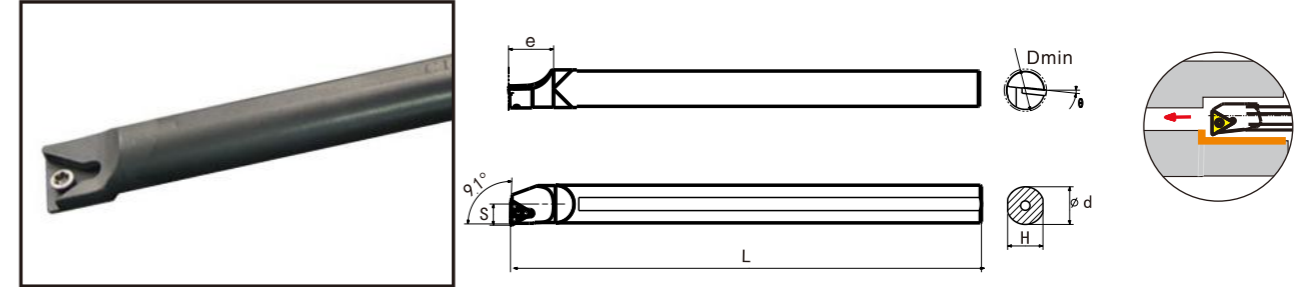

Type 型号	Dimension(mm) 基本尺寸								Applicable Inserts 使用的刀片	Screw 螺钉	Wrench 扳手	
	Stock 库存		Dmin	φd	h	L	s	θ°				e
	R	L										
C08K-STFCR/L09			10	8	7.5	125	5	-10	8	TC-T0902□	L60M2.2X6	T06
C10M-STFCR/L09			12	10	9.5	150	6	-10	14			
C12Q-STFCR/L09			16	12	11	180	8	-5	14			
C12Q-STFCR/L11			16	12	11	180	8	-6	14	TC-T1102□	L60M2.5X5.0	T08
C16R-STFCR/L11			18	16	15	200	9	-6	20			
C20S-STFCR/L11			25	20	19	250	12	-6	26			

STUPR/L

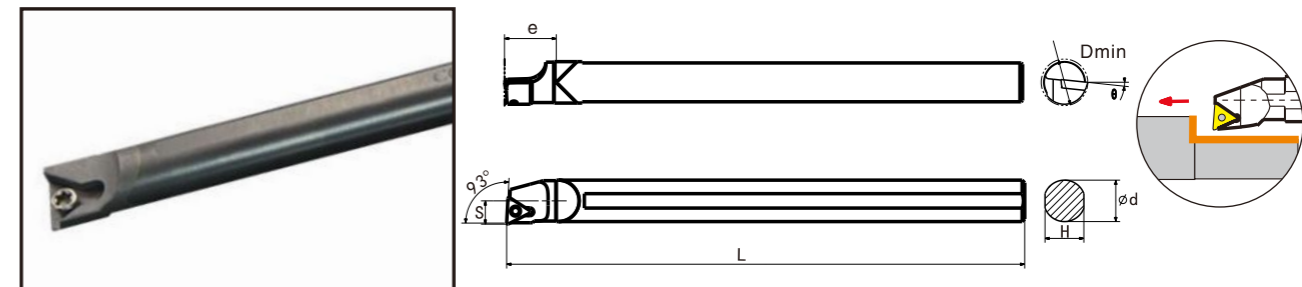

Type 型号	Dimension(mm) 基本尺寸								Applicable Inserts 使用的刀片	Screw 螺钉	Wrench 扳手	
	Stock 库存		Dmin	φd	h	L	s	θ°				e
	R	L										
C08K-STUPR/L09			11	8	7.5	125	5.5	-10	8	TP-T0902□(京瓷)	L60M2.5X5.0	T08
C10M-STUPR/L09			13	10	9.5	150	6.5	-8	14			
C12Q-STUPR/L09			16	12	11	180	7.5	-6	14			
C12Q-STUPR/L11			16	12	11	180	7.5	-6	14	TP-T1103□(京瓷)	L60M3.0X7	T10
C16R-STUPR/L11			18	16	15	200	9	-6	20			
C20S-STUPR/L11			25	20	19	250	12	-6	26			

备注：钨钢抗震内孔刀杆我司可提供带内冷和不带内冷两种型号供客户选择
 Note:Tungsten steel Anti-shaking Internal Turning tools with coolant hole or without coolant hole both can be offered.

了解具体库存情况请致电厂家 详情请登陆网站www.hnsant.com

车削刀具 | TURNING TOOLS



钨钢内孔车刀 Tungsten steel Internal Turning tools

SDQCR/L

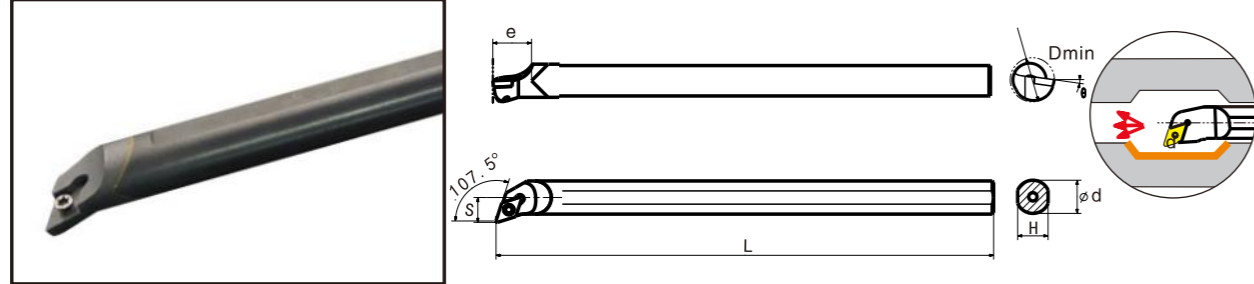

Type 型号	Dimension(mm) 基本尺寸								Applicable Inserts 使用的刀片	Screw 螺钉	Wrench 扳手	
	Stock库存		Dmin	φd	h	L	s	e°				e
	R	L										
C10M-SDQCR/L07			13	10	9.5	150	7	-8°	14	DC□T0702□□	L60M2.5X5.0	T08
C12Q-SDQCR/L07			16	12	11	180	9	-8°	14			
C16R-SDQCR/L07			20	16	15	180	13	-6°	20			

SDUCR/L

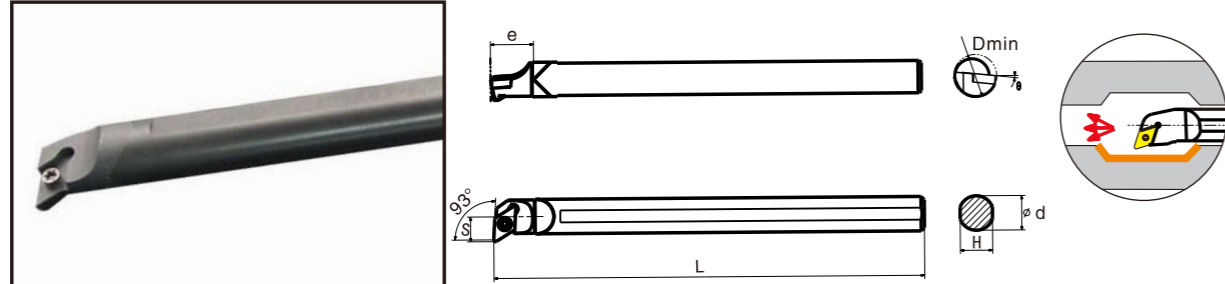

Type 型号	Dimension(mm) 基本尺寸								Applicable Inserts 使用的刀片	Screw 螺钉	Wrench 扳手	
	Stock库存		Dmin	φd	h	L	s	e°				e
	R	L										
C10M-SDUCR/L07			13	10	9.5	150	7	-8°	14	DC□T0702□□	L60M2.5X5.0	T08
C12Q-SDUCR/L07			16	12	11	180	9	-8°	14			
C16R-SDUCR/L07			20	16	15	200	11	-8°	20			
C20S-SDUCR/L07			25	20	19	250	13	-6°	16			

备注：钨钢抗震内孔刀杆我司可提供带内冷和不带内冷两种型号供客户选择
 Note: Tungsten steel Anti-shaking Internal Turning tools with coolant hole or without coolant hole both can be offered.



车削刀具 | TURNING TOOLS

Threading toolholders code key 螺纹刀的型号表示规则

R

右切 Right

L

左切 Left

只标注到整数 例:h=8mm,标为08
Integers to be preceded by 0
eg:h=8 indicated by 08

注：圆刀杆用00表示

例:b=8mm,标为08
Integers to be preceded by 0
eg:b=8 indicated by 08

注：圆刀杆就用直径表示

代号 Code	长度 Length
H	100
K	125
M	150
P	170
Q	180
R	200
S	250

3.切削方向 Cutting direction 范例 Example

4.刀尖高度 Tools-tip height

5.刀体宽度 Shank width

6.刀杆长度 Tool holder length

1.压紧方式 Clamping System

2.螺纹形式 Type of thread

7.刀片尺寸 Insert dimension

S W R 25 25 M 16

C

压板压紧式
Top clamping

N	内螺纹 Internal
W	外螺纹 External

代号 Code	三角形边长 Cutting edge length	内切圆 Inscribed circle dia.
11	11	6.305
16	16	9.525
22	22	12.70
27	27	15.89

S

螺钉压紧式
Screw on

外螺纹车刀 External threading tools

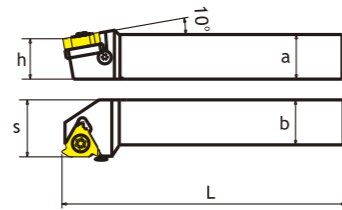

Type 型号	Dimension(mm) 基本尺寸						Applicable Inserts 使用的刀片	Screw 刀片螺钉	Shim 刀垫	Shim Screw 刀垫螺钉	Wrench 扳手	
	Stock 库存		a	h	b	L						s
	R	L										
SWR/L	1010H11H		10	10	10	100	16	R/LT11.01W-□□GM	L60 M2.5 × 6	—	—	T08
	1212H11H		12	12	12	100	16					
	1616H16H		16	16	16	100	20					
	2020K16H		20	20	20	125	25	R/LT16.01W-□□GM	L60 M3.5 × 12	TT16-□□	SS04008	T15 S2.5
	2525M16H		25	25	25	150	32					
	3225P16H		32	32	25	170	32					
	3232P16H		32	32	32	170	40					
	2525M22H		25	25	25	150	32	R/LT22.01W-□□GM	L60 M5 × 16	TT22-□□	SS04008	T20 S2.5
	3225P22H		32	32	25	170	32					
	3232P22H		32	32	32	170	40					
4040S22H		40	40	40	250	50						

★注明：配套刀片建议参考株洲钻石。Note:The insert is Zccct brand.

Type 型号	Dimension(mm) 基本尺寸						Applicable Inserts 使用的刀片	Screw 刀片螺钉	Shim 刀垫	Shim Screw 刀垫螺钉	Wrench 扳手	
	Stock 库存		a	h	b	L						s
	R	L										
SWR/L	1010H11		10	10	10	100	16	11ER/L	L60 M2.5 × 6	—	—	T08
	1212H11		12	12	12	100	16					
	1616H16		16	16	16	100	20					
	2020K16		20	20	20	125	25	16ER/L	L60 M3.5 × 12	TT16-□□	SS04008	T15 S2.5
	2525M16		25	25	25	150	32					
	3225P16		32	32	25	170	32					
	3232P16		32	32	32	170	40					
	2525M22		25	25	25	150	32	22ER/L	L60 M4 × 16	TT22-□□	SS04008	T20 S2.5
	3225P22		32	32	25	170	32					
	3232P22		32	32	32	170	40					
	4040S22		40	40	40	250	50					
	3232P27		32	32	32	170	40	27ER/L	L60 M6 × 16	TT27-□□	SS04008	T20 S2.5
	4040S27		40	40	40	250	50					

★注明：配套刀片建议参考ISO国标刀片。Note:The insert is ISO brand.

内螺纹车刀 Internal threading tools

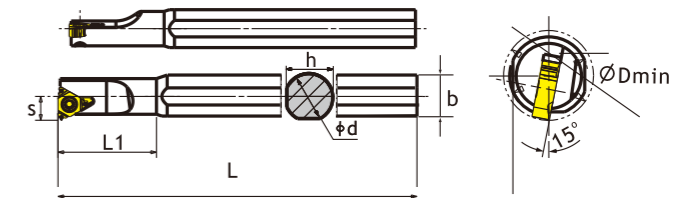

Type 型号	Dimension(mm) 基本尺寸								Applicable Inserts 使用的刀片	Shim 刀垫	Screw 螺钉	Wrench 扳手	Shim Screw 刀垫螺钉	
	Stock 库存		d	L	b	Dmin	s	h						L1
	R	L												
SNR/L0010K11H			10	125	12	6	9.5	32	LT11.01N-□□GM	—	L60 M2.5 × 5	T08		
SNR/L0012K11H			12	125	16	6	11.5	32						
SNR/L0013M16H			13	150	16	10	15.5	32	LT16.01N-□□GM	—	L60 M3.5 × 8	T15		
SNR/L0016M16H			16	150	20	12	15.5	40						
SNR/L0020Q16H			20	180	25	14	19.5	40						
SNR/L0025R16H			25	200	30	16	24	45						
SNR/L0032S16H			32	250	38	20	30	55	RT16.01N-□□GM	TT16	L60 M3.5 × 12	T15 S2.5	SS04008	
SNR/L0025R22H			25	200	30	18	24	45						
SNR/L0032S22H			32	250	38	22	30	55	RT22.01N-□□GM	TT22	L60 M5 × 16	T20 S2.5	SS04008	
SNR/L0040T22H			40	300	46	26	38	60						

★注明：配套刀片建议参考株洲钻石。Note:The insert is Zccct brand.

Type 型号	Dimension(mm) 基本尺寸								Applicable Inserts 使用的刀片	Shim 刀垫	Screw 螺钉	Wrench 扳手	Shim Screw 刀垫螺钉	
	Stock 库存		d	L	b	Dmin	s	h						L1
	R	L												
SNR/L0010K11			10	125	12	6	9.5	32	111R/L	—	L60 M2.5 × 5	T08		
SNR/L0012K11			12	125	16	6	11.5	32						
SNR/L0013M16			13	150	16	10	15.5	32	161R/L	—	L60 M3.5 × 8	T15		
SNR/L0016M16			16	150	20	12	15.5	40						
SNR/L0020Q16			20	180	25	14	19.5	40						
SNR/L0025R16			25	200	30	16	24	45						
SNR/L0032S16			32	250	38	20	30	55	161R/L	TT16	L60 M3.5 × 12	S2.5	SS04008	
SNR/L0025R22			25	200	30	18	24	45						
SNR/L0032S22			32	250	38	22	30	55	221R/L	TT22	L60 M4 × 16	T20 S2.5	SS04008	
SNR/L0040T22			40	300	46	26	38	60						
SNR/L0032S27			32	250	40	24	30	55	271R/L	TT27	L60 M6 × 16	T20 S2.5	SS04008	
SNR/L0040T27			40	300	50	30	38	60						

★注明：配套刀片建议参考ISO国标刀片。Note:The insert is ISO brand.

切断切槽刀杆命名规则

Parting and grooving holders code key

外圆、端面切断切槽刀具

External and surface cutting

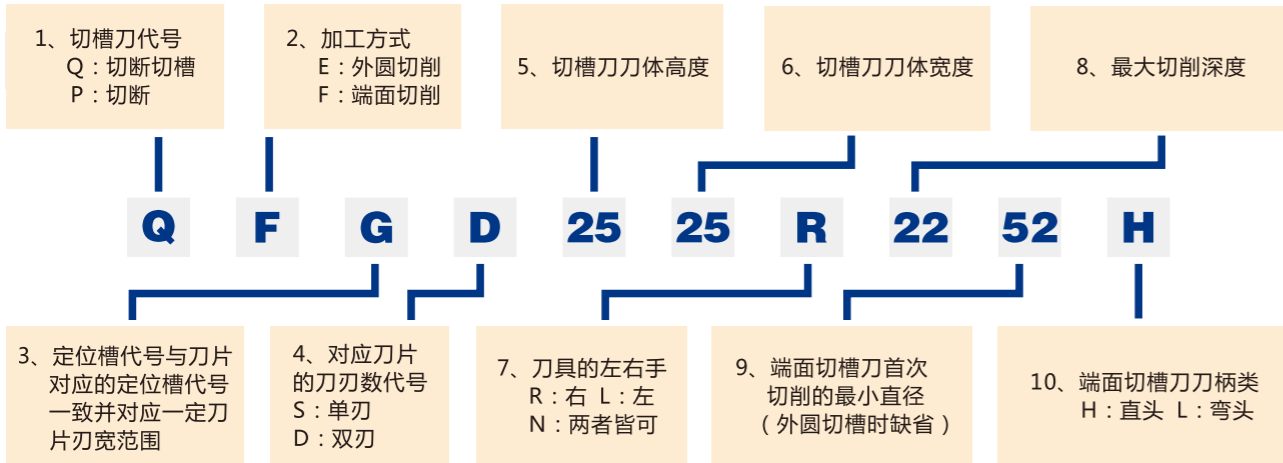

内圆切槽刀具

Internal cutting

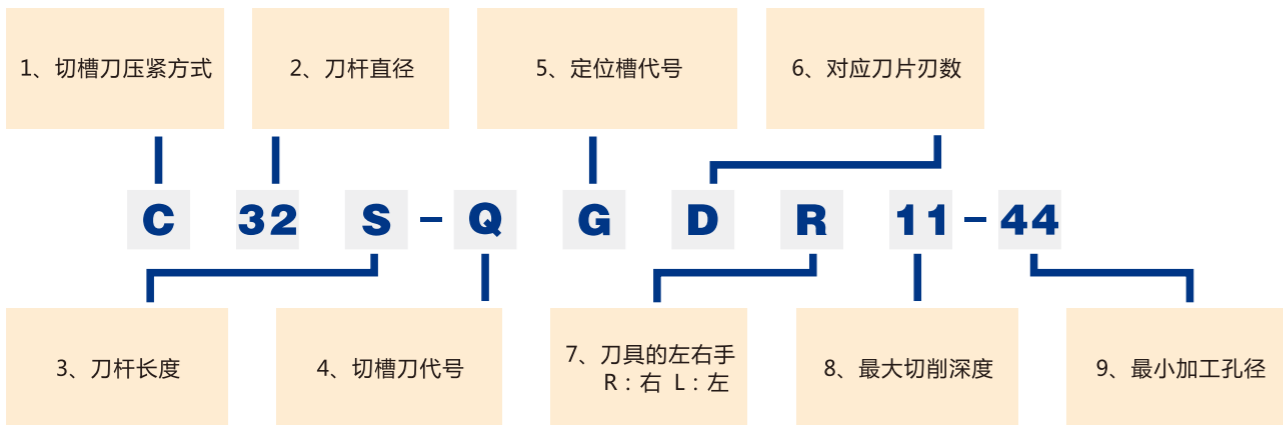

用于切断刀板的刀座

Height of blades

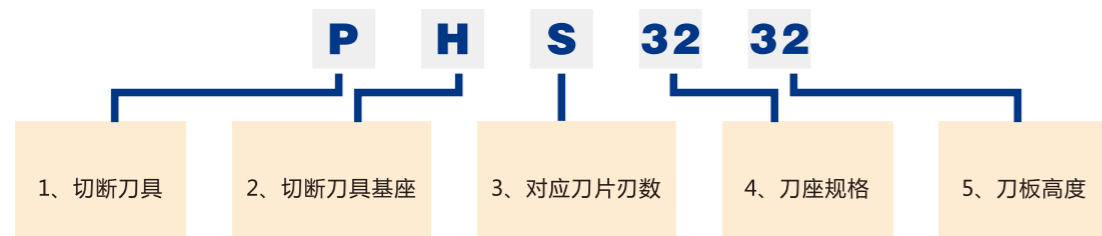

外圆切断、切槽刀具

External Parting, Grooving and Turning Tools

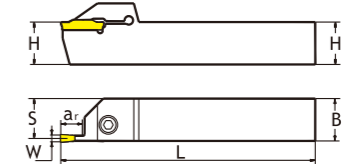

Type 型号	基本尺寸 Dimension(mm)						刀片 Inserts	螺钉 Screw	扳手 Wrench
	H×B	L	S	W	最大切深 a _{max}				
QEED	1616R/L10	16x16	100	15	2.5	10	Z*ED*****	M5 × 20	S4
	1616R/L17	16x16	100	15	2.5	17	Z*ED*****		
	2020R/L10	20x20	125	19	2.5	10	Z*ED*****	M6 × 20	S5
	2020R/L17	20x20	125	19	2.5	17	Z*ED*****		
	2525R/L10	25x25	150	24	2.5	10	Z*ED*****		
	2525R/L17	25x25	150	24	2.5	17	Z*ED*****		
QEFD	1616R/L10	16x16	100	14.8	3	10	Z*FD*****	M5 × 20	S4
	1616R/L17	16x16	100	14.8	3	17	Z*FD*****		
	2020R/L10	20x20	125	18.8	3	10	Z*FD*****	M6 × 20	S5
	2020R/L17	20x20	125	18.8	3	17	Z*FD*****		
	2525R/L10	25x25	150	23.8	3	10	Z*FD*****		
	2525R/L17	25x25	150	23.8	3	17	Z*FD*****		
QEGD	2020R/L13	20x20	125	18.5	4	13	Z*GD*****	M6 × 20	S5
	2020R/L 22	20x20	125	18.5	4	22	Z*GD*****		
	2525R/L13	25x25	150	23.5	4	13	Z*GD*****		
	2525R/L 22	25x25	150	23.5	4	22	Z*GD*****		
	3232R/L13	32x32	170	30.5	4	13	Z*GD*****		
	3232R/L 22	32x32	170	30.5	4	22	Z*GD*****		
QEHD	2525R/L13	25x25	150	23	5	13	Z*HD*****	M6 × 20	S5
	2525R/L 22	25x25	150	23	5	22	Z*HD*****		
QEHS	2525N 30	25x25	150	12.5	5	30	Z*HS*****	M6 × 20	S5
QEHD	3232R/L13	32x32	170	30	5	13	Z*HD*****		
QEHD	3232R/L 22	32x32	170	30	5	22	Z*HD*****		
QEHS	3232N 30	32x32	170	16	5	30	Z*HS*****		
QEKD	2525R/L13	25x25	150	22.6	6	13	Z*KD*****		
QEKD	2525R/L 22	25x25	150	22.6	6	22	Z*KD*****		
QEKS	2525N 30	25x25	150	12.5	6	30	Z*KS*****	M6 × 20	S5
QEKD	3232R/L13	32x32	170	29.6	6	13	Z*KD*****		
QEKD	3232R/L 22	32x32	170	29.6	6	22	Z*KD*****		
QEKS	3232N 30	32x32	170	16	6	30	Z*KS*****		

★ 可安装切断、切槽、车削、仿形刀片。
Parting, grooving, turning, profiling inserts are adaptable to the tools.

外圆切断、切槽刀具

External Parting, Grooving and Turning Tools

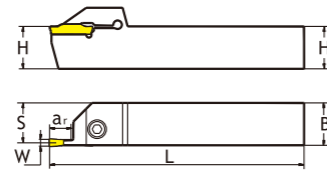

Type 型号	基本尺寸 Dimension(mm)						刀片 Inserts	螺钉 Screw	扳手 Wrench
	H	L	S	W	最大切深 a _{r,max}				
MGEHR/L	1616-2	16	100	15	2	14.5	MGMN200-M	M5 x 17	S4
	2020-2	20	125	19	2	14.5	MGMN200-M	M6 x 20	S5
	2525-2	25	150	24	2	14.5	MGMN200-M	M6 x 20	S5
	1616-2.5	16	100	15	2.5	16.5	MGMN250-M	M5 x 17	S4
	2020-2.5	20	125	19	2.5	16.5	MGMN250-M	M6 x 20	S5
	2525-2.5	25	150	24	2.5	16.5	MGMN250-M	M6 x 20	S5
	1616-3	16	100	14.8	3	18	MGMN300-M	M5 x 17	S4
	2020-3	20	125	18.8	3	18	MGMN300-M		
	2020-3-T10	20	125	18.8	3	10	MGMN300-M		
	2525-3	25	150	23.8	3	18	MGMN300-M	M6 x 20	S5
	2525-3-T10	25	150	23.8	3	10	MGMN300-M		
	3232-3	32	170	30.5	3	18	MGMN300-M		
	3232-3-T10	32	170	30.5	3	10	MGMN300-M		
	2020-4	20	125	18.5	4	18	MGMN400-M		
	2020-4-T10	20	125	18.5	4	10	MGMN400-M		
	2525-4	25	150	23.5	4	18	MGMN400-M		
	2525-4-T10	25	150	23.5	4	10	MGMN400-M		
	3232-4	32	170	30.5	4	18	MGMN400-M		
	3232-4-T10	32	170	30.5	4	10	MGMN400-M		
	2020-5	20	150	18	5	23	MGMN500-M	M6 x 20	S5
	2020-5-T15	20	150	18	5	15	MGMN500-M		
	2525-5	25	150	23	5	23	MGMN500-M		
	2525-5-T15	25	150	23	5	15	MGMN500-M		
	3232-5	32	170	30	5	23	MGMN500-M		
	3232-5-T15	32	170	30	5	15	MGMN500-M		
	2020-6	20	125	17	6	23	MGMN600-M		
	2020-6-T10	20	125	17	6	10	MGMN600-M		
	2525-6	25	150	22.6	6	23	MGMN600-M		
2525-6-T15	25	150	22.6	6	15	MGMN600-M			
3232-6	32	170	29.6	6	23	MGMN600-M			
3232-6-T15	32	170	29.6	6	15	MGMN600-M			

★ 可安装切断、切槽、车削、仿形刀片。(配套韩国克洛依刀片) Note:The insert is Korloy brand.
Parting, grooving, turning, profiling inserts are adaptable to the tools.

SGTR/L

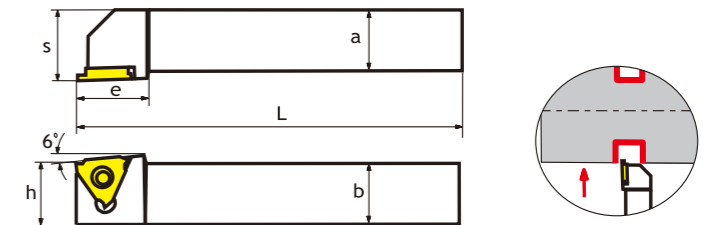

Type 型号	Dimension(mm) 基本尺寸								Applicable Inserts 使用的刀片	Clamping screw 螺钉	Wrench 扳手	
	Stock 库存		h	b	L ₁	L ₂	H _i	f				
	R	L										
SGTR/L	1212H16C			12	12	100	20	12	16	GLR/L3□□□□	M3.5 x 8	T15
	1616H16C			15	16	100	20	16	20			
	2020K16C			20	20	125	20	20	25			
	2525M16C			25	25	150	20	25	32			
	2020K22C			20	20	125	30	20	25			
	2525M22C			25	25	150	30	25	32			
										GLR/L4□□□□	M4 x 10	T15

★ 注明：配套刀片建议参考东芝刀片。Note:The insert is Toshiba brand.

KGBR/L

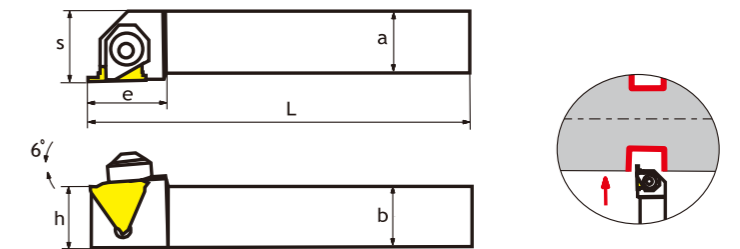

Type 型号	Dimension(mm) 基本尺寸								Applicable Inserts 使用的刀片	Clamping screw 螺钉	Clamp 压板	Wrench 扳手	
	Stock 库存		a	b	L	h	s	e					
	R	L											
KGBR/L	2020K22-15			20	20	125	20	25	24	GB43R/050-300	CM 0620	CGBR/L	S4
	2525M22-15			25	25	150	25	30	25				
	2020K22-25			20	20	125	20	25	25.5				
	2525M22-25			25	25	250	25	30	25.5				
	2020K22-35			20	20	125	20	25	25.5				
	2525M22-35			25	25	150	25	30	25.5				

★ 注明：配套刀片建议参考京瓷刀片。Note:The insert is Kyocera brand.

端面切槽、车削刀具 Surface Grooving and Turning Tools

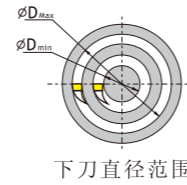
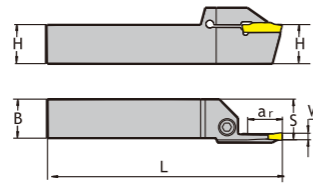

下刀直径范围

Type 型号	基本尺寸 Dimension(mm)						适用刀片 Applicable inserts	螺钉 Screw	扳手 Wrench
	HxB	L	S	W	a _r	∅D (min-Max)			
QFFD2525R/L10-48H	25x25	150	26	3	10	48-66	ZTFD0303-MG	M6 x 20	S5
QFFD2525R/L17-48H	25x25	150	26	3	17	48-66	ZTFD0303-MG		
QFFD2525R/L10-60H	25x25	150	26	3	10	60-80	ZTFD0303-MG		
QFFD2525R/L17-60H	25x25	150	26	3	17	60-80	ZTFD0303-MG		
QFFD2525R/L10-74H	25x25	150	26	3	10	74-110	ZTFD0303-MG		
QFFD2525R/L17-74H	25x25	150	26	3	17	74-110	ZTFD0303-MG		
QFFD2525R/L10-100H	25x25	150	26	3	10	100-150	ZTFD0303-MG		
QFFD2525R/L17-100H	25x25	150	26	3	17	100-150	ZTFD0303-MG		
QFGD2525R/L13-52H	25x25	150	26	4	13	52-72	ZTGD0404-MG		
QFGD2525R/L22-52H	25x25	150	26	4	22	52-72	ZTGD0404-MG		
QFGD2525R/L13-64H	25x25	150	26	4	13	64-100	ZTGD0404-MG		
QFGD2525R/L22-64H	25x25	150	26	4	22	64-100	ZTGD0404-MG		
QFGD2525R/L13-90H	25x25	150	26	4	13	90-140	ZTGD0404-MG		
QFGD2525R/L22-90H	25x25	150	26	4	22	90-140	ZTGD0404-MG		
QFGD2525R/L13-130H	25x25	150	26	4	13	130-230	ZTGD0404-MG		
QFGD2525R/L22-130H	25x25	150	26	4	22	130-230	ZTGD0404-MG		
QFHD2525R/L13-58H	25x25	150	26	5	13	58-96	ZTHD0504-MG		
QFHD2525R/L22-58H	25x25	150	26	5	22	58-96	ZTHD0504-MG		
QFHD2525R/L13-86H	25x25	150	26	5	13	86-140	ZTHD0504-MG		
QFHD2525R/L22-86H	25x25	150	26	5	22	86-140	ZTHD0504-MG		
QFHD2525R/L13-130H	25x25	150	26	5	13	130-200	ZTHD0504-MG		
QFHD2525R/L22-130H	25x25	150	26	5	22	130-200	ZTHD0504-MG		
QFHD2525R/L13-185H	25x25	150	26	5	13	185-400	ZTHD0504-MG		
QFHD2525R/L22-185H	25x25	150	26	5	22	185-400	ZTHD0504-MG		
QFHS2525R/L30-185H	25x25	150	26	5	30	185-400	ZTHS0504-MG		
QFKD2525R/L13-60H	25x25	150	26	6	13	60-100	ZTKD0608-MG		
QFKD2525R/L22-60H	25x25	150	26	6	22	60-100	ZTKD0608-MG		
QFKD2525R/L13-88H	25x25	150	26	6	13	88-180	ZTKD0608-MG		
QFKD2525R/L22-88H	25x25	150	26	6	22	88-180	ZTKD0608-MG		
QFKD2525R/L13-160H	25x25	150	26	6	13	160-400	ZTKD0608-MG		
QFKD2525R/L22-160H	25x25	150	26	6	22	160-400	ZTKD0608-MG		
QFKS2525R/L30-160H	25x25	150	26	6	30	160-400	ZTKS0608-MG		

★注明：配套刀片建议参考株洲刀片。Note:The insert is Zccct brand.

端面切槽、车削刀具 Surface Grooving and Turning Tools

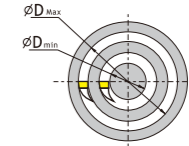
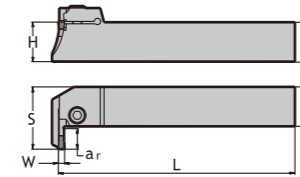

下刀直径范围

Type 型号	基本尺寸 Dimension(mm)						适用刀片 Applicable inserts	螺钉 Screw	扳手 Wrench
	HxB	L	S	W	a _r	∅D (min-Max)			
QFFD2525R/L10-48L	25x25	150	36.5	3	10	48-66	ZTFD0303-MG	M6 x 20	S5
QFFD2525R/L17-48L	25x25	150	43.5	3	17	48-66	ZTFD0303-MG		
QFFD2525R/L10-60L	25x25	150	36.5	3	10	60-80	ZTFD0303-MG		
QFFD2525R/L17-60L	25x25	150	43.5	3	17	60-80	ZTFD0303-MG		
QFFD2525R/L10-74L	25x25	150	36.5	3	10	74-110	ZTFD0303-MG		
QFFD2525R/L17-74L	25x25	150	43.5	3	17	74-110	ZTFD0303-MG		
QFFD2525R/L10-100L	25x25	150	36.5	3	10	100-150	ZTFD0303-MG		
QFFD2525R/L17-100L	25x25	150	43.5	3	17	100-150	ZTFD0303-MG		
QFGD2525R/L13-52L	25x25	150	39.5	4	13	52-72	ZTGD0404-MG		
QFGD2525R/L22-52L	25x25	150	48.5	4	22	52-72	ZTGD0404-MG		
QFGD2525R/L13-64L	25x25	150	39.5	4	13	64-100	ZTGD0404-MG		
QFGD2525R/L22-64L	25x25	150	48.5	4	22	64-100	ZTGD0404-MG		
QFGD2525R/L13-90L	25x25	150	39.5	4	13	90-140	ZTGD0404-MG		
QFGD2525R/L22-90L	25x25	150	48.5	4	22	90-140	ZTGD0404-MG		
QFGD2525R/L13-130L	25x25	150	39.5	4	13	130-230	ZTGD0404-MG		
QFGD2525R/L22-130L	25x25	150	48.5	4	22	130-230	ZTGD0404-MG		
QFHD2525R/L13-58L	25x25	150	39.5	5	13	58-96	ZTHD0504-MG		
QFHD2525R/L22-58L	25x25	150	48.5	5	22	58-96	ZTHD0504-MG		
QFHD2525R/L13-86L	25x25	150	39.5	5	13	86-140	ZTHD0504-MG		
QFHD2525R/L22-86L	25x25	150	48.5	5	22	86-140	ZTHD0504-MG		
QFHD2525R/L13-130L	25x25	150	39.5	5	13	130-200	ZTHD0504-MG		
QFHD2525R/L22-130L	25x25	150	48.5	5	22	130-200	ZTHD0504-MG		
QFHD2525R/L13-185L	25x25	150	39.5	5	13	185-400	ZTHD0504-MG		
QFHD2525R/L22-185L	25x25	150	48.5	5	22	185-400	ZTHD0504-MG		
QFHS2525R/L30-185L	25x25	150	56.5	5	30	185-400	ZTHS0504-MG		
QFKD2525R/L13-60L	25x25	150	39.5	6	13	60-100	ZTKD0608-MG		
QFKD2525R/L22-60L	25x25	150	48.5	6	22	60-100	ZTKD0608-MG		
QFKD2525R/L13-88L	25x25	150	39.5	6	13	88-180	ZTKD0608-MG		
QFKD2525R/L22-88L	25x25	150	48.5	6	22	88-180	ZTKD0608-MG		
QFKD2525R/L13-160L	25x25	150	39.5	6	13	160-400	ZTKD0608-MG		
QFKD2525R/L22-160L	25x25	150	48.5	6	22	160-400	ZTKD0608-MG		
QFKS2525R/L30-160L	25x25	150	56.5	6	30	160-400	ZTKS0608-MG		

车削刀具 | TURNING TOOLS



切断切槽刀 Parting and grooving toolholders

QF□D-RR

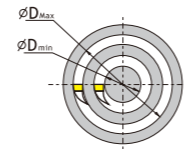
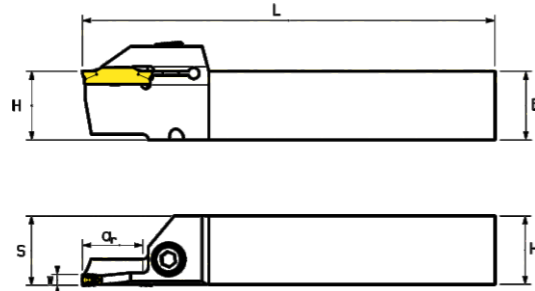

下刀直径范围

Type 型号	基本尺寸 Dimension(mm)						适用刀片 Applicable inserts	螺钉 Screw	扳手 Wrench
	HxB	L	S	W	a _r	∅D (min-Max)			
QFFD2525RR10-48H	25x25	150	26	3	10	48-66	ZTFD0303-MG	M6 × 20	S5
QFFD2525RR17-48H	25x25	150	26	3	17	48-66	ZTFD0303-MG		
QFFD2525RR10-60H	25x25	150	26	3	10	60-80	ZTFD0303-MG		
QFFD2525RR17-60H	25x25	150	26	3	17	60-80	ZTFD0303-MG		
QFFD2525RR10-74H	25x25	150	26	3	10	74-110	ZTFD0303-MG		
QFFD2525RR17-74H	25x25	150	26	3	17	74-110	ZTFD0303-MG		
QFFD2525RR10-100H	25x25	150	26	3	10	100-150	ZTFD0303-MG		
QFFD2525RR17-100H	25x25	150	26	3	17	100-150	ZTFD0303-MG		
QFGD2525RR13-52H	25x25	150	26	4	13	52-72	ZTGD0404-MG		
QFGD2525RR 22-52H	25x25	150	26	4	22	52-72	ZTGD0404-MG		
QFGD2525RR13-64H	25x25	150	26	4	13	64-100	ZTGD0404-MG		
QFGD2525RR 22-64H	25x25	150	26	4	22	64-100	ZTGD0404-MG		
QFGD2525RR13-90H	25x25	150	26	4	13	90-140	ZTGD0404-MG		
QFGD2525RR 22-90H	25x25	150	26	4	22	90-140	ZTGD0404-MG		
QFGD2525RR13-130H	25x25	150	26	4	13	130-230	ZTGD0404-MG		
QFGD2525RR22-130H	25x25	150	26	4	22	130-230	ZTGD0404-MG		
QFHD2525RR13-58H	25x25	150	26	5	13	58-96	ZTHD0504-MG		
QFHD2525RR 22-58H	25x25	150	26	5	22	58-96	ZTHD0504-MG		
QFHD2525RR 13-86H	25x25	150	26	5	13	86-140	ZTHD0504-MG		
QFHD2525RR 22-86H	25x25	150	26	5	22	86-140	ZTHD0504-MG		
QFHD2525RR 13-130H	25x25	150	26	5	13	130-200	ZTHD0504-MG		
QFHD2525RR 22-130H	25x25	150	26	5	22	130-200	ZTHD0504-MG		
QFHD2525RR 13-185H	25x25	150	26	5	13	185-400	ZTHD0504-MG		
QFHD2525RR 22-185H	25x25	150	26	5	22	185-400	ZTHD0504-MG		
QFHS2525RR 30-185H	25x25	150	26	5	30	185-400	ZTHS0504-MG		
QFKD2525RR 13-60H	25x25	150	26	6	13	60-100	ZTKD0608-MG		
QFKD2525RR22-60H	25x25	150	26	6	22	60-100	ZTKD0608-MG		
QFKD2525RR 13-88H	25x25	150	26	6	13	88-180	ZTKD0608-MG		
QFKD2525RR 22-88H	25x25	150	26	6	22	88-180	ZTKD0608-MG		
QFKD2525RR 13-160H	25x25	150	26	6	13	160-400	ZTKD0608-MG		
QFKD2525RR 22-160H	25x25	150	26	6	22	160-400	ZTKD0608-MG		
QFKS2525RR 30-160H	25x25	150	26	6	30	160-400	ZTKS0608-MG		

了解具体库存情况请致电厂家 详情请登陆网站www.hnsant.com

车削刀具 | TURNING TOOLS



Parting and grooving toolholders 切断切槽刀

QF□D-LL

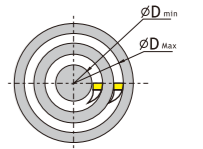
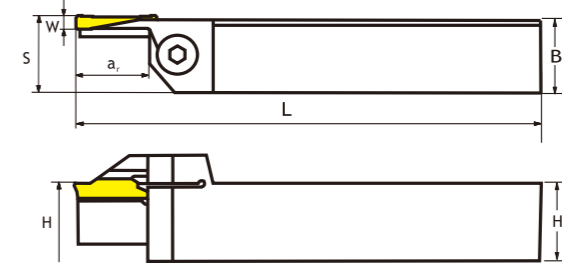

下刀直径范围

Type 型号	基本尺寸 Dimension(mm)						适用刀片 Applicable inserts	螺钉 Screw	扳手 Wrench
	HxB	L	S	W	a _r	∅D (min-Max)			
QFFD2525LL10-48H	25x25	150	26	3	10	48-66	ZTFD0303-MG	M6 × 20	S5
QFFD2525LL17-48H	25x25	150	26	3	17	48-66	ZTFD0303-MG		
QFFD2525LL10-60H	25x25	150	26	3	10	60-80	ZTFD0303-MG		
QFFD2525LL17-60H	25x25	150	26	3	17	60-80	ZTFD0303-MG		
QFFD2525LL10-74H	25x25	150	26	3	10	74-110	ZTFD0303-MG		
QFFD2525LL17-74H	25x25	150	26	3	17	74-110	ZTFD0303-MG		
QFFD2525LL10-100H	25x25	150	26	3	10	100-150	ZTFD0303-MG		
QFFD2525LL17-100H	25x25	150	26	3	17	100-150	ZTFD0303-MG		
QFGD2525LL13-52H	25x25	150	26	4	13	52-72	ZTGD0404-MG		
QFGD2525LL 22-52H	25x25	150	26	4	22	52-72	ZTGD0404-MG		
QFGD2525LL13-64H	25x25	150	26	4	13	64-100	ZTGD0404-MG		
QFGD2525LL 22-64H	25x25	150	26	4	22	64-100	ZTGD0404-MG		
QFGD2525LL13-90H	25x25	150	26	4	13	90-140	ZTGD0404-MG		
QFGD2525LL 22-90H	25x25	150	26	4	22	90-140	ZTGD0404-MG		
QFGD2525LL13-130H	25x25	150	26	4	13	130-230	ZTGD0404-MG		
QFGD2525LL22-130H	25x25	150	26	4	22	130-230	ZTGD0404-MG		
QFHD2525LL13-58H	25x25	150	26	5	13	58-96	ZTHD0504-MG		
QFHD2525LL 22-58H	25x25	150	26	5	22	58-96	ZTHD0504-MG		
QFHD2525LL 13-86H	25x25	150	26	5	13	86-140	ZTHD0504-MG		
QFHD2525LL 22-86H	25x25	150	26	5	22	86-140	ZTHD0504-MG		
QFHD2525LL 13-130H	25x25	150	26	5	13	130-200	ZTHD0504-MG		
QFHD2525LL22-130H	25x25	150	26	5	22	130-200	ZTHD0504-MG		
QFHD2525LL13-185H	25x25	150	26	5	13	185-400	ZTHD0504-MG		
QFHD2525LL22-185H	25x25	150	26	5	22	185-400	ZTHD0504-MG		
QFHS2525LL30-185H	25x25	150	26	5	30	185-400	ZTHS0504-MG		
QFKD2525LL 13-60H	25x25	150	26	6	13	60-100	ZTKD0608-MG		
QFKD2525LL22-60H	25x25	150	26	6	22	60-100	ZTKD0608-MG		
QFKD2525LL13-88H	25x25	150	26	6	13	88-180	ZTKD0608-MG		
QFKD2525LL 22-88H	25x25	150	26	6	22	88-180	ZTKD0608-MG		
QFKD2525LL 13-160H	25x25	150	26	6	13	160-400	ZTKD0608-MG		
QFKD2525LL 22-160H	25x25	150	26	6	22	160-400	ZTKD0608-MG		
QFKS2525LL 30-160H	25x25	150	26	6	30	160-400	ZTKS0608-MG		

了解具体库存情况请致电厂家 详情请登陆网站www.hnsant.com

ZQ

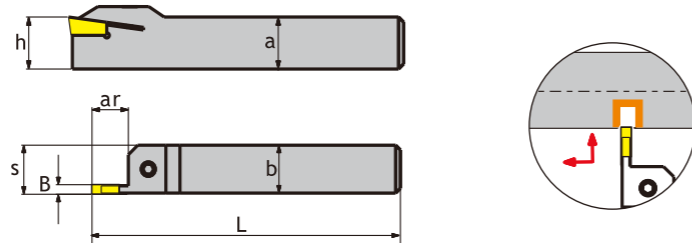
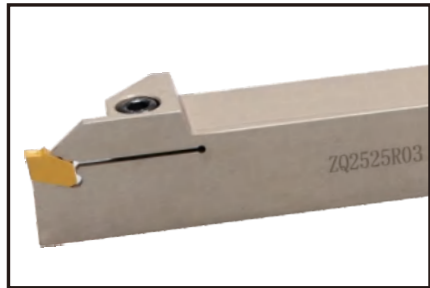

Type 型号	Dimension(mm) 基本尺寸							Applicable Inserts 使用的刀片	Screw 螺钉	Wrench 扳手	
	Stock 库存	h	b	L	S	B	a _{r,max}				
ZQ	1616R03		16	16	100	16.4	3	16	ZQMX3N11-IE	M5x17	S4
	1616R04		16	16	100	16.4	4	18	ZQMX4N11-IE		
	2020R03		20	20	125	20.4	3	20	ZQMX3N11-IE		
	2020R04		20	20	125	20.4	4	20	ZQMX4N11-IE	M6x20	S5
	2525R03		25	25	150	25.4	3	20	ZQMX3N11-IE		
	2525R04		25	25	150	25.4	4	20	ZQMX4N11-IE		
	2525R05		25	25	150	25.4	5	25	ZQMX5N11-IE	M6x22	S5
	2525R06		25	25	150	25.7	6	32	ZQMX6N11-IE		
	3225R03		32	25	170	25.4	3	25	ZQMX3N11-IE		
	3225R04		32	25	170	25.4	4	25	ZQMX4N11-IE	M6x22	S5
	3225R05		32	25	170	25.4	5	25	ZQMX5N11-IE		
	3225R06		32	25	170	25.7	6	32	ZQMX6N11-IE		
ZQ	1616L03		16	16	100	16.4	3	16	ZQMX3N11-IE	M5x17	S4
	1616L04		16	16	100	16.4	4	16	ZQMX4N11-IE		
	2020L03		20	20	125	20.4	3	20	ZQMX3N11-IE		
	2020L04		20	20	125	20.4	4	20	ZQMX4N11-IE	M6x20	S5
	2525L03		25	25	150	25.4	3	20	ZQMX3N11-IE		
	2525L04		25	25	150	25.4	4	20	ZQMX4N11-IE		
	2525L05		25	25	150	25.4	5	25	ZQMX5N11-IE	M6x22	S5
	2525L06		25	25	150	25.7	6	32	ZQMX6N11-IE		
	3225L03		32	25	170	25.4	3	25	ZQMX3N11-IE		
	3225L04		32	25	170	25.4	4	25	ZQMX4N11-IE	M6x22	S5
	3225L05		32	25	170	25.4	5	25	ZQMX5N11-IE		
	3225L06		32	25	170	25.7	6	32	ZQMX6N11-IE		

外圆切断的刀板 External Parting Blade

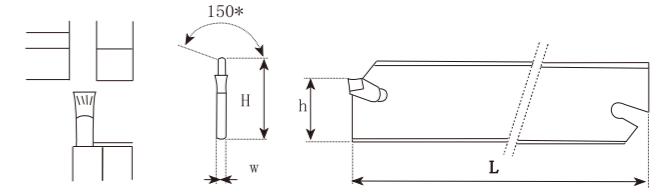

参考 注释	刀杆形状	适用条件				适用刀片	
		切断					
型号	库存	H	W	L	h		
SPB	326-S		26	2.4	110	21.6	ZQMX3N11-IE
	426-S		26	3.2	110	21.6	ZQMX4N11-IE
	526-S		26	4.0	110	21.6	ZQMX5N11-IE
	626-S		26	5.2	110	21.6	ZQMX6N11-IE
	332-S		32	2.4	150	25	ZQMX3N11-IE
	432-S		32	3.2	150	25	ZQMX4N11-IE
	532-S		32	4.0	150	25	ZQMX5N11-IE
	632-S		32	5.2	150	25	ZQMX6N11-IE

SPB系列刀板需要配套SANT圣达公司PHS系列刀座 SPB parting blade is matching with PHS parting blade holder from SANT.

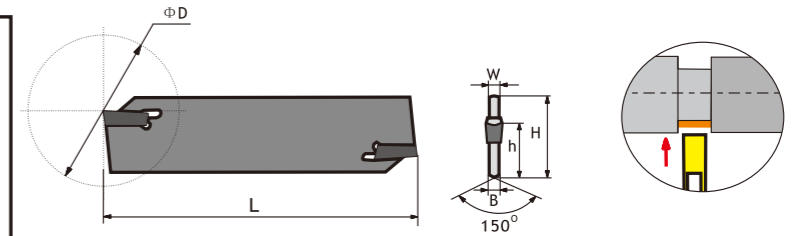

Type 型号	Dimension(mm) 基本尺寸							Applicable Inserts 使用的刀片	Wrench 配套扳手		
	Stock 库存	R	L	L	H	h	B			W	ΦD _{max}
QEE S26N				110	26	19	2	2.5	60	ZPES02502-MG	QS5
QEFS26N				110	26	19	2.4	3	60	ZPFS0302-MG	QS5
QEGS26N				110	26	19	3.2	4	70	ZPGS0402-MG	QS5
QEHS26N				110	26	19	4	5	70	ZPHS0503-MG	QS5
QEKS26N				110	26	19	5	6	70	ZPKS0604-MG	QS5
QEE S32N				150	32	24.6	2	2.5	100	ZPES02502-MG	QS5
QEFS32N				150	32	24.6	2.4	3	100	ZPFS0302-MG	QS5
QEGS32N				150	32	24.6	3.2	4	120	ZPGS0402-MG	QS5
QEHS32N				150	32	24.6	4	5	120	ZPHS0503-MG	QS5
QEKS32N				150	32	24.6	5	6	120	ZPKS0604-MG	QS5

QE□S系列刀板需要配套SANT圣达公司QZS系列刀座 QE□S parting blade is matching with QZS parting blade holder from SANT.

内圆切槽及车削刀具

Internal Grooving and Turning Tools

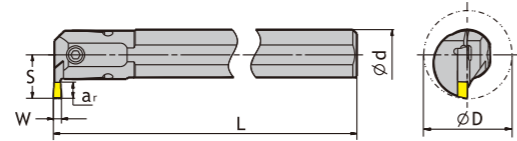

Type 型号	基本尺寸 Dimension(mm)						适用刀片 Applicable inserts	螺钉 Screw	扳手 Wrench
	∅d	L	S	W	最大切深 a _{r,max}	∅D (最小加工直径)			
C20Q-QEDR/L 05-27	20	180	15.2	2.5	5	27	ZTED*****	M4 × 14	S3
C25R-QEDR/L 07-33	25	200	20.3	2.5	7	33		M5 × 17	S4
C32S-QEDR/L 09-42	32	250	25.3	2.5	9	42	ZRED*****	M4 × 14	S3
C20Q-QFDR/L 05-27	20	180	15.2	3	5	27	ZTFD*****		S4
C25R-QFDR/L 07-33	25	200	20.3	3	7	33	ZRFD*****	M5 × 17	S4
C32S-QFDR/L 09-42	32	250	25.3	3	9	42	ZTGD*****	M6 × 20	S5
C25R-QGDR/L 08-35	25	200	21.5	4	8	35	ZRHD*****		S4
C32S-QGDR/L 11-44	32	250	27.5	4	11	44	ZTHD*****	M5 × 17	S4
C40T-QGDR/L 13-54	40	300	33.5	4	13	54	ZTKD*****		S5
C25R-QHDR/L 08-35	25	200	21.5	5	8	35	ZRHD*****	M5 × 17	S4
C32S-QHDR/L 11-44	32	250	27.5	5	11	44	ZRHD*****		S5
C40T-QHDR/L 13-54	40	300	33.5	5	13	54	ZTKD*****	M5 × 17	S4
C25R-QKDR/L 08-35	25	200	21.5	6	8	35	ZRHD*****		S4
C32S-QKDR/L 11-44	32	250	27.5	6	11	44	ZRHD*****	M5 × 17	S4
C40T-QKDR/L 13-54	40	300	33.5	6	13	54	ZRHD*****		S4
C50T-QKDR/L13-64	50	300	38.1	6	14	64	ZRHD*****	M6 × 20	S5

内圆切槽及车削刀具

Internal Grooving and Turning Tools

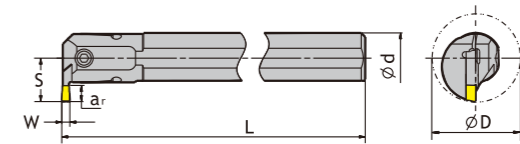

Type 型号	基本尺寸 Dimension(mm)						刀片 Inserts	螺钉 Screw	扳手 Wrench
	∅d	L	S	W	最大切深 a _{r,max}	∅D			
MGIVR/L	2016-1.5	16	180	11.3	1.5	3	MGMN150-M	M4 × 14	S3
	2520-1.5	20	180	13.1	1.5	4	MGMN150-M	M5 × 17	S4
	2925-1.5	25	200	16.2	1.5	4	MGMN150-M	M5 × 17	S4
	2016-2	16	125	12.4	2	3	MGMN200-M	M4 × 14	S3
	2520-2	20	125	14	2	5	MGMN200-M	M5 × 17	S4
	2925-2	25	200	17.2	2	5	MGMN200-M	M5 × 17	S4
	2016-2.5	16	125	12.5	2.5	6	MGMN250-M	M4 × 14	S3
	2520-2.5	20	180	15.1	2.5	6	MGMN250-M	M5 × 17	S4
	2925-2.5	25	200	18.2	2.5	6	MGMN250-M	M5 × 17	S4
	2520-3	20	180	15.6	3	6	MGMN300-M	M5 × 17	S4
	3125-3	25	200	18.9	3	5	MGMN300-M	M5 × 17	S4
	3732-3	32	250	21.5	3	6	MGMN300-M	M5 × 20	S4
	2520-4	20	180	15.6	4	6	MGMN400-M	M5 × 17	S4
	3125-4	25	200	18.9	4	6	MGMN400-M	M5 × 17	S4
	3732-4	32	250	21.5	4	6	MGMN400-M	M5 × 20	S4
	3125-5	25	200	19.1	5	8	MGMN500-M	M6 × 20	S5
	3732-5	32	250	21.5	5	8	MGMN500-M		
	3125-6	25	200	19.4	6	8	MGMN600-M		
	3732-6	32	250	21.5	6	8	MGMN600-M		
	3732-8	32	250	23.2	8	10	MGMN800-M		
4540-8	40	300	27.2	8	10	MGMN800-M			
3125-6A	25	200	19.4	6	8	MGMN600-M			
3732-6A	32	250	21.5	6	8	MGMN600-M			
3732-8A	32	250	23.4	8	10	MGMN800-M			
4540-8A	40	300	27.2	8	10	MGMN800-M			

★ 可安装切断、切槽、车削、仿形刀片。(配套韩国克洛依刀片) Note:The insert is Korloy brand.
Parting, grooving, turning, profiling inserts are adaptable to the tools.

★ 小松鼠系列槽刀刀片选择 Matching Insert

型号 Type	SD2136	SD2336	SD4326	SD4226	SD4236	SD5346	SD5236	SD5450	SD5440	SD5146	基本尺寸(mm) Dimension		
											W	R	最大切深 La max
ZTED02503-MG	●	●	●				●	○			2.5	0.3	17
ZTFD0303-MG	●	●	●				●	○			3	0.3	17
ZTHD0404-MG	●	●	●				●	○			4	0.4	22
ZTHD0504-MG	●	●	●				●	○			5	0.4	22
ZTKD0608-MG	●	●	●				●	○			6	0.8	22
ZTHS0504-MG	○	○	○								5	0.4	-
ZTKS0608-MG	○	○	○								6	0.8	-
P 钢	■	■					■	■					
M 不锈钢	□	■											
K 铸铁		■	■										
N 有色金属													
S 耐热合金、钛合金		■											
H 淬硬材料													

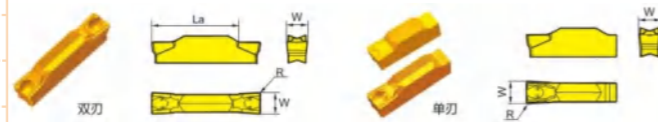

● 常备库存 Unallocated stock ○ 可备库存 Available stock ■ 推荐应用 Main application □ 拓展应用 Extended application

★ 克洛伊系列槽刀刀片选择 Matching Insert

型号 Type	SD2136	SD2336	SD4326	SD4226	SD4236	SD5346	SD5236	SD5450	SD5440	SD5146	基本尺寸(mm) Dimension				
											b	r	l	d	t
MGMN200-M	●	●	●				●	○			2	0.2	16	1.2	3.5
MGMN250-M	●	●	●				●	○			2.5	0.2	18.5	2	3.85
MGMN300-M	●	●	●				●	○			3	0.4	21	2.35	4.8
MGMN400-M	●	●	●				●	○			4	0.4	21	3.3	4.8
MGMN500-M	●	●	●				●	○			5	0.8	26	4.1	5.8
MGMN600-M	●	●	●				●	○			6	0.8	26	5	5.8
P 钢	■	■					■	■							
M 不锈钢	□	■													
K 铸铁		■	■												
N 有色金属															
S 耐热合金、钛合金		■													
H 淬硬材料															

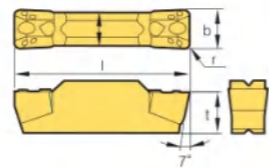

● 常备库存 Unallocated stock ○ 可备库存 Available stock ■ 推荐应用 Main application □ 拓展应用 Extended application

用于外圆切断刀板的刀座 Parting Blade Holders

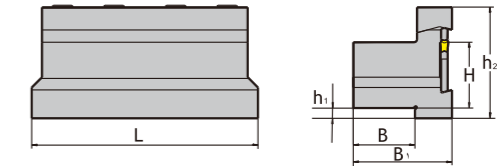

Type 型号	基本尺寸 Dimension(mm)						上压板 clamp	螺钉 Screw	扳手 Wrench
	L	H	h1	h2	B	B1			
PHS2026	86	20	10	46.6	19	38	PHS26	M6 × 20	S5
PHS2526	86	25	5	46.6	23	42			
PHS3226	86	32	3	51.6	30	48			
PHS2032	110	20	13	50	19	38			
PHS2532	110	25	8	50	23	42			
PHS3232	110	32	5	54	30	48			

此刀座用于SPB系列刀板 This parting blade holder is for SPB parting blades.

数控车削刀具加工示意图

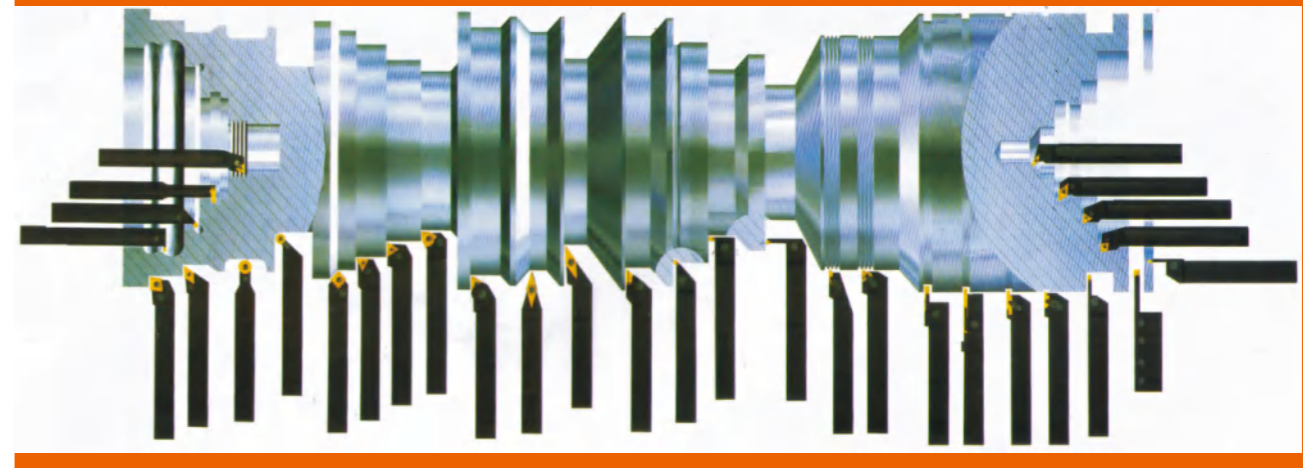

SIGER内孔切槽刀杆 Internal Grooving and Turning Tools

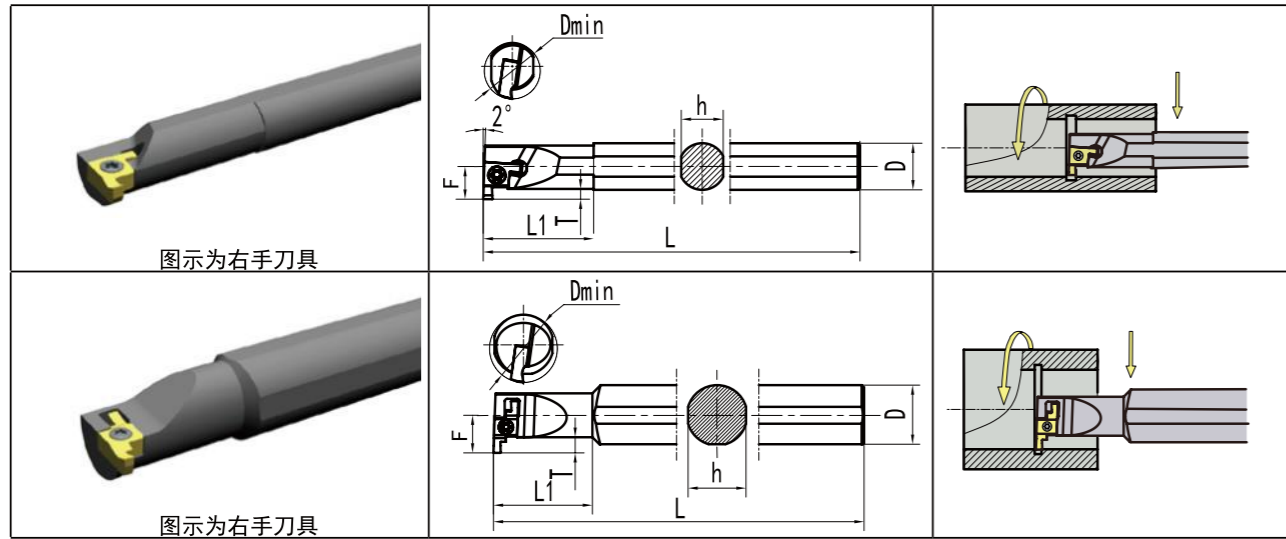

刀杆型号 Toolholder Type	刀片型号 Insert Type	最小加工直径 Dmin	尺寸 Dimensions (mm)						刀片螺钉 Insert Screw	扳手 Torx Key	
			T	L1	D	F	h	L			
SIGER	0808A	GER**-A GER**-AR	8	1.5	20	8	4.8	7.2	100	L60M2. 2x5	T06
	1010B	GER**-B GER**-BR	10	2.2	25	10	6.2	9	125	L60M2. 5*7	T08
	1210B		12		30	10	7	9	125		
	1412C	GER**-C GER**-CR	14	2.5	33	12	8	11.4	150	L60M2. 5*7	T08
	1612C		16		20	12	8.5	11.4	150		
	1616C		16		36	16	9	15	160		
	2020D	GER**-D GER**-DR	20	4.5	40	20	12.1	19	180	L60M3*8	T10
	2525D		25		45	25	12.3	24	200		
	2525E	GER**-E GER**-ER	25	6.5	45	25	15.6	24	200	L60M4*8. 5	T15
	3232E		32		55	32	19	30.4	220		
4032E	40		-		32	23	30.4	250			
SIGEL	0808A	GEL**-A GEL**-AR	8	1.5	20	8	4.8	7.2	100	L60M2. 2x5	T06
	1010B	GEL**-B GEL**-BR	10	2.2	25	10	6.2	9	125	L60M2. 5*7	T08
	1210B		12		30	10	7	9	125		
	1412C	GEL**-C GEL**-CR	14	2.5	33	12	8	11.4	150	L60M2. 5*7	T08
	1612C		16		20	12	8.5	11.4	150		
	1616C		16		36	16	9	15	160		
	2020D	GEL**-D GEL**-DR	20	4.5	40	20	12.1	19	180	L60M3*8	T10
	2525D		25		45	25	12.3	24	200		
	2525E	GEL**-E GEL**-ER	25	6.5	45	25	15.6	24	200	L60M4*8. 5	T15
	3232E		32		55	32	19	30.4	220		
	4032E		40		-	32	23	30.4	250		

GER系列内孔切槽刀片 Internal Grooving and Turning Tools

型号 Model	A (mm)	L (mm)	T (mm)	d (mm)	推荐		材料推荐 material recommended	PM125	DK110	A、B系列刀片式样 A, B series insert styles	
					☺ 优先推荐 Good recommendation	☹ 一般推荐 General recommendation					
GER**-A	6.69	6.5	2.58	2.5	☺	☹	钢件 P	☺	☹	A、B系列刀片式样 A, B series insert styles	
GER**-B	8.46	8.2	3.18	2.7	☺	☹	不锈钢 M	☺	☹		
GER**-C	5.8	11.48	4.05	2.8	☺	☹	铸铁 K	☺	☹		
GER**-D	6.8	16.44	5.05	3.4	☺	☹	有色金属 N	☺	☹		
GER**-E	9.54	21.66	5.55	4.4	☺	☹		☺	☹		
刀片 Insert	右手刀片 Right hand		左手刀片 Left hand		槽宽 W	切深 B	圆弧 r	PM125 R L R L		DK110 R L R L	配套刀杆 Toolholders
	GER050-A	GEL050-A	0.5	1.2	0.05	●	○	○	○	○	右手刀片配右刀杆 SIGER0808A
	GER060-A	GEL060-A	0.6	1.2	0.05	●	○	○	○	○	
	GER070-A	GEL070-A	0.7	1.2	0.05	●	○	○	○	○	
	GER080-A	GEL080-A	0.8	1.2	0.05	●	○	○	○	○	
	GER100-A	GEL100-A	1.0	1.5	0.05	●	○	○	○	○	
	GER120-A	GEL120-A	1.2	1.5	0.05	●	○	○	○	○	
	GER125-A	GEL125-A	1.25	1.5	0.05	●	○	○	○	○	
	GER140-A	GEL140-A	1.4	1.5	0.1	●	○	○	○	○	
	GER150-A	GEL150-A	1.5	1.5	0.1	●	○	○	○	○	
	GER180-A	GEL180-A	1.8	1.5	0.1	●	○	○	○	○	
	GER080-B	GEL080-B	0.8	1.8	0.05	●	○	○	○	○	右手刀片配右刀杆 SIGER1010B SIGER1210B
	GER100-B	GEL100-B	1.0	2.2	0.05	●	○	○	○	○	
	GER120-B	GEL120-B	1.2	2.2	0.05	●	○	○	○	○	
	GER125-B	GEL125-B	1.25	2.2	0.05	●	○	○	○	○	
	GER130-B	GEL130-B	1.3	2.2	0.1	●	○	○	○	○	
	GER145-B	GEL145-B	1.45	2.2	0.1	●	○	○	○	○	
	GER150-B	GEL150-B	1.5	2.2	0.1	●	○	○	○	○	
	GER180-B	GEL180-B	1.8	2.2	0.1	●	○	○	○	○	
	GER200-B	GEL200-B	2.0	2.2	0.1	●	○	○	○	○	
	GER225-B	GEL225-B	2.25	2.2	0.1	●	○	○	○	○	
	GER250-B	GEL250-B	2.5	2.2	0.1	●	○	○	○	○	右手刀片配右刀杆 SIGER1412C SIGER1612C SIGER1616C
	GER280-B	GEL280-B	2.8	2.2	0.2	●	○	○	○	○	
	GER300-B	GEL300-B	3.0	2.2	0.2	●	○	○	○	○	
	GER100-C	GEL100-C	1.0	2.5	0.05	●	○	○	○	○	
	GER120-C	GEL120-C	1.2	2.5	0.05	●	○	○	○	○	
	GER125-C	GEL125-C	1.25	2.5	0.05	●	○	○	○	○	
	GER140-C	GEL140-C	1.4	2.5	0.1	●	○	○	○	○	
	GER145-C	GEL145-C	1.45	2.5	0.1	●	○	○	○	○	
	GER150-C	GEL150-C	1.5	2.5	0.1	●	○	○	○	○	
	GER160-C	GEL160-C	1.6	2.5	0.1	●	○	○	○	○	
	GER170-C	GEL170-C	1.7	2.5	0.1	●	○	○	○	○	
	GER185-C	GEL185-C	1.85	2.5	0.1	●	○	○	○	○	
	GER195-C	GEL195-C	1.95	2.5	0.1	●	○	○	○	○	
	GER200-C	GEL200-C	2.0	2.5	0.1	●	○	○	○	○	
	GER225-C	GEL225-C	2.25	2.5	0.1	●	○	○	○	○	
GER250-C	GEL250-C	2.5	2.5	0.2	●	○	○	○	○		
GER275-C	GEL275-C	2.75	2.5	0.2	●	○	○	○	○		
GER280-C	GEL280-C	2.8	2.5	0.2	●	○	○	○	○		
GER300-C	GEL300-C	3.0	2.5	0.2	●	○	○	○	○		
GER320-C	GEL320-C	3.2	2.5	0.2	●	○	○	○	○		
GER350-C	GEL350-C	3.5	2.5	0.2	●	○	○	○	○		

GER系列内孔切槽刀片 Internal Grooving and Turning Tools

型号 Model	A (mm)	L (mm)	T (mm)	d (mm)	☺ 优先推荐 Good recommendation	☹ 一般推荐 General recommendation	材质推荐 material recommended		C、D、E 系列刀片式样	
GER**A	6.69	6.5	2.58	2.5	☺	☹	钢件 P	☺	<p>C、D、E 系列刀片式样</p>	
GER**B	8.46	8.2	3.18	2.7	☺	☹	不锈钢 M	☺		
GER**C	5.8	11.48	4.05	2.8	☺	☹	铸铁 K	☹		
GER**D	6.8	16.44	5.05	3.4	☺	☹	有色金属 N	☺		
GER**E	9.54	21.66	5.55	4.4	☺	☹				

刀片 Insert	右手刀片 Right hand	左手刀片 Left hand	槽宽		圆弧	PM125		DK110		配套刀杆 Toolholders
			W	B		R	L	R	L	
	GER100-D	GEL100-D	1.0	2.5	0.05	●	○	○	○	右手刀片配右刀杆 SIGER2020D SIGER2525D
	GER120-D	GEL120-D	1.2	2.5	0.05	●	○	○	○	
	GER125-D	GEL125-D	1.25	2.5	0.05	●	○	○	○	
	GER140-D	GEL140-D	1.4	2.5	0.05	●	○	○	○	
	GER145-D	GEL145-D	1.45	2.5	0.1	●	○	○	○	
	GER150-D	GEL150-D	1.5	3.0	0.1	●	○	○	○	
	GER170-D	GEL170-D	1.7	3.0	0.1	●	○	○	○	
	GER185-D	GEL185-D	1.85	3.0	0.1	●	○	○	○	
	GER195-D	GEL195-D	1.95	3.0	0.1	●	○	○	○	
	GER200-D	GEL200-D	2.0	3.6	0.1	●	○	○	○	
	GER225-D	GEL225-D	2.25	3.6	0.1	●	○	○	○	
	GER230-D	GEL230-D	2.3	3.6	0.2	●	○	○	○	
	GER250-D	GEL250-D	2.5	3.6	0.2	●	○	○	○	
	GER275-D	GEL275-D	2.75	3.6	0.2	●	○	○	○	
	GER280-D	GEL280-D	2.8	4.5	0.2	●	○	○	○	
	GER300-D	GEL300-D	3.0	4.5	0.2	●	○	○	○	
	GER320-D	GEL320-D	3.2	4.5	0.2	●	○	○	○	
	GER350-D	GEL350-D	3.5	4.5	0.2	●	○	○	○	
	GER400-D	GEL400-D	4.0	4.5	0.2	●	○	○	○	
		GER100-E	GEL100-E	1.0	3.0	0.05	●	○	○	○
GER150-E		GEL150-E	1.5	3.5	0.1	●	○	○	○	
GER170-E		GEL170-E	1.7	3.5	0.1	●	○	○	○	
GER185-E		GEL185-E	1.85	3.5	0.1	●	○	○	○	
GER195-E		GEL195-E	1.95	3.5	0.1	●	○	○	○	
GER200-E		GEL200-E	2.0	3.8	0.1	●	○	○	○	
GER225-E		GEL225-E	2.25	3.8	0.1	●	○	○	○	
GER230-E		GEL230-E	2.3	3.8	0.2	●	○	○	○	
GER250-E		GEL250-E	2.5	4.5	0.2	●	○	○	○	
GER275-E		GEL275-E	2.75	4.5	0.2	●	○	○	○	
GER280-E		GEL280-E	2.8	4.5	0.2	●	○	○	○	
GER300-E		GEL300-E	3.0	4.5	0.2	●	○	○	○	
GER330-E		GEL330-E	3.3	4.5	0.2	●	○	○	○	
GER350-E		GEL350-E	3.5	5.5	0.2	●	○	○	○	
GER400-E		GEL400-E	4.0	5.5	0.2	●	○	○	○	
GER430-E	GEL430-E	4.3	5.5	0.2	●	○	○	○		
GER450-E	GEL450-E	4.5	6.5	0.2	●	○	○	○		
GER460-E	GEL460-E	4.6	6.5	0.2	●	○	○	○		
GER500-E	GEL500-E	5.0	6.5	0.2	●	○	○	○		

● 常备库存 (主推) Standing stock ○ 非常备库存 Extraordinary stock

GER系列内孔切槽刀片 Internal Grooving and Turning Tools

型号 Model	A (mm)	L (mm)	T (mm)	d (mm)	☺ 优先推荐 Good recommendation	☹ 一般推荐 General recommendation	材质推荐 material recommended		图片式样见下图 See the following two pictures	
GER**A	6.69	6.5	2.58	2.5	☺	☹	钢件 P	☺	<p>图片式样见下图 See the following two pictures</p>	
GER**B	8.46	8.2	3.18	2.7	☺	☹	不锈钢 M	☺		
GER**C	5.8	11.48	4.05	2.8	☺	☹	铸铁 K	☹		
GER**D	6.8	16.44	5.05	3.4	☺	☹	有色金属 N	☺		
GER**E	9.54	21.66	5.55	4.4	☺	☹				

刀片 Insert	右手刀片 Right hand	左手刀片 Left hand	槽宽		圆弧	PM125		DK110		配套刀杆 Toolholders		
			W	B		R	L	R	L			
	GER100-050AR	GEL100-050AR	1.0	1.5	0.5	●	○	○	○	右手刀片配右刀杆 SIGER0808A		
	GER150-075AR	GEL150-075AR	1.5	1.5	0.75	●	○	○	○			
	GER200-100AR	GEL200-100AR	2.0	1.5	1	●	○	○	○			
		GER100-050BR	GEL100-050BR	1.0	2.2	0.5	●	○	○	○	右手刀片配右刀杆 SIGER1010B SIGER1210B	
		GER150-075BR	GEL150-075BR	1.5	2.2	0.75	●	○	○	○		
		GER200-100BR	GEL200-100BR	2.0	2.2	1	●	○	○	○		
		GER250-125BR	GEL250-125BR	2.5	2.2	1.25	●	○	○	○		
		GER300-150BR	GEL300-150BR	3.0	2.2	1.5	●	○	○	○		
			GER100-050CR	GEL100-050CR	1.0	2.5	0.5	●	○	○	○	右手刀片配右刀杆 SIGER1412C SIGER1612C SIGER1616C
			GER150-075CR	GEL150-075CR	1.5	2.5	0.75	●	○	○	○	
GER200-100CR			GEL200-100CR	2.0	2.5	1	●	○	○	○		
			GER250-125CR	GEL250-125CR	2.5	2.5	1.25	●	○	○	○	右手刀片配右刀杆 SIGER2020D SIGER2525D
			GER300-150CR	GEL300-150CR	3.0	2.5	1.5	●	○	○	○	
	GER150-075DR		GEL150-075DR	1.5	3.2	0.75	●	○	○	○		
	GER200-100DR		GEL200-100DR	2.0	3.2	1	●	○	○	○		
	GER250-125DR		GEL250-125DR	2.5	4.5	1.25	●	○	○	○		
	GER300-150DR		GEL300-150DR	3.0	4.5	1.5	●	○	○	○		
	GER250-125ER		GEL250-125ER	2.5	5.5	1.25	●	○	○	○		
	GER300-150ER	GEL300-150ER	3.0	5.5	1.5	●	○	○	○	右手刀片配右刀杆 SIGER2525E SIGER3232E SIGER4032E		
	GER350-175ER	GEL350-175ER	3.5	5.5	1.75	●	○	○	○			
	GER400-200ER	GEL400-200ER	4.0	6.5	2	●	○	○	○			
	GER450-225ER	GEL450-225ER	4.5	6.5	2.25	●	○	○	○			
	GER500-250ER	GEL500-250ER	5.0	6.5	2.5	●	○	○	○			

● 常备库存 (主推) Standing stock ○ 非常备库存 Extraordinary stock

