

## MODEL: 12C16A-3A

## NO.:301020003-00291

Container Color	
■	Cover:Black C
□	Bottom:White C

### Plane Chart:

Unit:mm Terminal type:G7

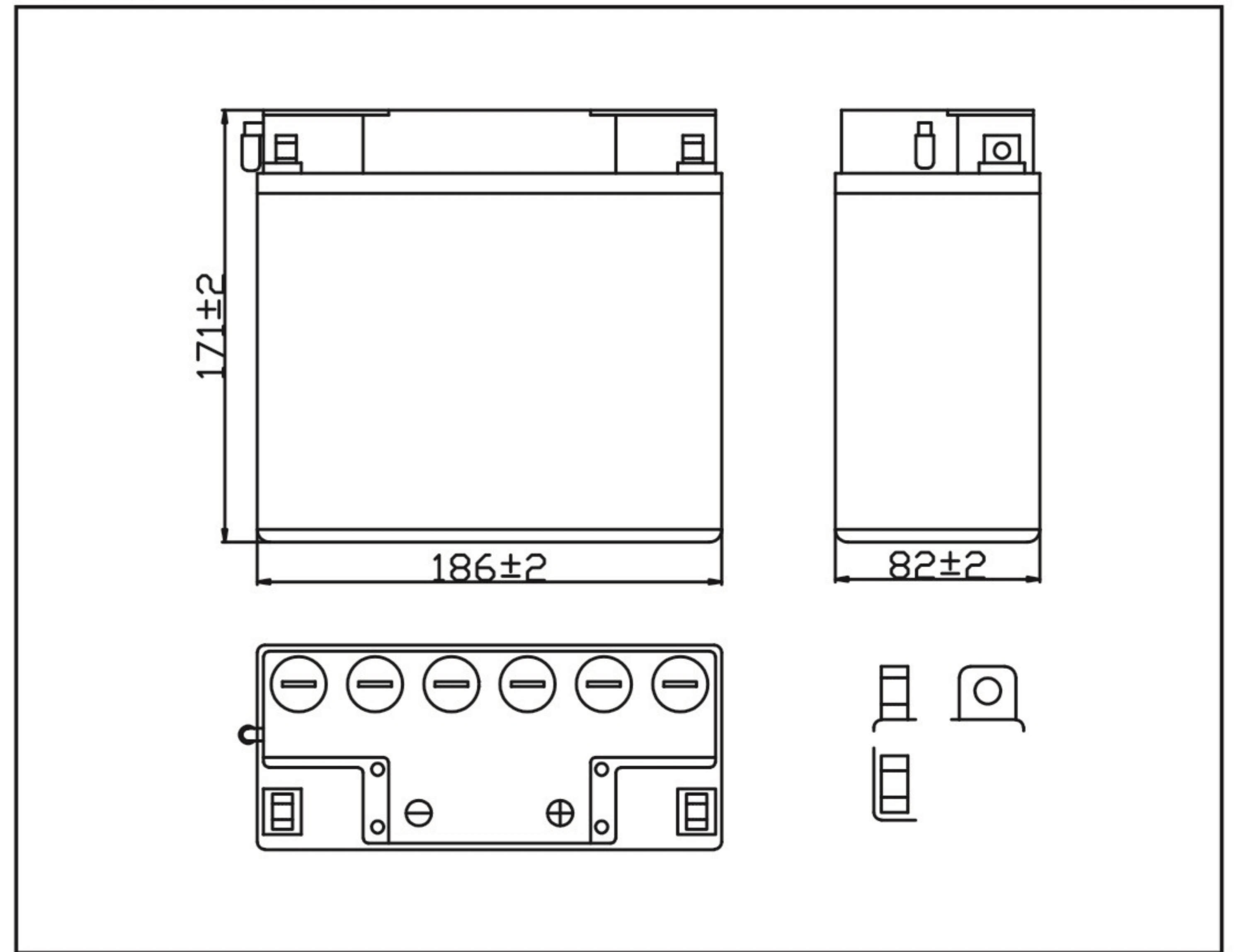

### Parts:

Executed Standard:JISD 5302-2004

Cover	Container Bottom	Terminal	Positive Plate	Negative Plate	Separator	Electrolyte	Safety Valve	Explosion Plate	Way of Sealing
PP	PP	Pb	PbO <sub>2</sub>	Pb	PE/Compound Fibre	dilute sulphuric acid	Rubber	PP	Heat Sealing

### Parameter Chart:

Volts	12V		
Capacity (25°C)	10 hours rate		19Ah
Appx.Dimension (mm)	L±2		186
	W±2		82
	H±2		171
Storage Status	Dry		
Weight (Approx)	4.25Kg	Weight w/ Acid	1.92Kg
Retention of Charge Storage @25°C			
1 month	97%	Directly Mounted	
3 month	90%	Directly Mounted	
6 month	80%	Constant Volts:14.4V Limit Current:3.8A Charging Hours:2-3H	
12 month	40%	Constant Volts:14.4V Limit Current:3.8A Charging Hours:4-6H	
CCA	Factory Standard (-10°C)	Factory Standard (-18°C)	
Discharging Current	130A	170A	

### Discharge Current 25°C

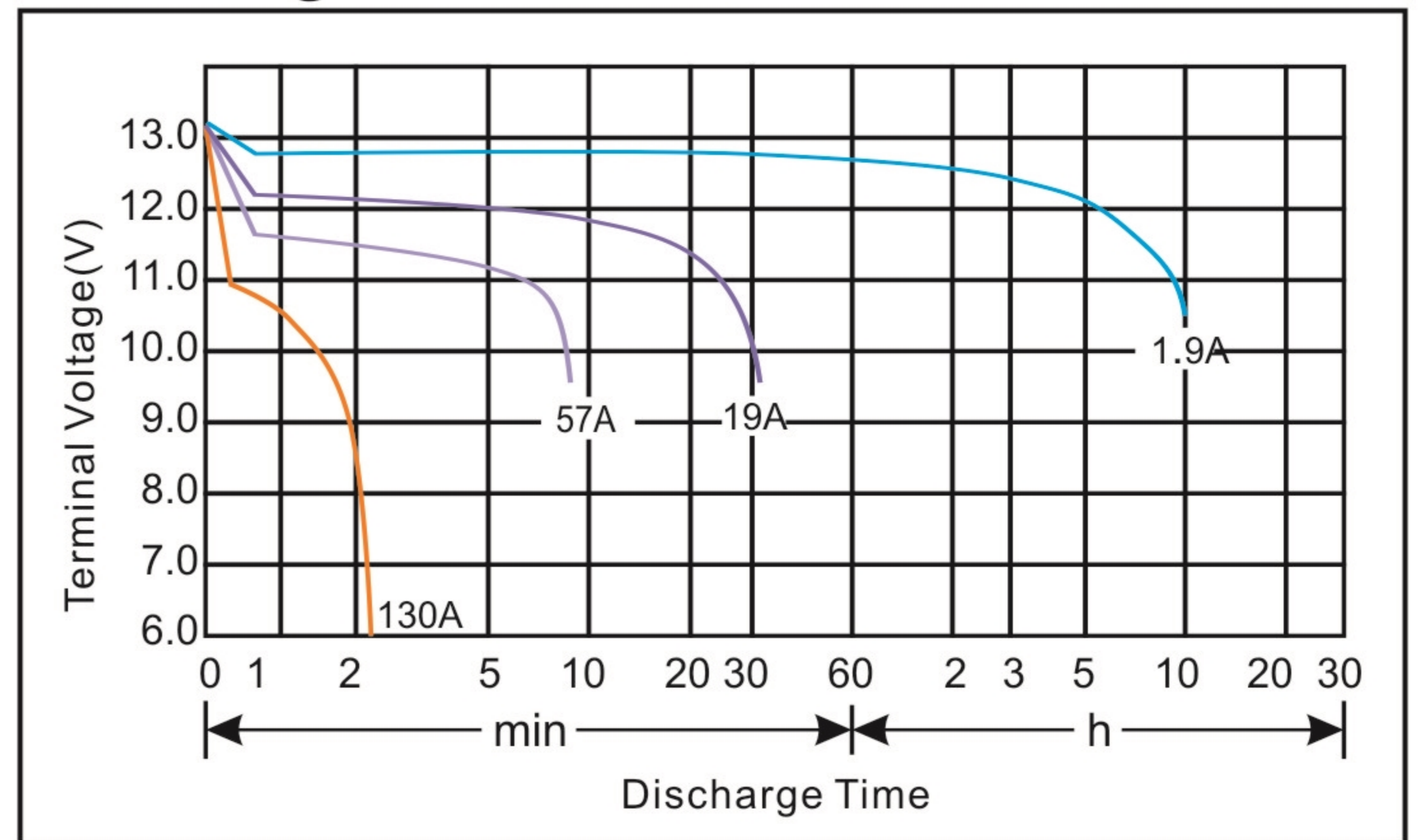

### Residual Capacity

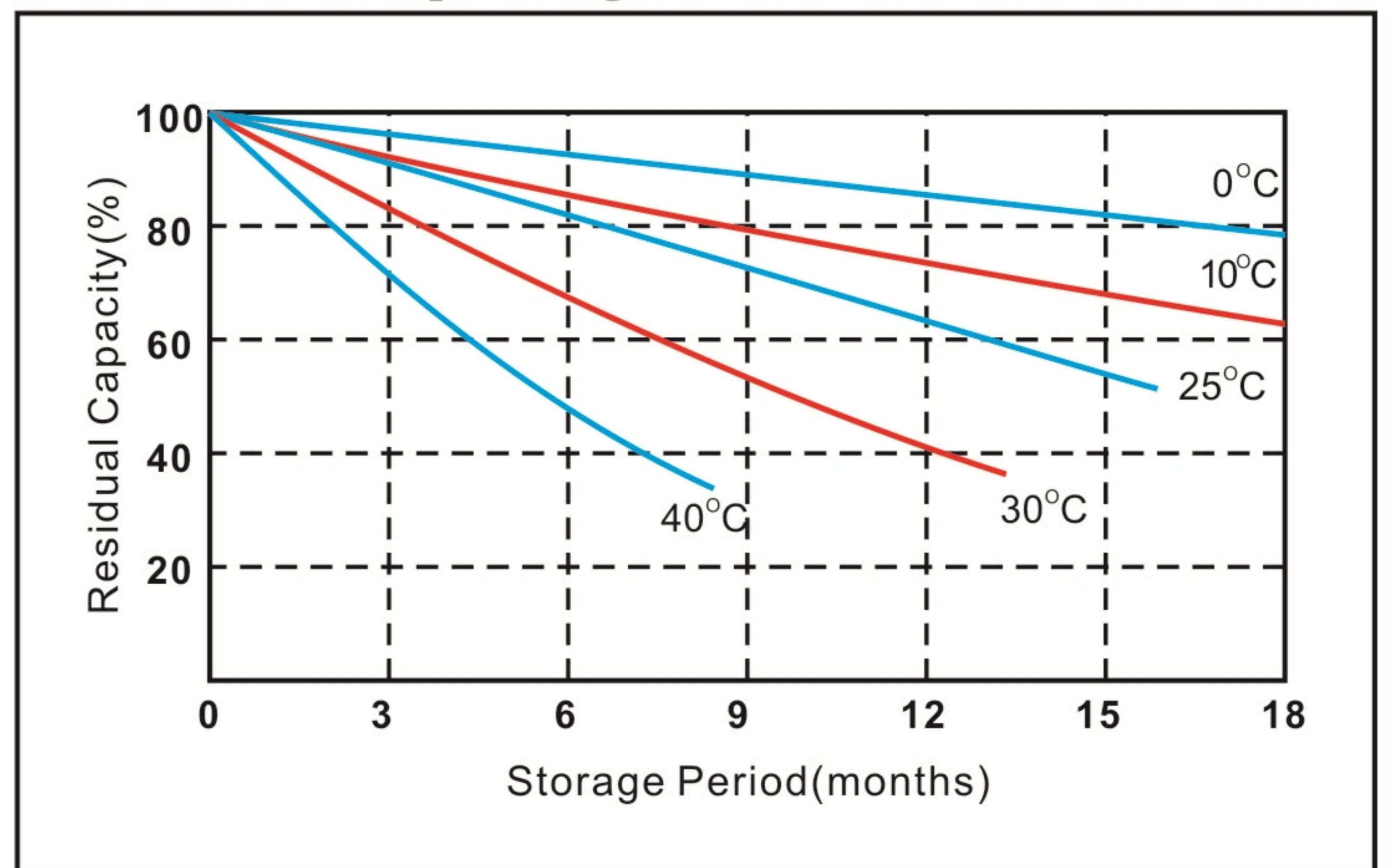

★The above are average and data obtained from the first 3 charge/discharge cycles. These are not minimum values.

★The different item No. of battery can be developed according to the customer's demand.