



MKP88
MKP88 series

MKP88 型塑料外壳干式直流滤波电容

MKP88 DC-Filter Capacitor (Box-Type, Dry-Type)

◆ 外形尺寸图 Outline Drawing



图 1: 引出类型一 Style1 L×F×N×S=26*16.8*15*



图 2: 引出类型二 Style2 L×F×N×S=26*16.8*15*6

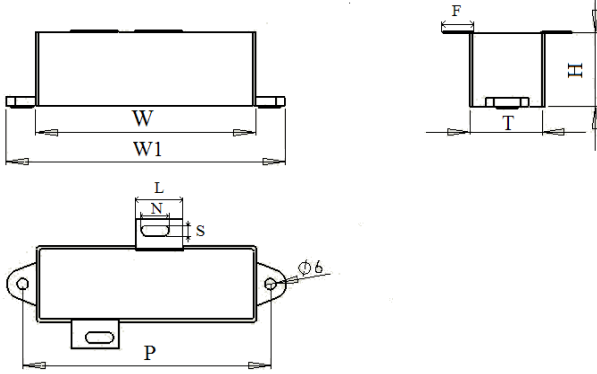

图 3: 引出类型三 Style3

◆ 特点及用途 Application and Feature

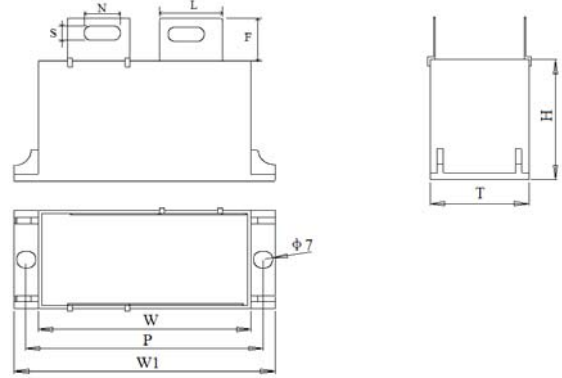
自感小，等效串联电阻小，高纹波电流承受能力，通常用于焊机、感应加热设备、逆变器的直流母线滤波电路当中。

Low inductance, Low ESR, Support high ripple current, especially used in DC-filter circuit for welding machine, inverter, induction heating equipment.

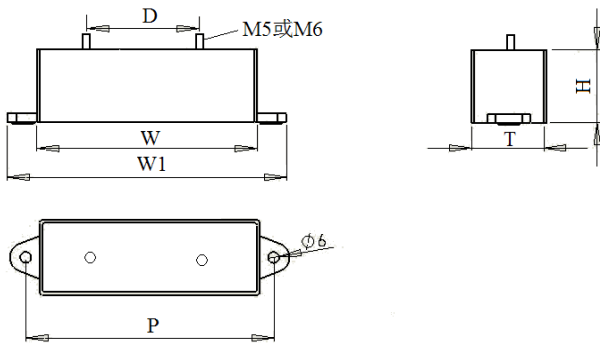
◆ 典型应用 Typical Applications

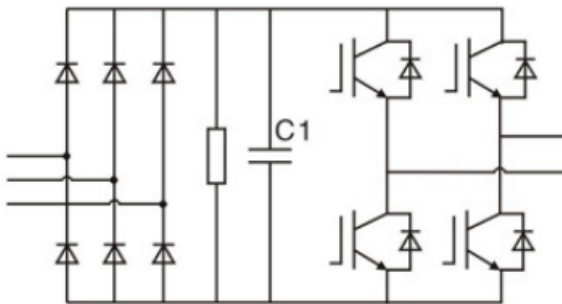

C1: MKP88 type DC- filter capacitor

◆ 技术要求 Specifications

参照标准 Reference Standard	IEC 61071
气候类别 Climatic Category	40/85/56
额定电压 Rated Voltage	800Vdc/500Vac、1100Vdc/700Vac
工作温度范围 Operation Temperature Range	-40℃~85℃(hotspot)
电容量 Capacitance Range	20μF~110μF (According to customer requirements)
电容量偏差 Capacitance Tolerance	±5%(J)、±10%(K) (20±5℃,1KHz)
耐电压 Voltage Proof	U=1.5U _R (20℃, 10s)
绝缘电阻 Insulation Resistance	IR×C≥10 000s (20℃, 100Vdc, 1min)
损耗角正切 Dissipation Factor	100Hz: Tan δ≤0.0004
工作寿命 Operation Life Time	100 000 hours at U _{NDC} , Θ _{max} =70℃

◆ 产品代码编写说明: Part number code system:

16 位产品代码如下: The 16 digits part number is formed as follow:

1 2 3 4 5 6 7 8 9 10 11 12 13 14 15 16

M	K	8	8												
---	---	---	---	--	--	--	--	--	--	--	--	--	--	--	--

第 1~4 位	薄膜电容器系列代码 MK88=MKP88	Digit 1~4	Series code of film capacitor MK88=MKP88
第 5~7 位	标称容量代码 举例: 104=10×104pF=0.1 μ F	Digit 5~7	Rated capacitance value code For example: 104=10×104pF=0.1 μ F
第 8 位	容量等级代码 J=±5% K=±10%	Digit 8	Capacitance tolerance code J=±5% K=±10%
第 9~10 位	直流额定电压代码 1W=800V 3K=1100V	Digit 9~10	DC rated voltage code 1W=800V 3K=1100V
第 11 位	外壳宽度 1=120mm 2=88mm 3=150mm	Digit 11	Wide of case 1=120mm 2=88mm 3=150mm
第 12 位	内部特征码	Digit 12	Internal use
第 13~16 位	引出端代码 0000 表示客户定制 其他见表 1	Digit 13~16	Terminals code 0000 = customized Referring to table 1
表 1	引出端代码	Table 1	Terminals code

第 13 位 Digit 13		第 14 位 Digit 14		第 15~16 位 Digit 15~16	
端子引出方式 Style for terminals		焊片高度(螺栓直径) Height for solder slice(mm)		焊片尺寸(螺栓距离) Size for solder slice(mm)	
代码 Code	说明 explanation	代码 Code	说明 explanation	代码 Code	说明 explanation
1	style 1 图 1	0	0	00	L×F×N×S=26×16.8×15×6
2	style 2 图 2				
3	style 3 图 3	5	M5	00	标准距离 Standard distance
		6	M6		



MKP88

MKP88 series

◆ 产品尺寸及性能参数: **Product Dimension and Characteristic Data:**

800Vdc/500Vac								
C (μ F)	W \pm 2.0	H \pm 2.0	T \pm 2.0	W1 \pm 2.0	P \pm 2.0	D \pm 2.0	ESR max@10kHz (m Ω)	产品代码 Part number
20.0	88.0	40.0	40.0	108.0	98.0	40.0	7.0	MK88206-1W20****
30.0	88.0	40.0	40.0	108.0	98.0	40.0	7.0	MK88306-1W20****
40.0	88.0	50.0	40.0	108.0	98.0	40.0	6.0	MK88406-1W20****
50.0	120.0	40.0	41.0	152.0	135.0	70.0	6.0	MK88506-1W10****
60.0	120.0	45.0	41.0	152.0	135.0	70.0	6.0	MK88606-1W10****
70.0	120.0	45.0	45.0	152.0	135.0	70.0	6.0	MK88706-1W10****
80.0	150.0	45.0	45.0	182.0	165.0	100.0	6.0	MK88806-1W30****
90.0	150.0	50.0	45.0	182.0	165.0	100.0	6.0	MK88906-1W30****
100.0	150.0	50.0	45.0	182.0	165.0	100.0	5.0	MK88107-1W30****
110.0	150.0	50.0	50.0	182.0	165.0	100.0	5.0	MK88117-1W30****

1100Vdc/650Vac								
C (μ F)	W \pm 2.0	H \pm 2.0	T \pm 2.0	W1 \pm 2.0	P \pm 2.0	D \pm 2.0	ESR max@10kHz (m Ω)	产品代码 Part number
20.0	88.0	40.0	40.0	108.0	98.0	40.0	7.0	MK88206-3K20****
30.0	88.0	50.0	40.0	108.0	98.0	40.0	7.0	MK88306-3K20****
40.0	120.0	45.0	41.0	152.0	135.0	70.0	6.0	MK88406-3K10****
50.0	120.0	50.0	45.0	152.0	135.0	70.0	6.0	MK88506-3K10****
60.0	150.0	50.0	45.0	182.0	165.0	100.0	6.0	MK88606-3K30****
70.0	150.0	50.0	50.0	182.0	165.0	100.0	6.0	MK88706-3K30****
80.0	150.0	55.0	50.0	182.0	165.0	100.0	5.0	MK88806-3K30****

备注:

“-” : 客户要求的容量偏差

“****” : 引出端代码, 见表 1

“-”=custom's capacitor tolerance code, J= \pm 5%, K= \pm 10%, M= \pm 20%

“****”=Terminals code, referring to table 1

◆可靠性: Reliability

Test description	Reference	Test conditions	Determine criteria
极间耐压 Voltage test between terminals	IEC 61071	1.5 x U _{NDC} at Tamb Duration: 60 s	No visible damage ΔC/C : ≤0.5% tan δ: ≤1.2 initial tan δ+ 1×10 ⁻⁴ at 10KHz R _{ins} : ≥ 50% of IR limit
放电实验 Surge discharge test	IEC 61071	1.1 x U _{NDC} Number of discharges: 5(within 10 minutes)	No visible damage ΔC/C : ≤1.0% tan δ: ≤1.2 initial tan δ+ 1×10 ⁻⁴ at 10KHz R _{ins} : ≥ 50% of IR limit
温度变化 Change of temperature	IEC 60068-2-14	Tmax. = 85 °C Tmin. = - 40 °C Transition time: 1 h, equivalent to 1°C/min 5 cycles	No visible damage ΔC/C : ≤ 2.0 % Increase of tan δ: ≤ 150 ×10 ⁻⁴ at 10KHz R _{ins} : ≥ 50% of IR limit
耐湿性 Damp heat steady	IEC 60068-2-78	Tmax. = 40 °C RH = 93 % Duration 56 days	No visible damage ΔC/C : ≤ 2.0 % Increase of tan δ: ≤ 150 ×10 ⁻⁴ at 10KHz R _{ins} : ≥ 50% of IR limit
耐久性 Endurance test between terminals	IEC 61071	1.3 × U _{NDC} at Tmax. = 85 °C Duration 500 h 1000 × discharge at 1.4 × I (repetitive peak current in continuous operation) 1.3× U _{NDC} at Tmax. = 85 °C Duration 500 h	No visible damage ΔC/C : ≤ 3.0 % Increase of tan δ: ≤ 150 ×10 ⁻⁴ at 10KHz R _{ins} : ≥ 50% of IR limit
自愈性测试 Self healing test	IEC 61071	1.5 × U _{NDC} Duration 10 sec , Number of Self healing ≤ 5 , increase the voltage at 100 V/s till 5 , with a max. of 2.5 × U _{NDC} for a duration of 10 sec	No visible damage ΔC/C : ≤0.5% tan δ: ≤1.1 initial tan δ+ 1×10 ⁻⁴ at 10KHz
振动 Vibration	IEC60068	f=10 Hz to 55 Hz, a=±0.35mm Test duration per axis = 10 frequency cycles (3 axes offset from each other by 90°)1 octave/min, the total times are 135 min for 3axes	No visible damage