

### Description

The SLVU2.8-4 is designed to protect low voltage, CMOS semiconductors from transients caused by electrostatic discharge (ESD), cable discharge events (CDE), lightning and other induced voltage surges. Low capacitance compensation diode is integrated into the TVS to lower the typical capacitance to 1pf per line. The SLVU2.8-4 complies with the IEC 61000-4-2 (ESD) standard with  $\pm 15kV$  air and  $\pm 8kV$  contact discharge. The SLVU2.8-4 is assembled into a 8-pin lead-free SO-8 package, The combination of low leakage, signal integrity and flow through design makes the SLVU2.8-4 an ideal application such as 10/100/1000 Ethernet.

### Features

- 600W peak pulse power (8/20 $\mu$ s)
- Protects two line pairs (four lines)
- Ultra low leakage: nA level
- Low operating voltage: 2.8V
- Very low capacitance: 2pF
- Ultra low clamping voltage
- JEDEC SO-8 package
- Complies with following standards:
  - IEC 61000-4-2 (ESD) immunity test  
Air discharge:  $\pm 30kV$   
Contact discharge:  $\pm 30kV$
  - IEC61000-4-5 (Lightning) 30A (8/20 $\mu$ s)
- RoHS Compliant

### Mechanical Characteristics

- Package: SO-8
- Lead Finish: Matte Tin
- Terminal Connections: See Diagram Below
- Marking Information: See Below

### Applications

- Base Station
- Analog Inputs
- Switch Systems
- 10/100/1000 Ethernet
- WAN/LAN Equipment
- Desktops, Servers, and Notebooks
- Low Voltage Interfaces

### Marking Information

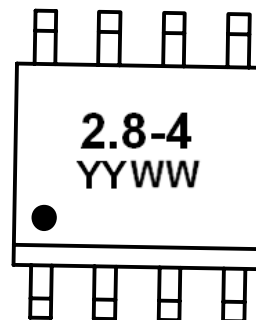

2.8-4= Device Marking Code  
 YYWW = Date Code  
 Dot denotes Pin1

### Dimensions and Pin Configuration

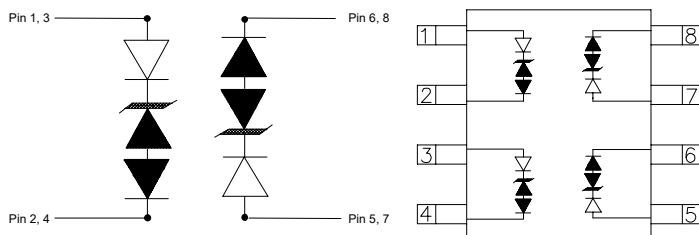

Circuit and Pin Schematic

SO-8 Outline

### Ordering Information

Part Number	Packaging	Reel Size
SLVU2.8-4	2500/Tape & Reel	13 inch

**Absolute Maximum Ratings (T<sub>A</sub>=25°C unless otherwise specified)**

Parameter	Symbol	Value	Unit
Peak Pulse Power (8/20μs)	P <sub>pk</sub>	600	W
Peak Pulse Current (8/20μs)	I <sub>PP</sub>	30	A
ESD per IEC 61000-4-2 (Air)	V <sub>ESD</sub>	±30	kV
ESD per IEC 61000-4-2 (Contact)		±30	
Operating Temperature Range	T <sub>J</sub>	-55 to +125	°C
Storage Temperature Range	T <sub>stg</sub>	-55 to +150	°C

**Electrical Characteristics (T<sub>A</sub>=25°C unless otherwise specified)**

Parameter	Symbol	Min	Typ	Max	Unit	Test Condition
Reverse Working Voltage	V <sub>RWM</sub>			2.8	V	
Breakdown Voltage	V <sub>BR</sub>	3.0			V	I <sub>T</sub> = 2μA
	V <sub>SB</sub>	3.0			V	I <sub>SB</sub> = 50mA
Reverse Leakage Current	I <sub>R</sub>		0.001	1	μA	V <sub>RWM</sub> = 2.8V
Clamping Voltage	V <sub>C</sub>			8.5	V	I <sub>PP</sub> = 5A (8 x 20μs pulse)
Clamping Voltage	V <sub>C</sub>			18	V	I <sub>PP</sub> = 25A (8 x 20μs pulse)
Clamping Voltage	V <sub>C</sub>			20	V	I <sub>PP</sub> = 30A (8 x 20μs pulse)
Junction Capacitance	C <sub>J</sub>		2	3	pF	V <sub>R</sub> = 0V, f = 1MHz

**Typical Performance Characteristics ( $T_A=25^\circ\text{C}$  unless otherwise Specified)**

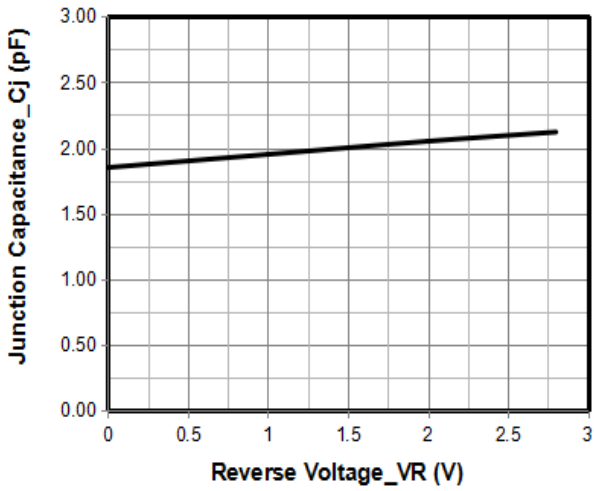

Junction Capacitance vs. Reverse Voltage

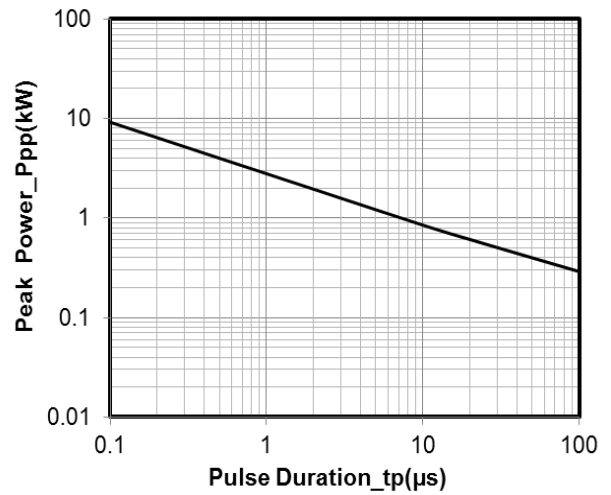

Peak Pulse Power vs. Pulse Time

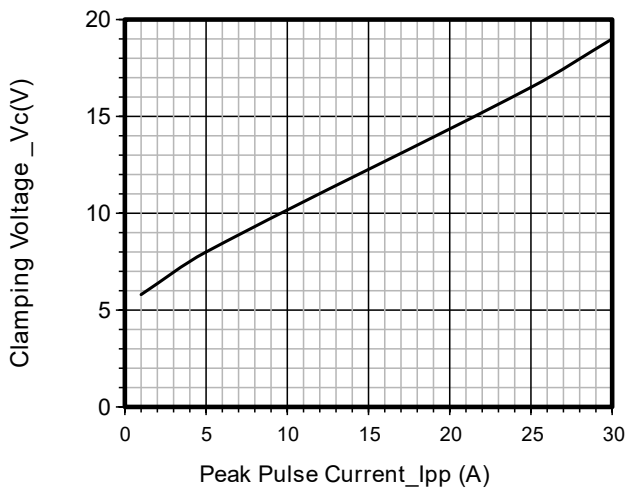

Clamping Voltage vs. Peak Pulse Current

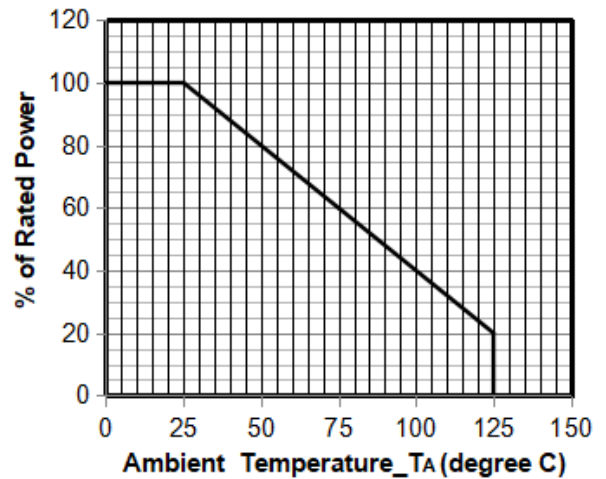

Power Derating Curve

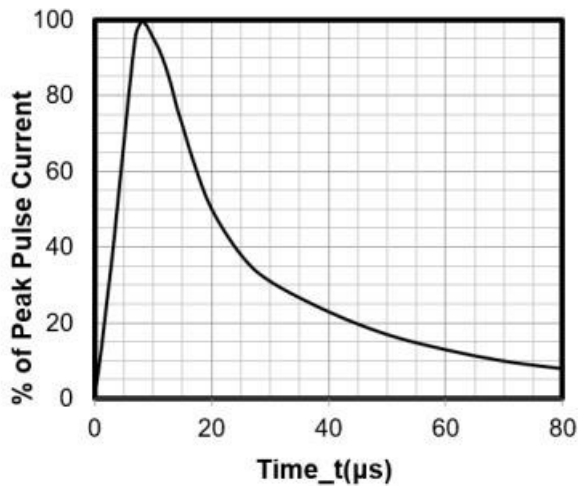

8 X 20μs Pulse Waveform

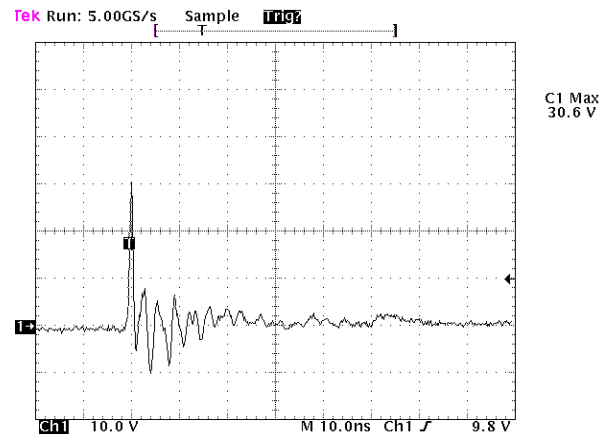

Note: Data is taken with a 10x attenuator

**ESD Clamping Voltage**  
**8 kV Contact per IEC61000-4-2**

### Typical Application

The SLVU2.8-4 is designed such that the data lines are routed through the device. The first line pair enters at pins 1 and 2 and exit at pins 8 and 7 respectively. The second line pair enters at pins 3 and 4 and exits at pins 6 and 5. The traces must be connected at the bottom of the device as shown.

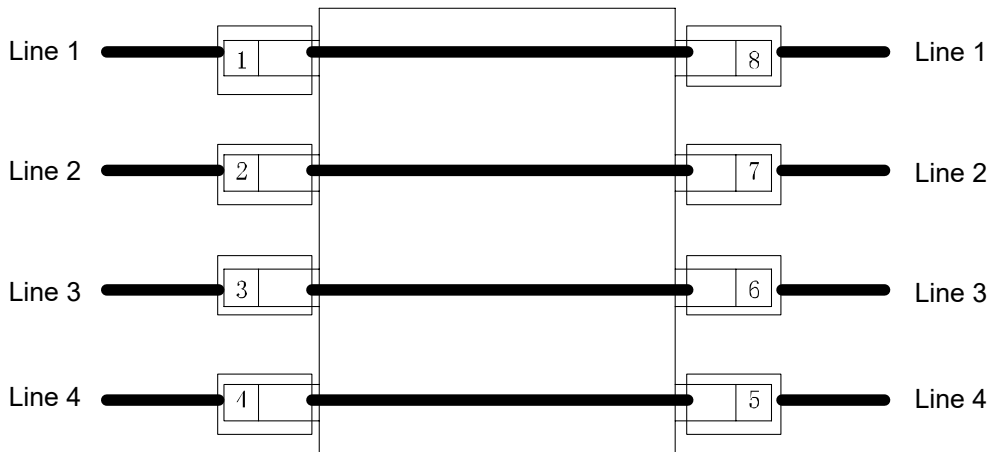

Low capacitance protection of two differential line pairs

### SLVU2.8-4 on Ethernet Application

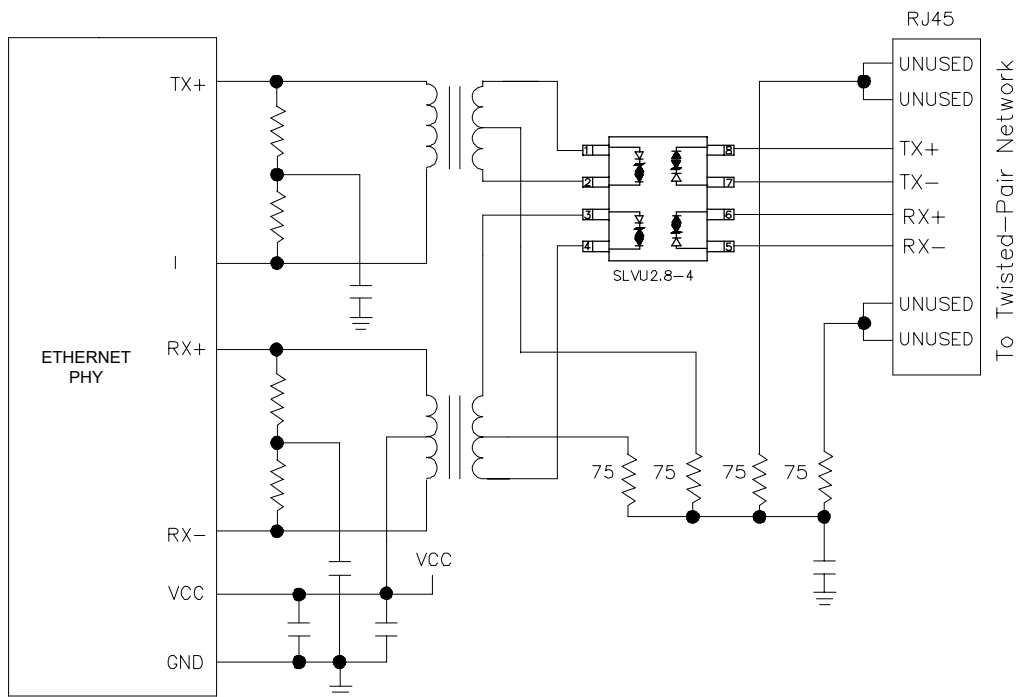

### SO-8 Package Outline Drawing

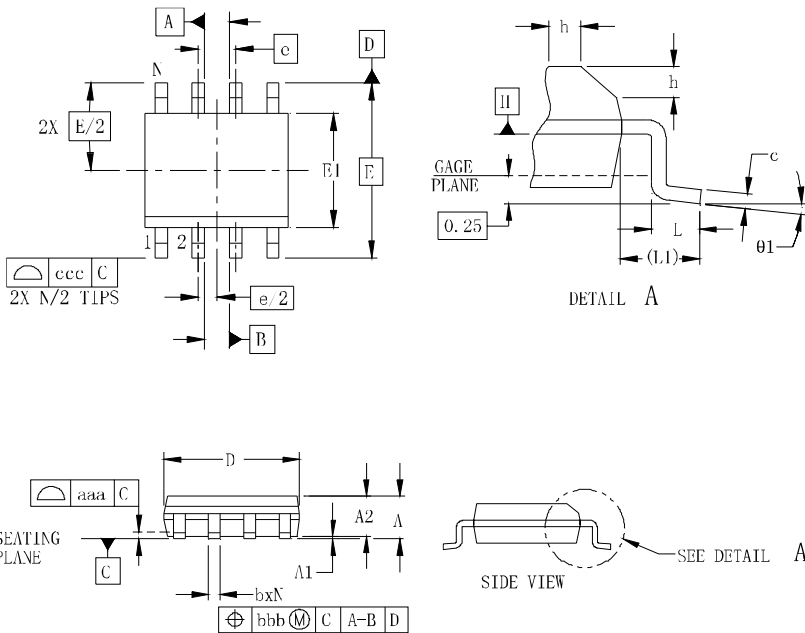

SYM	DIMENSIONS					
	MILLIMETERS			INCHES		
	MIN	NOM	MAX	MIN	NOM	MAX
A	1.35		1.75	0.053		0.069
A1	0.10		0.25	0.004		0.010
A2	1.25		1.65	0.049		0.065
b	0.31		0.51	0.012		0.020
c	0.17		0.25	0.007		0.010
D	4.80	4.90	5.00	0.189	0.193	0.197
E1	3.80	3.90	4.00	0.150	0.154	0.157
E	6.00 BSC			0.236 BSC		
e	1.27 BSC			0.050 BSC		
h	0.25		0.50	0.010		0.020
L	0.40	0.72	1.04	0.016	0.028	0.041
L1	(1.04)			(0.041)		
N	8			8		
θ1	0°		8°	0°		8°
aaa	0.10			0.004		
bbb	0.25			0.010		
ccc	0.20			0.008		

### Suggested Land Pattern

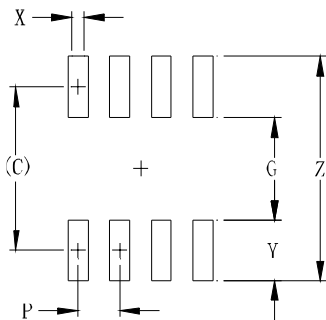

SYM	DIMENSIONS	
	MILLIMETERS	INCHES
C	(5.20)	0.205
G	3.00	0.118
P	1.27	0.050
X	0.60	0.024
Y	2.20	0.087
Z	7.40	0.291

### Contact Information

Applied Power Microelectronics Inc.  
 Website: <http://www.appliedpowermicro.com>  
 Email: [sales@appliedpowermicro.com](mailto:sales@appliedpowermicro.com)  
 Phone: +86 (0519) 8399 3606

Applied Power Microelectronics Inc. (APM) reserves the right to make changes to the product specification and data in this document without notice. APM makes no warranty, representation or guarantee regarding the suitability of its products for any particular purpose, nor does APM assume any liability arising from the application or use of any products or circuits, and specifically disclaims any and all liability, including without limitation special, consequential or incidental damages.