

Description

The CMP3007F5 is the P-Channel enhancement mode power field effect transistors with high cell density, trench technology. This high density process and design have been optimized switching performance and especially tailored to minimize on-state resistance.

Features

- V_{DS} : -30V
- I_D : -58A
- $R_{DS(on)}$ (@ $V_{GS}=-10V$): < 8m Ω
- $R_{DS(on)}$ (@ $V_{GS}=-4.5V$): < 12m Ω
- High density cell design for extremely low $R_{DS(on)}$
- Excellent on-resistance and DC current capability

Equivalent Circuit and Pin Configuration

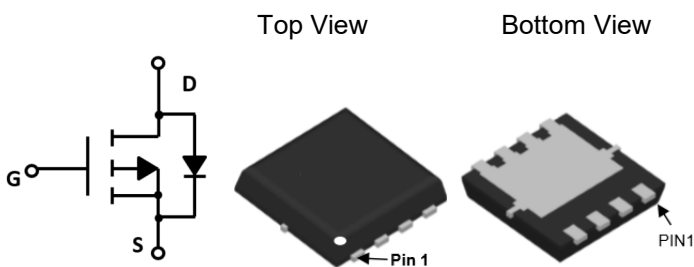

Applications

- Battery management
- Power management
- Load switch

Marking Information

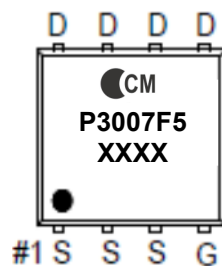

Marking Code = CMP3007F5

Date Code = XXXX

Ordering Information

Part Number	Packaging	Reel Size
CMP3007F5	5000/Tape & Reel	13 inch

Absolute Maximum Ratings (TA=25 °C unless otherwise noted)

Parameter	Symbol	Maximum	Unit	
Drain-source Voltage	V_{DS}	-30	V	
Gate-source Voltage	V_{GS}	± 20	V	
Drain Current ⁽¹⁾⁽⁶⁾	I_D	TC=25°C	-58	A
		TC=100°C	-37	A
	I_D	TA=25°C	-15	A
		TA=100°C	-10	A
Pulsed Drain Current ⁽³⁾	I_{DM}	-232	A	
Total Power Dissipation ⁽⁴⁾	PD	TC=25°C	60	W
		TA=25°C	4.1	W
Thermal Resistance Junction-to-Ambient ⁽²⁾⁽⁵⁾	$R_{\theta JA}$	30	°C/W	
Thermal Resistance Junction-to-Case	$R_{\theta JC}$	2.1	°C/W	
Junction and Storage Temperature Range	T_J, T_{STG}	-55 to +150	°C	

Electrical Characteristics (T_J=25 °C unless otherwise noted)

Parameter	Symbol	Conditions	Min	Typ	Max	Units
Static Parameter						
Drain-Source Breakdown Voltage	BV _{DSS}	V _{GS} =0V, I _D =-250μA	-30			V
Zero Gate Voltage Drain Current	I _{DSS}	V _{DS} =-30V, V _{GS} =0V, T _C =25°C			-1	μA
Gate-Body Leakage Current	I _{GSS}	V _{GS} = ± 20V, V _{DS} =0V			±100	nA
Gate Threshold Voltage	V _{GS(th)}	V _{DS} =V _{GS} , I _D =-250μA	-1.1		-2.5	V
Static Drain-Source on-Resistance	R _{DS(on)}	V _{GS} =-10V, I _D =-10A		6.5	8	mΩ
		V _{GS} =-4.5V, I _D =-10A		8.5	12	
Diode Forward Voltage	V _{SD}	I _S =-1A, V _{GS} =0V			-1.0	V
Maximum Body-Diode Continuous Current	I _S				-58	A
Dynamic Parameters						
Input Capacitance	C _{iss}	V _{DS} =-15V, V _{GS} =0V, f=1MHz		5500		pF
Output Capacitance	C _{oss}			740		
Reverse Transfer Capacitance	C _{rss}			650		
Switching Parameters						
Total Gate Charge	Q _g	V _{GS} =-10V, V _{DS} =-15V, I _D =-20A		132		nC
Gate Source Charge	Q _{gs}			12		
Gate Drain Charge	Q _{gd}			20		
Turn-on Delay Time	t _{D(on)}	V _{GS} =-10V, V _{DS} =-15V, R _L =0.75Ω, R _{GEN} =3Ω		44		ns
Turn-on Rise Time	t _r			38		
Turn-off Delay Time	t _{D(off)}			272		
Turn-off Fall Time	t _f			110		

Noted: (1) Pulse Test: Pulse Width ≤ 300us, Duty cycle ≤ 2%.

(2) The value of R_{θJA} is measured with the device mounted on lin2 FR-4 board with 2oz. Copper, in a still air environment with T_A = 25°C. The Power dissipation P_{DSM} is based on R_{θJA} t ≤ 10s and the maximum allowed junction temperature of 150°C. The value in any given application depends on the user's specific board design.

(3) Single pulse width limited by junction temperature T_{J(MAX)} = 150°C.

(4) The power dissipation PD is based on T_{J(MAX)} = 150°C, using junction-to-case thermal resistance, and is more useful in setting the upper Dissipation limit for cases where additional heatsinking is used.

(5) The R_{θJA} is the sum of the thermal impedance from junction to case R_{θJA} and case to ambient.

(6) Drain current limited by maximum junction temperature.

Typical Performance Characteristics

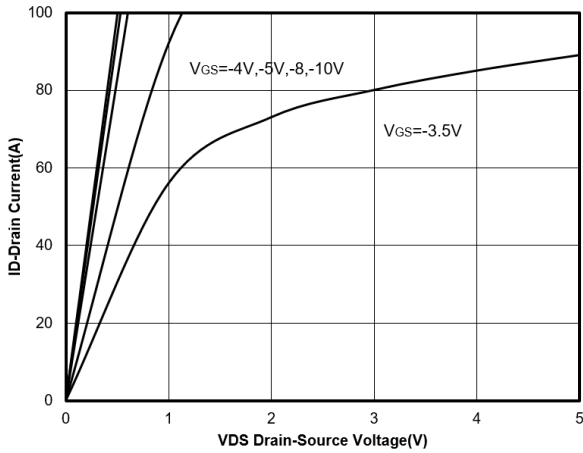

Figure 1. Output Characteristics

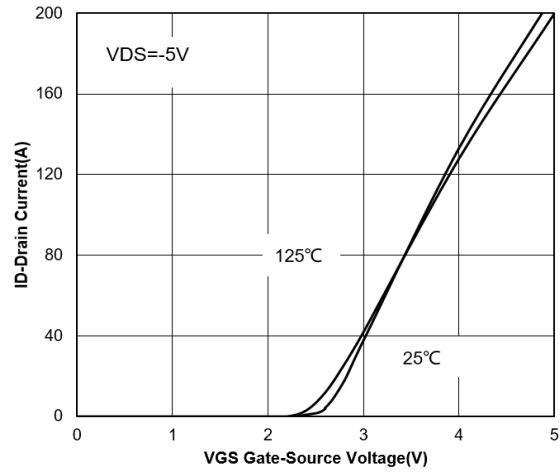

Figure 2. Transfer Characteristics

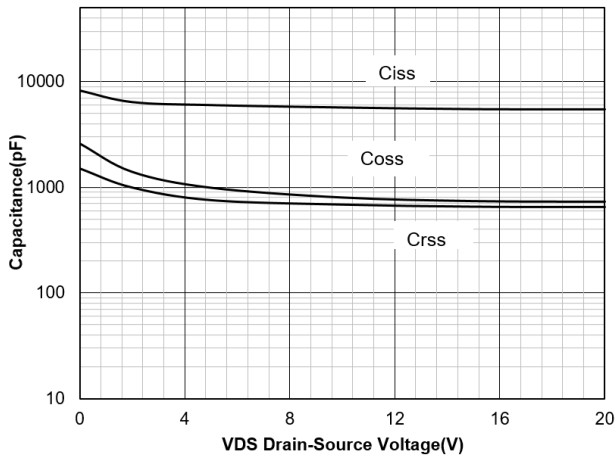

Figure 3. Capacitance Characteristics

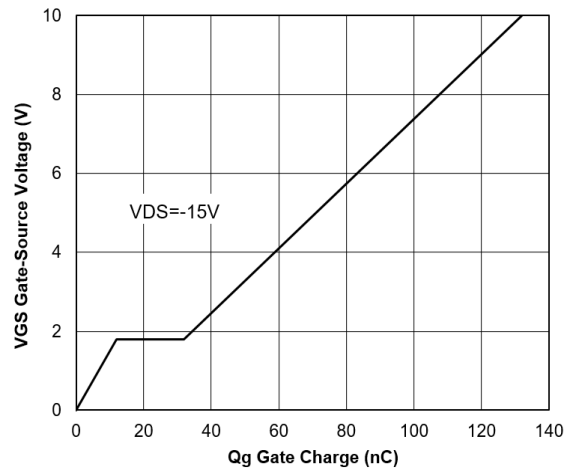

Figure 4. Gate Charge

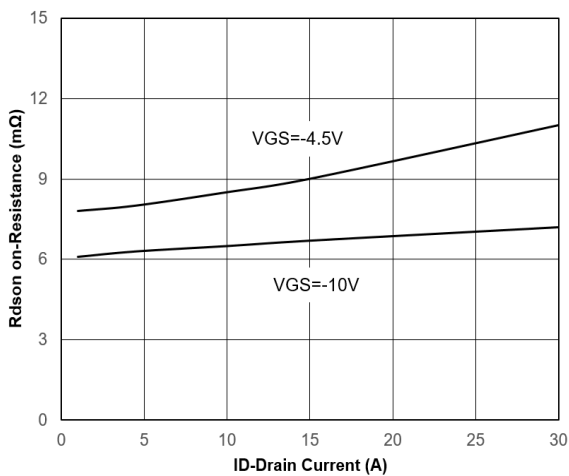

Figure 5. Drain-Source on Resistance

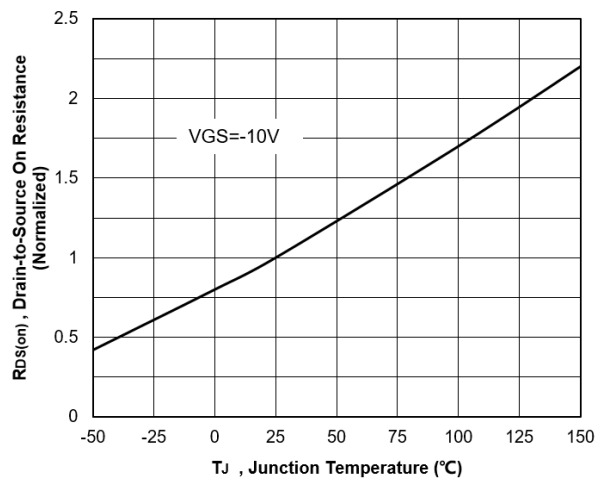

Figure 6. Normalized On-Resistance Vs. Temperature

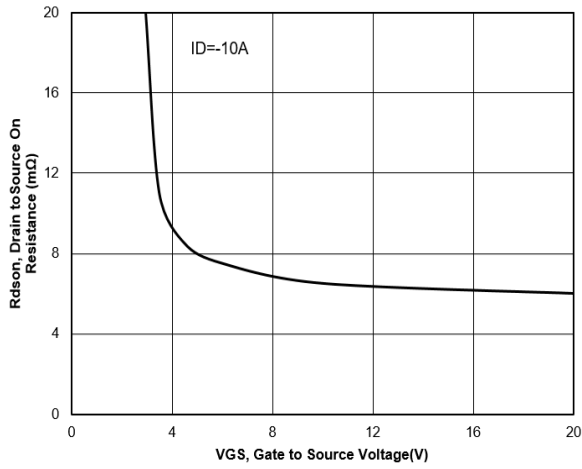

Figure 7. Typical Drain to Source ON Resistance VS Gate Voltage and Drain Current

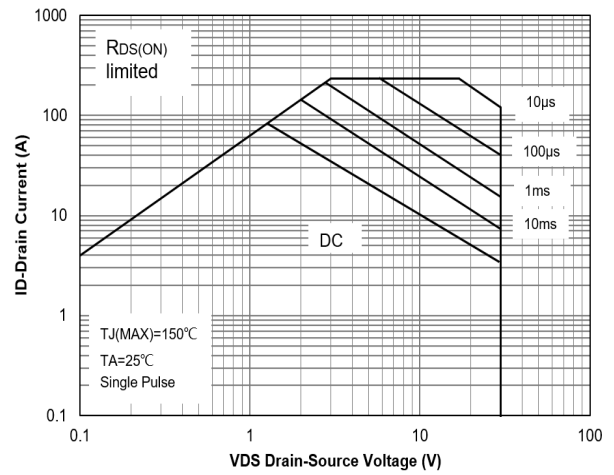

Figure 8. Safe Operation Area

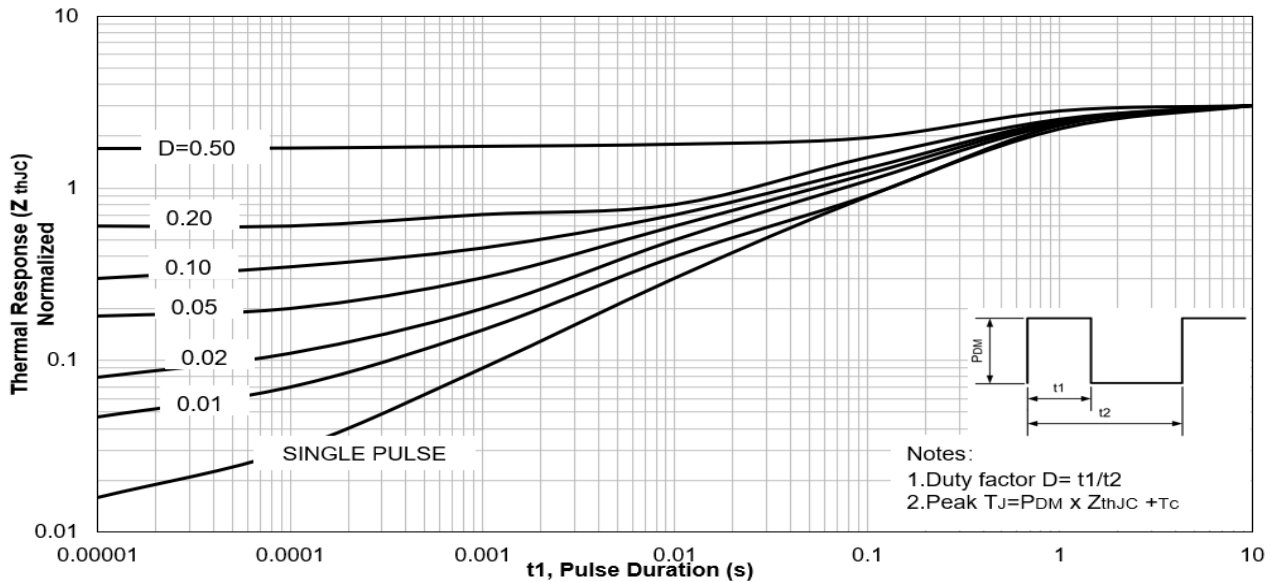

Figure 9. Maximum Effective Transient Thermal Impedance, Junction-to-Case

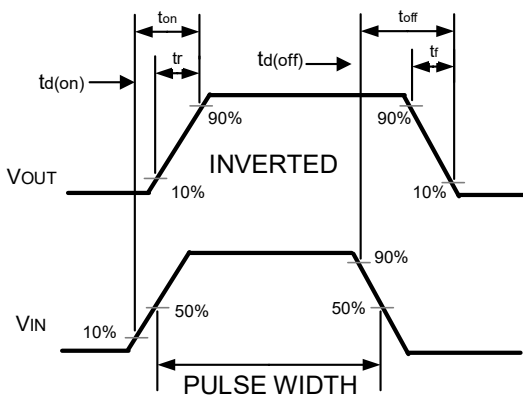
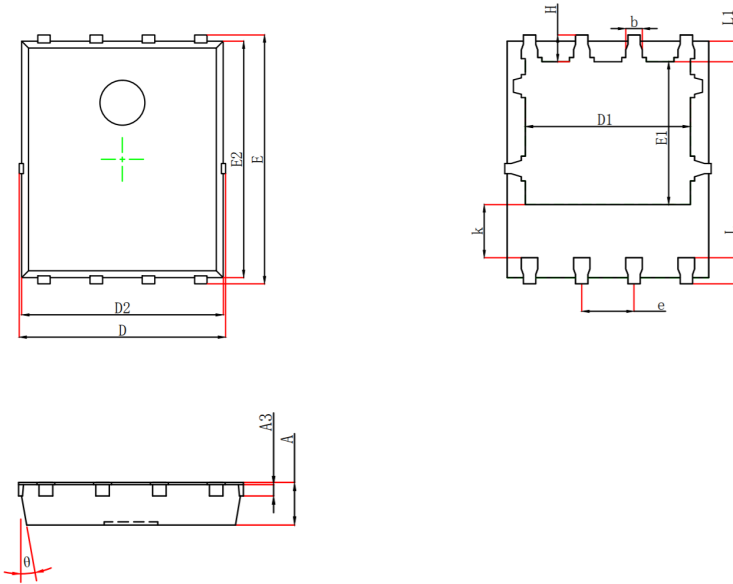

Figure 10. Switching wave

DFN 5X6 Package Outline Drawing



Symbol	Millimeters		Inches	
	Min.	Max.	Min.	Max.
A	0.900	1.000	0.035	0.039
A3	0.254 REF.		0.010 REF.	
D	4.944	5.096	0.195	0.201
E	5.974	6.126	0.235	0.241
D1	3.910	4.110	0.154	0.162
E1	3.375	3.575	0.133	0.141
D2	4.824	4.976	0.190	0.196
E2	5.674	5.826	0.223	0.229
k	1.190	1.390	0.047	0.055
b	0.350	0.450	0.014	0.018
e	1.270 TYP.		0.050 TYP.	
L	0.559	0.711	0.022	0.028
L1	0.424	0.576	0.017	0.023
H	0.574	0.726	0.023	0.029
θ	10°	12°	10°	12°

Contact Information

Applied Power Microelectronics Inc.

Website: <http://www.appliedpowermicro.com>

Email: sales@appliedpowermicro.com

Phone: +86 (0519) 8399 3606