

Description

CMN4015S9 is the N-Channel enhancement mode power field effect transistors with high cell density, trench technology. This high density process and design have been optimized switching performance and especially tailored to minimize on-state resistance.

Features

- V_{DS} : 40V
- I_D : 9A
- $R_{DS(on)}$ (@ $V_{GS}=10V$) : < 17m Ω
- $R_{DS(on)}$ (@ $V_{GS}=4.5V$) : < 23m Ω
- High density cell design for extremely low $R_{DS(on)}$
- Excellent on-resistance and DC current capability

Equivalent Circuit and Pin Configuration

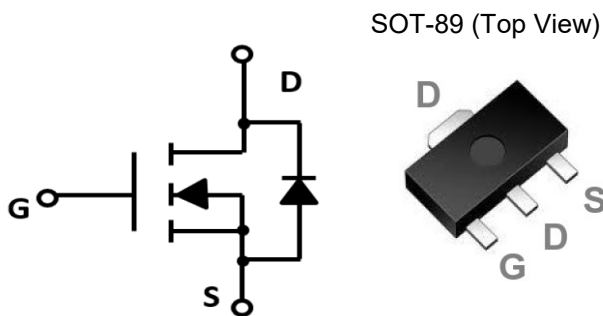

Applications

- Cellular Handsets and Accessories
- Personal Digital Assistants
- Portable Instrumentation
- Load switch

Marking Information

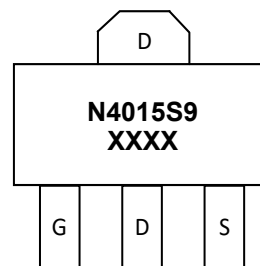

Device Code = N4015S9
 Date Code = XXXX

Ordering Information

Part Number	Packaging	Reel Size
CMN4015S9	1000/Tape & Reel	7 inch

Absolute Maximum Ratings (TA=25 °C unless otherwise noted)

Parameter	Symbol	Maximum	Unit	
Drain-source Voltage	V_{DS}	40	V	
Gate-source Voltage	V_{GS}	± 20	V	
Continuous Drain Current	I_D	$T_A=25^\circ C$	9	A
		$T_A=70^\circ C$	7	A
Pulsed Drain Current ⁽¹⁾	I_{DM}	36	A	
Total Power Dissipation @ $T_A=25^\circ C$ ⁽²⁾	P_D	1.8	W	
Thermal Resistance Junction-to-Ambient ⁽²⁾	$R_{\theta JA}$	70	$^\circ C/W$	
Junction and Storage Temperature Range	T_J, T_{STG}	-55 to +150	$^\circ C$	

Electrical Characteristics (T_J=25 °C unless otherwise noted)

Parameter	Symbol	Conditions	Min	Typ	Max	Units
Static Parameter						
Drain-Source Breakdown Voltage	BV _{DSS}	V _{GS} =0V, I _D =250μA	40			V
Zero Gate Voltage Drain Current	I _{DSS}	V _{DS} =40V, V _{GS} =0V, T _C =25°C			1	μA
Gate-Body Leakage Current	I _{GSS}	V _{GS} =±20V, V _{DS} =0V			±100	nA
Gate Threshold Voltage	V _{GS(th)}	V _{DS} =V _{GS} , I _D =250μA	1.0		2.5	V
Static Drain-Source on-Resistance	R _{DS(on)}	V _{GS} =10V, I _D =10A		14	17	mΩ
		V _{GS} =4.5V, I _D =10A		15	23	
Diode Forward Voltage	V _{SD}	I _S =9A, V _{GS} =0V			1.2	V
Maximum Body-Diode Continuous Current	I _S				9	A
Dynamic Parameters						
Input Capacitance	C _{iss}	V _{DS} =20V, V _{GS} =0V, f=1MHz		917		pF
Output Capacitance	C _{oss}			128		
Reverse Transfer Capacitance	C _{rss}			108		
Switching Parameters						
Total Gate Charge	Q _g	V _{GS} =10V, V _{DS} =20V, I _D =9A		24		nC
Gate Source Charge	Q _{gs}			4.5		
Gate Drain Charge	Q _{gd}			6.2		
Turn-on Delay Time	t _{D(on)}	V _{GS} =10V, V _{DS} =20V, I _D =2A, R _{GEN} =3Ω		10		ns
Turn-on Rise Time	t _r			56		
Turn-off Delay Time	t _{D(off)}			27		
Turn-off Fall Time	t _f			72		

Noted: (1) Pulse Test: Pulse Width ≤ 300μs, Duty cycle ≤ 2%.

(2) Device mounted on FR-4 PCB, 1 inch x 0.85 inch x 0.062 inch. With 2oz Copper, t ≤ 10s

Typical Performance Characteristics

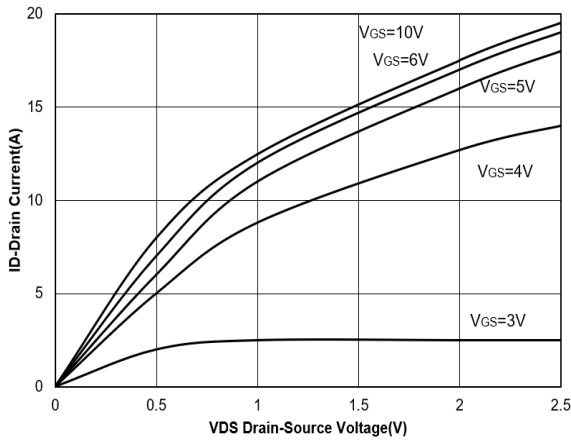

Figure 1. Output Characteristics

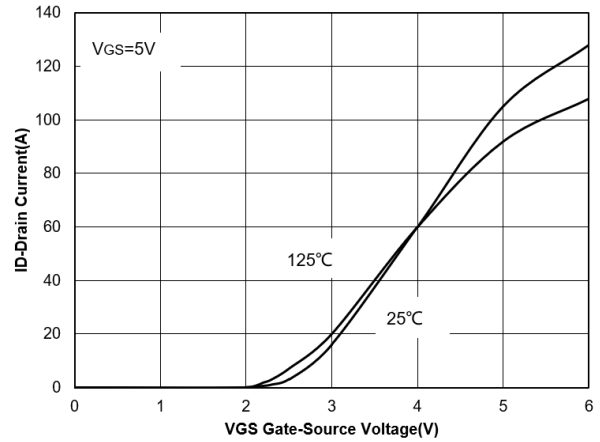

Figure 2. Transfer Characteristics

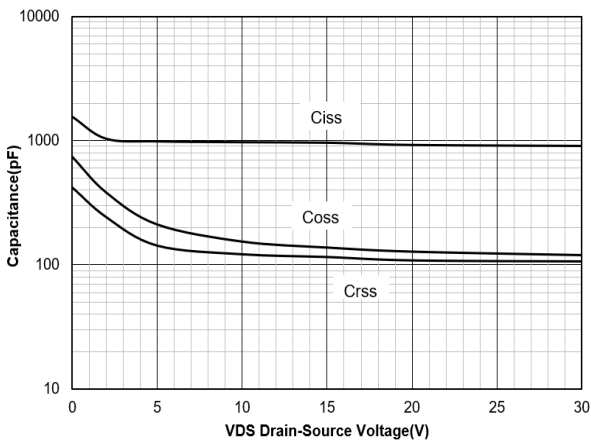

Figure 3. Capacitance Characteristics

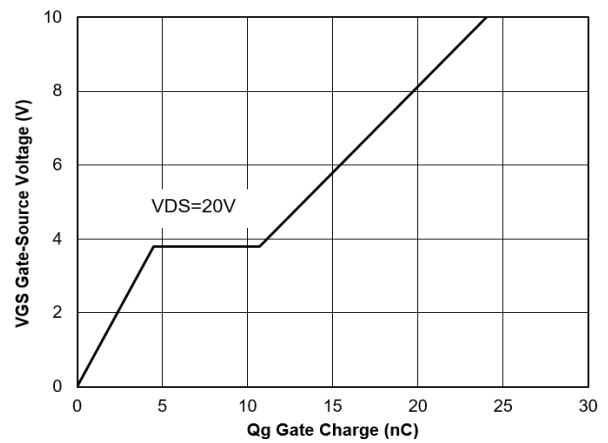

Figure 4. Gate Charge

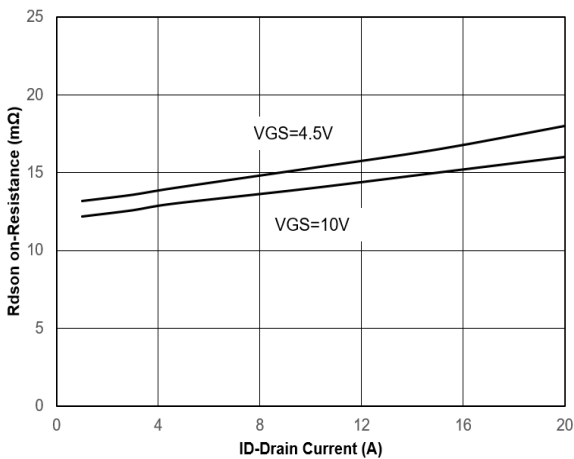

Figure 5. Drain-Source on Resistance

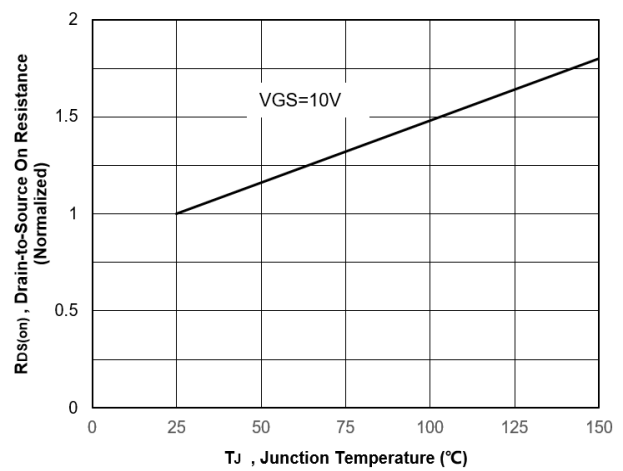

Figure 6. Normalized On-Resistance Vs. Temperature

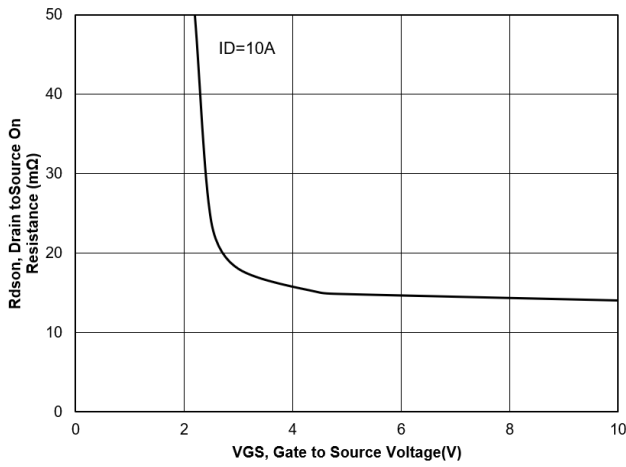

Figure 7. Typical Drain to Source ON Resistance VS Gate Voltage and Drain Current

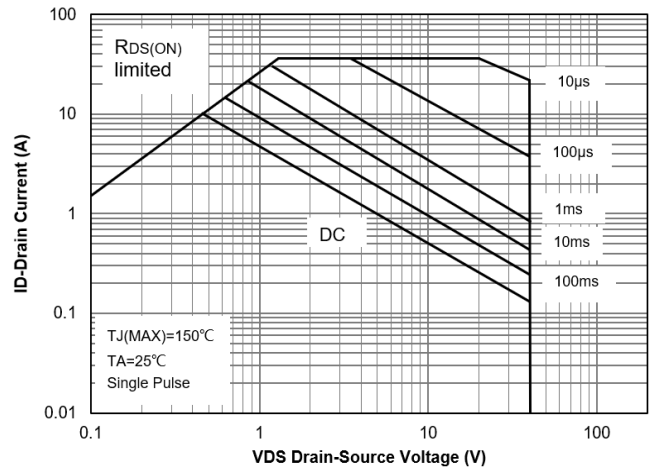

Figure 8. Safe Operation Area

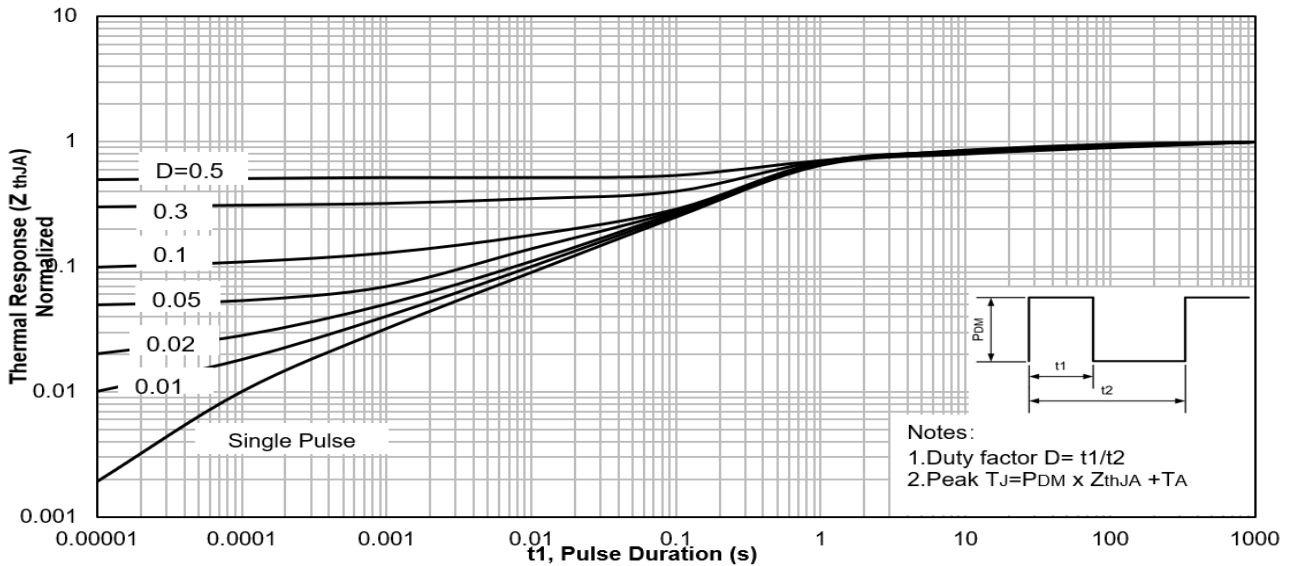

Figure 9. Maximum Effective Transient Thermal Impedance ,Junction-to-Ambient

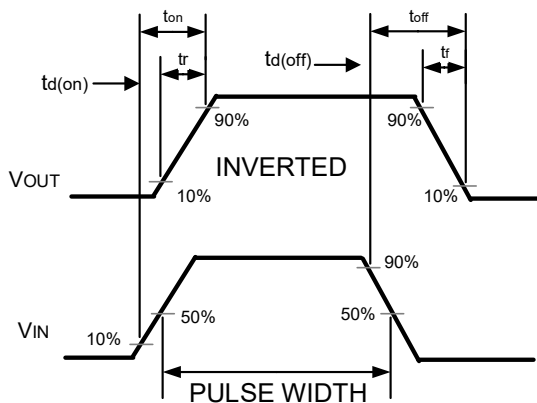
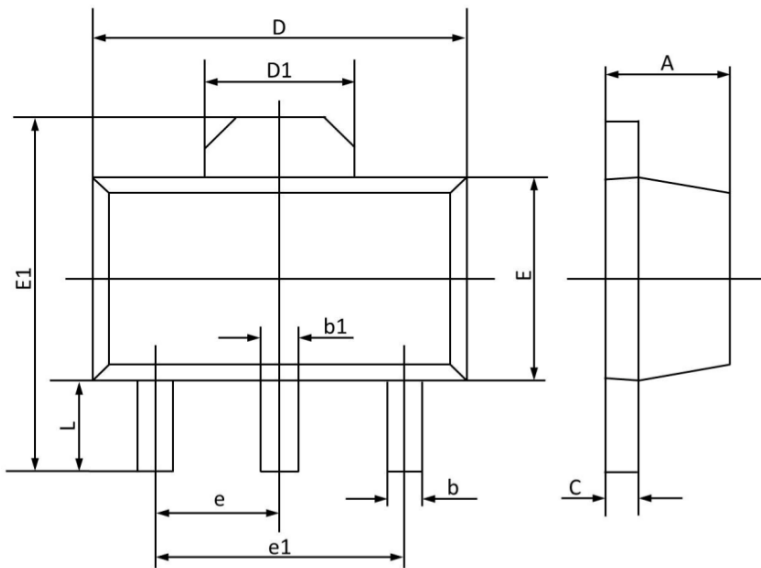

Figure 10. Switching wave

SOT-89 Package Outline Drawing



SYM	DIMENSIONS					
	MILLIMETERS			INCHES		
	MIN	NOM	MAX	MIN	NOM	MAX
A	1.400	--	1.600	0.055	--	0.063
b	0.320	--	0.520	0.013	--	0.020
b1	0.400	--	0.580	0.016	--	0.041
c	0.350	--	0.440	0.014	--	0.017
D	4.400	--	4.600	0.173	--	0.181
D1	1.550 REF			0.061 REF		
E	2.300	--	2.600	0.091	--	0.102
E1	3.940	--	4.250	0.155	--	0.167
e	1.500 TYP			0.060 TYP		
e1	3.000 TYP			0.118 TYP		
L	0.900	--	1.200	0.035	--	0.047

Contact Information

Applied Power Microelectronics Inc.

Website: <http://www.appliedpowermicro.com>

Email: sales@appliedpowermicro.com

Phone: +86 (0519) 8399 3606