

Description

The CM80N06GU is the N-Channel enhancement mode power field effect transistors with high cell density, high voltage planar technology. This high density process and design have been optimized switching performance and especially tailored to minimize on-state resistance.

Features

- V_{DS} : 60V
- I_D : 70A
- $R_{DS(ON)}$ (@ $V_{GS}=10V$): < 9.8m Ω
- High density cell design for extremely low $R_{DS(ON)}$
- Excellent on-resistance and DC current capability

Applications

- AC/DC load switch
- SMPS
- Notebooks and Handhelds adapter
- UPS Power

Marking Information



Marking Code = CM80N06GU

Date Code = XXXX

Equivalent Circuit and Pin Configuration

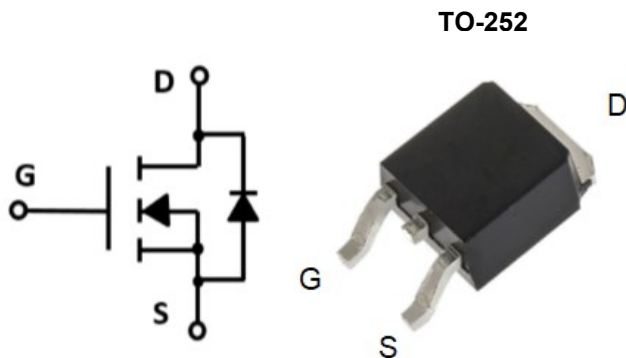

Ordering Information

P/N	Packaging	Remark
CM80N06GU	2500/Tape and Reel	ROHS

Absolute Maximum Ratings ($T_c=25^\circ\text{C}$ unless otherwise noted)

Parameter	Symbol	Maximum	Unit
Drain-source Voltage	V_{DS}	60	V
Gate-source Voltage	V_{GS}	± 20	V
Continuous Drain Current ⁽¹⁾	I_D	$T_c=25^\circ\text{C}$	70
		$T_c=100^\circ\text{C}$	45
Pulsed Drain Current ⁽²⁾	I_{DM}	280	A
Total Power Dissipation ⁽³⁾	P_D	$T_c=25^\circ\text{C}$	75
		Derating Factor above 25°C	0.6
Thermal Resistance Junction-to-Case ⁽³⁾	$R_{\theta JC}$	1.67	$^\circ\text{C/W}$
Junction and Storage Temperature Range	T_J, T_{STG}	-55 to +150	$^\circ\text{C}$

Electrical Characteristics (T_c=25 °C unless otherwise noted)

Parameter	Symbol	Conditions	Min	Typ	Max	Units
Static Parameter						
Drain-Source Breakdown Voltage	BVDSS	V _{GS} =0V, I _D =250μA	60			V
Zero Gate Voltage Drain Current	I _{DSS}	V _{DS} =60V, V _{GS} =0V, T _C =25°C			1	μA
Gate-Body Leakage Current	I _{GSS}	V _{GS} =±20V, V _{DS} =0V			±100	nA
Gate Threshold Voltage	V _{GS(th)}	V _{DS} =V _{GS} , I _D =250μA	1.0		3.0	V
Static Drain-Source on-Resistance	R _{DS(on)}	V _{GS} =10V, I _D =15A		6.0	7.5	mΩ
		V _{GS} =4.5V, I _D =10A		7.5	9.8	
Diode Forward Voltage	V _{SD}	I _S =20A, V _{GS} =0V			1.2	V
Maximum Body-Diode Continuous Current	I _S				70	A
Dynamic Parameters						
Input Capacitance	C _{iss}	V _{DS} =30V, V _{GS} =0V, f=1.0MHz		1990		pF
Output Capacitance	C _{oss}			410		
Reverse Transfer Capacitance	C _{rss}			15		
Switching Parameters						
Total Gate Charge	Q _g	V _{DS} =30V, I _D =25A, V _{GS} =10V		32		nC
Gate Source Charge	Q _{gs}			5.5		
Gate Drain Charge	Q _{gd}			6.4		
Turn-on Delay Time	t _{D(on)}	V _{GS} =10V, V _{DD} =30V, R _L =1Ω, R _{GEN} =3Ω		10		ns
Turn-on Rise Time	t _r			5		
Turn-off Delay Time	t _{D(off)}			30		
Turn-off Fall Time	t _f			8		

Noted: (1) Pulse Test: Pulse Width ≤ 300us, Duty cycle ≤ 2%.

(2) Pulse width limited by maximum junction temperature

(3) Device mounted on FR-4 PCB, 1 inch x 0.85 inch x 0.062 inch. With 2oz Copper, t ≤ 10s

Typical Performance Characteristics

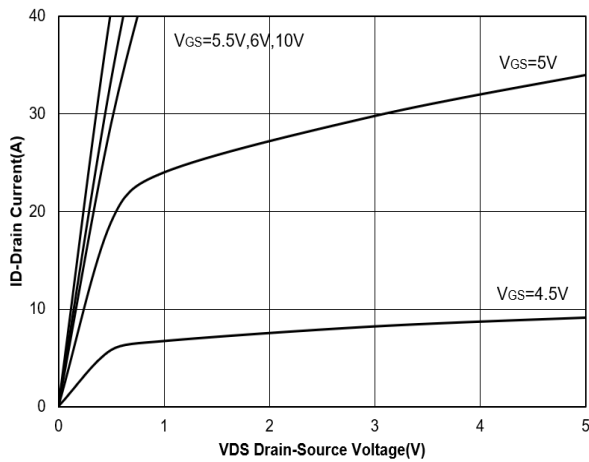

Figure 1. Output Characteristics

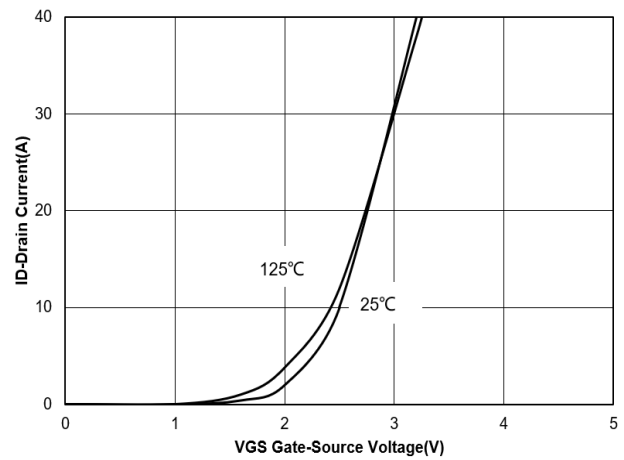

Figure 2. Transfer Characteristics

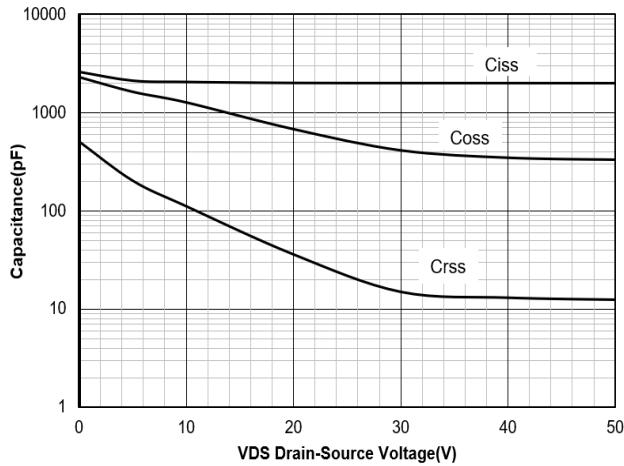

Figure 3. Capacitance Characteristics

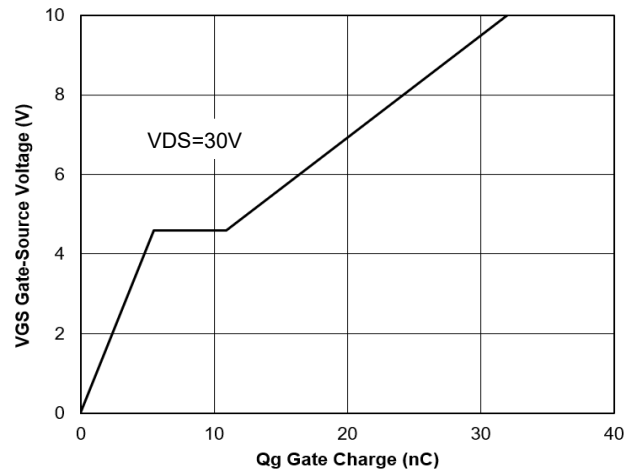

Figure 4. Gate Charge

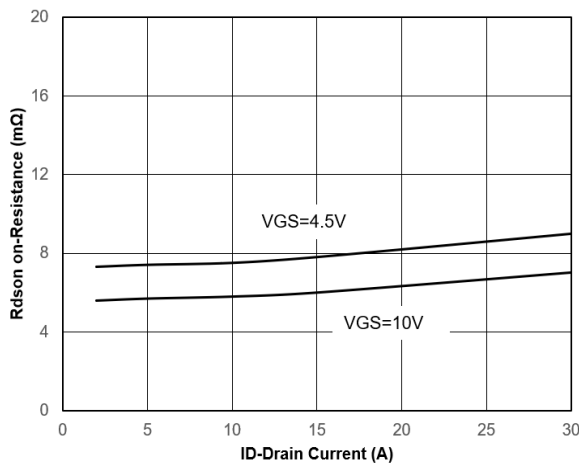

Figure 5. Drain-Source on Resistance

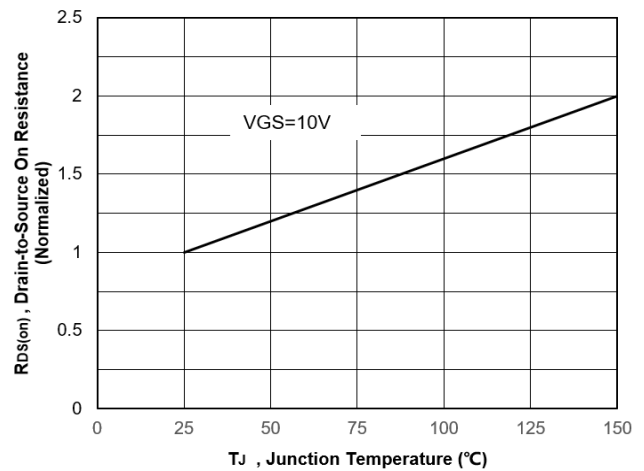

Figure 6. Normalized On-Resistance Vs. Temperature

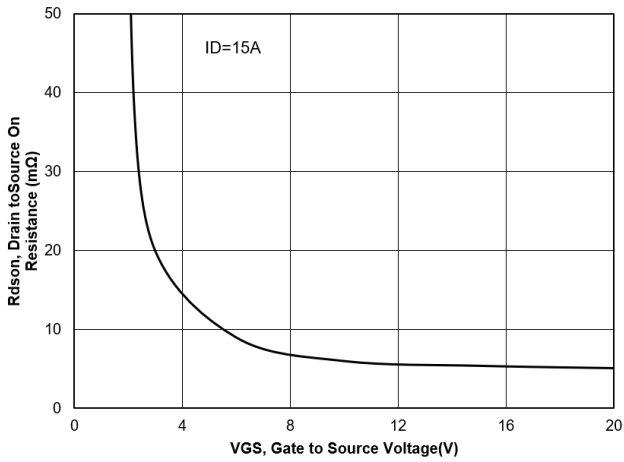

Figure 7. Typical Drain to Source ON Resistance VS Gate Voltage and Drain Current

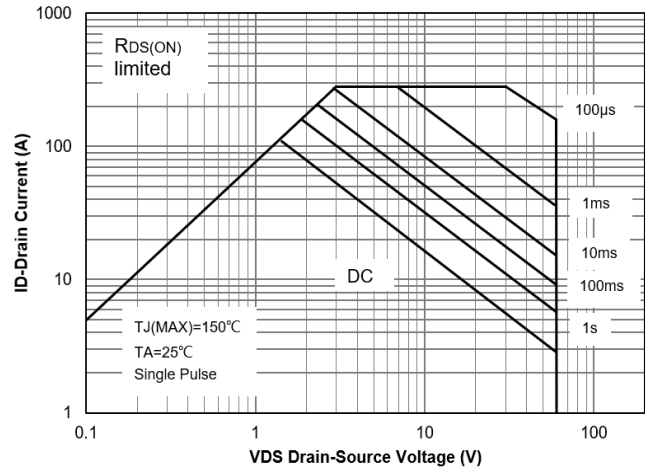

Figure 8. Safe Operation Area

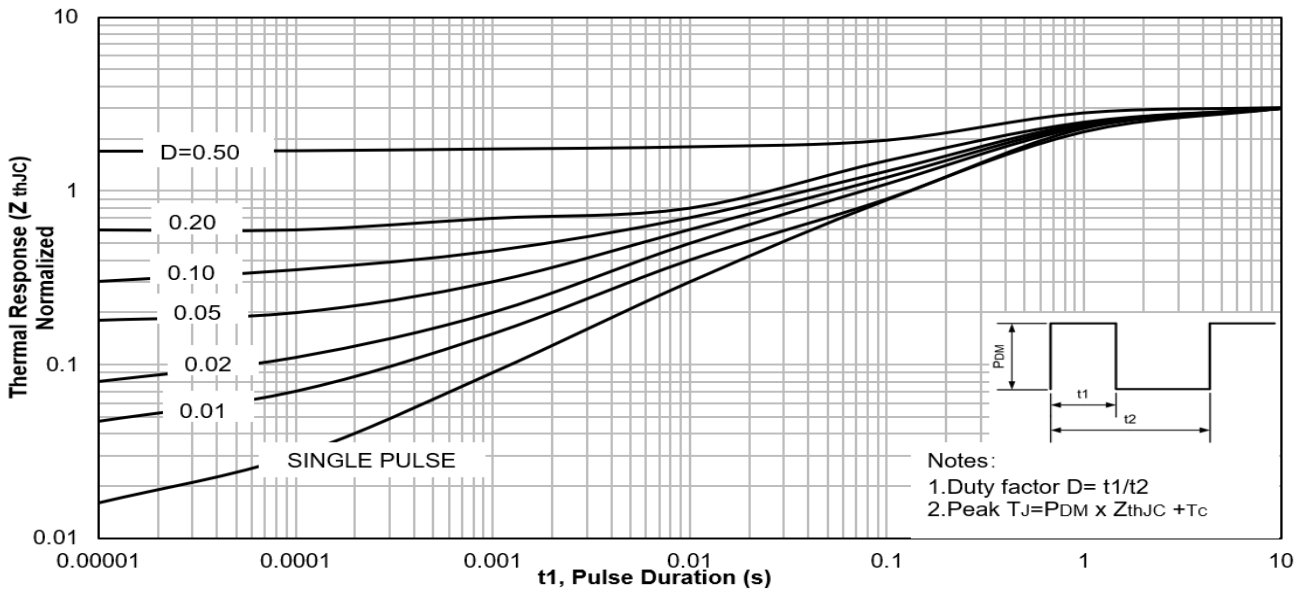

Figure 9. Maximum Effective Transient Thermal Impedance ,Junction-to-Case

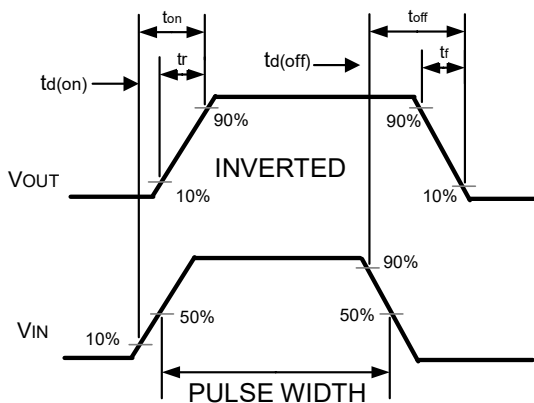
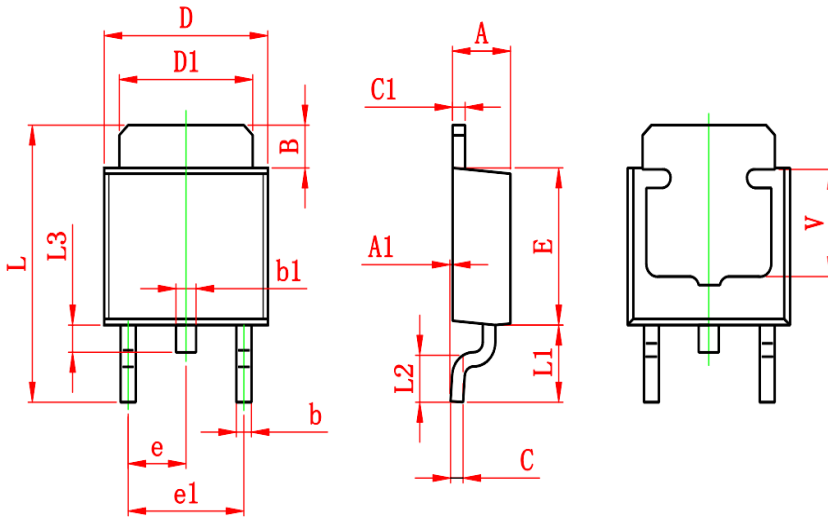

Figure 10. Switching wave

TO-252 Package Outline Drawing



Symbol	Millimeters		Inches	
	Min.	Max.	Min.	Max.
A	2.200	2.400	0.087	0.094
A1	0.000	0.127	0.000	0.005
B	1.350	1.650	0.053	0.065
b	0.500	0.700	0.020	0.028
b1	0.700	0.900	0.028	0.035
c	0.430	0.580	0.017	0.023
c1	0.430	0.580	0.017	0.023
D	6.350	6.650	0.250	0.262
D1	5.200	5.400	0.205	0.213
E	5.400	5.700	0.213	0.224
e	2.300 TYP.		0.091 TYP.	
e1	4.500	4.700	0.177	0.185
L	9.500	9.900	0.374	0.390
L1	2.550	2.900	0.100	0.114
L2	1.400	1.780	0.055	0.070
L3	0.600	0.900	0.024	0.035
V	3.800 REF.		0.150 REF.	

Contact Information

Applied Power Microelectronics Inc.

Website: <http://www.appliedpowermicro.com>

Email: sales@appliedpowermicro.com

Phone: +86 (0519) 8399 3606