

Description

CM3139AK is the P-Channel enhancement mode power field effect transistors with high cell density, trench technology. This high density process and design have been optimized switching performance and especially tailored to minimize on-state resistance.

Features

- V_{DS} : -20V
- I_D : -0.5A
- $R_{DS(on)}$ (@ $V_{GS}=-4.5V$): < 850m Ω
- $R_{DS(on)}$ (@ $V_{GS}=-2.5V$): < 1200m Ω
- High density cell design for extremely low $R_{DS(on)}$
- Excellent on-resistance and DC current capability

Equivalent Circuit and Pin Configuration

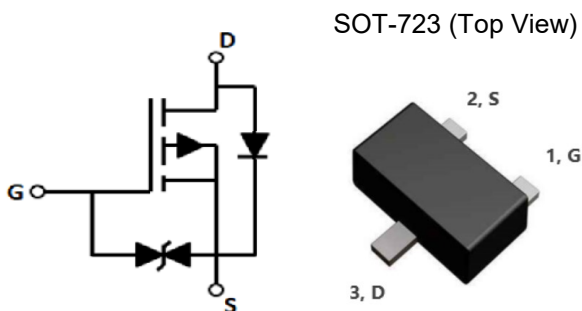

Applications

- Cellular Handsets and Accessories
- Personal Digital Assistants
- Portable Instrumentation
- Load switch

Marking Information

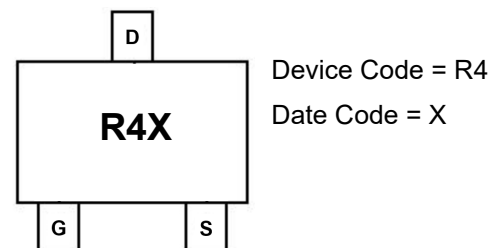

Ordering Information

Part Number	Packaging	Reel Size
CM3139AK	8000/Tape & Reel	7 inch

Absolute Maximum Ratings (TA=25 °C unless otherwise noted)

Parameter		Symbol	Maximum	Unit
Drain-source Voltage		V_{DS}	-20	V
Gate-source Voltage		V_{GS}	± 10	V
Continuous Drain Current	$T_A=25^\circ\text{C}$, Steady State	I_D	-0.5	A
	$T_A=75^\circ\text{C}$, Steady State		-0.4	A
Pulsed Drain Current ⁽¹⁾		I_{DM}	-2	A
Total Power Dissipation @ $T_A=25^\circ\text{C}$ ⁽²⁾ @Steady State		P_D	310	mW
Thermal Resistance Junction-to-Ambient ⁽²⁾ @Steady State		$R_{\theta JA}$	400	$^\circ\text{C/W}$
Junction and Storage Temperature Range		T_J, T_{STG}	-55 to +150	$^\circ\text{C}$

Electrical Characteristics (T_J=25 °C unless otherwise noted)

Parameter	Symbol	Conditions	Min	Typ	Max	Units
Static Parameter						
Drain-Source Breakdown Voltage	BV _{DSS}	V _{GS} =0V, I _D =-250μA	-20			V
Zero Gate Voltage Drain Current	I _{DSS}	V _{DS} =-20V, V _{GS} =0V, T _C =25°C			-1	μA
Gate-Body Leakage Current	I _{GSS}	V _{GS} =±10V, V _{DS} =0V			±10	uA
Gate Threshold Voltage	V _{GS(th)}	V _{DS} =V _{GS} , I _D =-250μA	-0.35		-1.2	V
Static Drain-Source on-Resistance	R _{DS(on)}	V _{GS} =-4.5V, I _D =-0.5A		610	850	mΩ
		V _{GS} =-2.5V, I _D =-0.3A		930	1200	
Diode Forward Voltage	V _{SD}	I _S =-0.5A, V _{GS} =0V			-1.2	V
Maximum Body-Diode Continuous Current	I _S				-0.5	A
Dynamic Parameters						
Input Capacitance	C _{iss}	V _{DS} =-10V, V _{GS} =0V, f=1MHz		36		pF
Output Capacitance	C _{oss}			12		
Reverse Transfer Capacitance	C _{rss}			7.5		
Switching Parameters						
Total Gate Charge	Q _g	V _{GS} =-4.5V, V _{DS} =-10V, I _D =-0.5A		1.22		nC
Gate Source Charge	Q _{gs}			0.36		
Gate Drain Charge	Q _{gd}			0.26		
Turn-on Delay Time	t _{D(on)}	V _{GS} =-4.5V, V _{DD} =-10V, R _L =2.5Ω, R _{GEN} =3Ω		16		ns
Turn-on Rise Time	t _r			11.8		
Turn-off Delay Time	t _{D(off)}			26.4		
Turn-off Fall Time	t _f			8.3		

Noted: (1) Pulse Test: Pulse Width ≤ 300us, Duty cycle ≤ 2%.

(2) Surface mounted on FR4 board using the minimum recommended pad size.

Typical Performance Characteristics

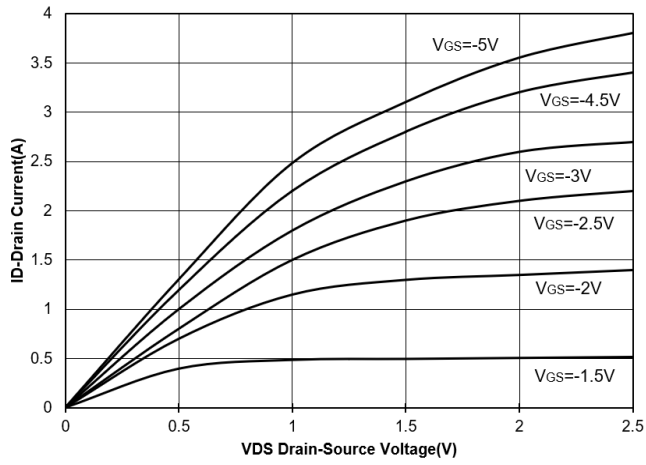

Figure 1. Output Characteristics

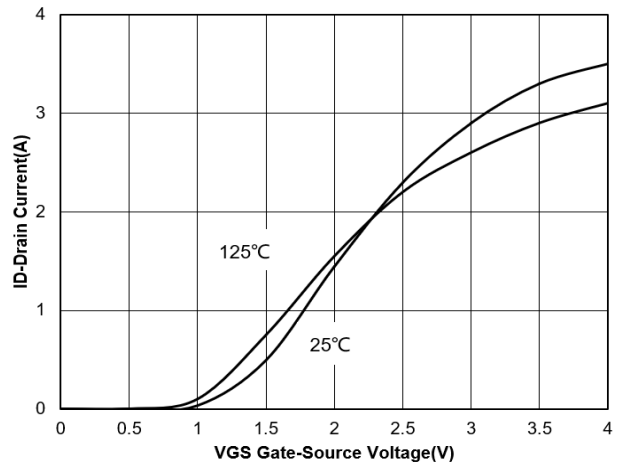

Figure 2. Transfer Characteristics

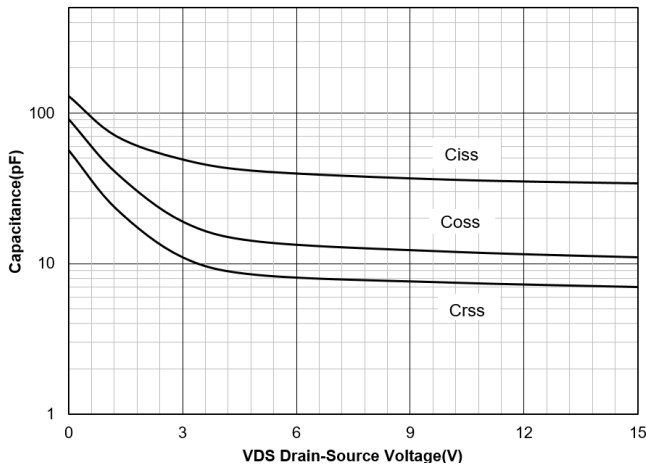

Figure 3. Capacitance Characteristics

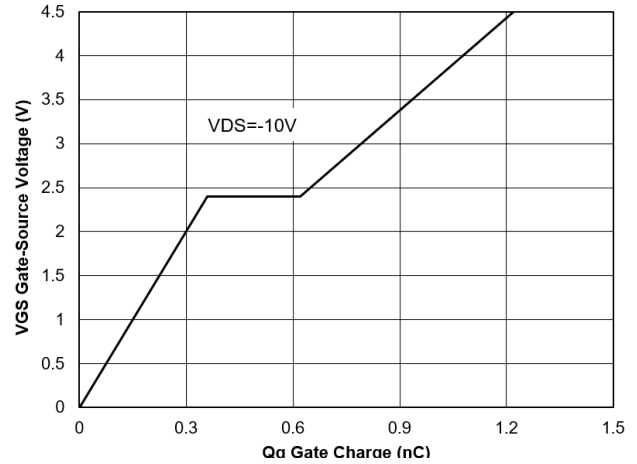

Figure 4. Gate Charge

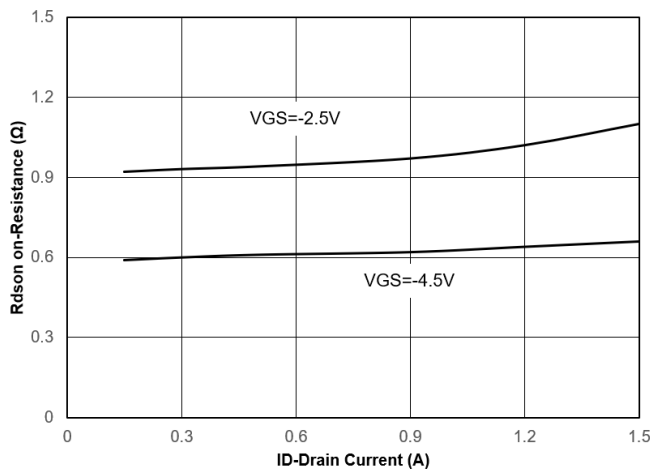

Figure 5. Drain-Source on Resistance

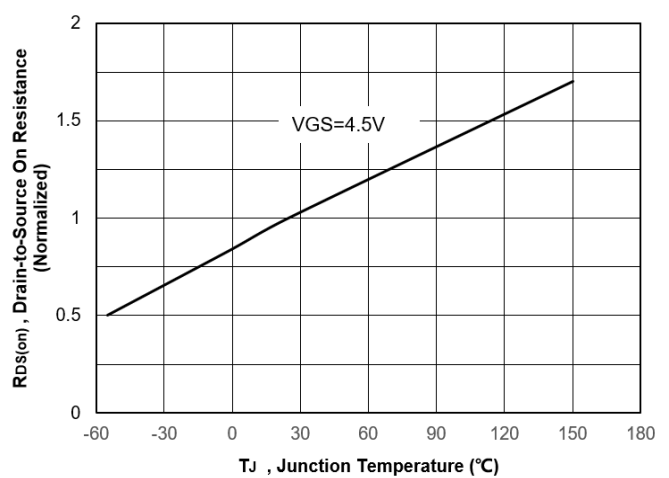

Figure 6. Normalized On-Resistance Vs. Temperature

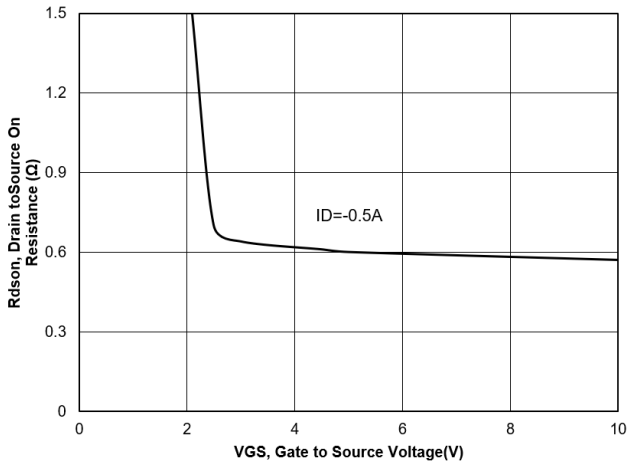

Figure 7. Typical Drain to Source ON Resistance VS Gate Voltage and Drain Current

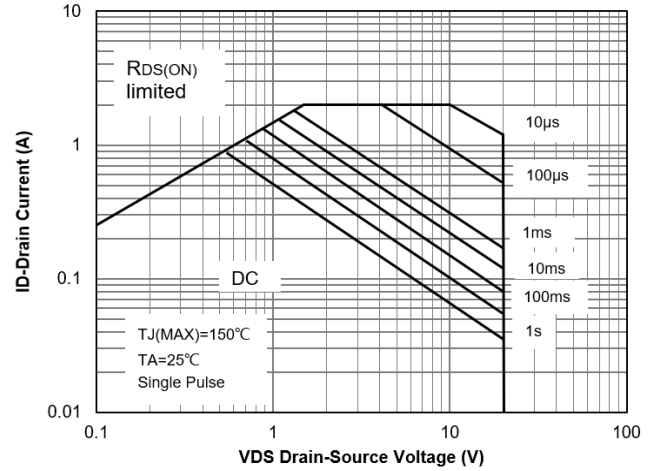

Figure 8. Safe Operation Area

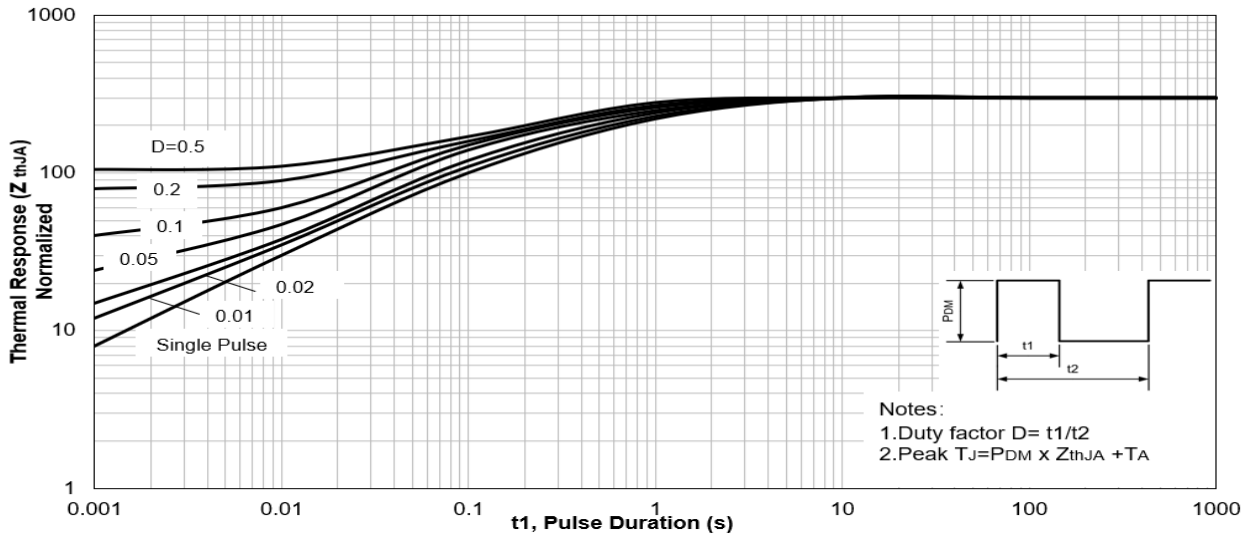

Figure 9. Maximum Effective Transient Thermal Impedance ,Junction-to-Ambient

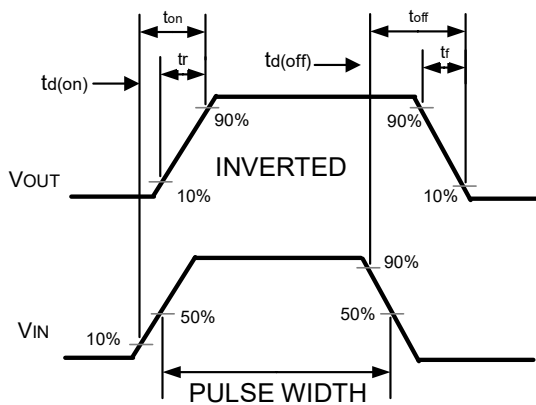
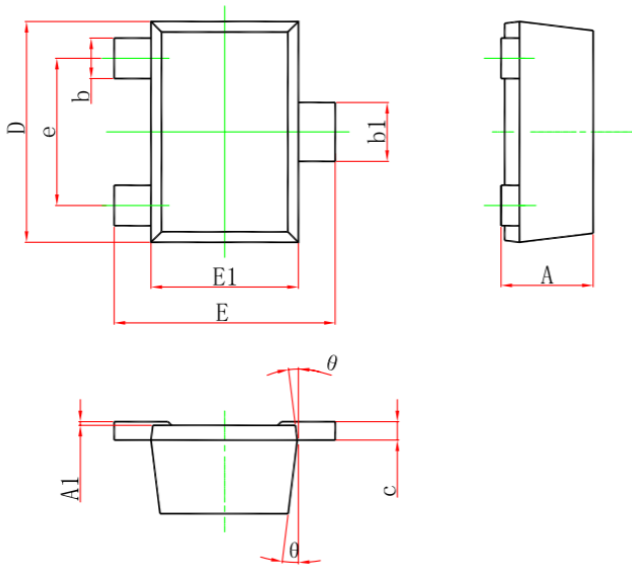

Figure 10. Switching wave

SOT-723 Package Outline Drawing



SYM	DIMENSIONS			
	MILLIMETERS		INCHES	
	MIN	MAX	MIN	MAX
A	0.430	0.500	0.017	0.020
A1	0.000	0.050	0.000	0.002
b	0.170	0.270	0.007	0.011
b1	0.270	0.370	0.011	0.015
c	0.080	0.150	0.003	0.006
D	1.150	1.250	0.045	0.049
E	1.150	1.250	0.045	0.049
E1	0.750	0.850	0.030	0.033
e	0.800 TYP.		0.800 TYP.	
θ	7° REF.		7° REF.	

Suggested Land Pattern

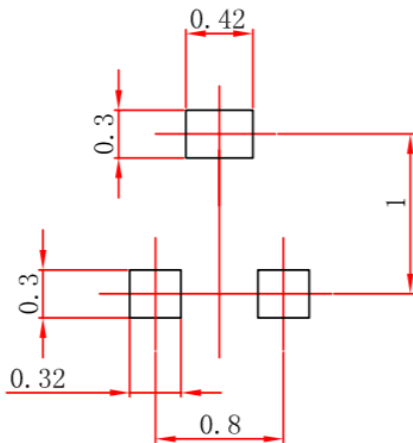

Contact Information

Applied Power Microelectronics Inc.

Website: <http://www.appliedpowermicro.com>

Email: sales@appliedpowermicro.com

Phone: +86 (0519) 8399 3606