

Description

CM3134K is the N-Channel enhancement mode power field effect transistors with high cell density, trench technology. This high density process and design have been optimized switching performance and especially tailored to minimize on-state resistance.

Features

- V_{DS} : 20V
- I_D : 0.86A
- $R_{DS(on)}$ (@ $V_{GS}=4.5V$) : < 250m Ω
- $R_{DS(on)}$ (@ $V_{GS}=2.5V$) : < 350m Ω
- High density cell design for extremely low $R_{DS(on)}$
- Excellent on-resistance and DC current capability

Equivalent Circuit and Pin Configuration

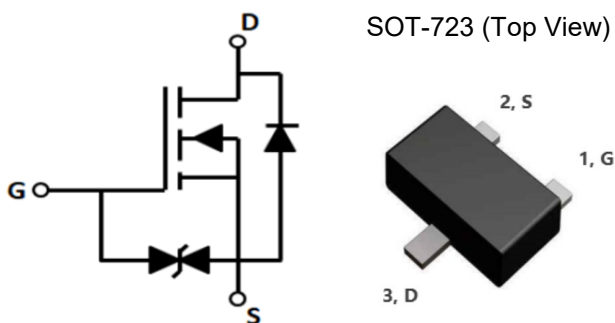

Applications

- Cellular Handsets and Accessories
- Personal Digital Assistants
- Portable Instrumentation
- Load switch

Marking Information

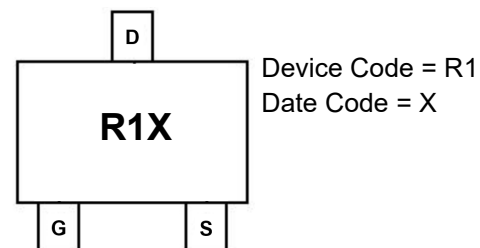

Ordering Information

Part Number	Packaging	Reel Size
CM3134K	8000/Tape & Reel	7 inch

Absolute Maximum Ratings (TA=25 °C unless otherwise noted)

Parameter		Symbol	Maximum	Unit
Drain-source Voltage		V_{DS}	20	V
Gate-source Voltage		V_{GS}	± 10	V
Continuous Drain Current	$T_A=25^\circ\text{C}$, Steady State	I_D	0.86	A
	$T_A=75^\circ\text{C}$, Steady State		0.66	A
Pulsed Drain Current ⁽¹⁾		I_{DM}	3.0	A
Total Power Dissipation @ $T_A=25^\circ\text{C}$ ⁽²⁾ @Steady State		PD	310	mW
Thermal Resistance Junction-to-Ambient ⁽²⁾ @Steady State		$R_{\theta JA}$	400	$^\circ\text{C/W}$
Junction and Storage Temperature Range		T_J, T_{STG}	-55 to +150	$^\circ\text{C}$

Electrical Characteristics (T_J=25 °C unless otherwise noted)

Parameter	Symbol	Conditions	Min	Typ	Max	Units
Static Parameter						
Drain-Source Breakdown Voltage	BV _{DSS}	V _{GS} =0V, I _D =250μA	20			V
Zero Gate Voltage Drain Current	I _{DSS}	V _{DS} =20V, V _{GS} =0V, T _C =25°C			1	μA
Gate-Body Leakage Current	I _{GSS}	V _{GS} =±10V, V _{DS} =0V			±10	uA
Gate Threshold Voltage	V _{GS(th)}	V _{DS} =V _{GS} , I _D =250μA	0.35	0.75	1.1	V
Static Drain-Source on-Resistance	R _{DS(on)}	V _{GS} =4.5V, I _D =0.5A		170	250	mΩ
		V _{GS} =2.5V, I _D =0.3A		225	350	
Diode Forward Voltage	V _{SD}	I _S =0.86A, V _{GS} =0V			1.2	V
Maximum Body-Diode Continuous Current	I _S				0.86	A
Dynamic Parameters						
Input Capacitance	C _{iss}	V _{DS} =16V, V _{GS} =0V, f=1MHz		49		pF
Output Capacitance	C _{oss}			9.4		
Reverse Transfer Capacitance	C _{rss}			5.5		
Switching Parameters						
Turn-on Delay Time	t _{D(on)}	V _{GS} =4.5V, V _{DD} =10V, I _D =0.5A, R _{GEN} =10Ω		6.7		ns
Turn-on Rise Time	t _r			4.8		
Turn-off Delay Time	t _{D(off)}			17.3		
Turn-off Fall Time	t _f			7.4		

Noted: (1) Pulse Test: Pulse Width ≤ 300us, Duty cycle ≤ 2%.

(2) Surface mounted on FR4 board using the minimum recommended pad size.

Typical Performance Characteristics

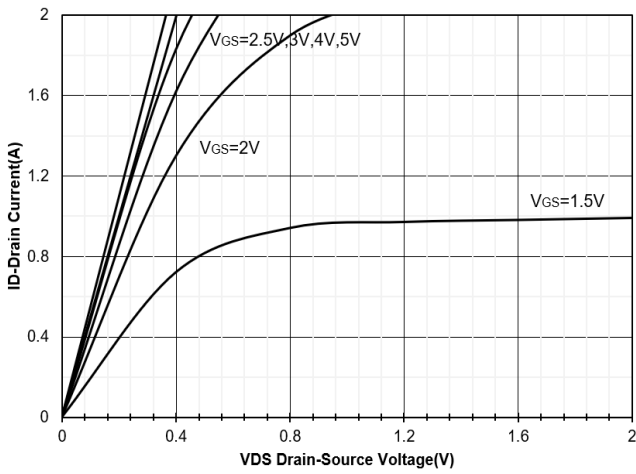

Figure 1. Output Characteristics

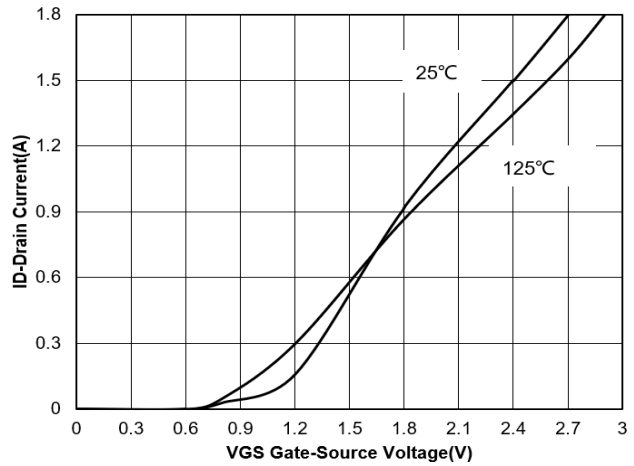

Figure 2. Transfer Characteristics

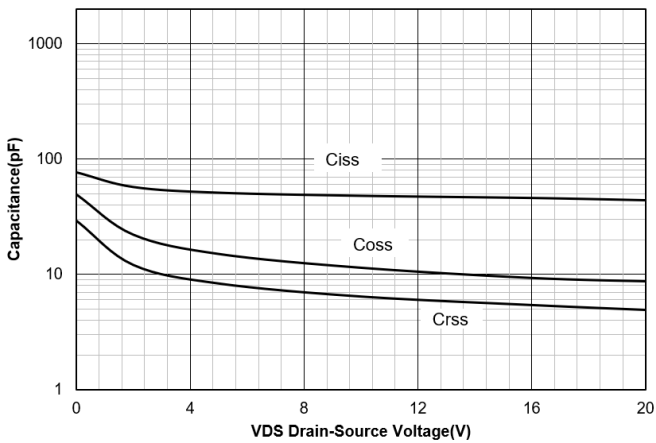

Figure 3. Capacitance Characteristics

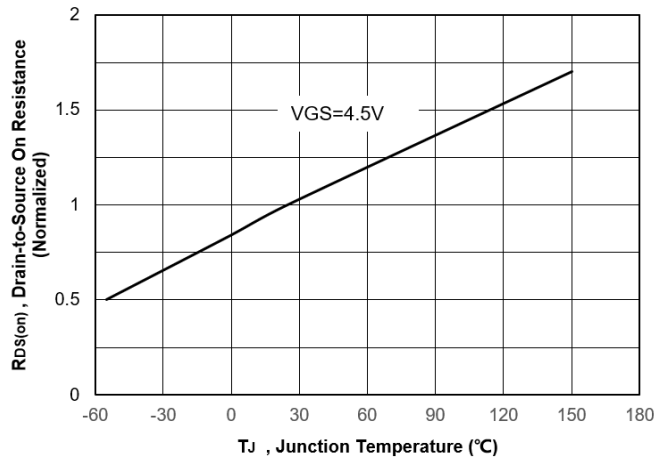

Figure 4. Normalized On-Resistance Vs. Temperature

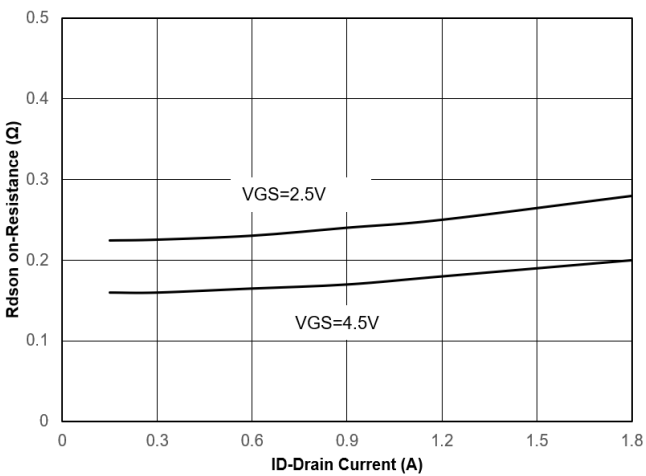

Figure 5. Drain-Source on Resistance

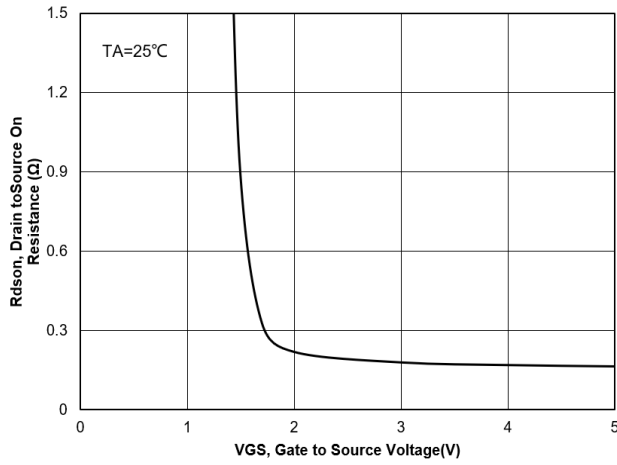

Figure 6. Typical Drain to Source ON Resistance VS Gate Voltage and Drain Current

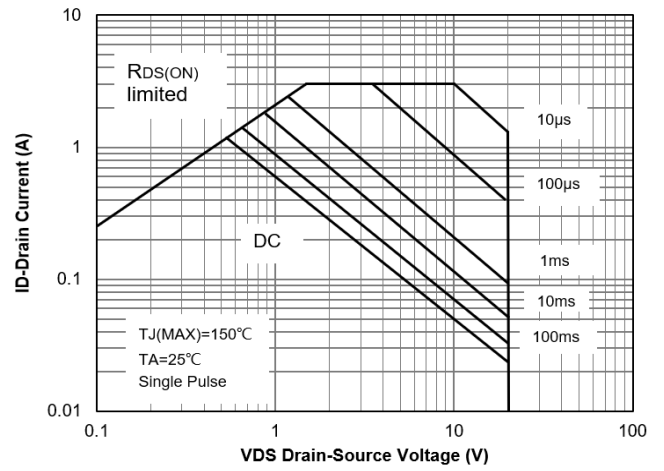

Figure 7. Safe Operation Area

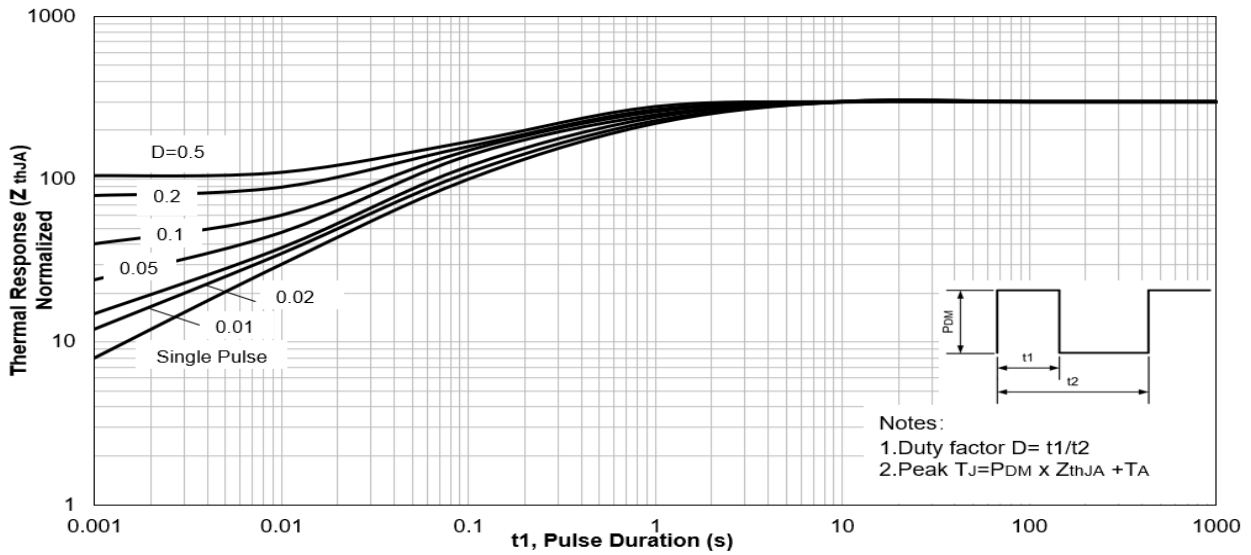

Figure 8. Maximum Effective Transient Thermal Impedance ,Junction-to-Ambient

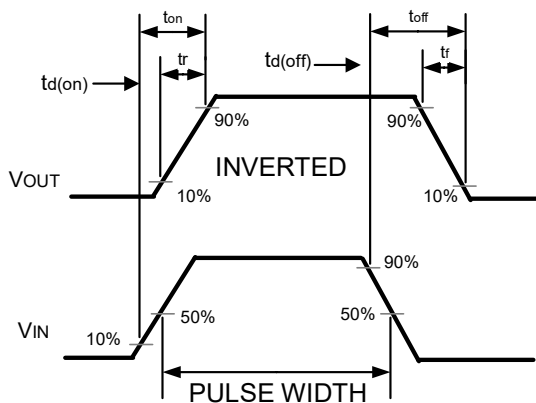
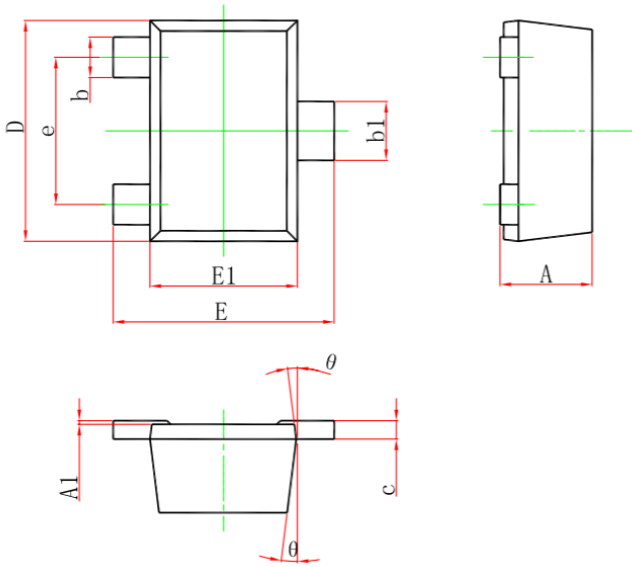

Figure 9. Switching wave

SOT-723 Package Outline Drawing

(Unit : mm)



SYM	DIMENSIONS			
	MILLIMETERS		INCHES	
	MIN	MAX	MIN	MAX
A	0.430	0.500	0.017	0.020
A1	0.000	0.050	0.000	0.002
b	0.170	0.270	0.007	0.011
b1	0.270	0.370	0.011	0.015
c	0.080	0.150	0.003	0.006
D	1.150	1.250	0.045	0.049
E	1.150	1.250	0.045	0.049
E1	0.750	0.850	0.030	0.033
e	0.800 TYP.		0.800 TYP.	
θ	7° REF.		7° REF.	

Suggested Land Pattern

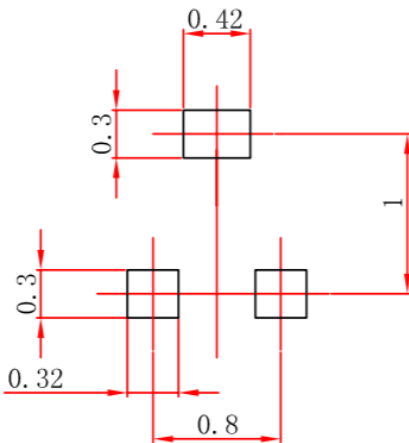

Contact Information

Applied Power Microelectronics Inc.

 Website: <http://www.appliedpowermicro.com>

 Email: sales@appliedpowermicro.com

Phone: +86 (0519) 8399 3606