

Description

CM1601A is the P-Channel enhancement mode power field effect transistors with high cell density, trench technology. This high density process and design have been optimized switching performance and especially tailored to minimize on-state resistance.

Features

- V_{DS} : -20V
- I_D : -0.56A
- $R_{DS(on)}$ (@ $V_{GS}=-4.5V$): < 850m Ω
- $R_{DS(on)}$ (@ $V_{GS}=-2.5V$): < 1200m Ω
- High density cell design for extremely low $R_{DS(on)}$
- Excellent on-resistance and DC current capability

Equivalent Circuit and Pin Configuration

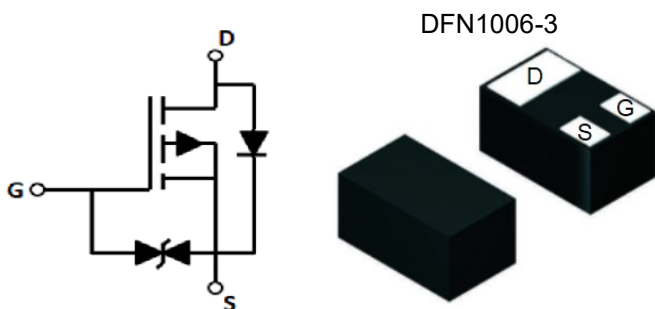

Applications

- Cellular Handsets and Accessories
- Personal Digital Assistants
- Portable Instrumentation
- Load switch

Marking Information

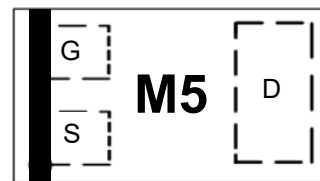

Marking Code = M5

Ordering Information

Part Number	Packaging	Reel Size
CM1601A	10000/Tape & Reel	7 inch

Absolute Maximum Ratings (TA=25 °C unless otherwise noted)

Parameter	Symbol	Maximum	Unit	
Drain-source Voltage	V_{DS}	-20	V	
Gate-source Voltage	V_{GS}	± 10	V	
Continuous Drain Current	I_D	$T_A=25^\circ\text{C}$, $t \leq 5\text{s}$	-0.56	A
		$T_A=25^\circ\text{C}$, Steady State	-0.5	A
		$T_A=75^\circ\text{C}$, Steady State	-0.39	A
Pulsed Drain Current ⁽¹⁾	I_{DM}	-2.24	A	
Total Power Dissipation @ $T_A=25^\circ\text{C}$ ⁽²⁾	P_D	$t \leq 5\text{s}$	430	mW
		Steady State	340	
Thermal Resistance Junction-to-Ambient ⁽²⁾ @ $t \leq 5\text{s}$	$R_{\theta JA}$	294	$^\circ\text{C/W}$	
Thermal Resistance Junction-to-Ambient ⁽²⁾ @Steady State		366		
Junction and Storage Temperature Range	T_J, T_{STG}	-55 to +150	$^\circ\text{C}$	

Electrical Characteristics (T_J=25 °C unless otherwise noted)

Parameter	Symbol	Conditions	Min	Typ	Max	Units
Static Parameter						
Drain-Source Breakdown Voltage	BV _{DSS}	V _{GS} =0V, I _D =-250μA	-20			V
Zero Gate Voltage Drain Current	I _{DSS}	V _{DS} =-20V, V _{GS} =0V, T _C =25°C			-1	μA
Gate-Body Leakage Current	I _{GSS}	V _{GS} =±10V, V _{DS} =0V			±10	uA
Gate Threshold Voltage	V _{GS(th)}	V _{DS} =V _{GS} , I _D =-250μA	-0.35		-1.2	V
Static Drain-Source on-Resistance	R _{DS(on)}	V _{GS} =-4.5V, I _D =-0.5A		610	850	mΩ
		V _{GS} =-2.5V, I _D =-0.3A		930	1200	
Diode Forward Voltage	V _{SD}	I _S =-0.56A, V _{GS} =0V			-1.2	V
Maximum Body-Diode Continuous Current	I _S				-0.56	A
Dynamic Parameters						
Input Capacitance	C _{iss}	V _{DS} =-10V, V _{GS} =0V, f=1MHz		70		pF
Output Capacitance	C _{oss}			19		
Reverse Transfer Capacitance	C _{rss}			14		
Switching Parameters						
Total Gate Charge	Q _g	V _{GS} =-4.5V, V _{DS} =-10V, I _D =-0.5A		1.22		nC
Gate Source Charge	Q _{gs}			0.36		
Gate Drain Charge	Q _{gd}			0.26		
Turn-on Delay Time	t _{D(on)}	V _{GS} =-4.5V, V _{DD} =-10V, R _L =2.5Ω, R _{GEN} =2.5Ω		4.5		ns
Turn-on Rise Time	t _r			18		
Turn-off Delay Time	t _{D(off)}			15		
Turn-off Fall Time	t _f			23		

Noted: (1) Pulse Test: Pulse Width ≤ 300us, Duty cycle ≤ 2%.

(2) Device mounted on FR-4 PCB, 1 inch x 0.85 inch x 0.062 inch. With 2oz Copper, t ≤ 10s

Typical Performance Characteristics

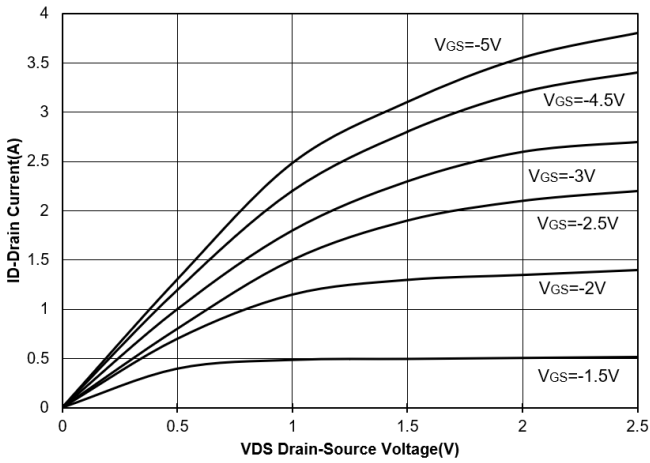

Figure 1. Output Characteristics

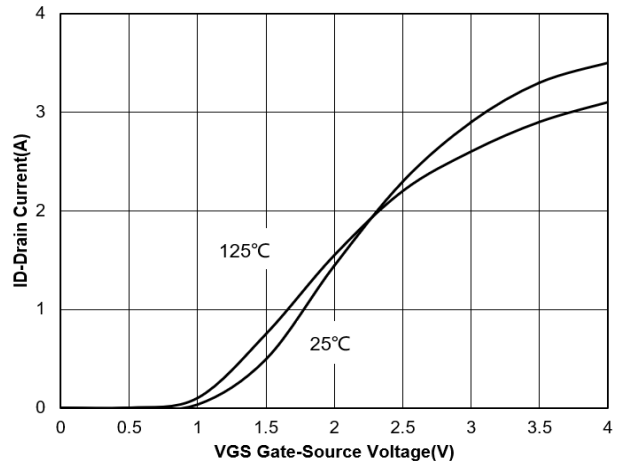

Figure 2. Transfer Characteristics

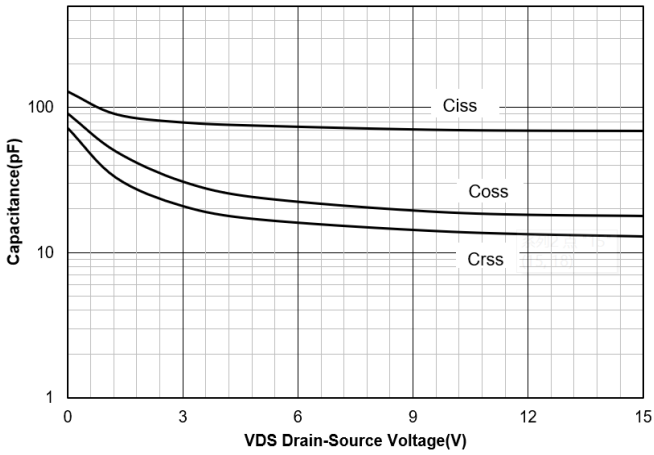

Figure 3. Capacitance Characteristics

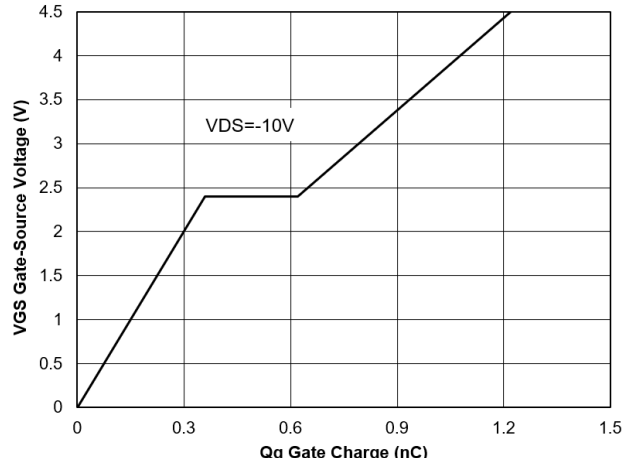

Figure 4. Gate Charge

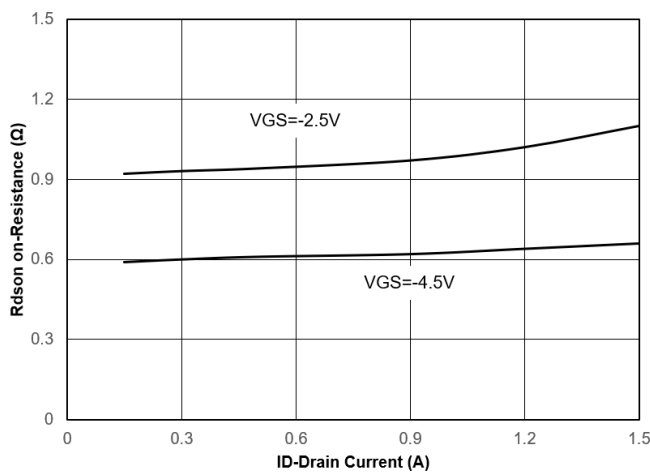

Figure 5. Drain-Source on Resistance

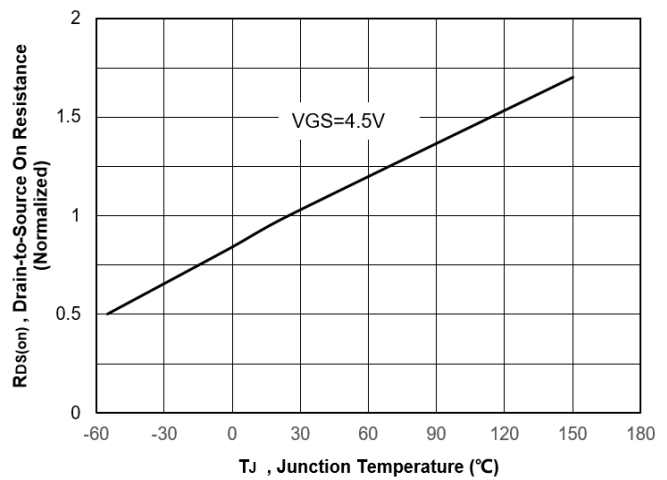

Figure 6. Normalized On-Resistance Vs. Temperature

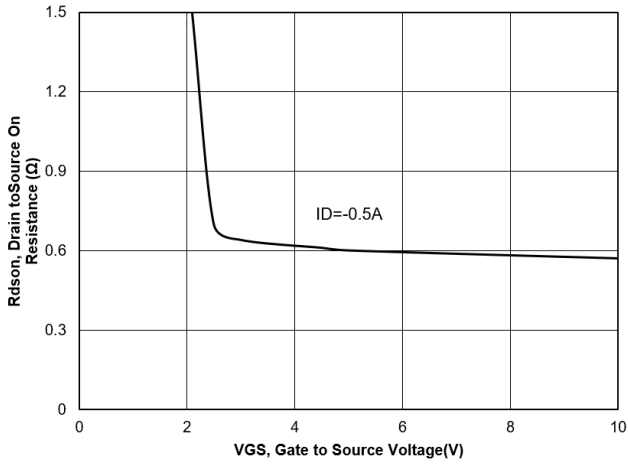

Figure 7. Typical Drain to Source ON Resistance VS Gate Voltage and Drain Current

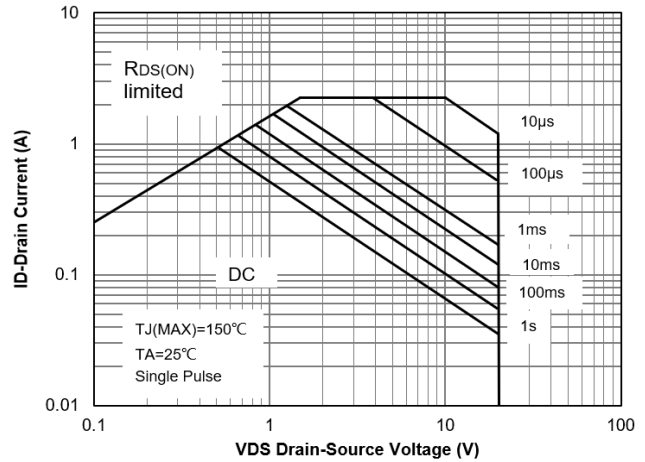

Figure 8. Safe Operation Area

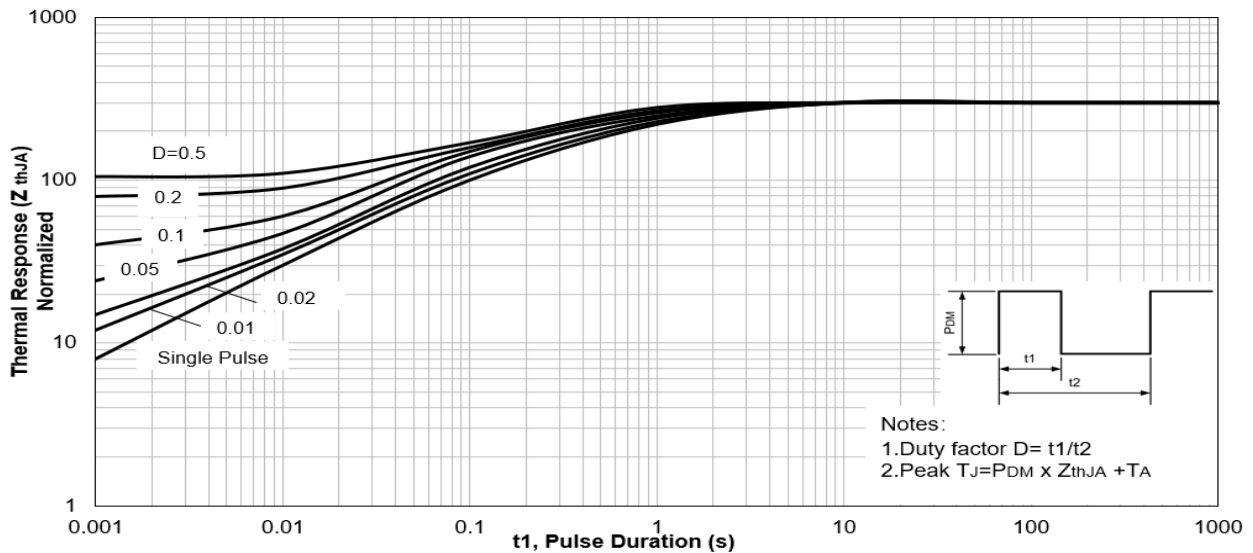

Figure 9. Maximum Effective Transient Thermal Impedance ,Junction-to-Ambient

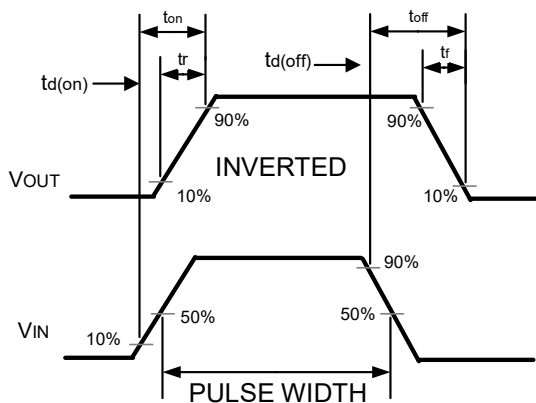
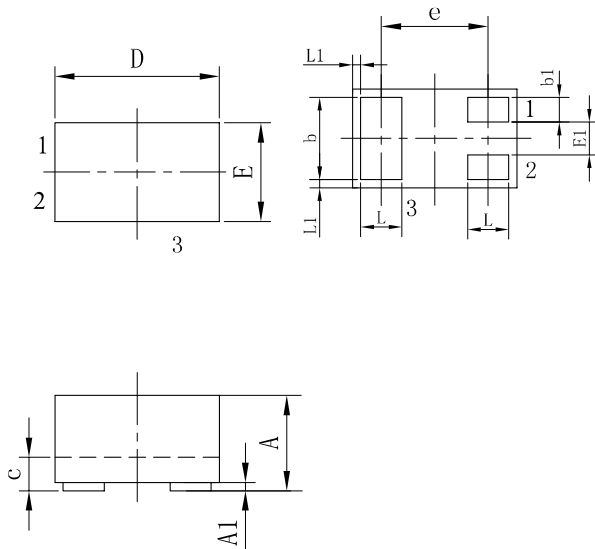

Figure 10. Switching wave

DFN1006-3 Package Outline Drawing



SYM	DIMENSIONS					
	MILLIMETERS			INCHES		
	MIN	NOM	MAX	MIN	NOM	MAX
A	0.45	0.50	0.55	0.018	0.020	0.022
A1	0.00	0.02	0.05	0.000	0.001	0.002
b	0.45	0.50	0.55	0.018	0.020	0.022
b1	0.10	0.15	0.20	0.004	0.006	0.008
c	0.12	0.15	0.18	0.005	0.006	0.007
D	0.95	1.00	1.05	0.037	0.039	0.041
e	0.65 BSC			0.026 BSC		
E	0.55	0.60	0.65	0.022	0.024	0.026
E1	0.15	0.20	0.25	0.006	0.008	0.010
L	0.20	0.25	0.30	0.008	0.010	0.012
L1	0.05 REF			0.0002 REF		

Suggested Land Pattern

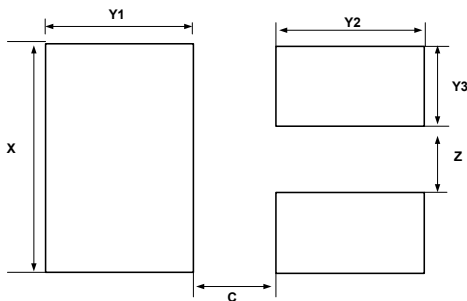

SYM	DIMENSIONS	
	MILLIMETERS	INCHES
C	0.25	0.010
X	0.65	0.024
Y1	0.50	0.020
Y2	0.50	0.020
Y3	0.25	0.010
Z	0.20	0.008

Contact Information

Applied Power Microelectronics Inc.

Website: <http://www.appliedpowermicro.com>

Email: sales@appliedpowermicro.com

Phone: +86 (0519) 8399 3606