

Description

The CM12N65P/F is the N-Channel enhancement mode power field effect transistors with high cell density, high voltage planar technology. This high density process and design have been optimized switching performance and especially tailored to minimize on-state resistance.

Features

- VDS: 650V
- ID (@VGS=10V): 12A
- RDS_{ON} (@VGS=10V) : < 0.78Ω
- High density cell design for extremely low RDS_{ON}
- Excellent on-resistance and DC current capability

Applications

- AC/DC load switch
- SMPS
- LED power

Marking Information

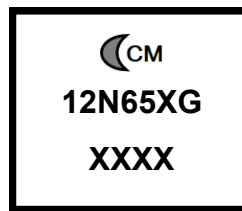

X=Package type
 G=Halogen Free
 XXXX = Marking Code

Equivalent Circuit and Pin Configuration

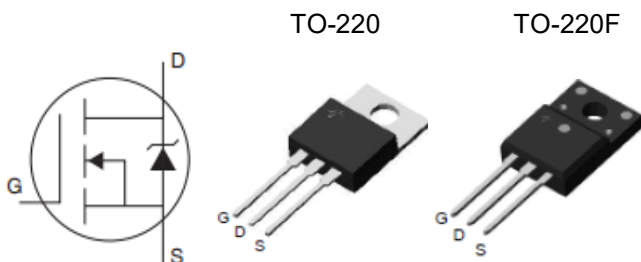

Ordering Information

P/N	Package Type	Packaging	Remark
CM12N65P	TO-220	Tube	ROHS
CM12N65PG	TO-220	Tube	Halogen Free
CM12N65F	TO-220F	Tube	ROHS
CM12N65FG	TO-220F	Tube	Halogen Free

Absolute Maximum Ratings (Tc=25 °C unless otherwise noted)

Parameter	Symbol	Maximum		Unit	
		CM12N65P	CM12N65F		
Drain-source Voltage	V _{DS}	650		V	
Gate-source Voltage	V _{GS}	±30		V	
Continuous Drain Current ⁽¹⁾	I _D	T _c =25°C	12	12 ⁽⁴⁾	A
		T _c =100°C	7.6	7.6 ⁽⁴⁾	A
Pulsed Drain Current ⁽²⁾	I _{DM}	48	48 ⁽⁴⁾	A	
Total Power Dissipation ⁽³⁾	P _d @ T _c =25°C	223	52	W	
	Derating Factor above 25°C	1.79	0.42	W/°C	
Thermal Resistance Junction-to-Case ⁽³⁾	R _{θJC}	0.56	2.4	°C/W	
Junction and Storage Temperature Range	T _J ,T _{STG}	-55 to +150		°C	

Electrical Characteristics (T_c=25 °C unless otherwise noted)

Parameter	Symbol	Conditions	Min	Typ	Max	Units
Static Parameter						
Drain-Source Breakdown Voltage	B _V D _{SS}	V _{GS} =0V, I _D =250μA	650			V
Zero Gate Voltage Drain Current	I _{DSS}	V _{DS} =650V, V _{GS} =0V, T _C =25°C			1	μA
Gate-Body Leakage Current	I _{GSS}	V _{GS} =±30V, V _{DS} =0V			±100	nA
Gate Threshold Voltage	V _{GS(th)}	V _{DS} =V _{GS} , I _D =250μA	2.0		4.0	V
Static Drain-Source on-Resistance	R _{DS(on)}	V _{GS} =10V, I _D =6A		0.6	0.78	Ω
Diode Forward Voltage	V _{SD}	I _S =12A, V _{GS} =0V			1.2	V
Maximum Body-Diode Continuous Current	I _S				12	A
Dynamic Parameters						
Input Capacitance	C _{iss}	V _{DS} =25V, V _{GS} =0V, f=1MHz		1970		pF
Output Capacitance	C _{oss}			158		
Reverse Transfer Capacitance	C _{rss}			3		
Switching Parameters						
Total Gate Charge	Q _g	V _{DS} =520V, I _D =10A, V _{GS} =10V		39		nC
Gate Source Charge	Q _{gs}			9.2		
Gate Drain Charge	Q _{gd}			14.5		
Turn-on Delay Time	t _{D(on)}	V _{GS} =10V, V _{DD} =325V, I _D =10A, R _{GEN} =25Ω		65		ns
Turn-on Rise Time	t _r			38		
Turn-off Delay Time	t _{D(off)}			149		
Turn-off Fall Time	t _f			55		

Noted: (1) Pulse Test: Pulse Width ≤ 300us, Duty cycle ≤ 2%

(2) Pulse width limited by maximum junction temperature

(3) Device mounted on FR-4 PCB, 1 inch x 0.85 inch x 0.062 inch. With 2oz Copper, t ≤ 10s

(4) Drain current limited by maximum junction temperature

Typical Performance Characteristics

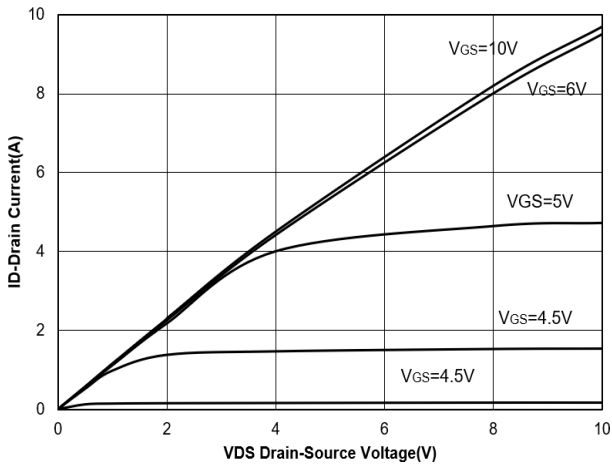

Figure 1. Output Characteristics

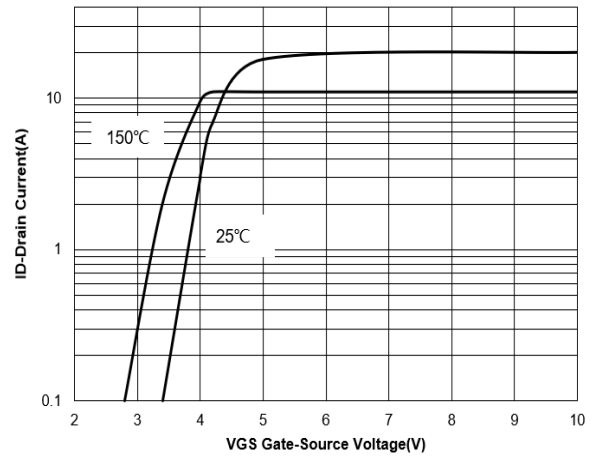

Figure 2. Transfer Characteristics

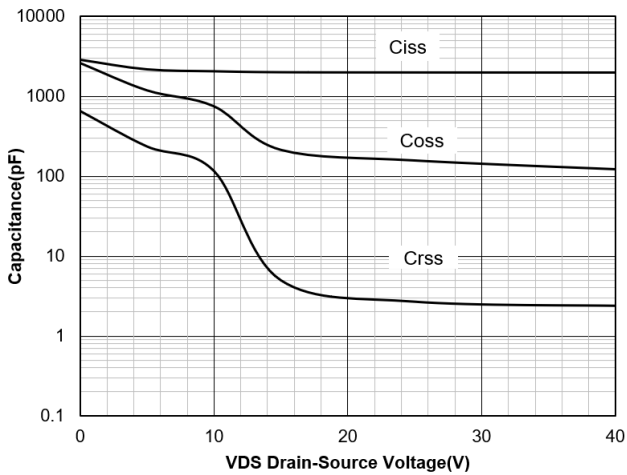

Figure 3. Capacitance Characteristics

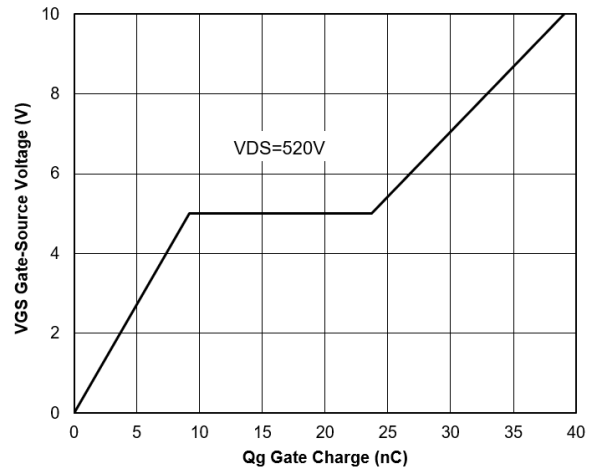

Figure 4. Gate Charge

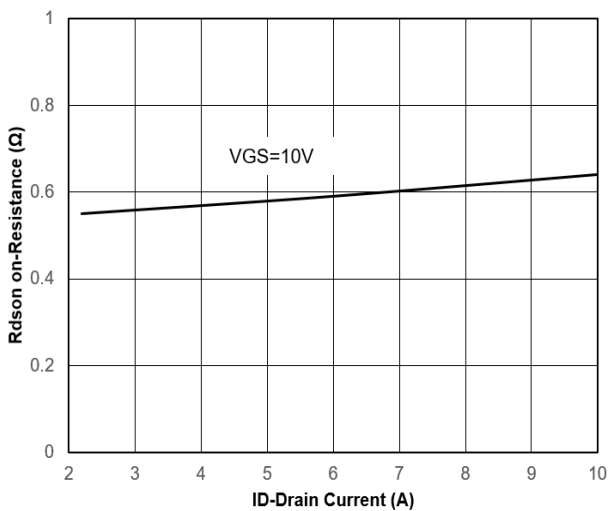

Figure 5. Drain-Source on Resistance

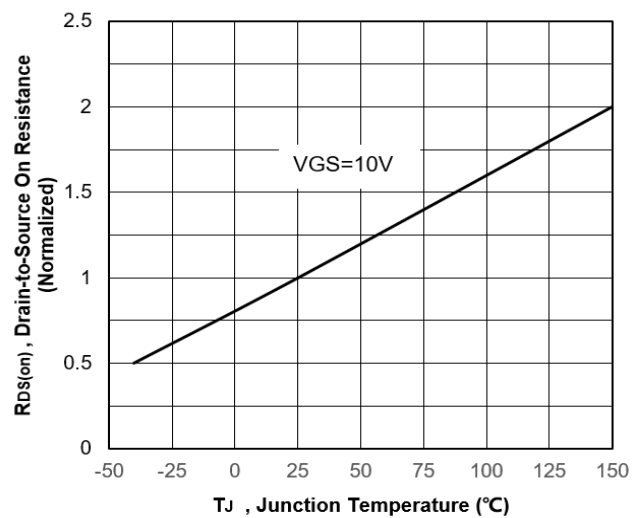

Figure 6. Normalized On-Resistance

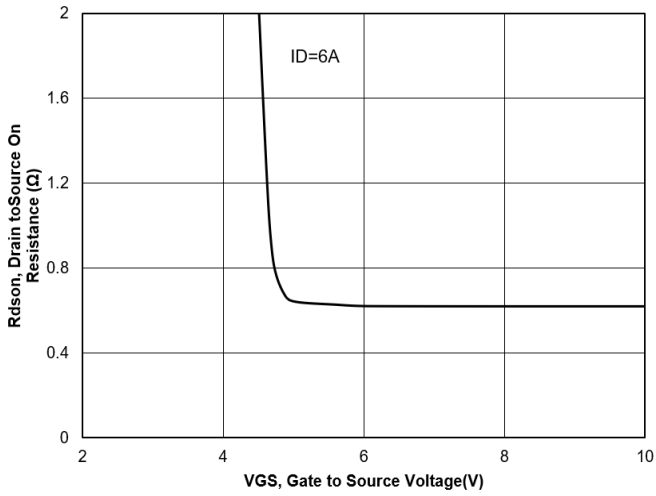

Figure 7. Typical Drain to Source ON Resistance VS Gate Voltage and Drain Current

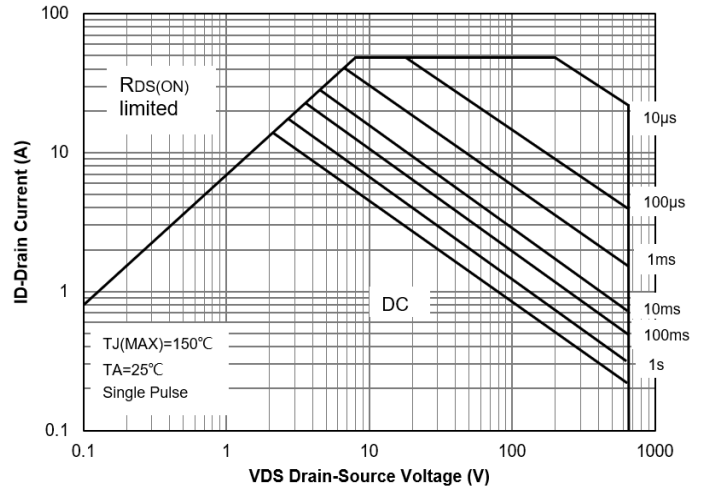

Figure 8. Safe Operation Area

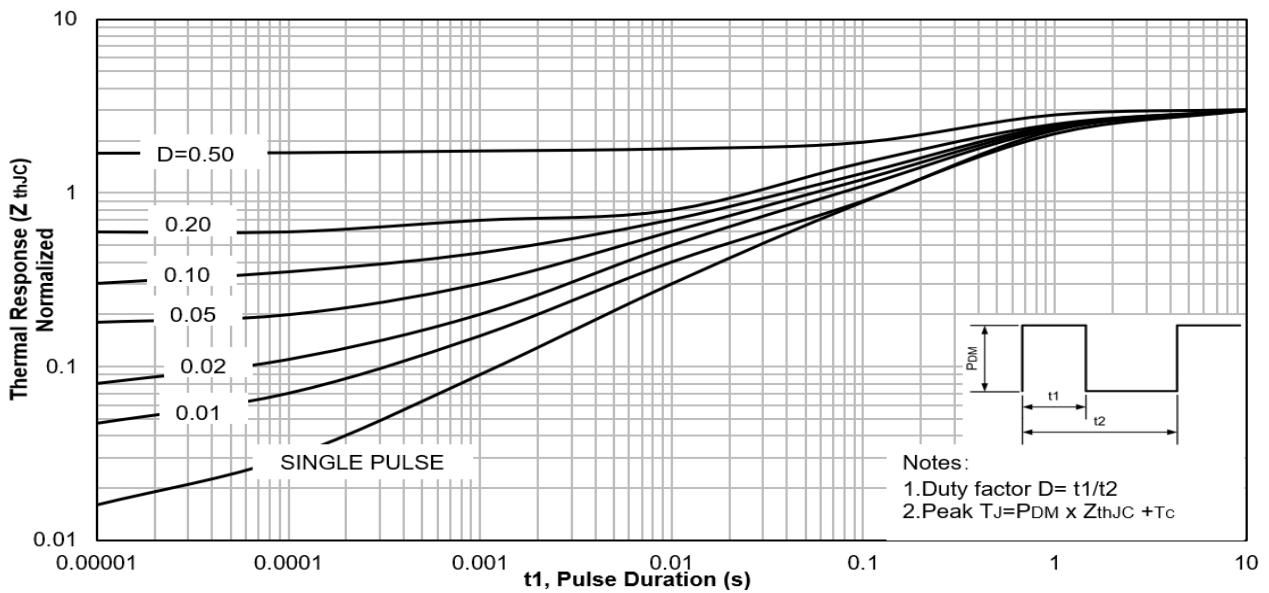

Figure 9. Maximum Effective Transient Thermal Impedance ,Junction-to-Case

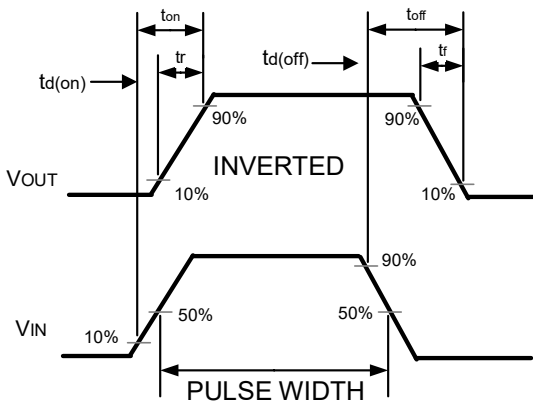
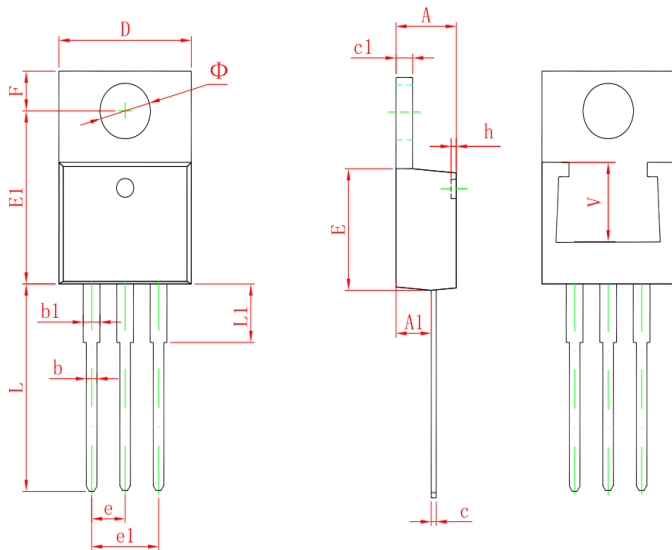

Figure 10. Switching wave

TO-220 Package Outline Drawing



Symbol	Millimeters		Inches	
	Min.	Max.	Min.	Max.
A	4.470	4.670	0.176	0.184
A1	2.520	2.820	0.099	0.111
b	0.710	0.910	0.028	0.036
b1	1.170	1.370	0.046	0.054
c	0.310	0.530	0.012	0.021
c1	1.170	1.370	0.046	0.054
D	10.010	10.310	0.394	0.406
E	8.500	8.900	0.335	0.350
E1	12.060	12.460	0.475	0.491
e	2.540 TYP.		0.100 TYP.	
e1	4.980	5.180	0.196	0.204
F	2.590	2.890	0.102	0.114
h	0.000	0.300	0.000	0.012
L	13.400	13.800	0.528	0.543
L1	3.560	3.960	0.140	0.156
Phi	3.735	3.935	0.147	0.155
V	5.600 REF.		0.220 REF.	

TO-220F Package Outline Drawing

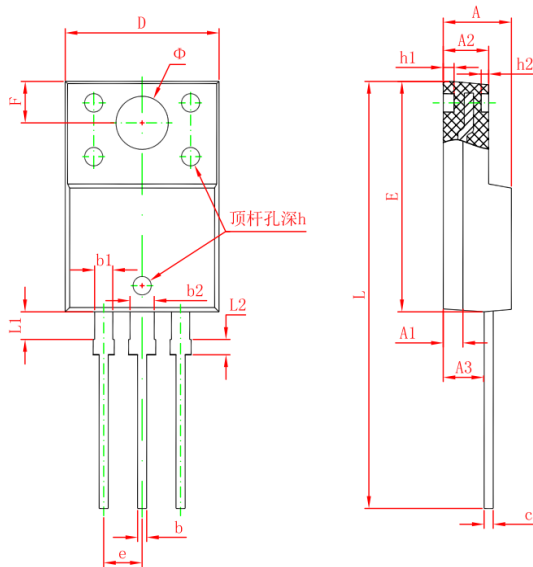

Symbol	Millimeters		Inches	
	Min.	Max.	Min.	Max.
A	4.300	4.700	0.169	0.185
A1	1.300 REF.		0.051 REF.	
A2	2.800	3.200	0.110	0.126
A3	2.500	2.900	0.098	0.114
b	0.500	0.750	0.020	0.030
b1	1.100	1.350	0.043	0.053
b2	1.500	1.750	0.059	0.069
c	0.500	0.750	0.020	0.030
D	9.960	10.360	0.392	0.408
E	14.800	15.200	0.583	0.598
e	2.540 TYP.		0.100 TYP.	
F	2.700 REF.		0.106 REF.	
Phi	3.500 REF.		0.138 REF.	
h	0.000	0.300	0.000	0.012
h1	0.800 REF.		0.031 REF.	
h2	0.500 REF.		0.020 REF.	
L	28.000	28.400	1.102	1.118
L1	1.700	1.900	0.067	0.075
L2	0.900	1.100	0.035	0.043

Contact Information

Applied Power Microelectronics Inc.

Website: <http://www.appliedpowermicro.com>

Email: sales@appliedpowermicro.com

Phone: +86 (0519) 8399 3606