

Description

The AUxx71P6 is an Uni-directional TVS diode, utilizing leading monolithic silicon technology to provide fast response time and low ESD clamping voltage, making this device an ideal solution for protecting voltage sensitive data and power line. The AUxx71P6 complies with the IEC 61000-4-2 (ESD) with $\pm 30\text{kV}$ air and $\pm 30\text{kV}$ contact discharge. It is assembled into an ultra-small 1.6x1.0x0.5mm lead-free DFN package. The small size and high ESD surge protection make AUxx71P6 an ideal choice to protect cell phone, digital cameras, audio players and many other portable applications.

Features

- Small package: 1.6x1.0x0.5mm
- Protects one data or power line
- Operating Voltage: 5V, 7V, 9V, 12V, 15V, 18V, 24V, 36V
- High peak pulse current capability
- Ultra low clamping voltage
- 2-pin leadless package
- Complies with following standards:
 - IEC 61000-4-2 (ESD) immunity test
Air discharge: $\pm 30\text{kV}$
Contact discharge: $\pm 30\text{kV}$
 - IEC 61000-4-5 (Lightning) 25-150A(8/20 μs)
- RoHS Compliant

Mechanical Characteristics

- Package: DFN1610-2
- Case Material: “Green” Molding Compound.
- Terminal Connections: See Diagram Below
- Marking Information: See Below

Applications

- Mobile Phones and Accessories
- Battery Protection
- USB VBus
- Power Line Protection
- Hand Held Portable Applications

Marking Information

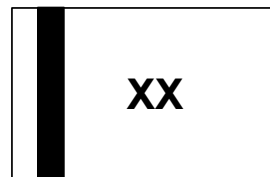

XX = Device Marking Code
Bar denotes Cathode

Ordering Information

Equivalent Circuit and Pin Configuration

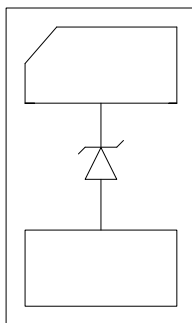

Circuit and Pin Schematic

VMPart Number	Marking	Packaging	Reel Size
AU0571P6	91	3000/Tape & Reel	7 inch
AU0771P6	76	3000/Tape & Reel	7 inch
AU0971P6	96	3000/Tape & Reel	7 inch
AU1271P6	72	3000/Tape & Reel	7 inch
AU1571P6	75	3000/Tape & Reel	7 inch
AU1871P6	78	3000/Tape & Reel	7 inch
AU2471P6	74	3000/Tape & Reel	7 inch
AU3671P6	79	3000/Tape & Reel	7 inch

Absolute Maximum Ratings ($T_A=25^\circ\text{C}$ unless otherwise specified)

Parameter	Symbol	Value	Unit
Peak Pulse Power (8/20 μs)	Ppk	1875	W
ESD per IEC 61000-4-2 (Air)	VESD	± 30	kV
ESD per IEC 61000-4-2 (Contact)		± 30	
Operating Temperature Range	TJ	-55 to +125	$^\circ\text{C}$
Storage Temperature Range	Tstg	-55 to +150	$^\circ\text{C}$

Electrical Characteristics ($T_A=25^\circ\text{C}$ unless otherwise specified)

AU0571P6						
Parameter	Symbol	Min	Typ	Max	Unit	Test Condition
Reverse Working Voltage	VRWM			5	V	
Breakdown Voltage	VBR	6			V	$I_T = 1\text{mA}$
Reverse Leakage Current	I_R			1.0	μA	VRWM = 5V
Forward Voltage	VF		1.0	1.2	V	$I_F = 10\text{mA}$
Peak Pulse Current	I _{PP}			125	A	$t_p = 8/20\mu\text{s}$
Clamping Voltage	VC			15	V	$I_{PP} = 90\text{A}$ (8 x 20 μs pulse)
Clamping Voltage	VC			17	V	$I_{PP} = 125\text{A}$ (8 x 20 μs pulse)
Junction Capacitance	CJ		960		pF	VR = 0V, f = 1MHz

AU0771P6						
Parameter	Symbol	Min	Typ	Max	Unit	Test Condition
Reverse Working Voltage	VRWM			7	V	
Breakdown Voltage	VBR	7.5			V	IT = 1mA
Reverse Leakage Current	IR			0.5	μA	VRWM = 7V
Forward Voltage	VF		1.0	1.2	V	IF = 10mA
Peak Pulse Current	I _{PP}			115	A	tp = 8/20μs
Clamping Voltage	VC			12	V	I _{PP} = 10A (8 x 20μs pulse)
Clamping Voltage	VC			18	V	I _{PP} = 115A (8 x 20μs pulse)
Junction Capacitance	CJ			550	pF	VR = 0V, f = 1MHz

AU0971P6						
Parameter	Symbol	Min	Typ	Max	Unit	Test Condition
Reverse Working Voltage	VRWM			9	V	
Breakdown Voltage	VBR	10			V	IT = 1mA
Reverse Leakage Current	IR			0.5	μA	VRWM = 9V
Forward Voltage	VF		1.0	1.2	V	IF = 10mA
Peak Pulse Current	I _{PP}			90	A	tp = 8/20μs
Clamping Voltage	VC			15	V	I _{PP} = 10A (8 x 20μs pulse)
Clamping Voltage	VC			23	V	I _{PP} = 90A (8 x 20μs pulse)
Junction Capacitance	CJ			525	pF	VR = 0V, f = 1MHz

AU1271P6						
Parameter	Symbol	Min	Typ	Max	Unit	Test Condition
Reverse Working Voltage	VRWM			12	V	
Breakdown Voltage	VBR	12.6			V	IT = 1mA
Reverse Leakage Current	IR			0.1	µA	VRWM = 12V
Forward Voltage	VF			1.2	V	IF = 10mA
Peak Pulse Current	I _{PP}			75	A	tp = 8/20µs
Clamping Voltage	VC			18	V	I _{PP} = 10A (8 x 20µs pulse)
Clamping Voltage	VC			25	V	I _{PP} = 75A (8 x 20µs pulse)
Junction Capacitance	CJ			500	pF	VR = 0V, f = 1MHz

AU1571P6						
Parameter	Symbol	Min	Typ	Max	Unit	Test Condition
Reverse Working Voltage	VRWM			15	V	
Breakdown Voltage	VBR	16.5			V	IT = 1mA
Reverse Leakage Current	IR			0.1	µA	VRWM = 15V
Forward Voltage	VF			1.2	V	IF = 10mA
Peak Pulse Current	I _{PP}			60	A	tp = 8/20µs
Clamping Voltage	VC			22	V	I _{PP} = 10A (8 x 20µs pulse)
Clamping Voltage	VC			34	V	I _{PP} = 55A (8 x 20µs pulse)
Junction Capacitance	CJ			450	pF	VR = 0V, f = 1MHz

AU1871P6						
Parameter	Symbol	Min	Typ	Max	Unit	Test Condition
Reverse Working Voltage	VRWM			18	V	
Breakdown Voltage	VBR	19.6			V	IT = 1mA
Reverse Leakage Current	IR			0.1	µA	VRWM = 18V
Forward Voltage	VF		1.0	1.2	V	IF = 10mA
Peak Pulse Current	I _{PP}			50	A	tp = 8/20µs
Clamping Voltage	VC			26	V	I _{PP} = 10A (8 x 20µs pulse)
Clamping Voltage	VC			37.5	V	I _{PP} = 50A (8 x 20µs pulse)
Junction Capacitance	CJ			350	pF	VR = 0V, f = 1MHz

AU2471P6						
Parameter	Symbol	Min	Typ	Max	Unit	Test Condition
Reverse Working Voltage	VRWM			24	V	
Breakdown Voltage	VBR	26.7			V	IT = 1mA
Reverse Leakage Current	IR			0.1	μA	VRWM = 24V
Forward Voltage	VF			1.2	V	IF = 10mA
Peak Pulse Current	IPP			35	A	tp = 8/20μs
Clamping Voltage	VC			42	V	IPP = 10A (8 x 20μs pulse)
Clamping Voltage	VC			53.5	V	IPP = 35A (8 x 20μs pulse)
Junction Capacitance	CJ			200	pF	VR = 0V, f = 1MHz

AU3671P6						
Parameter	Symbol	Min	Typ	Max	Unit	Test Condition
Reverse Working Voltage	VRWM			36	V	
Breakdown Voltage	VBR	37			V	IT = 1mA
Reverse Leakage Current	IR			0.5	μA	VRWM = 36V
Forward Voltage	VF			1.2	V	IF = 10mA
Peak Pulse Current	IPP			25	A	tp = 8/20μs
Clamping Voltage	VC			60	V	IPP = 10A (8 x 20μs pulse)
Clamping Voltage	VC			75	V	IPP = 25A (8 x 20μs pulse)
Junction Capacitance	CJ			150	pF	VR = 0V, f = 1MHz

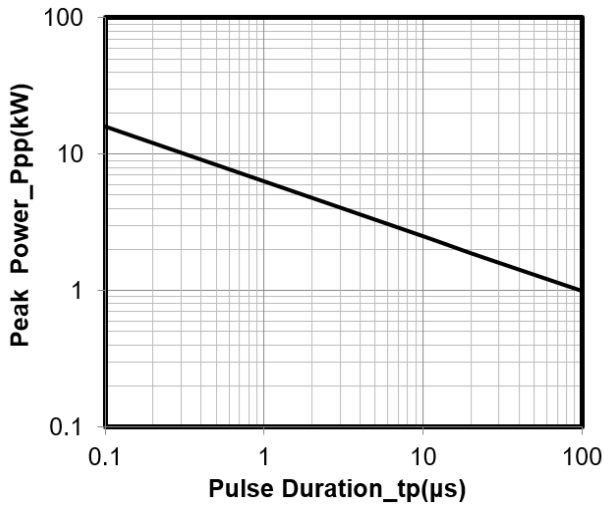

Junction Capacitance vs. Reverse Voltage

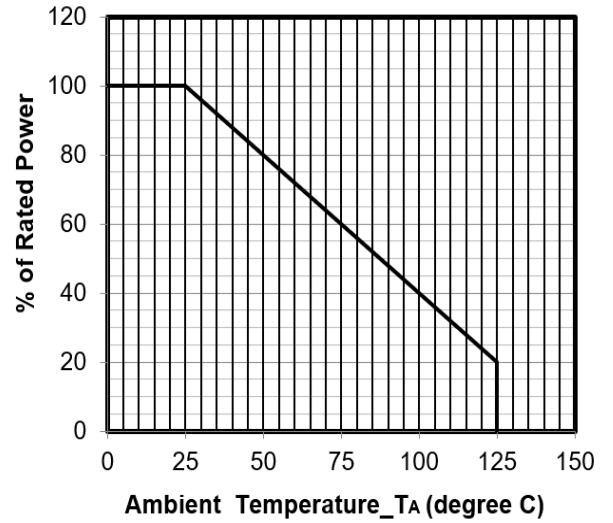

Power Derating Curve

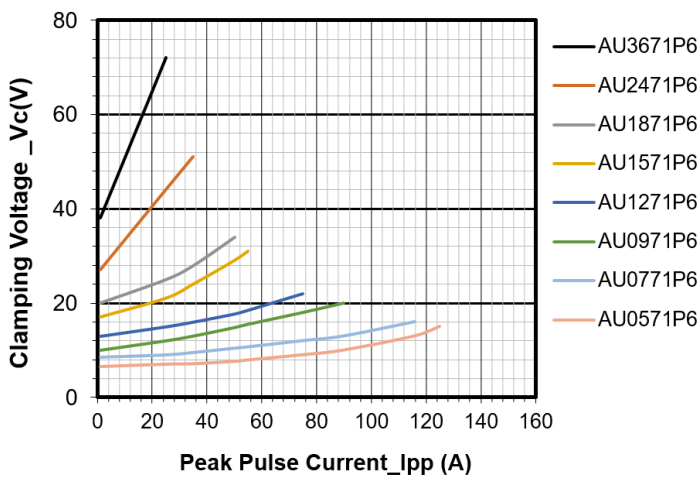

Clamping Voltage vs. Peak Pulse Current ($t_p = 8/20\mu$ s)

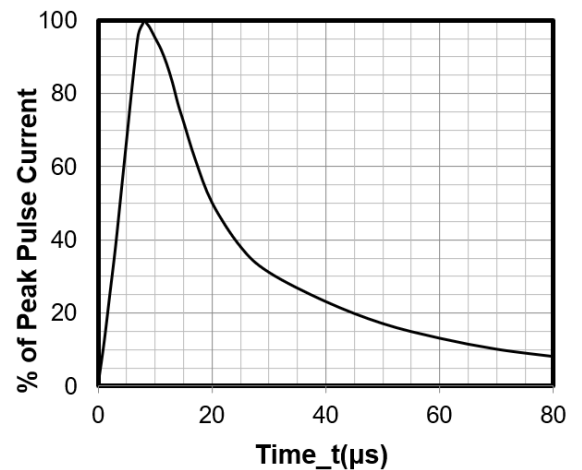

8 X 20 μ s Pulse Waveform

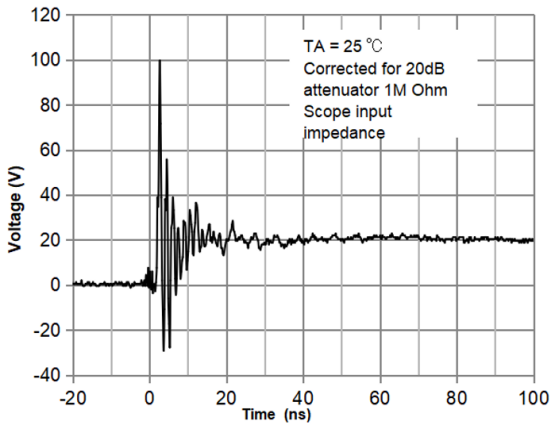

ESD Clamping Voltage(AU0571P6)
8 kV Contact per IEC61000-4-2

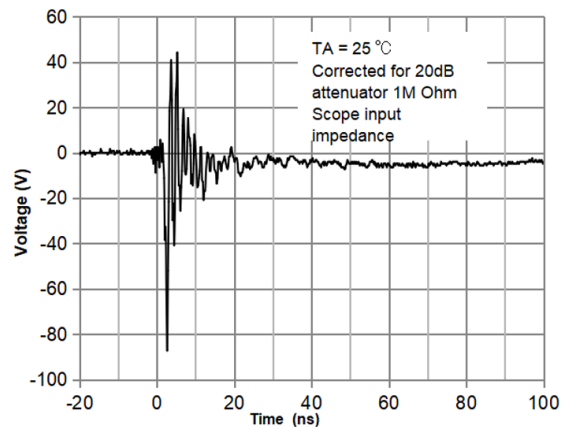

ESD Clamping Voltage(AU0571P6)
-8 kV Contact per IEC61000-4-2

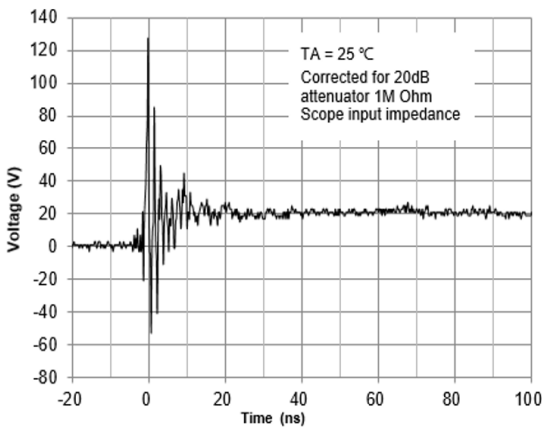

ESD Clamping Voltage(AU0771P6)
8 kV Contact per IEC61000-4-2

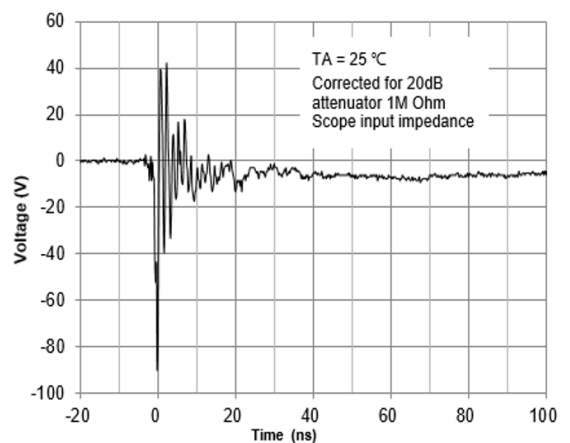

ESD Clamping Voltage(AU0771P6)
-8 kV Contact per IEC61000-4-2

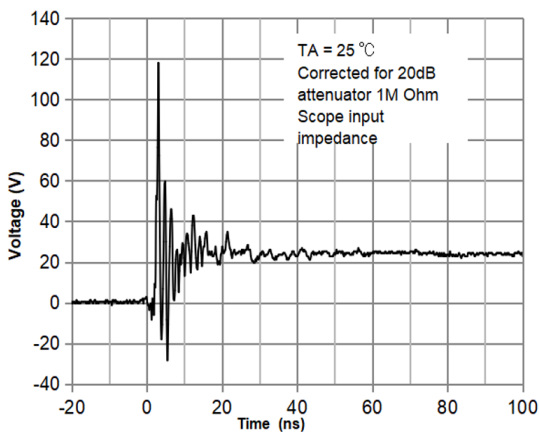

ESD Clamping Voltage(AU0971P6)
8 kV Contact per IEC61000-4-2

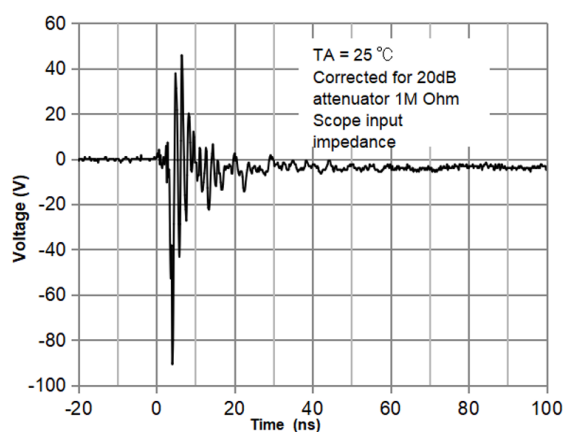

ESD Clamping Voltage(AU0971P6)
-8 kV Contact per IEC61000-4-2

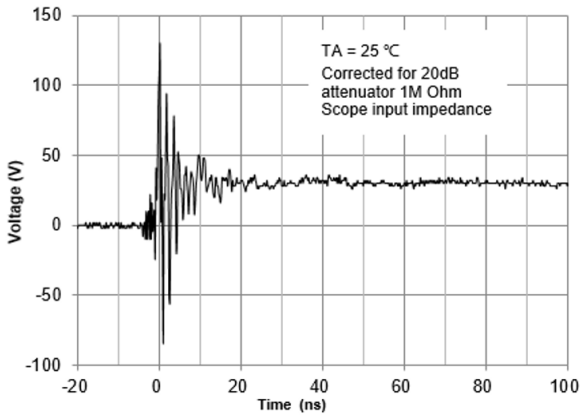

ESD Clamping Voltage(AU1271P6)
8 kV Contact per IEC61000-4-2

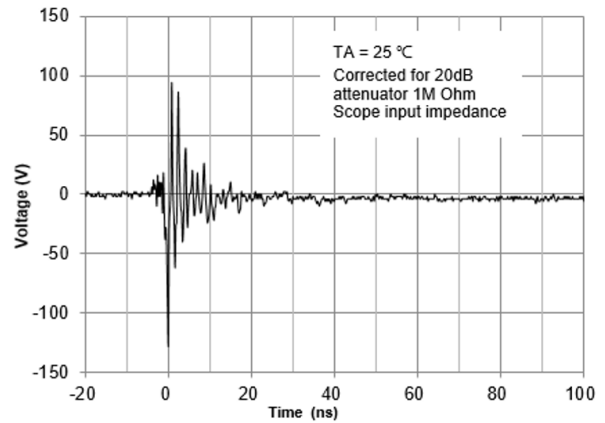

ESD Clamping Voltage(AU1271P6)
-8 kV Contact per IEC61000-4-2

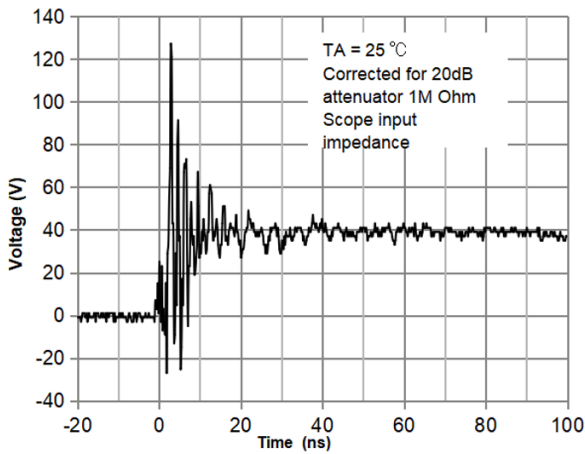

ESD Clamping Voltage(AU1571P6)
8 kV Contact per IEC61000-4-2

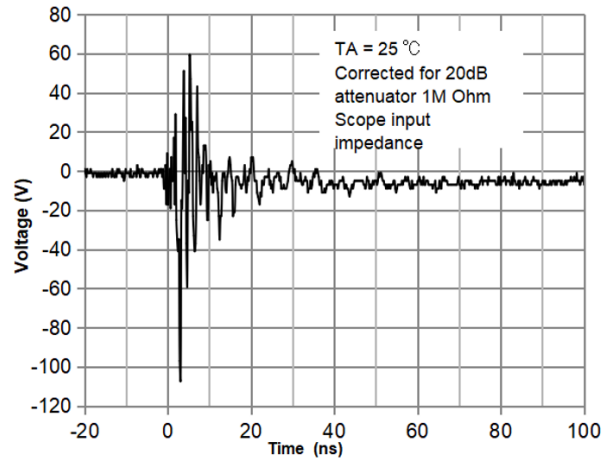

ESD Clamping Voltage(AU1571P6)
-8 kV Contact per IEC61000-4-2

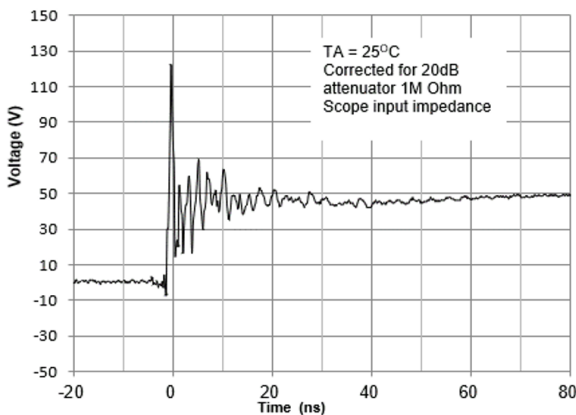

ESD Clamping Voltage(AU1871P6)
8 kV Contact per IEC61000-4-2

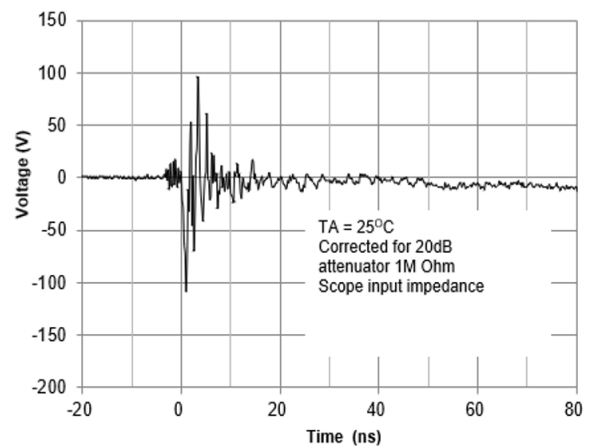

ESD Clamping Voltage(AU1871P6)
-8 kV Contact per IEC61000-4-2

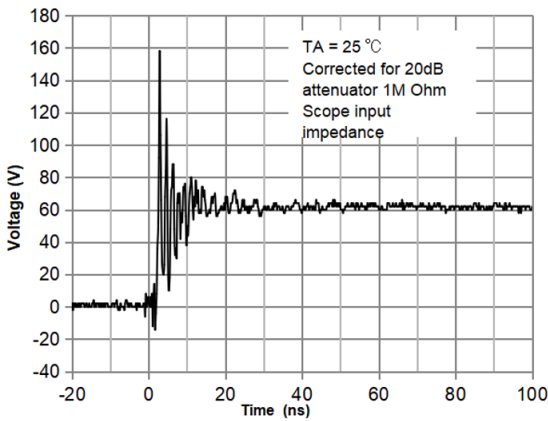

ESD Clamping Voltage(AU2471P6)
8 kV Contact per IEC61000-4-2

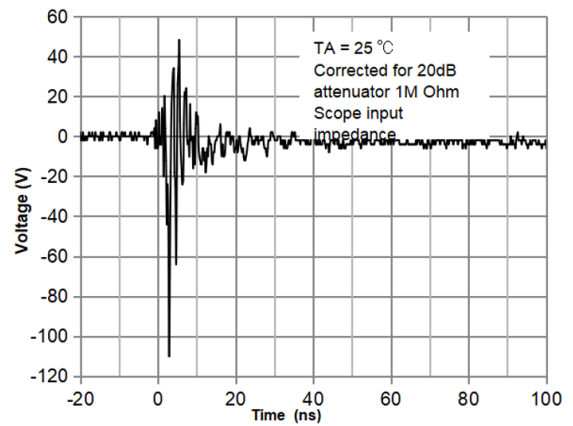

ESD Clamping Voltage(AU2471P6)
-8 kV Contact per IEC61000-4-2

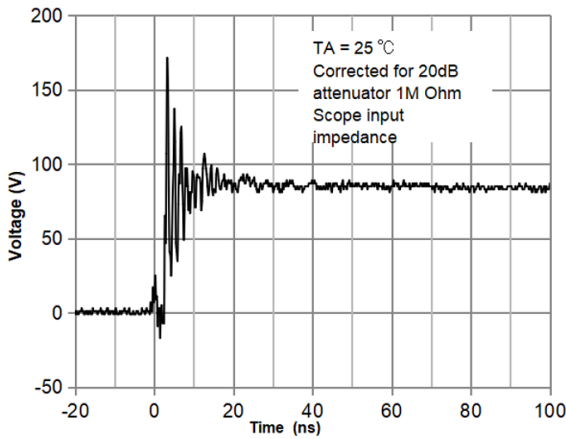

ESD Clamping Voltage(AU3671P6)
8 kV Contact per IEC61000-4-2

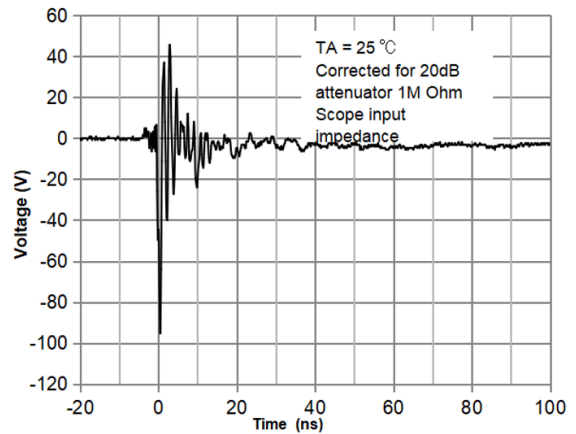

ESD Clamping Voltage(AU3671P6)
-8 kV Contact per IEC61000-4-2

DFN1610-2 Package Outline Drawing

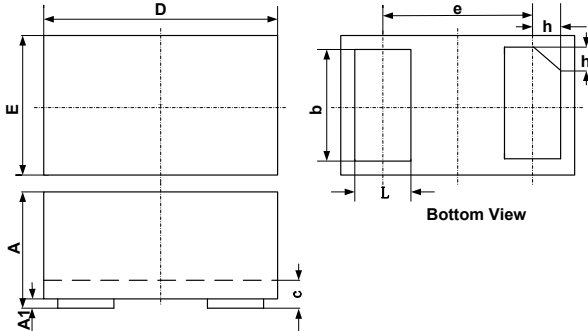

SYM	DIMENSIONS					
	MILLIMETERS			INCHES		
	MIN	NOM	MAX	MIN	NOM	MAX
A	0.45	0.50	0.55	0.018	0.020	0.022
A1	0.00	0.02	0.05	0.000	0.001	0.002
b	0.75	0.80	0.85	0.030	0.032	0.034
c	0.10	0.15	0.20	0.004	0.006	0.008
D	1.55	1.60	1.65	0.062	0.064	0.066
e	1.10 BSC			0.044 BSC		
E	0.95	1.00	1.05	0.038	0.040	0.042
L	0.35	0.40	0.45	0.014	0.016	0.018
h	0.15	0.20	0.25	0.006	0.008	0.010

Suggested Land Pattern

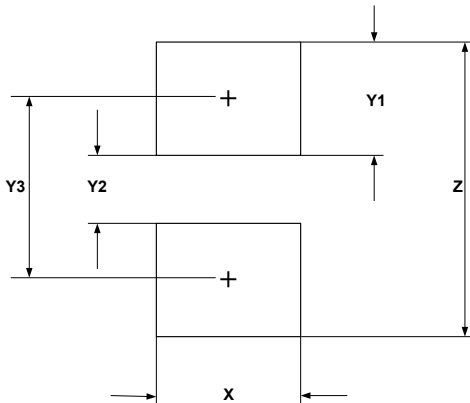

SYM	DIMENSIONS	
	MILLIMETERS	INCHES
X	1.00	0.040
Y1	0.62	0.025
Y2	0.60	0.024
Y3	1.22	0.049
Z	1.85	0.074

Contact Information

Applied Power Microelectronics Inc.
 Website: <http://www.appliedpowermicro.com>
 Email: sales@appliedpowermicro.com
 Phone: +86 (0519) 8399 3606