

### Description

The AU2521P1L is a bi-directional TVS diode, utilizing leading monolithic silicon technology to provide fast response time and low ESD clamping voltage, making this device an ideal solution for protecting voltage sensitive data and power line. The AU2521P1L complies with the IEC 61000-4-2 (ESD) with  $\pm 30\text{kV}$  air and  $\pm 30\text{kV}$  contact discharge. It is assembled into an ultra-small 1.0x0.6x0.5mm lead-free DFN package. The small size and high ESD surge protection make AU2521P1L an ideal choice to protect cell phone, digital cameras, audio players and many other portable applications.

### Features

- Protects one data or power line
- Ultra low leakage: nA level
- Operating voltage: 2.5V
- Low clamping voltage
- 2-Pin leadless package
- Complies with following standards:
  - IEC 61000-4-2 (ESD) immunity test
    - Air discharge:  $\pm 30\text{kV}$
    - Contact discharge:  $\pm 30\text{kV}$
  - IEC61000-4-5 (Lightning) 10A (8/20 $\mu\text{s}$ )
- RoHS Compliant

### Mechanical Characteristics

- Package: DFN1006-2
- Case Material: “Green” Molding Compound.
- Terminal Connections: See Diagram Below
- Marking Information: See Below

### Applications

- Cellular Handsets and Accessories
- Personal Digital Assistants
- Notebooks and Handhelds
- Portable Instrumentation
- Digital Cameras
- Peripherals
- Audio Players
- Keypads, Side Keys, LCD Displays

### Marking Information



28L = Device Marking Code

### Equivalent Circuit and Pin Configuration

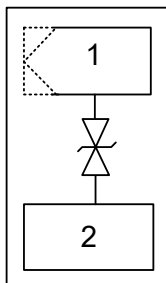

Circuit and Pin Schematic

### Ordering Information

| Part Number | Packaging         | Reel Size |
|-------------|-------------------|-----------|
| AU2521P1L   | 10000/Tape & Reel | 7 inch    |

**Absolute Maximum Ratings (T<sub>A</sub>=25°C unless otherwise specified)**

| Parameter  | Symbol | Value       | Unit |
|--|--------|-------------|------|
| Peak Pulse Power (8/20μs)                                      | Ppk    | 90          | W    |
| Peak Pulse Current (8/20μs)                                    | Ipp    | 10          | A    |
| ESD per IEC 61000-4-2 (Air)<br>ESD per IEC 61000-4-2 (Contact) | VESD   | ±30<br>±30  | kV   |
| Operating Temperature Range                                    | TJ     | -55 to +125 | °C   |
| Storage Temperature Range                                      | Tstg   | -55 to +150 | °C   |

**Electrical Characteristics (T<sub>A</sub>=25°C unless otherwise specified)**

| Parameter               | Symbol | Min | Typ | Max | Unit | Test Condition                         |
|-------------------------|--------|-----|-----|-----|------|--|
| Reverse Working Voltage | VRWM   |     | 2.5 | 2.8 | V    |  |
| Punch-Through Voltage   | VPT    | 2.9 |     |     | V    | IT = 2μA                               |
| Snap-Back Voltage       | VSB    | 2.8 |     |     | V    | IT = 50mA                              |
| Reverse Leakage Current | IR     |     |     | 0.2 | μA   | VRWM = 2.5V                            |
| Reverse Leakage Current | IR     |     |     | 0.2 | μA   | VRWM = 2.8V                            |
| Clamping Voltage        | VC     |     |     | 5   | V    | I <sub>PP</sub> = 1A (8 x 20μs pulse)  |
| Clamping Voltage        | VC     |     |     | 9   | V    | I <sub>PP</sub> = 10A (8 x 20μs pulse) |
| Junction Capacitance    | CJ     |     |     | 25  | pF   | VR = 0V, f = 1MHz                      |

**Typical Performance Characteristics (TA=25°C unless otherwise Specified)**

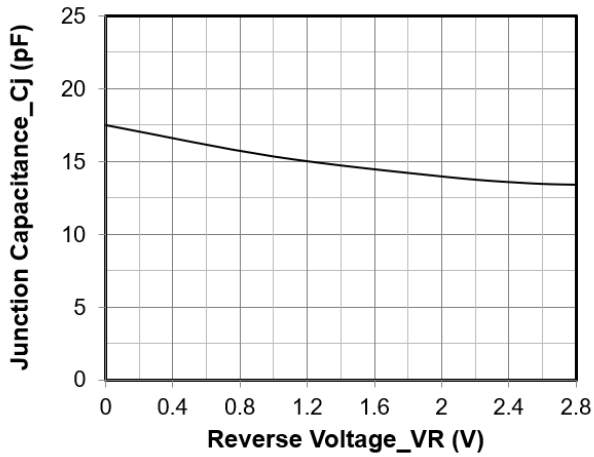

**Junction Capacitance vs. Reverse Voltage**

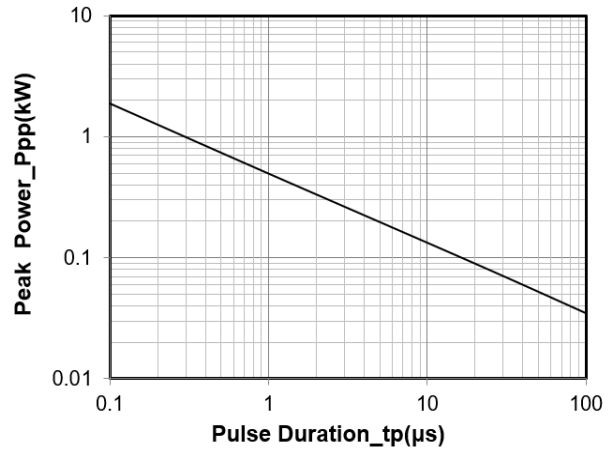

**Peak Pulse Power vs. Pulse Time**

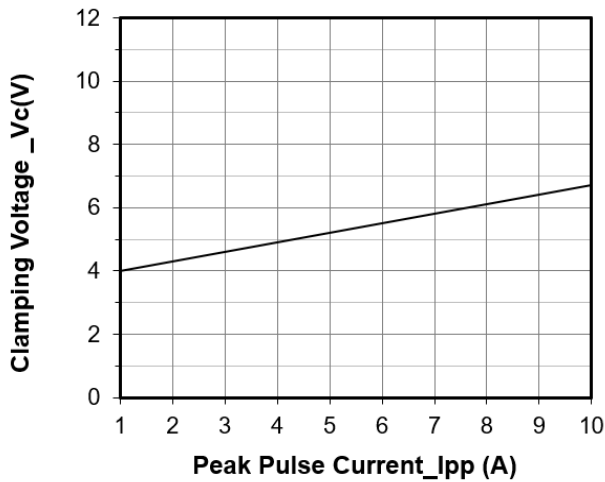

**Clamping Voltage vs. Peak Pulse Current (tp = 8/20μs)**

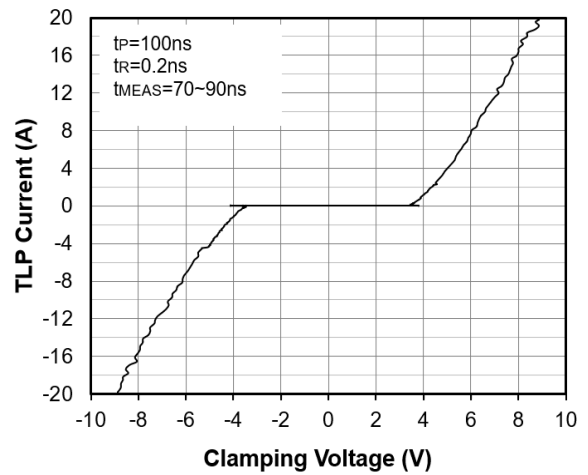

**TLP Measurement**

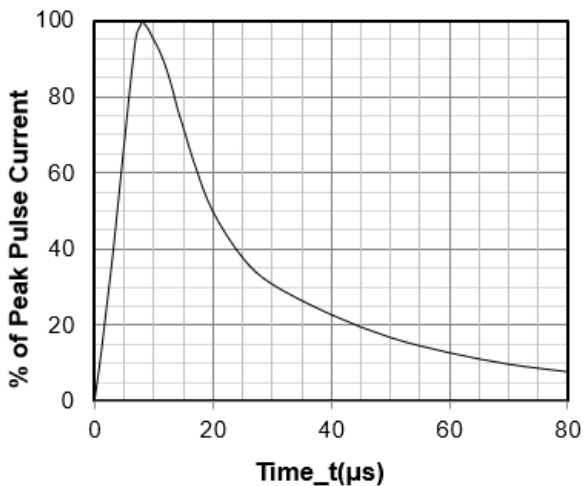

**8 X 20μs Pulse Waveform**

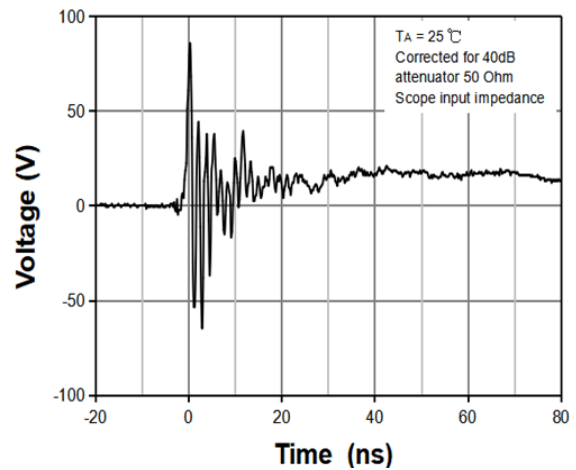

**ESD Clamping Voltage**  
**8 kV Contact per IEC61000-4-2**

### DFN1006-2 Package Outline Drawing

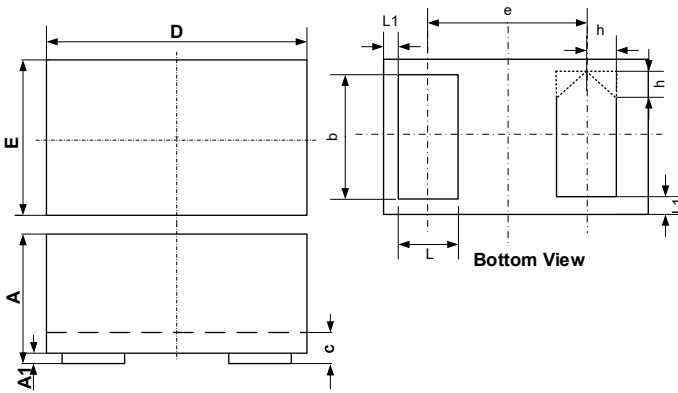

| SYM | DIMENSIONS  |      |      |           |       |       |
|-----|-------------|------|------|-----------|-------|-------|
|     | MILLIMETERS |      |      | INCHES    |       |       |
|     | MIN         | NOM  | MAX  | MIN       | NOM   | MAX   |
| A   | 0.40        | -    | 0.55 | 0.016     | -     | 0.022 |
| A1  | 0.00        | 0.02 | 0.05 | 0.000     | 0.001 | 0.002 |
| b   | 0.45        | 0.50 | 0.55 | 0.018     | 0.020 | 0.022 |
| c   | 0.12        | 0.15 | 0.18 | 0.005     | 0.006 | 0.007 |
| D   | 0.95        | 1.00 | 1.05 | 0.037     | 0.039 | 0.041 |
| e   | 0.65 BSC    |      |      | 0.026 BSC |       |       |
| E   | 0.55        | 0.60 | 0.65 | 0.022     | 0.024 | 0.026 |
| L   | 0.20        | 0.25 | 0.30 | 0.008     | 0.010 | 0.012 |
| L1  | 0.05REF     |      |      | 0.002REF  |       |       |
| h   | 0.07        | 0.12 | 0.17 | 0.003     | 0.005 | 0.007 |

### Suggested Land Pattern

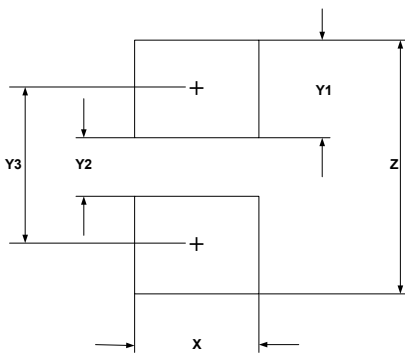

| SYM | DIMENSIONS  |        |
|-----|-------------|--------|
|     | MILLIMETERS | INCHES |
| X   | 0.60        | 0.024  |
| Y1  | 0.50        | 0.020  |
| Y2  | 0.30        | 0.012  |
| Y3  | 0.80        | 0.032  |
| Z   | 1.30        | 0.052  |

### Contact Information

Applied Power Microelectronics Inc.  
 Website: <http://www.appliedpowermicro.com>  
 Email: [sales@appliedpowermicro.com](mailto:sales@appliedpowermicro.com)  
 Phone: +86 (0519) 8399 3606