

Description

The AU2421P0LV is a 24V bi-directional TVS diode, utilizing leading monolithic silicon technology to provide fast response time and low ESD clamping voltage, making this device an ideal solution for protecting voltage sensitive data and power line. The AU2421P0LV complies with the IEC 61000-4-2 (ESD) with ± 30 kV air and ± 30 kV contact discharge. It is assembled into an ultra-small lead-free DFN0603-2 package. The small size and high ESD surge protection make AU2421P0LV an ideal choice to protect cell phone, digital cameras, audio players and many other portable applications.

Features

- Protects one data or power line
- Ultra low leakage: nA level
- Operating voltage: 24V
- Low clamping voltage
- Complies with following standards:
 - IEC 61000-4-2 (ESD) immunity test
 - Air discharge: ± 30 kV
 - Contact discharge: ± 30 kV
 - IEC61000-4-5 (Lightning) 5A (8/20 μ s)
- RoHS Compliant

Mechanical Characteristics

- Package: DFN0603-2
- Case Material: “Green” Molding Compound.
- Terminal Connections: See Diagram Below
- Marking Information: See Below

Applications

- Cellular Handsets and Accessories
- Personal Digital Assistants
- Notebooks and Handhelds
- Portable Instrumentation
- Digital Cameras
- Peripherals
- Audio Players

Marking Information



CL = Device Marking Code

Dimensions and Pin Configuration

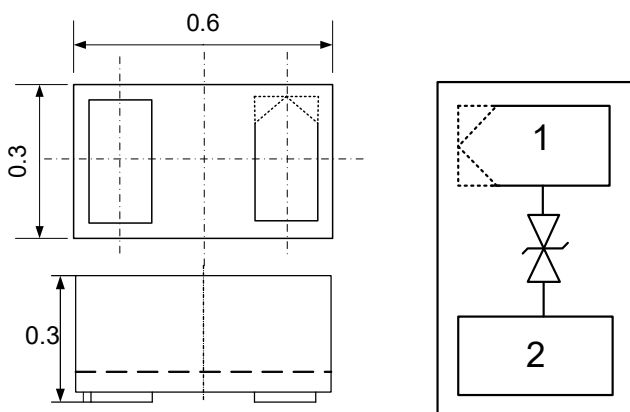

Package Dimensions

Circuit and Pin Schematic

Ordering Information

Part Number	Packaging	Reel Size
AU2421P0LV	10000/Tape & Reel	7 inch

Absolute Maximum Ratings (T_A=25°C unless otherwise specified)

Parameter	Symbol	Value	Unit
Peak Pulse Power (8/20μs)	Ppk	180	W
Peak Pulse Current (8/20μs)	Ipp	5	A
ESD per IEC 61000-4-2 (Air) ESD per IEC 61000-4-2 (Contact)	VESD	±30 ±30	kV
Operating Temperature Range	TJ	-55 to +125	°C
Storage Temperature Range	Tstg	-55 to +150	°C

Electrical Characteristics (T_A=25°C unless otherwise specified)

Parameter	Symbol	Min	Typ	Max	Unit	Test Condition
Reverse Working Voltage	VRWM			24	V	
Breakdown Voltage	VBR	27			V	IT = 1mA
Reverse Leakage Current	IR			0.2	μA	VRWM = 24V
Clamping Voltage	VC			32	V	I _{PP} = 1A (8 x 20μs pulse)
Clamping Voltage	VC			36	V	I _{PP} = 5A (8 x 20μs pulse)
Junction Capacitance	CJ		5		pF	VR = 0V, f = 1MHz

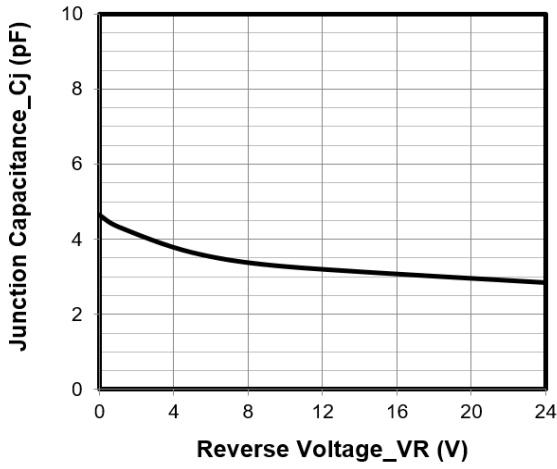
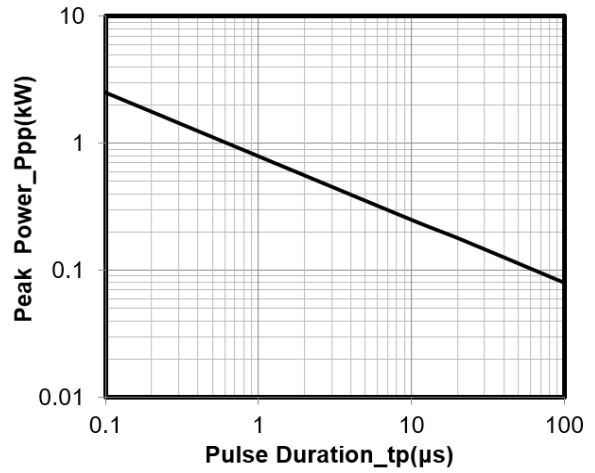
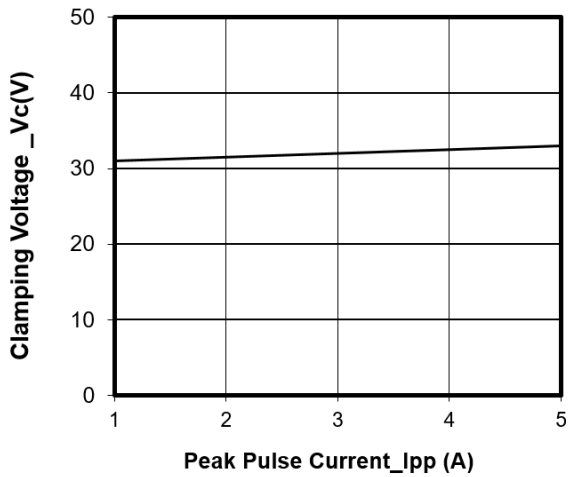
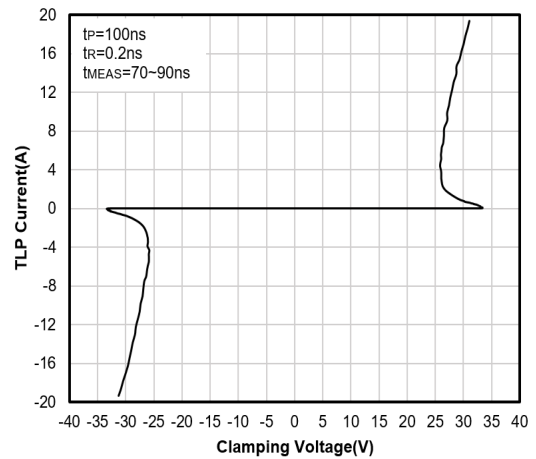
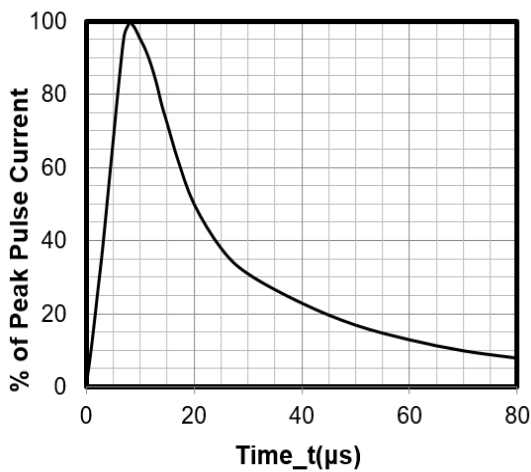
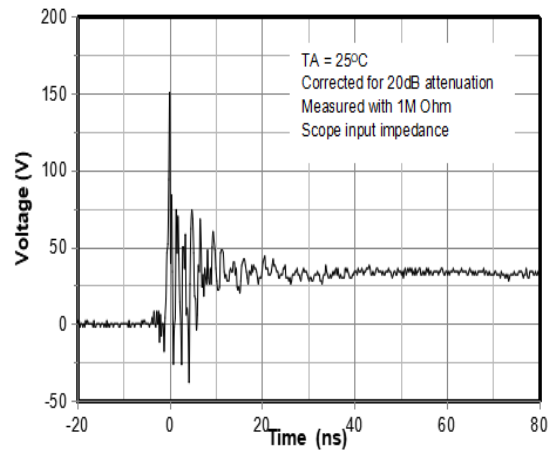
Typical Performance Characteristics (TA=25°C unless otherwise Specified)

Junction Capacitance vs. Reverse Voltage

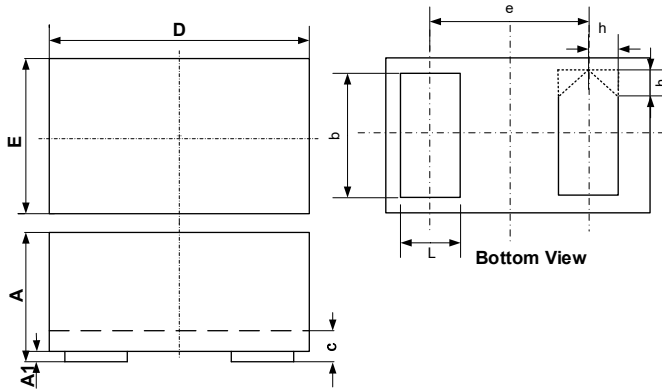
Peak Pulse Power vs. Pulse Time

Clamping Voltage vs. Peak Pulse Current

TLP Curve

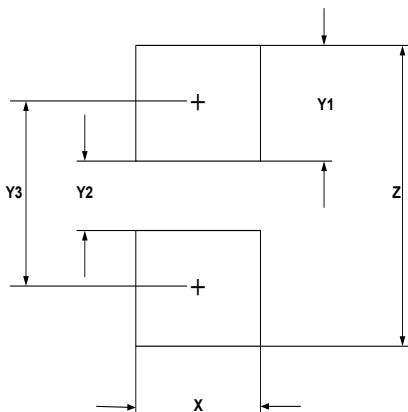
8 X 20μs Pulse Waveform

ESD Clamping Voltage
8 kV Contact per IEC61000-4-2

DFN0603-2 Package Outline Drawing



SYM	DIMENSIONS		
	MILLIMETERS		
	MIN	NOM	MAX
A	0.230		0.330
A1	0.000	0.020	0.050
b	0.215	0.245	0.275
c	0.120	0.150	0.180
D	0.550	0.600	0.650
e	0.355 BSC		
E	0.250	0.300	0.350
L	0.160	0.190	0.220
h	0.079 BSC		

Suggested Land Pattern



SYM	DIMENSIONS	
	MILLIMETERS	INCHES
X	0.30	0.012
Y1	0.25	0.010
Y2	0.15	0.006
Y3	0.40	0.016
Z	0.65	0.026

Contact Information

Applied Power Microelectronics Inc.

Website: <http://www.appliedpowermicro.com>

Email: sales@appliedpowermicro.com

Phone: +86 (0519) 8399 3606