

Description

The AU2401P4-3D is a high power TVS, utilizing leading monolithic silicon technology to provide fast response time and low ESD clamping voltage, making this device an ideal solution for protecting voltage sensitive lines. The AU2401P4-3D complies with the IEC 61000-4-2 (ESD) with $\pm 30\text{kV}$ air and $\pm 30\text{kV}$ contact discharge. It is assembled into a 3-pin DFN2020-3 lead-free package. Each device will protect one line. The combination of small size, and high surge capability makes them ideal for use in applications such as cellular phones, LCD displays, USB, and multi media card interfaces.

Features

- Low leakage: nA level
- Low operating voltage: 24V
- Ultra low clamping voltage
- One power line protects
- Complies with following standards:
 - IEC 61000-4-2 (ESD) immunity test
 - Air discharge: $\pm 30\text{kV}$
 - Contact discharge: $\pm 30\text{kV}$
 - IEC61000-4-5 (Lightning) 140A (8/20 μs)
- RoHS Compliant

Mechanical Characteristics

- Package: DFN2020-3
- Case Material: “Green” Molding Compound
- Terminal Connections: See Diagram Below
- Marking Information: See Below

Applications

- Power Management
- Industrial Application
- Power Supply Protection

Marking Information

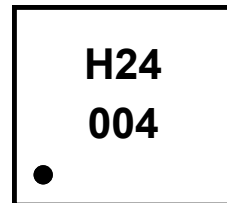

Equivalent Circuit and Pin Configuration

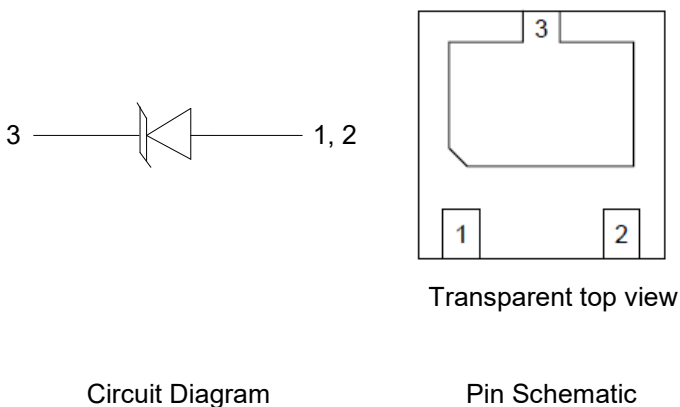

Ordering Information

| Part Number | Packaging | Reel Size |
|-------------|------------------|-----------|
| AU2401P4-3D | 3000/Tape & Reel | 7 inch |

Absolute Maximum Ratings ($T_A=25^{\circ}\text{C}$ unless otherwise specified)

| Parameter | Symbol | Value | Unit |
|--|------------------|----------------------|--------------------|
| Peak Pulse Power (8/20 μs) | Ppk | 6440 | W |
| Peak Pulse Current (8/20 μs) | I _{PP} | 140 | A |
| ESD per IEC 61000-4-2 (Air) ESD per IEC 61000-4-2 (Contact) | V _{ESD} | ± 30 ± 30 | kV |
| Operating Temperature Range | T _J | -55 to +125 | $^{\circ}\text{C}$ |
| Storage Temperature Range | T _{stg} | -55 to +150 | $^{\circ}\text{C}$ |

Electrical Characteristics ($T_A=25^{\circ}\text{C}$ unless otherwise specified)

| Parameter | Symbol | Min | Typ | Max | Unit | Test Condition |
|-------------------------|------------------|------|-----|-----|---------------|---|
| Reverse Working Voltage | V _{RWM} | | 24 | | V | |
| Breakdown Voltage | V _{BR} | 24.8 | | | V | I _T = 1mA |
| Reverse Leakage Current | I _R | | | 1.0 | μA | V _{RWM} = 24V |
| Clamping Voltage | V _C | | | 35 | V | I _{PP} = 50A (8 x 20 μs pulse) |
| Clamping Voltage | V _C | | | 46 | V | I _{PP} = 140A (8 x 20 μs pulse) |
| Junction Capacitance | C _J | | 380 | | pF | V _R = 0V, f = 1MHz |

Typical Performance Characteristics ($T_A=25^\circ\text{C}$ unless otherwise Specified)

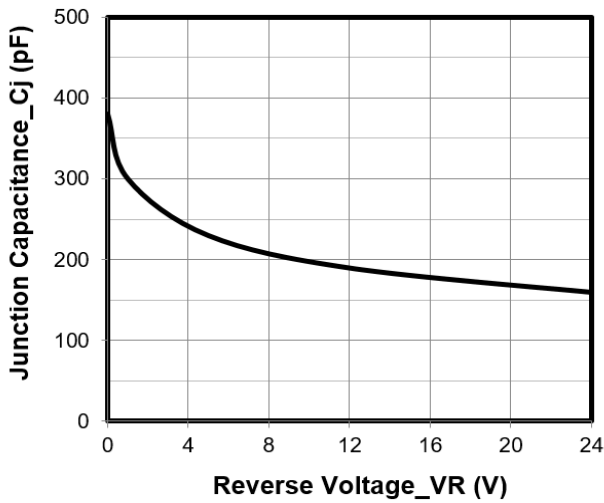

Junction Capacitance vs. Reverse Voltage

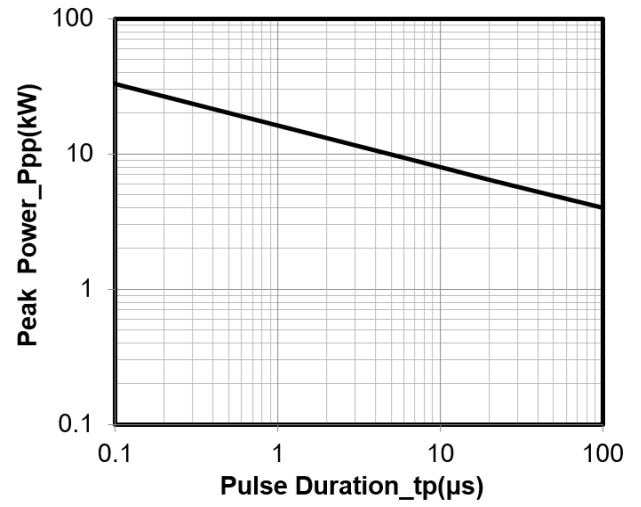

Peak Pulse Power vs. Pulse Time

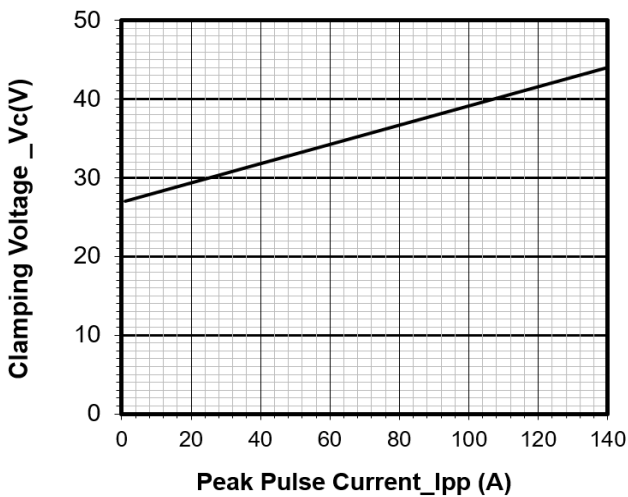

Clamping Voltage vs. Peak Pulse Current

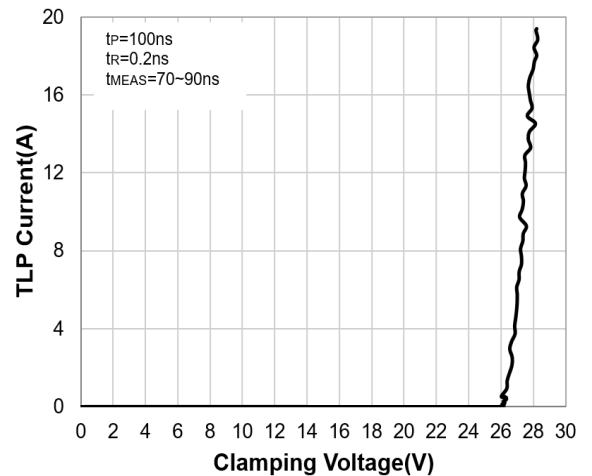

TLP Curve

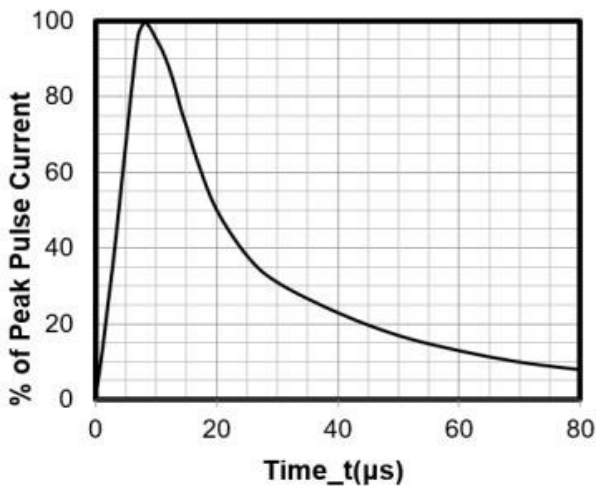

8 X 20μs Pulse Waveform

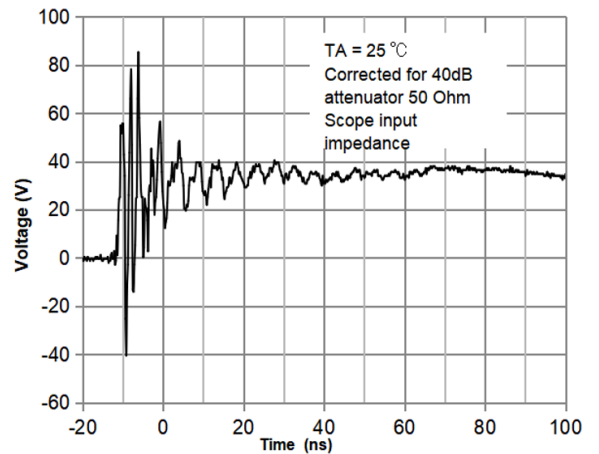

ESD Clamping Voltage

8 kV Contact per IEC61000-4-2

DFN2020-3 Package Outline Drawing

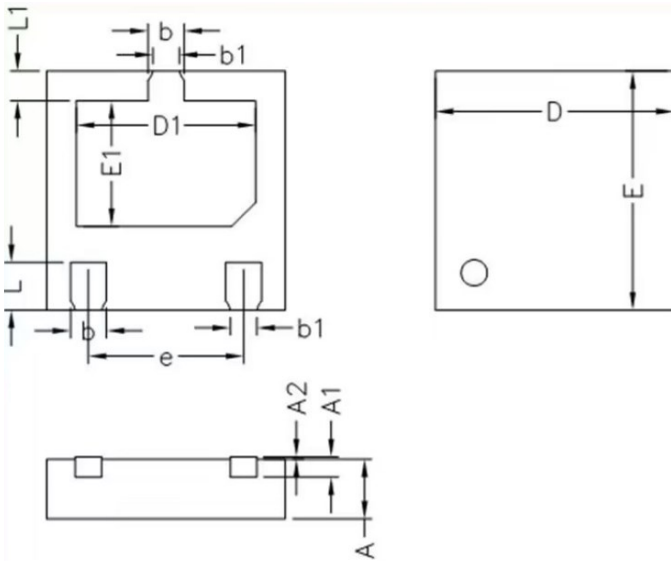

| SYM | MILLIMETERS | | |
|-----|-------------|------|------|
| | MIN | NOM | MAX |
| D | 1.95 | 2.00 | 2.05 |
| E | 1.95 | 2.00 | 2.05 |
| D1 | 1.45 | 1.50 | 1.55 |
| E1 | 1.00 | 1.05 | 1.10 |
| L1 | 0.20 | 0.25 | 0.30 |
| L | 0.35 | 0.40 | 0.45 |
| b1 | 0.22REF | | |
| b | 0.25 | 0.30 | 0.35 |
| e | 1.30BSC | | |
| A1 | 0.15REF | | |
| A2 | 0.00 | 0.02 | 0.05 |
| A | 0.45 | 0.50 | 0.55 |

Suggested Land Pattern

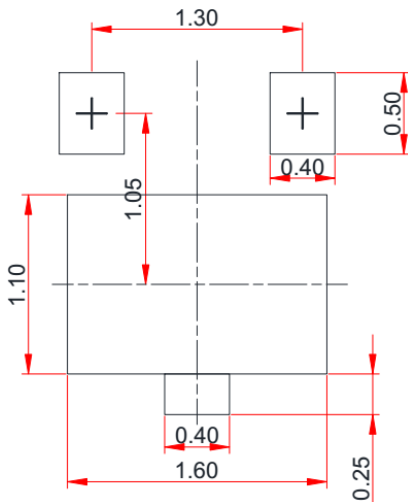

Unit: mm

Contact Information

Applied Power Microelectronics Inc.

Website: <http://www.appliedpowermicro.com>

Email: sales@appliedpowermicro.com

Phone: +86 (0519) 8399 3606