

Description

The AU1881D1F-T is a bi-directional TVS diode, utilizing leading monolithic silicon technology to provide fast response time and low ESD clamping voltage, making this device an ideal solution for protecting voltage sensitive data and power lines. The AU1881D1F-T complies with the IEC 61000-4-2 (ESD) with $\pm 30\text{kV}$ air and $\pm 30\text{kV}$ contact discharge. It is assembled into a SOD-123FL lead-free package. The small size and high ESD/surge protection make AU1881D1F-T an ideal choice to protect cell phone, digital cameras, audio players and many other portable applications.

Features

- Protects one data or power line
- Ultra low leakage: nA level
- Operating voltage: 18V
- Ultra low clamping voltage
- Complies with following standards:
 - IEC 61000-4-2 (ESD) immunity test
 - Air discharge: $\pm 30\text{kV}$
 - Contact discharge: $\pm 30\text{kV}$
 - IEC61000-4-5 (Lightning) 300A (8/20 μs)
- RoHS Compliant

Pin Configuration

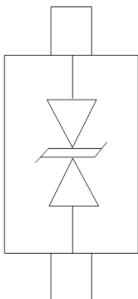

Circuit and Pin Schematic

Mechanical Characteristics

- Package: SOD-123FL
- Lead Finish: Matte Tin
- Case Material: "Green" Molding Compound.
- Terminal Connections: See Diagram Below
- Marking Information: See Below

Applications

- Fast-charge battery chargers
- Power management system
- Cellular Handsets and Accessories
- Personal Digital Assistants
- Notebooks and Handhelds
- Portable Instrumentation
- Digital Cameras
- Peripherals

Marking Information

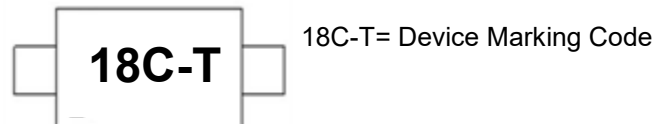

Ordering Information

Part Number	Packaging	Reel Size
AU1881D1F-T	3000/Tape & Reel	7 inch

Absolute Maximum Ratings ($T_A=25^{\circ}\text{C}$ unless otherwise specified)

Parameter	Symbol	Value	Unit
Peak Pulse Power (8/20 μs)	Ppk	12000	W
Peak Pulse Current (8/20 μs)	Ipp	300	A
ESD per IEC 61000-4-2 (Air)	VESD	± 30	kV
ESD per IEC 61000-4-2 (Contact)		± 30	
Operating Temperature Range	TJ	-55 to +125	$^{\circ}\text{C}$
Storage Temperature Range	Tstg	-55 to +150	$^{\circ}\text{C}$

Electrical Characteristics ($T_A=25^{\circ}\text{C}$ unless otherwise specified)

Parameter	Symbol	Min	Typ	Max	Unit	Test Condition
Reverse Working Voltage	VRWM			18	V	
Breakdown Voltage	VBR	19			V	IT = 1mA
Reverse Leakage Current	IR			1.0	μA	VRWM = 18V
Forward Voltage	VF			1.2	V	IF = 10mA
Clamping Voltage	VC			24	V	I _{PP} = 1A (8 x 20 μs pulse)
Clamping Voltage	VC			40	V	I _{PP} = 300A (8 x 20 μs pulse)
Junction Capacitance	CJ		260		pF	VR = 0V, f = 1MHz

Typical Performance Characteristics (T_A=25°C unless otherwise Specified)

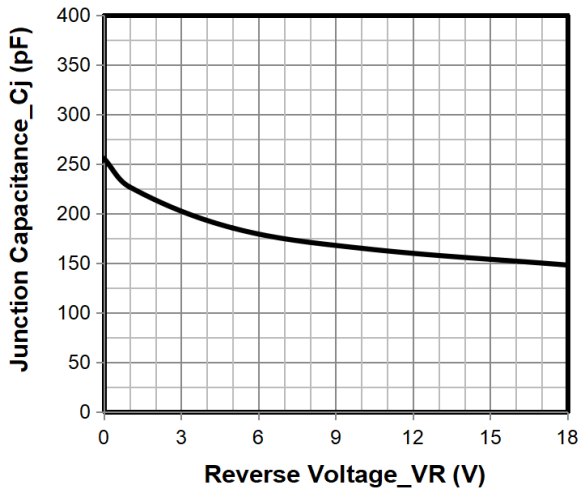

Junction Capacitance vs. Reverse Voltage

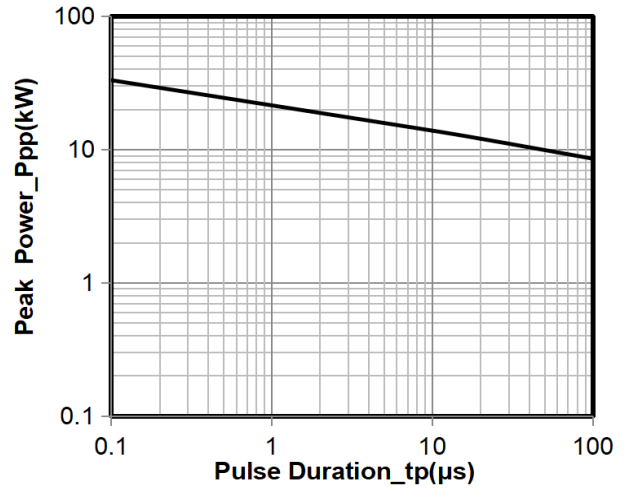

Peak Pulse Power vs. Pulse Time

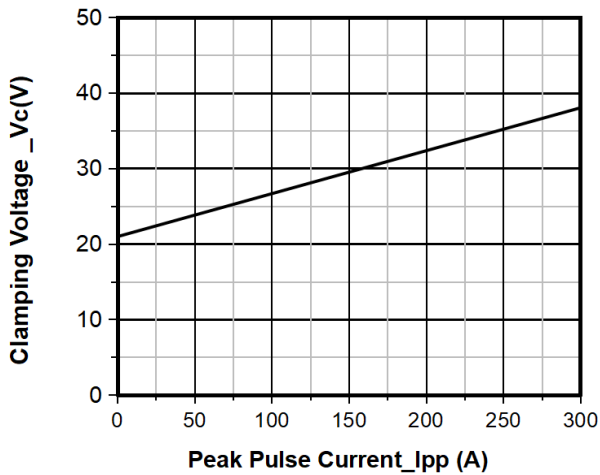

Clamping Voltage vs. Peak Pulse Current

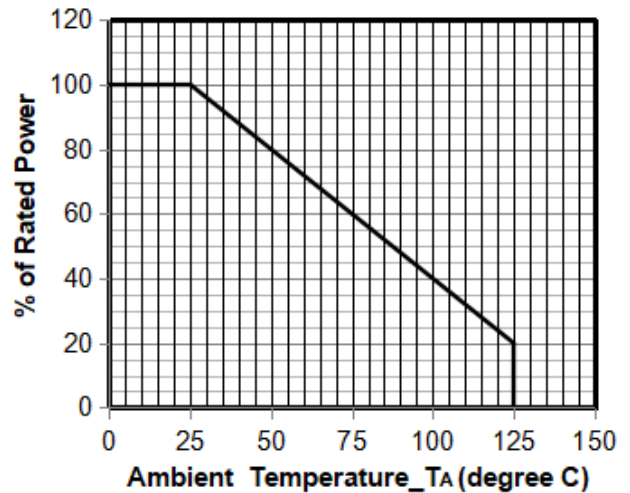

Power Derating Curve

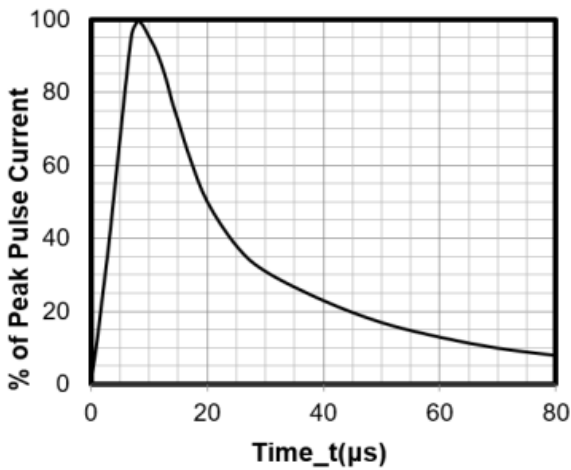

8 X 20μs Pulse Waveform

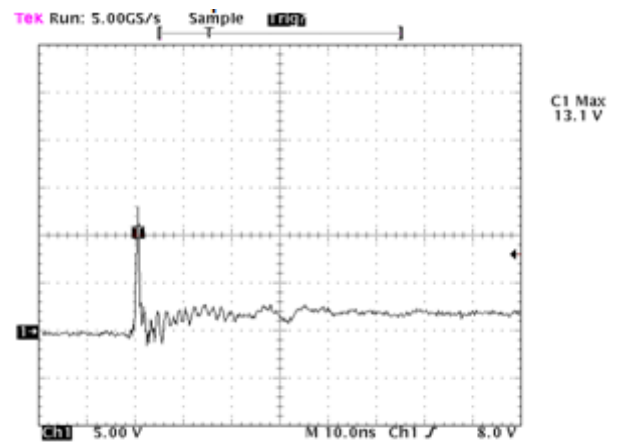

**Note: Data is taken with a 10x attenuator
ESD Clamping Voltage**

8 kV Contact per IEC61000-4-2

SOD-123FL Package Outline Drawing

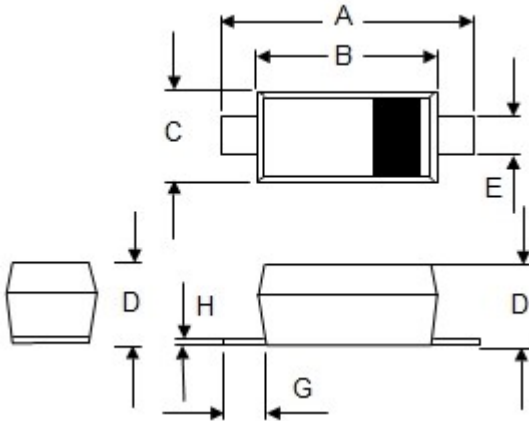

SYM	DIMENSIONS			
	MILLIMETERS		INCHES	
	MIN	MAX	MIN	MAX
A	3.40	3.95	0.142	0.155
B	2.50	2.90	0.098	0.114
C	1.40	1.95	0.055	0.077
D	0.80	1.00	0.031	0.040
E	0.50	1.10	0.020	0.043
G	0.25	—	0.010	—
H	—	0.20	—	0.008

Suggested Land Pattern

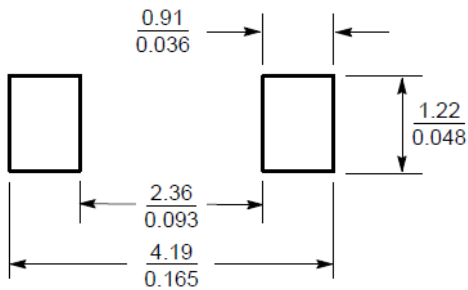

SCALE 10:1 ($\frac{\text{mm}}{\text{inches}}$)

Contact Information

Applied Power Microelectronics Inc.

Website: <http://www.appliedpowermicro.com>

Email: sales@appliedpowermicro.com

Phone: +86 (0519) 8399 3606