

Description

The AU1531D3 is an Uni-directional TVS diode, utilizing leading monolithic silicon technology to provide fast response time and low ESD clamping voltage, making this device an ideal solution for protecting voltage sensitive data and power line. The AU1531D3 complies with the IEC 61000-4-2 (ESD) with $\pm 30\text{kV}$ air and $\pm 30\text{kV}$ contact discharge. It is assembled into an ultra-small lead-free DFN package. The small size and high ESD surge protection make AU1531D3 an ideal choice to protect cell phone, digital cameras, audio players and many other portable applications.

Features

- Protects one data or power line
- Ultra low leakage: nA level
- Operating voltage: 15V
- Low clamping voltage
- 2-pin leadless package
- Complies with following standards:
 - IEC 61000-4-2 (ESD) immunity test
 - Air discharge: $\pm 30\text{kV}$
 - Contact discharge: $\pm 30\text{kV}$
 - IEC61000-4-5 (Lightning) 30A (8/20 μs)
- RoHS Compliant

Mechanical Characteristics

- Package: SOD-323
- Case Material: “Green” Molding Compound.
- Terminal Connections: See Diagram Below
- Marking Information: See Below

Applications

- Cellular Handsets and Accessories
- Personal Digital Assistants
- Notebooks and Handhelds
- Portable Instrumentation
- Power Supply
- Keypads, Side Keys, LCD Displays

Marking Information

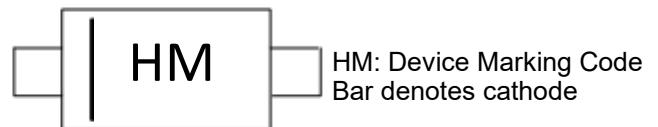

Dimensions and Pin Configuration

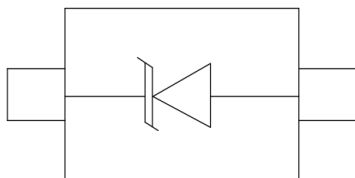

Circuit and Pin Schematic

Ordering Information

| Part Number | Packaging | Reel Size |
|-------------|------------------|-----------|
| AU1531D3 | 3000/Tape & Reel | 7 inch |

Absolute Maximum Ratings ($T_A=25^{\circ}\text{C}$ unless otherwise specified)

| Parameter | Symbol | Value | Unit |
|--|--------|-------------|--------------------|
| Peak Pulse Power (8/20 μs) | Ppk | 900 | W |
| Peak Pulse Current (8/20 μs) | Ipp | 30 | A |
| ESD per IEC 61000-4-2 (Air) | VESD | ± 30 | kV |
| ESD per IEC 61000-4-2 (Contact) | | ± 30 | |
| Operating Temperature Range | TJ | -55 to +125 | $^{\circ}\text{C}$ |
| Storage Temperature Range | Tstg | -55 to +150 | $^{\circ}\text{C}$ |

Electrical Characteristics ($T_A=25^{\circ}\text{C}$ unless otherwise specified)

| Parameter | Symbol | Min | Typ | Max | Unit | Test Condition |
|-------------------------|--------|-----|-----|-----|---------------|--|
| Reverse Working Voltage | VRWM | | | 15 | V | Pin 1 to Pin 2 |
| Breakdown Voltage | VBR | 16 | | | V | IT = 1mA, Pin 1 to Pin 2 |
| Reverse Leakage Current | IR | | | 0.5 | μA | VRWM = 15V, Pin 1 to Pin 2 |
| Forward Voltage | VF | | | 1.2 | V | IF = 10mA, Pin 2 to Pin 1 |
| Clamping Voltage | VC | | | 20 | V | IPP = 1A (8 x 20 μs pulse), Pin 1 to Pin 2 |
| Clamping Voltage | VC | | | 30 | V | IPP = 30A (8 x 20 μs pulse), Pin 1 to Pin 2 |
| Junction Capacitance | CJ | | 150 | | pF | VR = 0V, f = 1MHz |

Typical Performance Characteristics ($T_A=25^\circ\text{C}$ unless otherwise Specified)

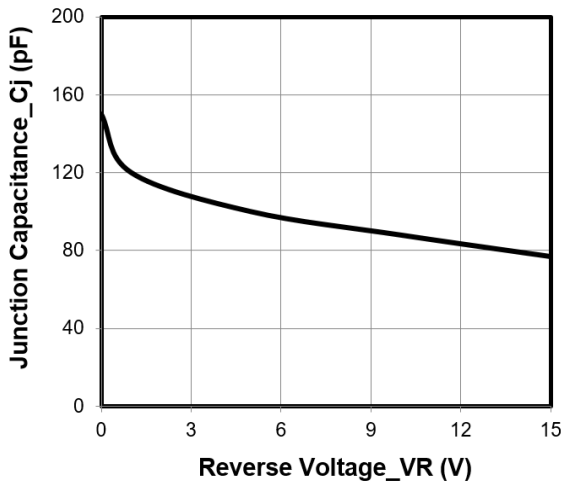

Junction Capacitance vs. Reverse Voltage

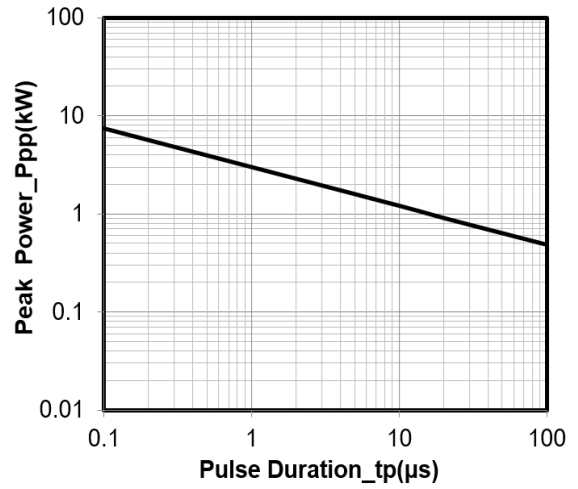

Peak Pulse Power vs. Pulse Time

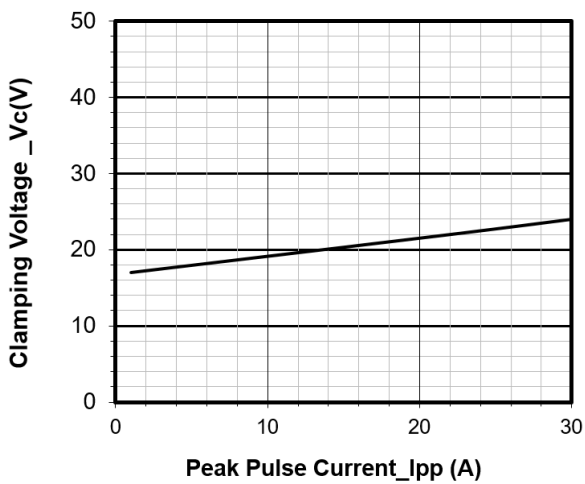

Clamping Voltage vs. Peak Pulse Current

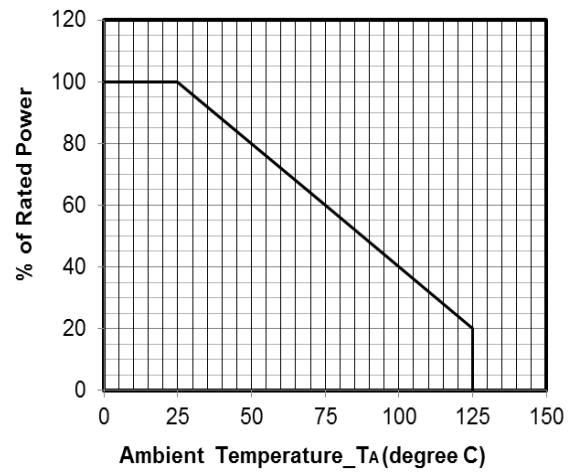

Power Derating Curve

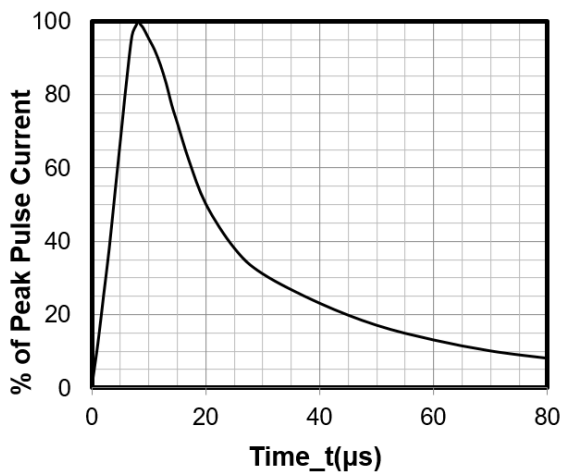

8 X 20μs Pulse Waveform

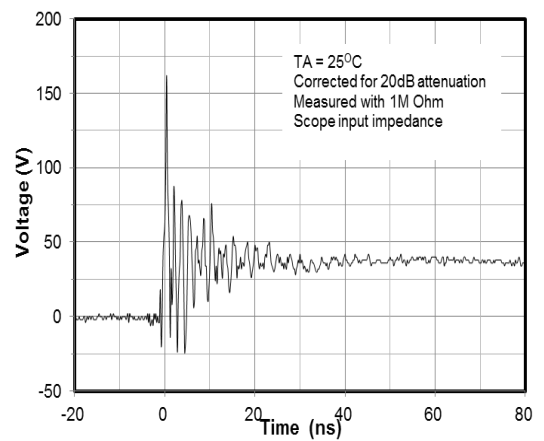

**ESD Clamping Voltage
8 kV Contact per IEC61000-4-2**

SOD-323 Package Outline Drawing

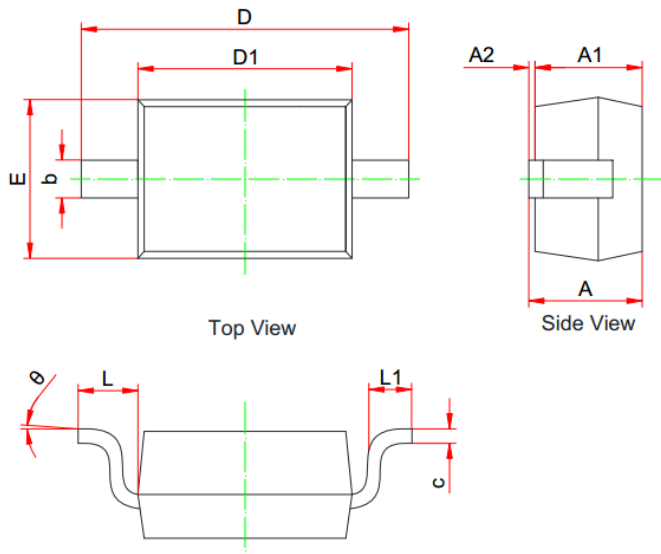

| SYM | MILLIMETERS | | |
|-----|-------------|-------|-------|
| | MIN | NOM | MAX |
| A | 0.800 | -- | 1.100 |
| A1 | 0.800 | -- | 0.900 |
| A2 | 0.000 | -- | 0.100 |
| b | 0.250 | -- | 0.400 |
| c | 0.080 | -- | 0.177 |
| D1 | 1.600 | 1.700 | 1.800 |
| D | 2.300 | -- | 2.800 |
| E | 1.150 | -- | 1.400 |
| L | 0.475REF | | |
| L1 | 0.100 | -- | 0.500 |
| Θ | 0° | -- | 8° |

Suggested Land Pattern



Unit: mm

Contact Information

Applied Power Microelectronics Inc.

Website: <http://www.appliedpowermicro.com>

Email: sales@appliedpowermicro.com

Phone: +86 (0519) 8399 3606