

### Description

The AU1211P1 is a 12V bi-directional TVS diode, utilizing leading monolithic silicon technology to provide fast response time and low ESD clamping voltage, making this device an ideal solution for protecting voltage sensitive data and power line. The AU1211P1 complies with the IEC 61000-4-2 (ESD) with  $\pm 30$  kV air and  $\pm 30$  kV contact discharge. It is assembled into an ultra-small lead-free DFN1006-2 package. The small size and high ESD surge protection make AU1211P1 an ideal choice to protect cell phone, digital cameras, audio players and many other portable applications.

### Features

- Protects one data or power line
- Ultra low leakage: nA level
- Operating voltage: 12V
- Low clamping voltage
- Complies with following standards:
  - IEC 61000-4-2 (ESD) immunity test
    - Air discharge:  $\pm 30$  kV
    - Contact discharge:  $\pm 30$  kV
  - IEC61000-4-5 (Lightning) 15A (8/20 $\mu$ s)
- RoHS Compliant

### Mechanical Characteristics

- Package: DFN1006-2
- Case Material: “Green” Molding Compound.
- Terminal Connections: See Diagram Below
- Marking Information: See Below

### Applications

- Cellular Handsets and Accessories
- Personal Digital Assistants
- Notebooks and Handhelds
- Portable Instrumentation
- Digital Cameras
- Peripherals
- Audio Players

### Marking Information



T2 = Device Marking Code

### Dimensions and Pin Configuration

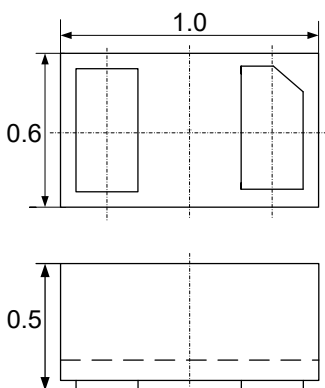

Package Dimensions

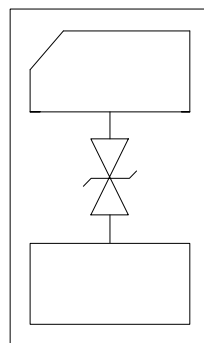

Circuit and Pin Schematic

### Ordering Information

Part Number	Packaging	Reel Size
AU1211P1	10000/Tape & Reel	7 inch

**Absolute Maximum Ratings (T<sub>A</sub>=25°C unless otherwise specified)**

Parameter	Symbol	Value	Unit
Peak Pulse Power (8/20μs)	Ppk	375	W
Peak Pulse Current (8/20μs)	Ipp	15	A
ESD per IEC 61000-4-2 (Air) ESD per IEC 61000-4-2 (Contact)	VESD	±30 ±30	kV
Operating Temperature Range	TJ	-55 to +125	°C
Storage Temperature Range	Tstg	-55 to +150	°C

**Electrical Characteristics (T<sub>A</sub>=25°C unless otherwise specified)**

Parameter	Symbol	Min	Typ	Max	Unit	Test Condition
Reverse Working Voltage	VRWM			12	V	
Breakdown Voltage	VBR	13.3			V	IT = 1mA
Reverse Leakage Current	IR			0.2	μA	VRWM = 12V
Clamping Voltage	VC			16	V	I <sub>PP</sub> = 1A (8 x 20μs pulse)
Clamping Voltage	VC			25	V	I <sub>PP</sub> = 15A (8 x 20μs pulse)
Junction Capacitance	CJ		35		pF	VR = 0V, f = 1MHz

**Typical Performance Characteristics (TA=25°C unless otherwise Specified)**

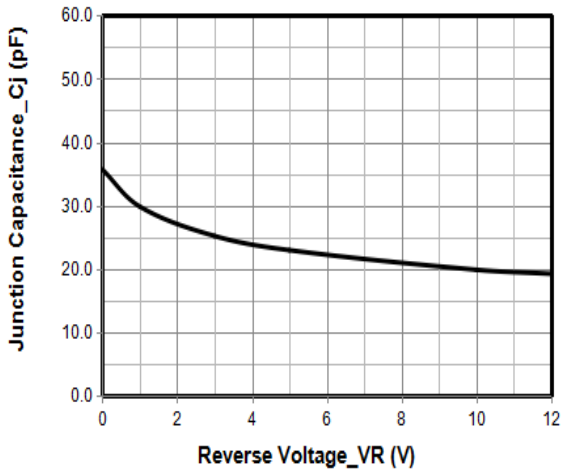

**Junction Capacitance vs. Reverse Voltage**

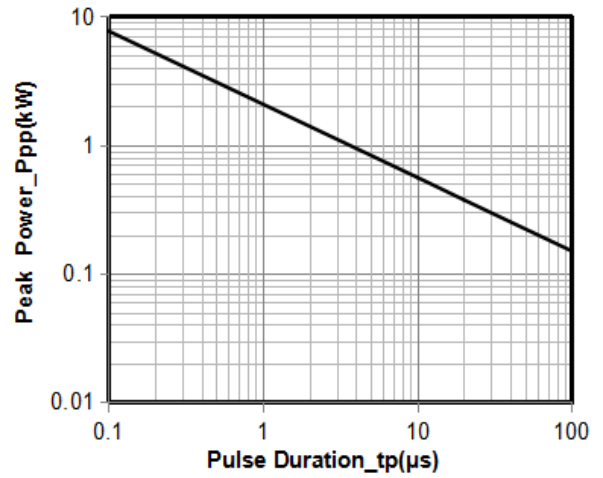

**Peak Pulse Power vs. Pulse Time**

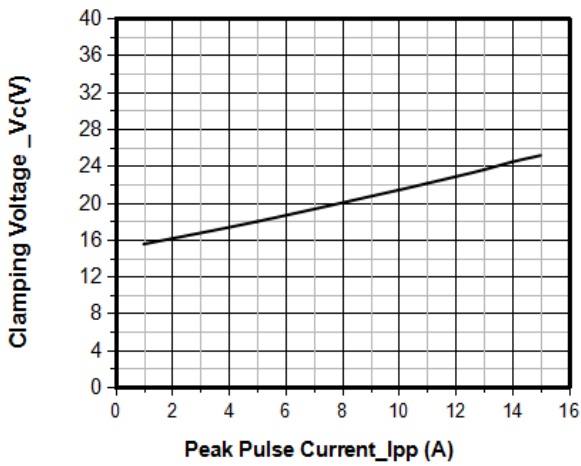

**Clamping Voltage vs. Peak Pulse Current**

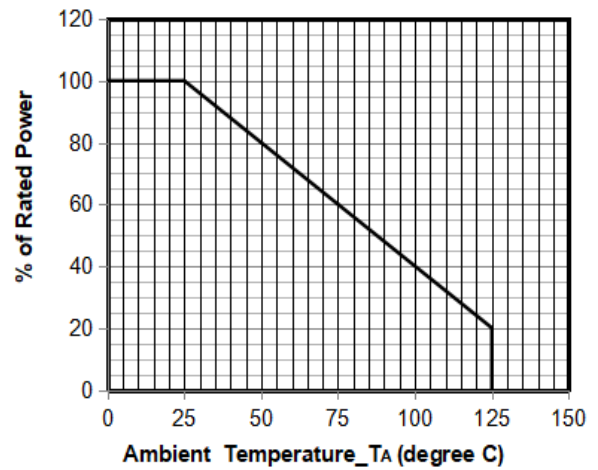

**Power Derating Curve**

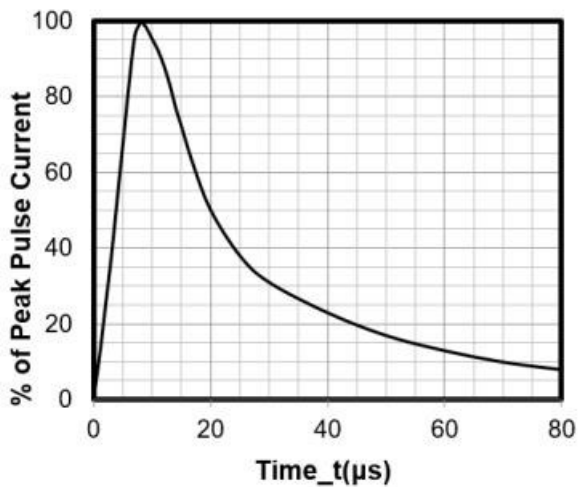

**8 X 20μs Pulse Waveform**

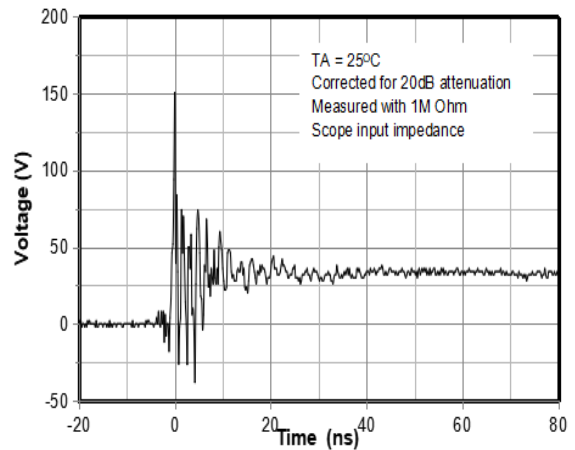

**ESD Clamping Voltage**

**8 kV Contact per IEC61000-4-2**

### DFN1006-2 Package Outline Drawing

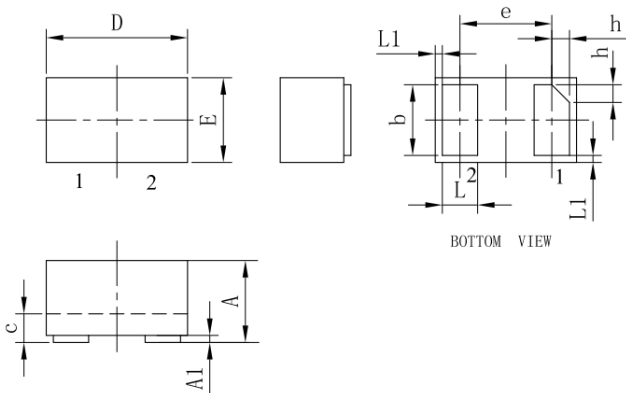

SYM	DIMENSIONS					
	MILLIMETERS			INCHES		
	MIN	NOM	MAX	MIN	NOM	MAX
A	0.45	0.50	0.55	0.018	0.020	0.022
A1	0.00	0.02	0.05	0.000	0.001	0.002
b	0.45	0.50	0.55	0.018	0.020	0.022
c	0.12	0.15	0.18	0.005	0.006	0.007
D	0.95	1.00	1.05	0.037	0.039	0.041
e	0.65 BSC			0.026 BSC		
E	0.55	0.60	0.65	0.022	0.024	0.026
L	0.20	0.25	0.30	0.008	0.010	0.012
L1	0.05REF			0.002REF		
h	0.07	0.12	0.17	0.003	0.005	0.007

### Suggested Land Pattern

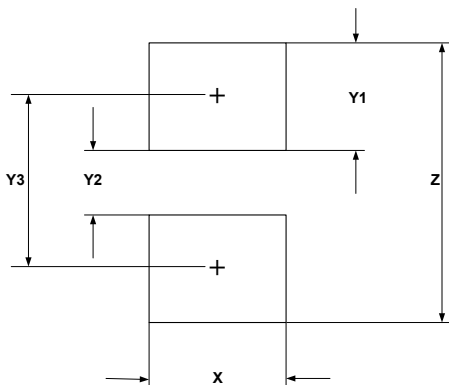

SYM	DIMENSIONS	
	MILLIMETERS	INCHES
X	0.60	0.024
Y1	0.50	0.020
Y2	0.30	0.012
Y3	0.80	0.032
Z	1.30	0.052

### Contact Information

Applied Power Microelectronics Inc.  
 Website: <http://www.appliedpowermicro.com>  
 Email: [sales@appliedpowermicro.com](mailto:sales@appliedpowermicro.com)  
 Phone: +86 (0519) 8399 3606