

Description

The AU0761M1 is a bi-directional TVS diode, utilizing leading monolithic silicon technology to provide fast response time and low ESD clamping voltage, making this device an ideal solution for protecting voltage sensitive data and power line. The AU0761M1 complies with the IEC 61000-4-2 (ESD) with ± 15 kV air and ± 8 kV contact discharge. It is assembled into an ultra-small 1.0x0.6x0.5mm lead-free 0402 package. The small size and high ESD surge protection make AU0761M1 an ideal choice to protect cell phone, digital cameras, audio players and many other portable applications.

Features

- Ultra small package: 1.0x0.6x0.5mm
- Protects one data or power line
- Ultra low leakage: nA level
- Operating voltage: 5V
- Low clamping voltage
- 2-pin leadless package
- Complies with following standards:
 - IEC 61000-4-2 (ESD) immunity test
 - Air discharge: ± 15 kV
 - Contact discharge: ± 8 kV
 - IEC61000-4-5 (Lightning) 2A (8/20 μ s)
- RoHS Compliant

Mechanical Characteristics

- Package: 0402
- Lead Finish: Sn
- Case Material: "Green" Molding Compound.
- Moisture Sensitivity: Level 3 per J-STD-020
- Terminal Connections: See Diagram Below
- Marking Information: See Below

Applications

- Cellular Handsets and Accessories
- Personal Digital Assistants
- Notebooks and Handhelds
- Portable Instrumentation
- Digital Cameras
- Peripherals
- Audio Players
- Keypads, Side Keys, LCD Displays

Ordering Information

| Part Number | Packaging | Reel Size |
|-------------|-------------------|-----------|
| AU0761M1 | 10000/Tape & Reel | 7 inch |

Dimensions and Pin Configuration

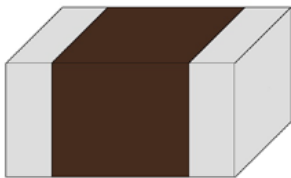

Package Outline

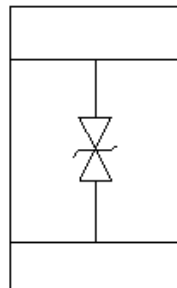

Circuit Schematic

Absolute Maximum Ratings ($T_A=25^{\circ}\text{C}$ unless otherwise specified)

| Parameter | Symbol | Value | Unit |
|--|------------------|-------------|--------------------|
| Peak Pulse Power (8/20 μs) | Ppk | 25 | W |
| Peak Pulse Current (8/20 μs) | I _{PP} | 2 | A |
| ESD per IEC 61000-4-2 (Air) | V _{ESD} | ± 15 | kV |
| ESD per IEC 61000-4-2 (Contact) | | ± 8 | |
| Operating Temperature Range | T _J | -55 to +125 | $^{\circ}\text{C}$ |
| Storage Temperature Range | T _{stg} | -55 to +150 | $^{\circ}\text{C}$ |

Electrical Characteristics ($T_A=25^{\circ}\text{C}$ unless otherwise specified)

| Parameter | Symbol | Min | Typ | Max | Unit | Test Condition |
|-------------------------|------------------|-----|-----|------|---------------|-------------------------------|
| Reverse Working Voltage | V _{RWM} | | | 7 | V | |
| Breakdown Voltage | V _{BR} | 6 | | | V | I _T = 1mA |
| Reverse Leakage Current | I _R | | | 0.2 | μA | V _{RWM} = 7V |
| Clamping Voltage | V _C | | | 8 | V | I _{PP} = 1A |
| Clamping Voltage | V _C | | | 12.5 | V | I _{PP} = 2A |
| Junction Capacitance | C _J | | | 10 | pF | V _R = 0V, f = 1MHz |

Typical Performance Characteristics ($T_A=25^\circ\text{C}$ unless otherwise Specified)

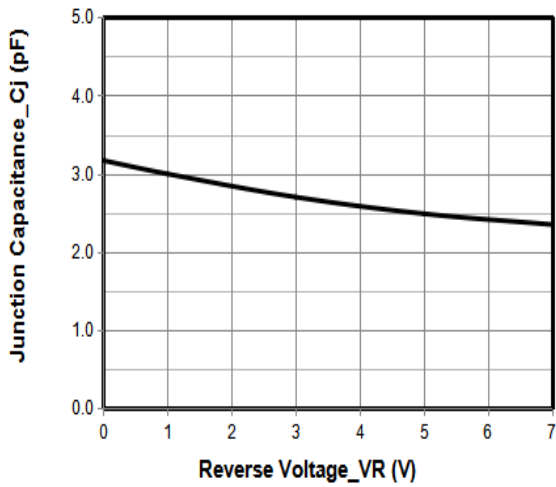

Junction Capacitance vs. Reverse Voltage

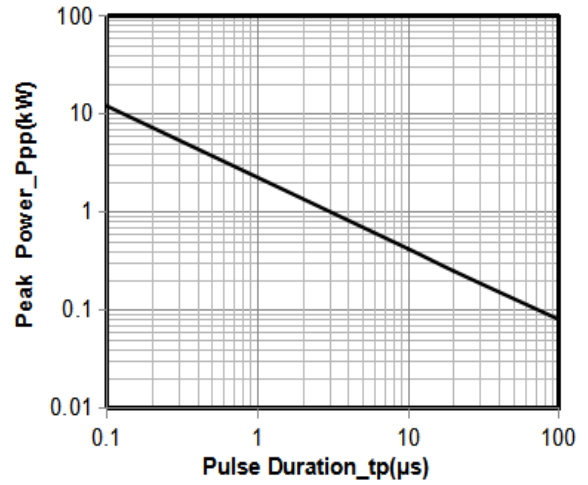

Peak Pulse Power vs. Pulse Time

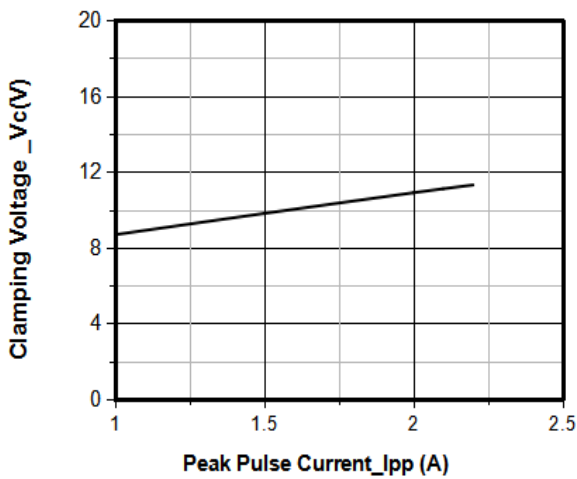

Clamping Voltage vs. Peak Pulse Current ($t_p = 8/20\mu\text{s}$)

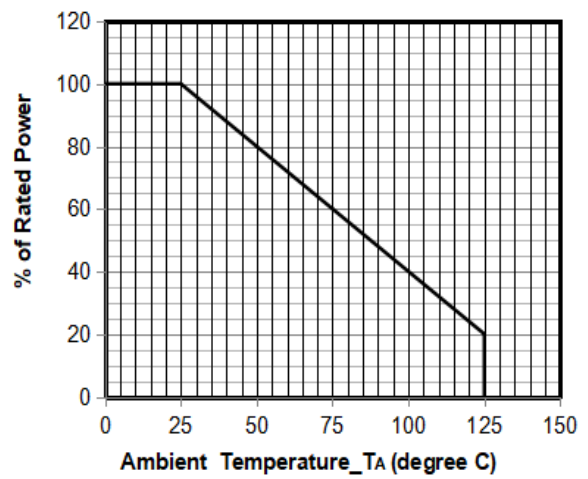

Power Derating Curve

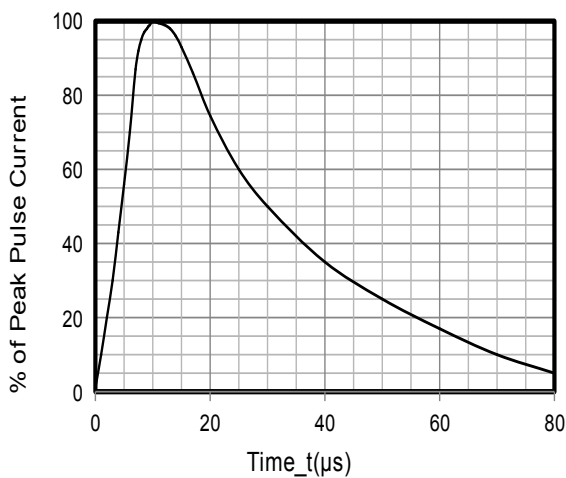

8 X 20μs Pulse Waveform

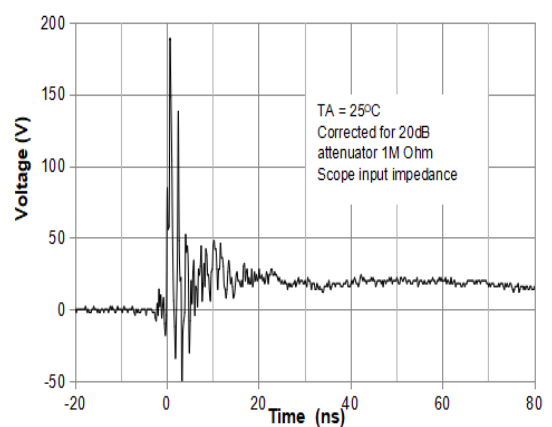

**ESD Clamping Voltage
8 kV Contact per IEC61000-4-2**

0402 Package Outline Drawing

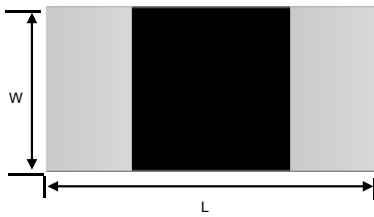

Top

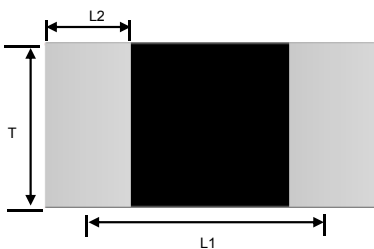

Side View

| SYM | DIMENSIONS | | | | | |
|-----|-------------|------|------|-----------|-------|-------|
| | MILLIMETERS | | | INCHES | | |
| | MIN | NOM | MAX | MIN | NOM | MAX |
| W | 0.45 | 0.55 | 0.65 | 0.018 | 0.022 | 0.026 |
| L | 0.95 | 1.00 | 1.05 | 0.038 | 0.040 | 0.042 |
| T | 0.45 | 0.55 | 0.65 | 0.018 | 0.022 | 0.026 |
| L1 | 0.75 BSC | | | 0.030 BSC | | |
| L2 | 0.15 | 0.20 | 0.25 | 0.006 | 0.008 | 0.010 |

Suggested Land Pattern

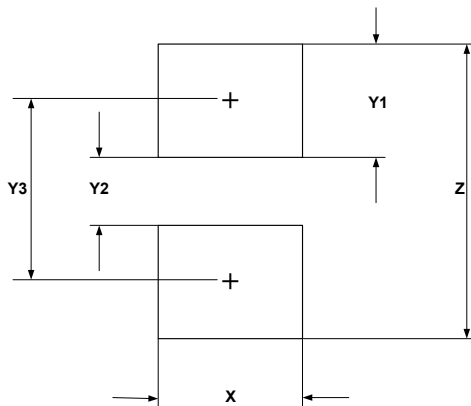

| SYM | DIMENSIONS | |
|-----|-------------|--------|
| | MILLIMETERS | INCHES |
| X | 0.60 | 0.024 |
| Y1 | 0.50 | 0.020 |
| Y2 | 0.30 | 0.012 |
| Y3 | 0.80 | 0.032 |
| Z | 1.30 | 0.052 |

Contact Information

Applied Power Microelectronics Co., Ltd.

Website: <http://www.appliedpowermicro.com>

Email: sales@appliedpowermicro.com

Phone: +86 (0519) 8399 3606