

### Description

The AU0561P1 is a bi-directional TVS diode, utilizing leading monolithic silicon technology to provide fast response time, very low capacitance and low ESD clamping voltage, making this device an ideal solution for protecting voltage sensitive data and power line. The AU0561P1 complies with the IEC 61000-4-2 (ESD) with  $\pm 20\text{kV}$  air and  $\pm 20\text{kV}$  contact discharge. It is assembled into an ultra-small 1.0x0.6x0.5mm lead-free DFN package. The small size and very low capacitance make AU0561P1 an ideal choice to protect cell phone, digital cameras, audio players, data interface and many other portable applications.

### Features

- Ultra small package: 1.0x0.6x0.5mm
- Protects one data or power line
- Very low capacitance: 2.5pF typical
- Ultra low leakage: nA level
- Operating voltage: 5V
- Low clamping voltage
- 2-pin leadless package
- Complies with following standards:
  - IEC 61000-4-2 (ESD) immunity test  
Air discharge:  $\pm 20\text{kV}$   
Contact discharge:  $\pm 20\text{kV}$
  - EC61000-4-5 (Lightning) 2A (8/20 $\mu\text{s}$ )
- RoHS compliant

### Dimensions and Pin Configuration

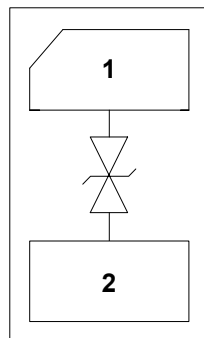
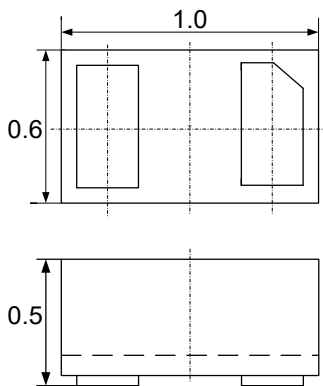

Package Dimensions (mm)

Circuit and Pin Schematic

### Mechanical Characteristics

- Package: DFN1006-2 (1.0x0.6x0.5mm)
- Case Material: “Green” Molding Compound.
- Terminal Connections: See Diagram Below
- Marking Information: See Below

### Applications

- Cellular Handsets and Accessories
- Personal Digital Assistants
- Notebooks and Handhelds
- Portable Instrumentation
- Digital Cameras
- Peripherals
- Audio Players
- Keypads, Side Keys, USB 2.0, LCD Displays

### Marking Information

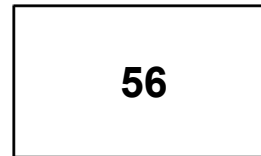

### Ordering Information

Part Number	Packaging	Reel Size
AU0561P1	10000/Tape & Reel	7 inch

**Absolute Maximum Ratings (T<sub>A</sub>=25°C unless otherwise specified)**

Parameter	Symbol	Value	Unit
ESD per IEC 61000-4-2 (Air)	VESD	±20	kV
ESD per IEC 61000-4-2 (Contact)		±20	
Peak Pulse Power (8/20µs)	PPK	25	W
Peak Pulse Current	IPP	2	A
Operating Temperature Range	TJ	-55 to +125	°C
Storage Temperature Range	Tstg	-55 to +150	°C

**Electrical Characteristics (T<sub>A</sub>=25°C unless otherwise specified)**

Parameter	Symbol	Min	Typ	Max	Unit	Test Condition
Reverse Working Voltage	VRWM			5	V	Pin 1 to Pin 2 or Pin 2 to Pin 1
Breakdown Voltage	VBR	6			V	IT = 1mA, Pin 1 to Pin 2 or Pin 1 to Pin 2
Reverse Leakage Current	IR			0.2	µA	VRWM = 5V, Pin 1 to Pin 2 or Pin 1 to Pin 2
Clamping Voltage	VC			10	V	IPP = 1A (8 x 20µs pulse), Pin 1 to Pin 2 or Pin 1 to Pin 2
Clamping Voltage	VC			12.5	V	IPP = 2A (8 x 20µs pulse), Pin 1 to Pin 2 or Pin 1 to Pin 2
Junction Capacitance	CJ		2.5	3	pF	VR = 0V, f = 1MHz

**Typical Performance Characteristics ( $T_A=25^\circ\text{C}$  unless otherwise Specified)**

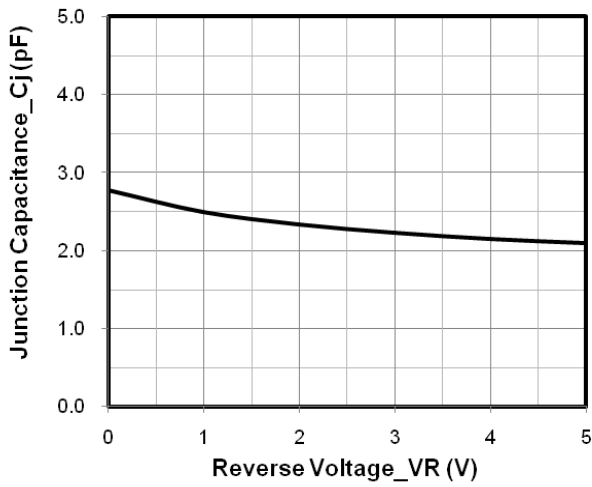

**Junction Capacitance vs. Reverse Voltage**

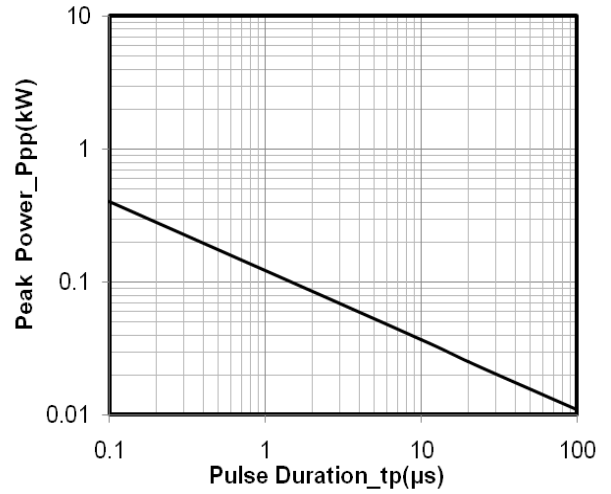

**Peak Pulse Power vs. Pulse Time**

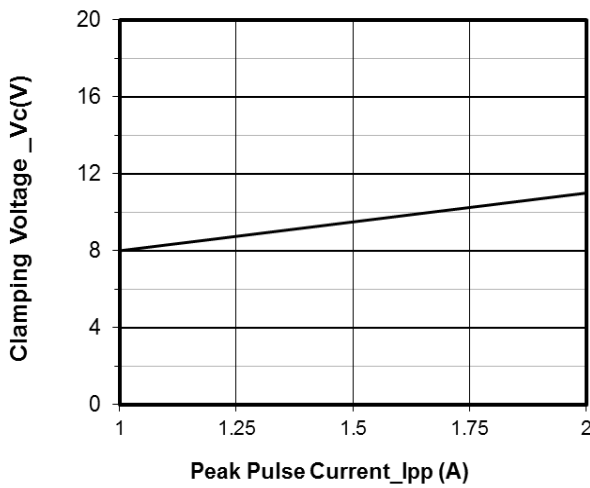

**Clamping Voltage vs. Peak Pulse Current ( $t_p = 8/20\mu\text{s}$ )**

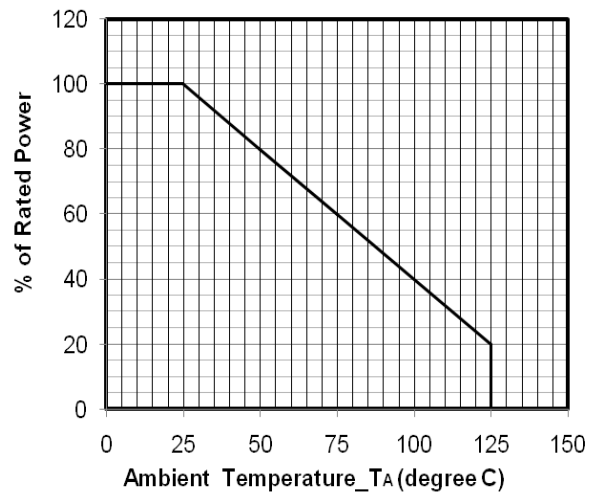

**Power Derating Curve**

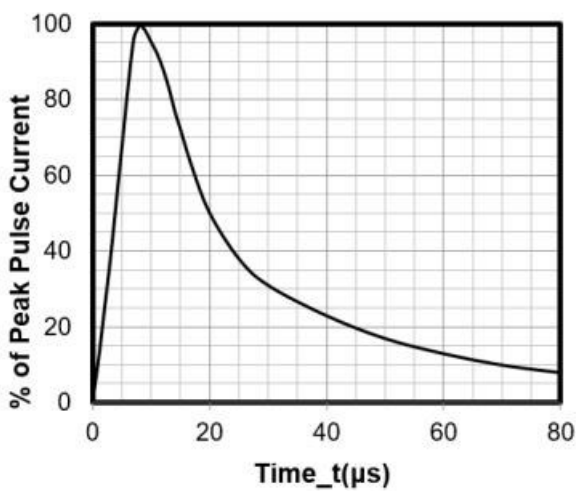

**8 X 20μs Pulse Waveform**

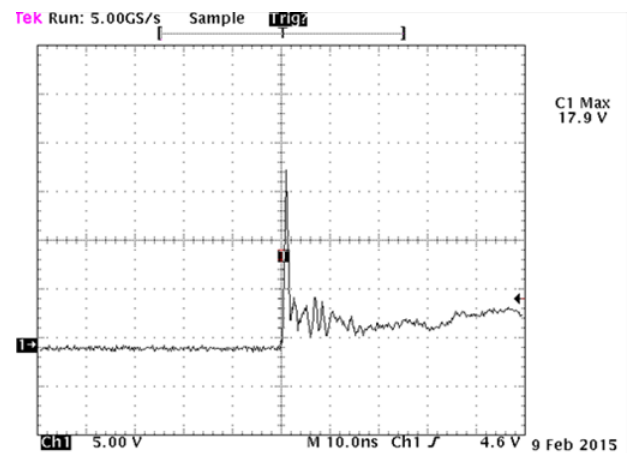

**Note: Data is taken with a 10x attenuator**

**ESD Clamping Voltage**

**+8 kV Contact per IEC61000-4-2**

**AU0561P1 on USB 2.0 Port Application**

The USB interface consists of Data (D- and D+) lines and a 5.25V voltage bus. Since these pins are part of the connector, they are vulnerable to ESD and cable discharge events. The AU0561P1 is designed to protect two USB data line connections (D-, D+). When the voltage on the data lines exceed the bus voltage (plus one diode drop), the internal rectifiers are forward biased conducting the transient current away from the protected controller chip. The TVS diode directs the surge to ground. The AU0551P1 acts to suppress ESD strikes directly on the voltage bus. Thus, both power and data pins are protected with two AU0561P1 and one AU0551P1.

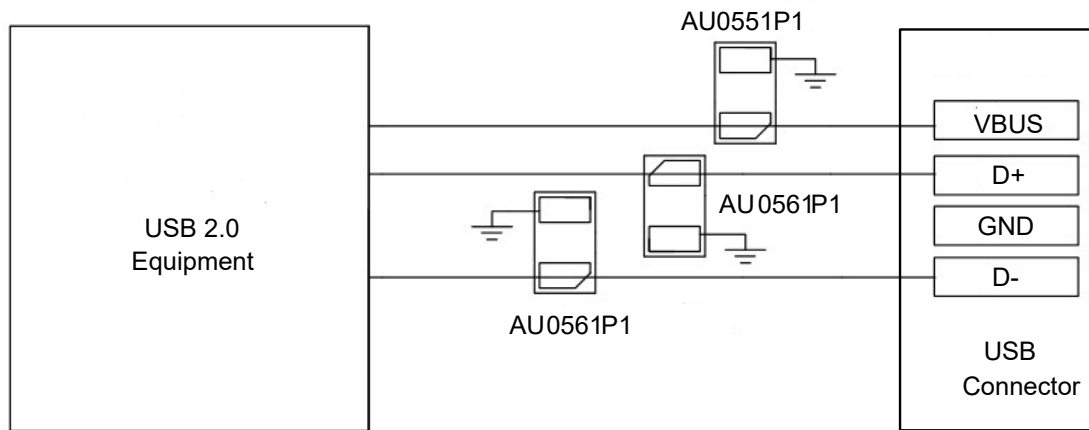

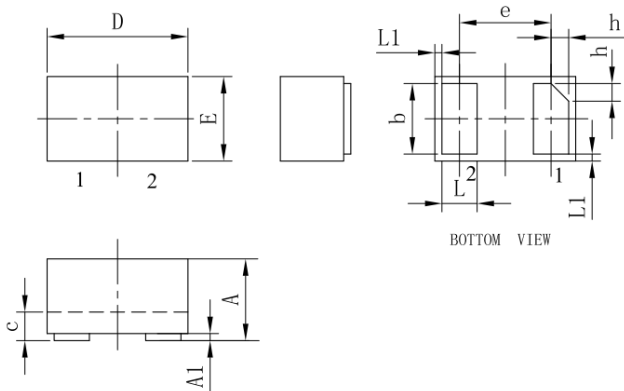
**DFN1006-2 Package Outline Drawing**

SYM	DIMENSIONS					
	MILLIMETERS			INCHES		
	MIN	NOM	MAX	MIN	NOM	MAX
A	0.45	0.50	0.55	0.018	0.020	0.022
A1	0.00	0.02	0.05	0.000	0.001	0.002
b	0.45	0.50	0.55	0.018	0.020	0.022
c	0.12	0.15	0.18	0.005	0.006	0.007
D	0.95	1.00	1.05	0.037	0.039	0.041
e	0.65 BSC			0.026 BSC		
E	0.55	0.60	0.65	0.022	0.024	0.026
L	0.20	0.25	0.30	0.008	0.010	0.012
L1	0.05REF			0.002REF		
h	0.07	0.12	0.17	0.003	0.005	0.007

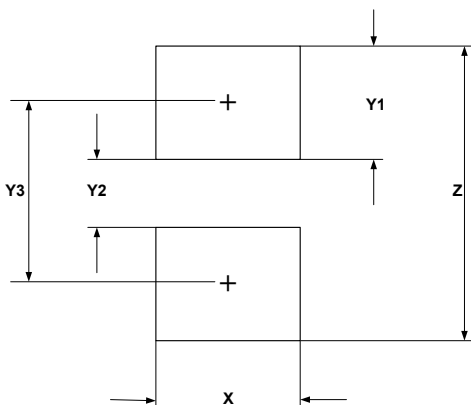
**Suggested Land Pattern**

SYM	DIMENSIONS	
	MILLIMETERS	INCHES
X	0.60	0.024
Y1	0.50	0.020
Y2	0.30	0.012
Y3	0.80	0.032
Z	1.30	0.052

**Contact Information**

Applied Power Microelectronics Inc.

 Website: <http://www.appliedpowermicro.com>

 Email: [sales@appliedpowermicro.com](mailto:sales@appliedpowermicro.com)

Phone: +86 (0519) 8399 3606