

Description

The AU0533S1 is a 3-line TVS diode array, utilizing leading monolithic silicon technology to provide fast response time and low ESD clamping voltage, making this device an ideal solution for protecting voltage sensitive high-speed data lines. The AU0533S1 complies with the IEC 61000-4-2 (ESD) with $\pm 30\text{kV}$ air and $\pm 30\text{kV}$ contact discharge. It is assembled into a 4-pin SOT-143 lead-free package. The small size, high ESD surge protection make AU0533S1 an ideal choice to protect cell phone, digital video interfaces, high speed data ports, and many other portable applications.

Features

- Ultra low leakage: nA level
- Operating voltage: 5V
- Low clamping voltage
- 4-pin SOT-143 package
- Protects two data lines and one power line
- Complies with following standards:
 - IEC 61000-4-2 (ESD) immunity test
 - Air discharge: $\pm 30\text{kV}$
 - Contact discharge: $\pm 30\text{kV}$
 - IEC61000-4-5 (Lightning) 8A (8/20 μs)
- RoHS Compliant

Mechanical Characteristics

- Package: SOT-143
- Lead Finish: Matte Tin
- Case Material: “Green” Molding Compound.
- Terminal Connections: See Diagram Below
- Marking Information: See Below

Applications

- Cellular Handsets and Accessories
- Notebooks and Handhelds
- Personal Digital Assistants
- Portable Instrumentation
- Digital Cameras
- Peripherals
- Audio Players, Keypads, Side Keys, LCD
- USB 2.0

Marking Information

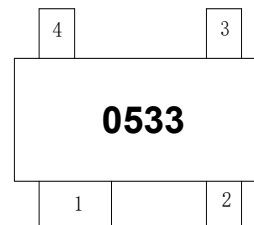

0533 = Device Marking Code
 Pin1 is ground

Dimensions and Pin Configuration

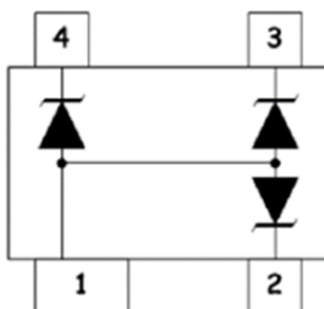

Pin Schematic

Ordering Information

Part Number	Packaging	Reel Size
AU0533S1	3000/Tape & Reel	7 inch

Absolute Maximum Ratings ($T_A=25^{\circ}\text{C}$ unless otherwise specified)

Parameter	Symbol	Value	Unit
Peak Pulse Power (8/20 μs)	Ppk	100	W
Peak Pulse Current (8/20 μs)	I _{PP}	8	A
ESD per IEC 61000-4-2 (Air) ESD per IEC 61000-4-2 (Contact)	V _{ESD}	± 30 ± 30	kV
Operating Temperature Range	T _J	-55 to +125	$^{\circ}\text{C}$
Storage Temperature Range	T _{stg}	-55 to +150	$^{\circ}\text{C}$

Electrical Characteristics ($T_A=25^{\circ}\text{C}$ unless otherwise specified)

Parameter	Symbol	Min	Typ	Max	Unit	Test Condition
Reverse Working Voltage	V _{RWM}			5	V	Any I/O pin to ground
Breakdown Voltage	V _{BR}	6			V	I _T = 1mA, any I/O pin to ground
Reverse Leakage Current	I _R			0.2	μA	V _{RWM} = 5V, any I/O pin to ground
Clamping Voltage	V _C			8	V	I _{PP} = 1A (8 x 20 μs pulse), any I/O pin to ground
Clamping Voltage	V _C			12.5	V	I _{PP} = 8A (8 x 20 μs pulse), any I/O pin to ground
Junction Capacitance	C _J		30		pF	V _R = 0V, f = 1MHz, between I/O pins
Junction Capacitance	C _J		60		pF	V _R = 0V, f = 1MHz, any I/O pin to ground

Typical Performance Characteristics ($T_A=25^\circ\text{C}$ unless otherwise Specified)

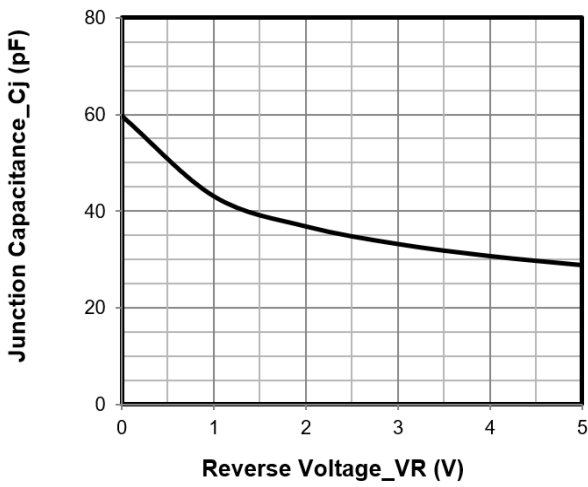

Junction Capacitance vs. Reverse Voltage

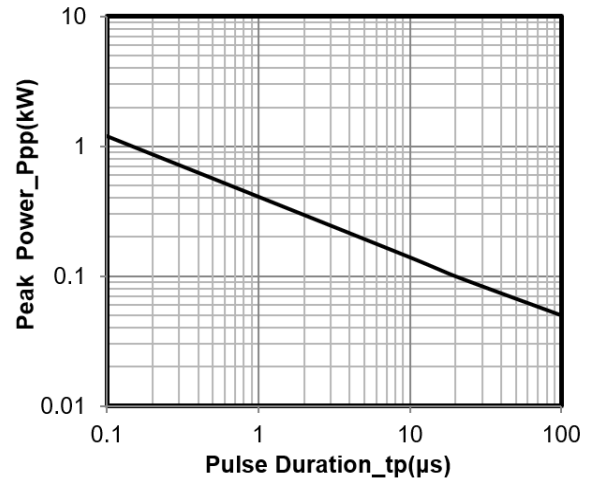

Peak Pulse Power vs. Pulse Time

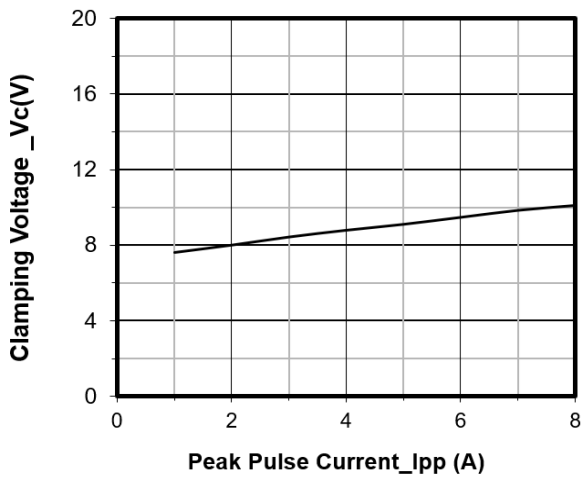

Clamping Voltage vs. Peak Pulse Current

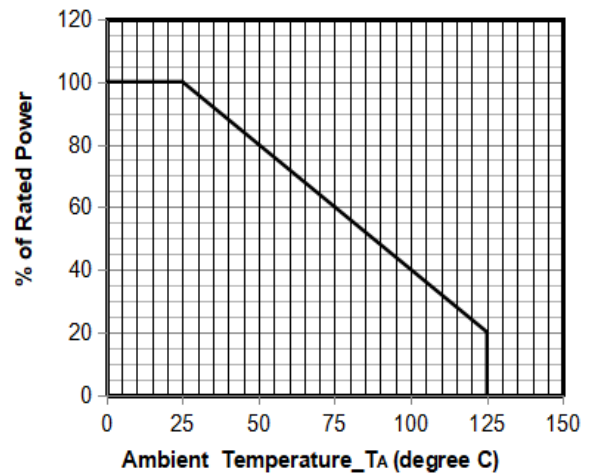

Power Derating Curve

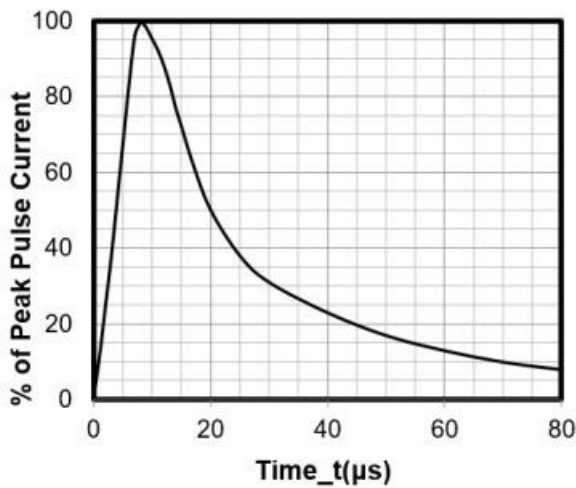

8 X 20μs Pulse Waveform

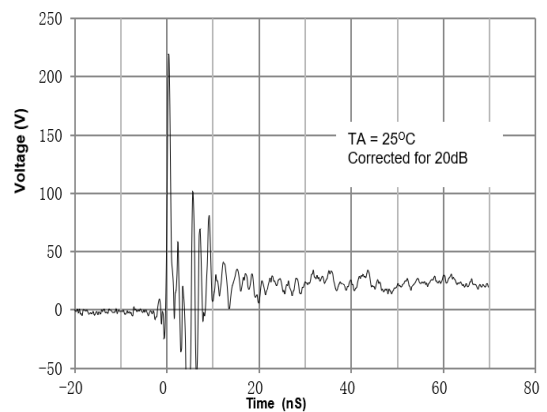

ESD Clamping Voltage
8 kV Contact per IEC61000-4-2

SOT-143 Package Outline Drawing

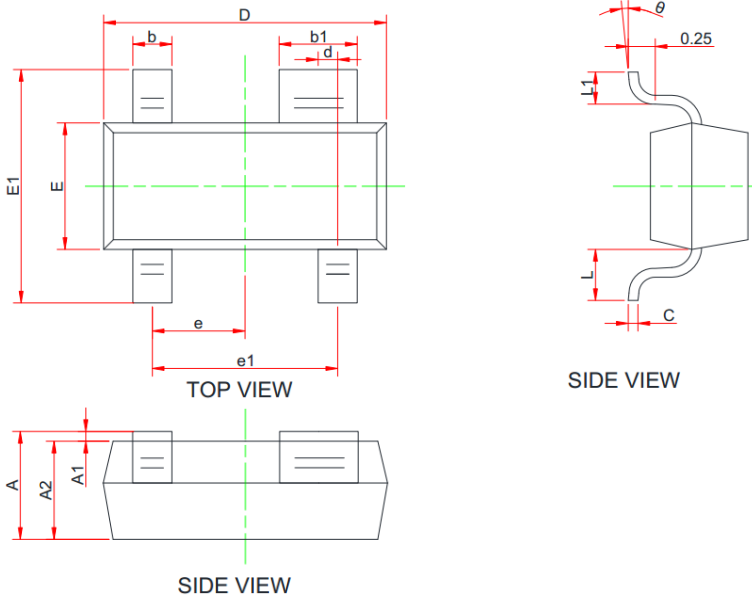

SYS YM	MILLIMETERS		
	MIN	NOM	MAX
A	0.90	-	1.15
A1	0.00	0.05	0.10
A2	0.90	-	1.05
b	0.30	0.40	0.50
b1	0.75	-	0.90
c	0.08	-	0.15
D	2.80	2.90	3.00
d	0.20 Typ		
E	1.20	1.30	1.40
E1	2.25	2.40	2.55
e	0.95 Typ		
e1	1.80	1.90	2.00
L	0.55 Ref		
L1	0.30	0.40	0.50
Θ	0°	-	8°

Suggested Land Pattern

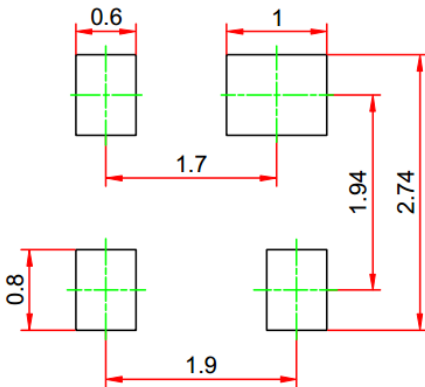

Unit(mm)

Contact Information

Applied Power Microelectronics Inc.
 Website: <http://www.appliedpowermicro.com>
 Email: sales@appliedpowermicro.com
 Phone: +86 (0519) 8399 3606