

## Description

The ASM1235 is designed for asymmetrical (12V to 35V) protection in multi-point data transmission application. The ASM1235 replace four discrete components by integrating two 12V and two 35V TVS diodes in a single package. The ASM1235 complies with the IEC 61000-4-2 (ESD) with  $\pm 25\text{kV}$  air and  $\pm 20\text{kV}$  contact discharge. It is assembled into a lead-free SOT-23 package. It is designed to protect components which are connected to data and transmission lines from voltage surges.

## Features

- 300W peak pulse power (8/20 $\mu\text{s}$ )
- Ultra low leakage: nA level
- Operating voltage: 12V or 35V
- Low clamping voltage
- Complies with following standards:
  - IEC 61000-4-2 (ESD) immunity test
    - Air discharge:  $\pm 25\text{kV}$
    - Contact discharge:  $\pm 20\text{kV}$
  - IEC61000-4-5 (Lightning) 4A (pin1 or 2 to 3)
  - IEC61000-4-5 (Lightning) 11A (pin3 to 1 or 3) (8/20 $\mu\text{s}$ )
- RoHS Compliant

## Dimensions and Pin Configuration

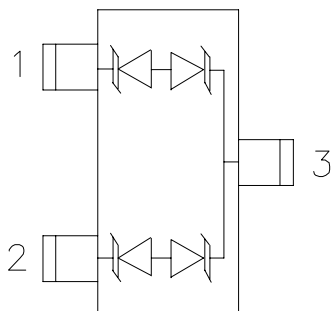

Pin Schematic

## Mechanical Characteristics

- Package: SOT-23
- Lead Finish: Matte Tin
- Case Material: "Green" Molding Compound.
- Terminal Connections: See Diagram Below
- Marking Information: See Below

## Applications

- Wireless System
- Networks
- Portable Instrumentation
- RS485 Ports

## Marking Information

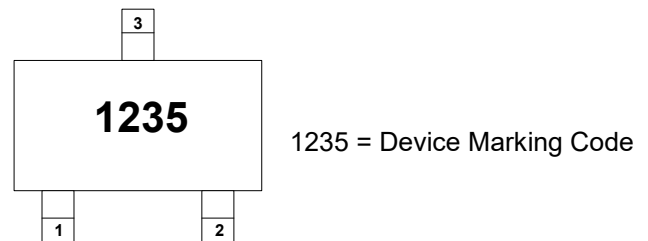

## Ordering Information

Part Number	Packaging	Reel Size
ASM1235	3000/Tape & Reel	7 inch

**Absolute Maximum Ratings (T<sub>A</sub>=25°C unless otherwise specified)**

Parameter	Symbol	Value	Unit
Peak Pulse Power (8/20µs)	Ppk	300	W
Peak Pulse Current (8/20µs) (Pin 1 or 2 to 3)	Ipp	4	A
Peak Pulse Current (8/20µs) (Pin 3 to 1 or 2)	Ipp	11	A
ESD per IEC 61000-4-2 (Air)	VESD	±25	kV
ESD per IEC 61000-4-2 (Contact)		±20	
Operating Temperature Range	TJ	-40 to +125	°C
Storage Temperature Range	Tstg	-55 to +150	°C

**Electrical Characteristics (T<sub>A</sub>=25°C unless otherwise specified)**

Parameter	Symbol	Pin 1 or pin 2 to pin3 (35V TVS)			Pin 3 to pin 1 or pin 2 (12V TVS)			Unit	Test Condition
		Min	Typ	Max	Min	Typ	Max		
Reverse Working Voltage	VRWM			35			12	V	
Breakdown Voltage	VBR	36			13.3			V	IT = 1mA
Reverse Leakage Current	IR			0.5			0.5	µA	VR = VRWM
Clamping Voltage	VC			50			18	V	I <sub>PP</sub> = 1A
Clamping Voltage	VC			72			24	V	I <sub>PP</sub> = 4A (pin1 or pin 2 to pin3) I <sub>PP</sub> = 11A (pin3 to pin1 or pin2)
Junction Capacitance	CJ			28			50	pF	VR = 0V, f = 1MHz

**Typical Performance Characteristics ( $T_A=25^\circ\text{C}$  unless otherwise Specified)**

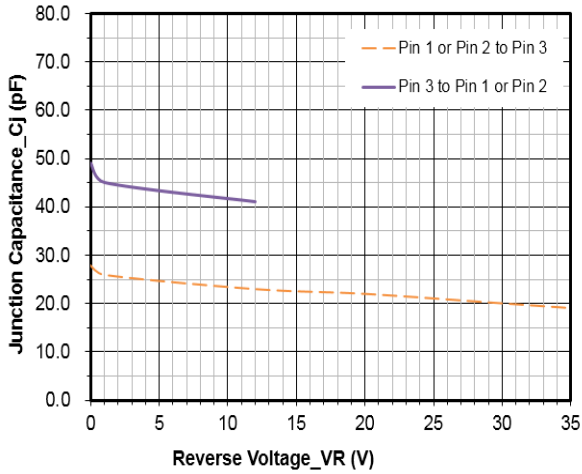

**Junction Capacitance vs. Reverse Voltage**

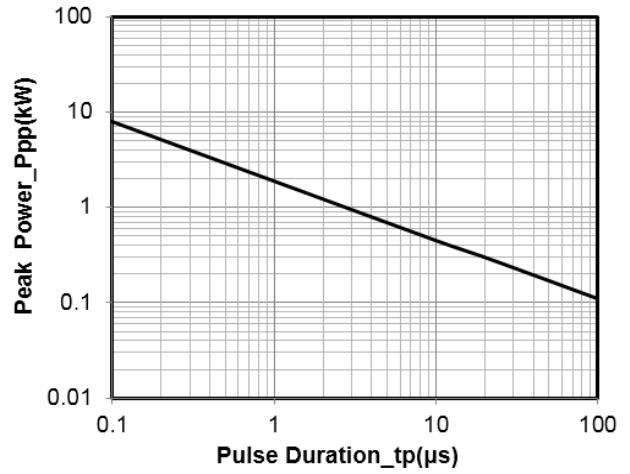

**Peak Pulse Power vs. Pulse Time**

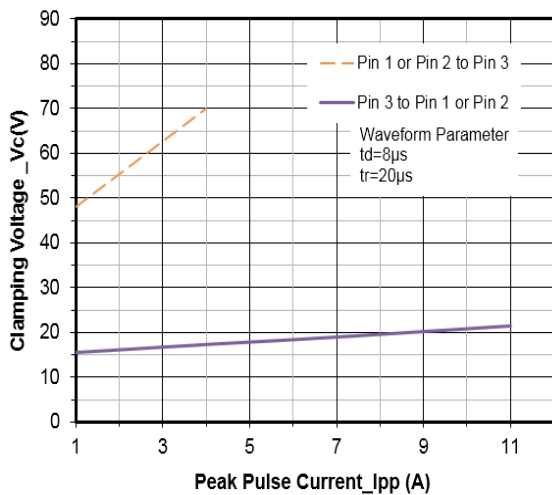

**Clamping Voltage vs. Peak Pulse Current**

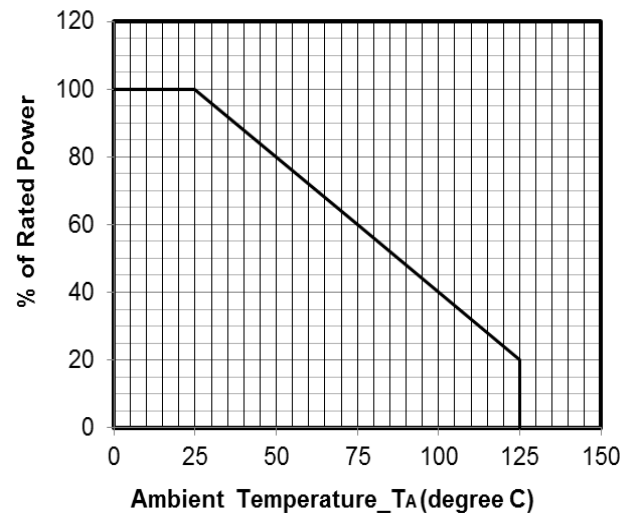

**Power Derating Curve**

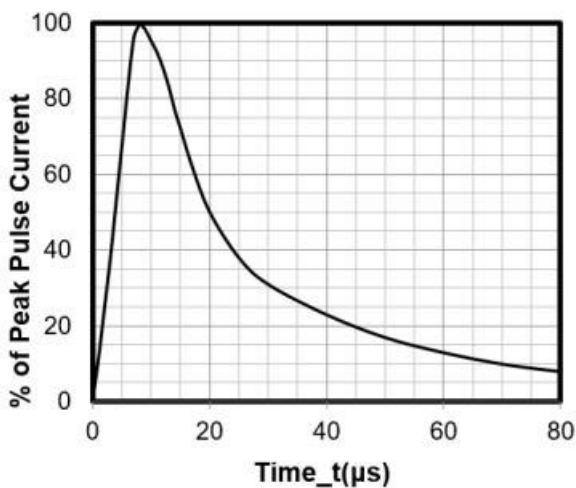

**8 X 20μs Pulse Waveform**

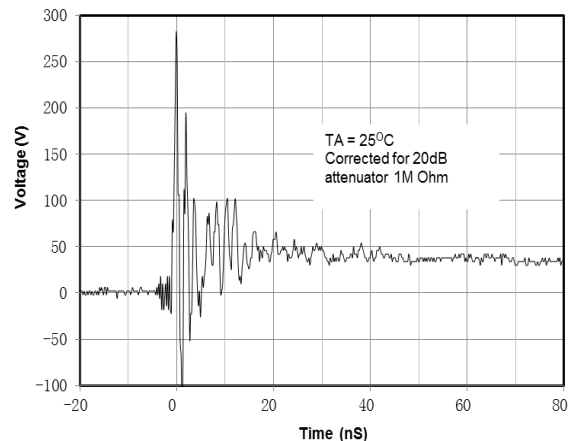

**ESD Clamping Voltage**

**8 kV Contact per IEC61000-4-2**

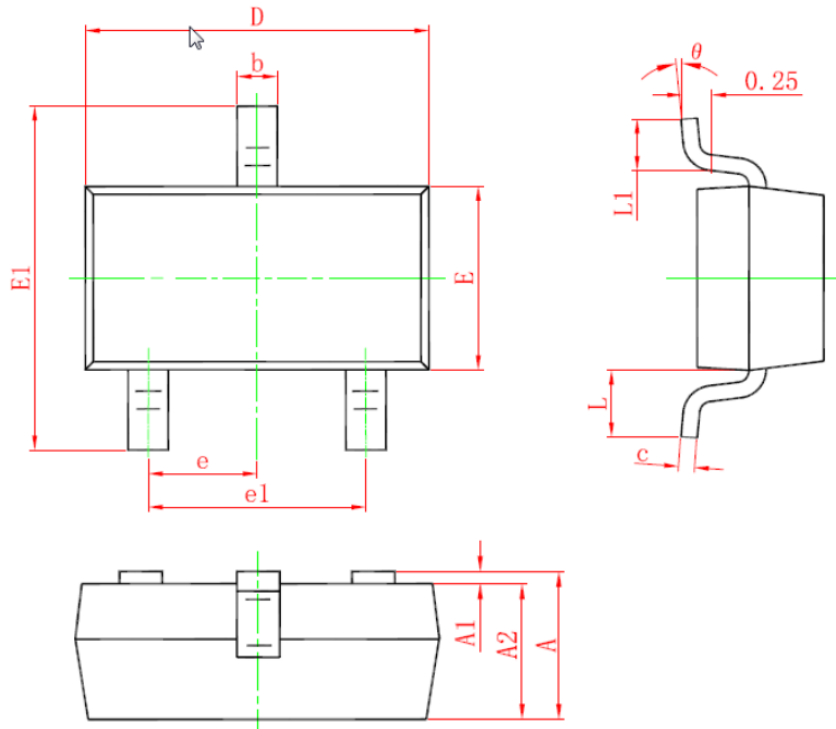
**SOT-23 Package Outline Drawing**

SYM	DIMENSIONS					
	MILLIMETERS			INCHES		
	MIN	NOM	MAX	MIN	NOM	MAX
A	0.90	--	1.15	0.035	--	0.045
A1	0.00	--	0.10	0.000	--	0.004
A2	0.90	--	1.05	0.035	--	0.041
b	0.30	--	0.50	0.012	--	0.020
c	0.08	--	0.15	0.003	--	0.006
D	2.80	--	3.00	0.110	--	0.118
E	1.20	--	1.40	0.047	--	0.055
E1	2.25	--	2.55	0.089		0.100
e	0.95TYP			0.037TYP		
e1	1.80	--	2.00	0.071	--	0.079
L	0.55REF			0.022REF		
L1	0.30	--	0.50	0.012	--	0.020
θ	0°	--	8°	0°	--	8°

## Suggested Land Pattern

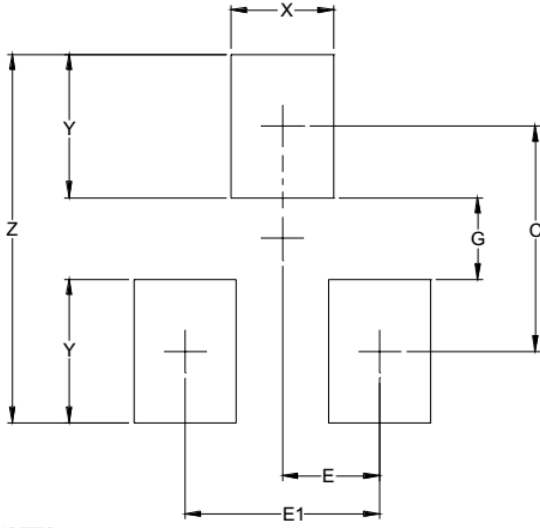

SYM	DIMENSIONS	
	INCHES	MILLIMETERS
C	0.087	(2.20)
E	0.037	0.95
E1	0.075	1.90
G	0.031	0.80
X	0.039	1.00
Y	0.055	1.40
Z	0.141	3.60

## Contact Information

Applied Power Microelectronics Inc.

Website: <http://www.appliedpowermicro.com>

Email: [sales@appliedpowermicro.com](mailto:sales@appliedpowermicro.com)

Phone: +86 (0519) 8399 3606