

## Description

The ASD30C-LS is designed to replace multilayer varistors (MLVs) in portable applications such as cell phones, notebook computers and PDA's, using monolithic silicon technology to provide fast response time and ultra low ESD clamping voltage, making this device an ideal solution for protecting sensitive semiconductor components from damage. The ASD30C-LS complies with the IEC 61000-4-2 (ESD) with  $\pm 30\text{kV}$  air and  $\pm 30\text{kV}$  contact discharge. The ASD30C-LS is assembled into a lead-free SOD-323 package and will protect one bidirectional line. These devices will fit on the same PCB pad area as an 0805 MLV device.

## Features

- 500W peak pulse power (8/20 $\mu\text{s}$ )
- Protects one data or power line
- Ultra low leakage: nA level
- Operating voltage: 30V
- Ultra low clamping voltage
- Complies with following standards:
  - IEC 61000-4-2 (ESD) immunity test
    - Air discharge:  $\pm 30\text{kV}$
    - Contact discharge:  $\pm 30\text{kV}$
  - IEC61000-4-5 (Lightning) 8A (8/20 $\mu\text{s}$ )
- RoHS Compliant

## Dimensions and Pin Configuration

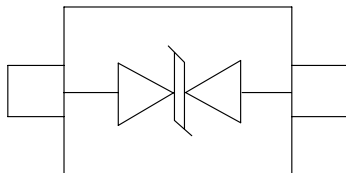

SOD-323

## Mechanical Characteristics

- Package: SOD-323
- Lead Finish: Matte Tin
- Case Material: "Green" Molding Compound.
- Terminal Connections: See Diagram Below
- Marking Information: See Below

## Applications

- Cellular Handsets and Accessories
- Personal Digital Assistants
- Notebooks and Handhelds
- Portable Instrumentation
- Peripherals
- Pagers Peripherals
- Desktop and Servers

## Marking Information

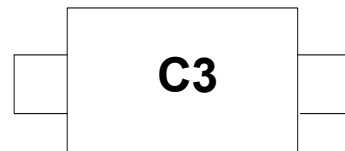

## Ordering Information

Part Number	Packaging	Reel Size
ASD30C-LS	3000/Tape & Reel	7 inch

**Absolute Maximum Ratings ( $T_A=25^{\circ}\text{C}$  unless otherwise specified)**

Parameter	Symbol	Value	Unit
Peak Pulse Power (8/20 $\mu\text{s}$ )	Ppk	500	W
Peak Pulse Current (8/20 $\mu\text{s}$ )	I <sub>PP</sub>	8	A
ESD per IEC 61000-4-2 (Air) ESD per IEC 61000-4-2 (Contact)	V <sub>ESD</sub>	$\pm 30$ $\pm 30$	kV
Operating Temperature Range	T <sub>J</sub>	-55 to +125	$^{\circ}\text{C}$
Storage Temperature Range	T <sub>stg</sub>	-55 to +150	$^{\circ}\text{C}$

**Electrical Characteristics ( $T_A=25^{\circ}\text{C}$  unless otherwise specified)**

Parameter	Symbol	Min	Typ	Max	Unit	Test Condition
Reverse Working Voltage	V <sub>RWM</sub>			30	V	
Breakdown Voltage	V <sub>BR</sub>	35			V	I <sub>T</sub> = 1mA
Reverse Leakage Current	I <sub>R</sub>			0.5	$\mu\text{A}$	V <sub>RWM</sub> = 30V
Clamping Voltage	V <sub>C</sub>			37	V	I <sub>PP</sub> = 1A (8 x 20 $\mu\text{s}$ pulse)
Clamping Voltage	V <sub>C</sub>			63	V	I <sub>PP</sub> = 8A (8 x 20 $\mu\text{s}$ pulse)
Junction Capacitance	C <sub>J</sub>		15	20	pF	V <sub>R</sub> = 0V, f = 1MHz

**Typical Performance Characteristics ( $T_A=25^\circ\text{C}$  unless otherwise Specified)**

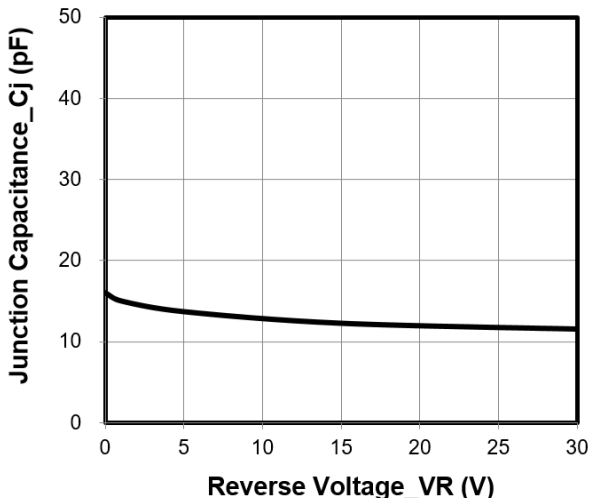

**Junction Capacitance vs. Reverse Voltage**

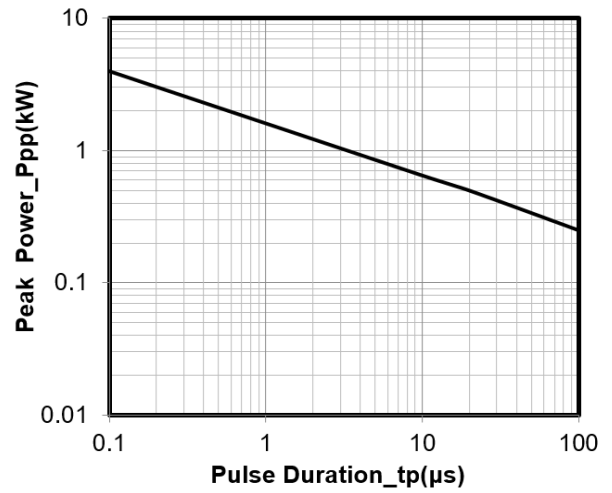

**Peak Pulse Power vs. Pulse Time**

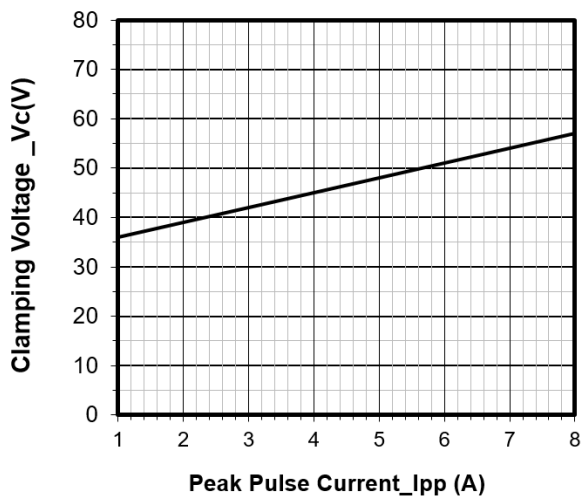

**Clamping Voltage vs. Peak Pulse Current**

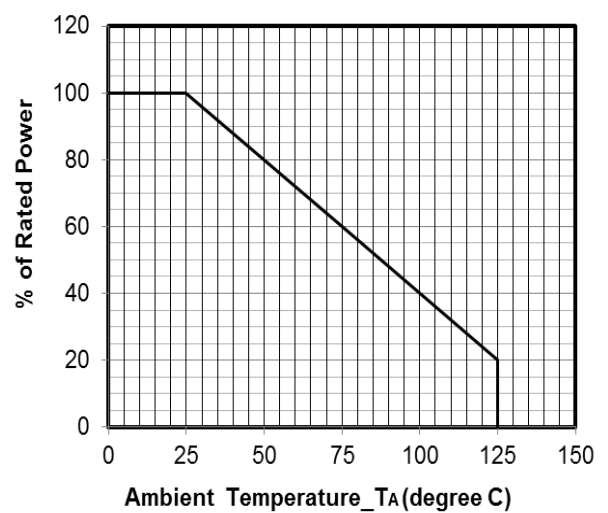

**Power Derating Curve**

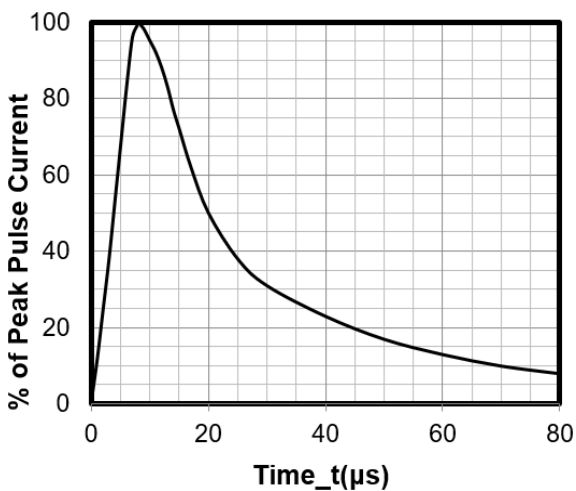

**8 X 20μs Pulse Waveform**

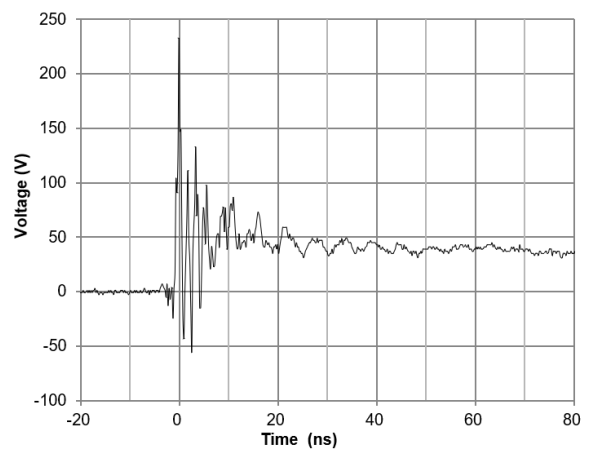

**ESD Clamping Voltage  
8 kV Contact per IEC61000-4-2**

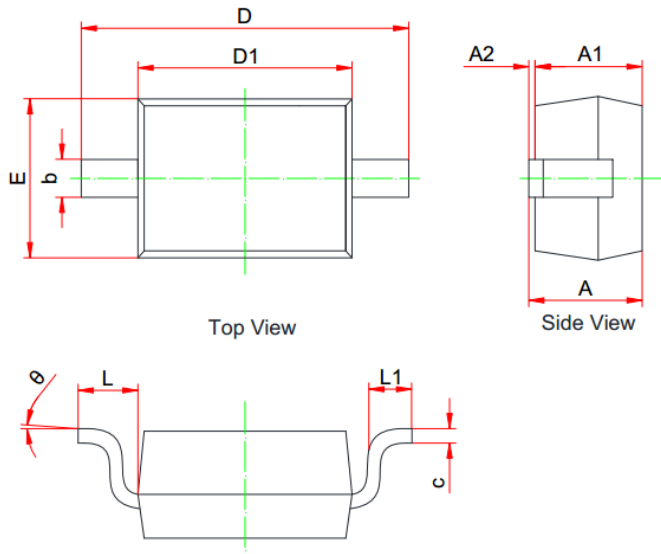
**SOD-323 Package Outline Drawing**

SYM	MILLIMETERS		
	MIN	NOM	MAX
A	0.800	--	1.100
A1	0.800	--	0.900
A2	0.000	--	0.100
b	0.250	--	0.400
c	0.080	--	0.177
D1	1.600	1.700	1.800
D	2.300	--	2.800
E	1.150	--	1.400
L	0.475REF		
L1	0.100	--	0.500
$\theta$	0°	--	8°

**Suggested Land Pattern**

**Unit: mm**
**Contact Information**

Applied Power Microelectronics Inc.

 Website: <http://www.appliedpowermicro.com>

 Email: [sales@appliedpowermicro.com](mailto:sales@appliedpowermicro.com)

Phone: +86 (0519) 8399 3606