

### Description

The ASD1225 is designed for asymmetrical (12V to – 25V) protection in multi-point data transmission application, making this device an ideal solution for protecting voltage sensitive high-speed data lines. The ASD1225 complies with the IEC 61000-4-2 (ESD) with  $\pm 30\text{kV}$  air and  $\pm 30\text{kV}$  contact discharge. It is assembled into a lead-free SOD-323 package. The small size, low capacitance and high ESD surge protection make ASD1225 an ideal choice to protect one data line of the Local information Network (LIN) in an automotive

### Features

- 280W peak pulse power (8/20 $\mu\text{s}$ )
- Low Channel input capacitance
- Ultra low leakage: nA level
- Low clamping voltage
- Protects one data line of the LIN
- Complies with following standards:
  - IEC 61000-4-2 (ESD) immunity test
    - Air discharge:  $\pm 30\text{kV}$
    - Contact discharge:  $\pm 30\text{kV}$
- RoHS Compliant

### Mechanical Characteristics

- Package: SOD-323
- Lead Finish: Matte Tin
- Case Material: “Green” Molding Compound.
- Terminal Connections: See Diagram Below
- Marking Information: See Below

### Applications

- Cellular Handsets and Accessories
- Personal Digital Assistants
- Notebooks and Handhelds
- Portable Instrumentation
- Peripherals
- Pagers Peripherals

### Marking Information



### Dimensions and Pin Configuration

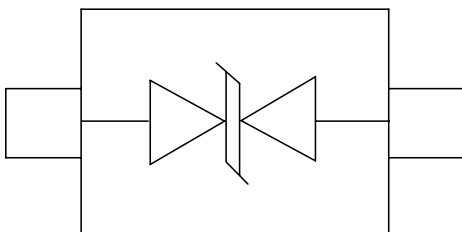

Circuit and Pin Schematic

### Ordering Information

Part Number	Packaging	Reel Size
ASD1225	3000/Tape & Reel	7 inch

**Absolute Maximum Ratings (T<sub>A</sub>=25°C unless otherwise specified)**

Parameter	Symbol	Value	Unit
Peak Pulse Power (8/20μs)	Ppk	280	W
Peak Pulse Current (tp = 8/20μs), Pin 1 to Pin 2	Ipp	12.5	A
Peak Pulse Current (tp = 8/20μs), Pin 2 to Pin 1		6	
ESD per IEC 61000-4-2 (Air)	VESD	±30	kV
ESD per IEC 61000-4-2 (Contact)		±30	
Operating Temperature Range	TJ	-40 to +85	°C
Storage Temperature Range	Tstg	-55 to +150	°C

**Electrical Characteristics (T<sub>A</sub>=25°C unless otherwise specified)**

Parameter	Symbol	Pin 1 to 2 (12V TVS)			Pin 2 to 1 (25V TVS)			Unit	Test Condition
		Min	Typ	Max	Min	Typ	Max		
Reverse Working Voltage	VRWM			12			25	V	
Breakdown Voltage	VBR	14			28			V	IT = 1mA
Reverse Leakage Current	IR			50			50	nA	VR = VRWM
Clamping Voltage	VC			16			32	V	I <sub>PP</sub> = 1A (8 x 20μs pulse)
Clamping Voltage	VC						45	V	I <sub>PP</sub> = 6A (8 x 20μs pulse)
Clamping Voltage	VC			23				V	I <sub>PP</sub> = 12.5A (8 x 20μs pulse)
Junction Capacitance	CJ		21			21		pF	VR = 0V, f = 1MHz
Junction Capacitance	CJ		14			8		pF	VR = VRWM, f = 1MHz

**Typical Performance Characteristics (TA=25°C unless otherwise Specified)**

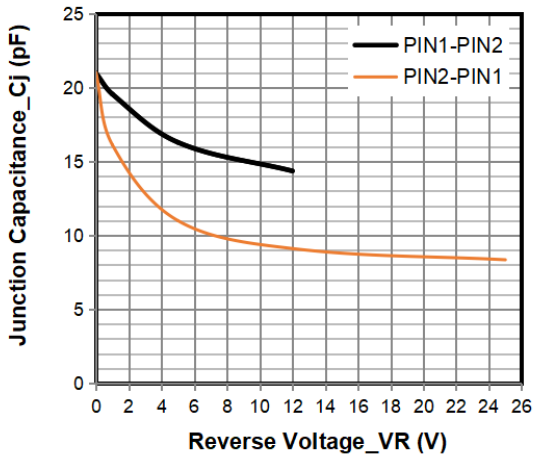

**Junction Capacitance vs. Reverse Voltage**

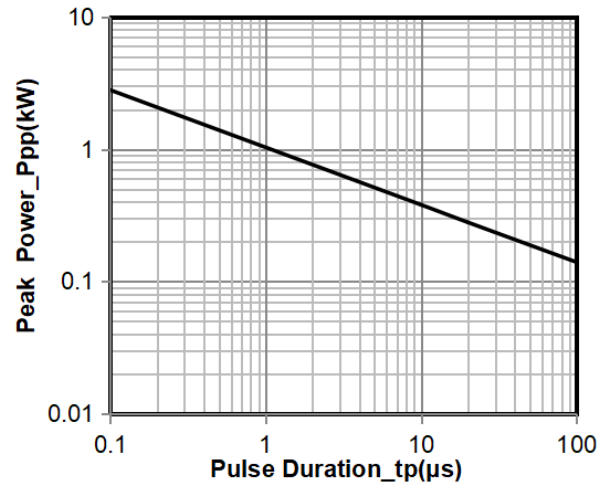

**Peak Pulse Power vs. Pulse Time**

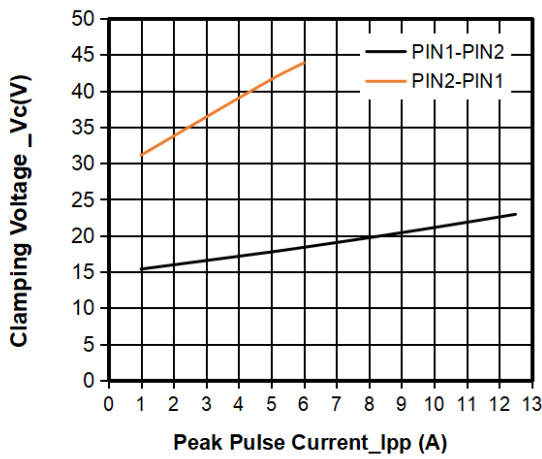

**Clamping Voltage vs. Peak Pulse Current**

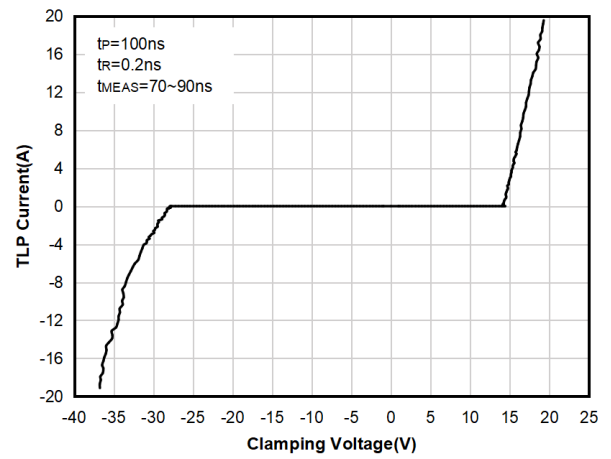

**TLP Curve**

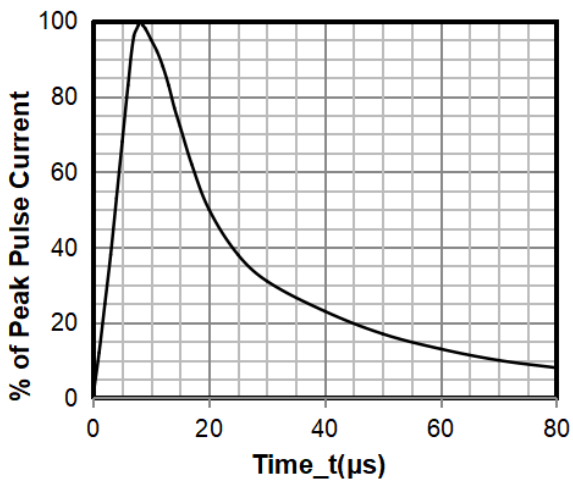

**8 X 20μs Pulse Waveform**

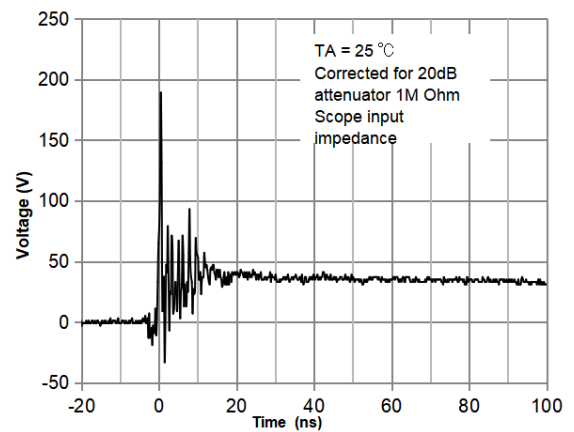

**Note: Data is taken with a 10x attenuator**

**ESD Clamping Voltage  
8 kV Contact per IEC61000-4-2**

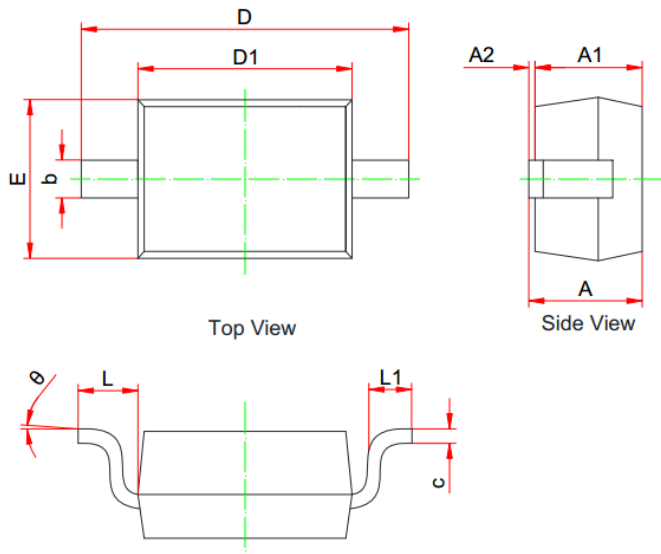
**SOD-323 Package Outline Drawing**

SYM	MILLIMETERS		
	MIN	NOM	MAX
A	0.800	--	1.100
A1	0.800	--	0.900
A2	0.000	--	0.100
b	0.250	--	0.400
c	0.080	--	0.177
D1	1.600	1.700	1.800
D	2.300	--	2.800
E	1.150	--	1.400
L	0.475REF		
L1	0.100	--	0.500
Θ	0°	--	8°

**Suggested Land Pattern**

**Unit: mm**
**Contact Information**

Applied Power Microelectronics Inc.

 Website: <http://www.appliedpowermicro.com>

 Email: [sales@appliedpowermicro.com](mailto:sales@appliedpowermicro.com)

Phone: +86 (0519) 8399 3606

Applied Power Microelectronics Inc. (APM) reserves the right to make changes to the product specification and data in this document without notice. APM makes no warranty, representation or guarantee regarding the suitability of its products for any particular purpose, nor does APM assume any liability arising from the application or use of any products or circuits, and specifically disclaims any and all liability, including without limitation special, consequential or incidental damages.