

### Description

The AR1511D3 is a 15V bi-directional TVS diode, utilizing leading monolithic silicon technology to provide fast response time and low ESD clamping voltage, making this device an ideal solution for protecting voltage sensitive high-speed data lines. The AR1511D3 has a low capacitance with a typical value at 1pF, and complies with the IEC 61000-4-2 (ESD) with  $\pm 25\text{kV}$  air and  $\pm 20\text{kV}$  contact discharge. It is assembled into a lead-free SOD-323 package. The small size, low capacitance and high ESD surge protection make AR1511D3 an ideal choice to protect cell phone, wireless systems, and communication equipment.

### Features

- 300W peak pulse power (8/20 $\mu\text{s}$ )
- Ultra low capacitance: 1pF typical
- Ultra low leakage: nA level
- Operating voltage: 15V
- Low clamping voltage
- Protects one power line or data line
- Complies with following standards:
  - IEC 61000-4-2 (ESD) immunity test  
 Air discharge:  $\pm 25\text{kV}$   
 Contact discharge:  $\pm 20\text{kV}$
  - IEC61000-4-5 (Lightning) 8A (8/20 $\mu\text{s}$ )
- RoHS Compliant

### Mechanical Characteristics

- Package: SOD-323
- Lead Finish: Matte Tin
- Case Material: “Green” Molding Compound.
- Terminal Connections: See Diagram Below
- Marking Information: See Below

### Applications

- USB Ports
- Smart Phones
- Wireless Systems
- Ethernet 10/100/1000 Base T

### Marking Information

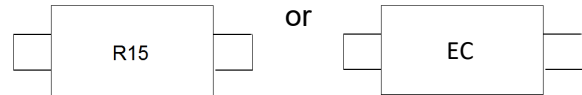

### Ordering Information

Part Number	Packaging	Reel Size
AR1511D3	3000/Tape & Reel	7 inch

### Dimensions and Pin Configuration

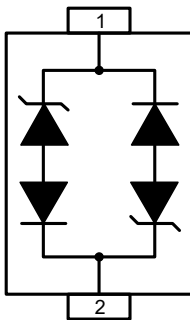

Circuit and Pin Schematic

**Absolute Maximum Ratings (T<sub>A</sub>=25°C unless otherwise specified)**

Parameter	Symbol	Value	Unit
Peak Pulse Power (8/20μs)	Ppk	240	W
Peak Pulse Current (8/20μs)	I <sub>PP</sub>	8	A
ESD per IEC 61000-4-2 (Air) ESD per IEC 61000-4-2 (Contact)	V <sub>ESD</sub>	±25 ±20	kV
Operating Temperature Range	T <sub>J</sub>	-40 to +85	°C
Storage Temperature Range	T <sub>stg</sub>	-55 to +150	°C

**Electrical Characteristics (T<sub>A</sub>=25°C unless otherwise specified)**

Parameter	Symbol	Min	Typ	Max	Unit	Test Condition
Reverse Working Voltage	V <sub>RWM</sub>			15	V	
Breakdown Voltage	V <sub>BR</sub>	16.7			V	I <sub>T</sub> = 1mA
Reverse Leakage Current	I <sub>R</sub>			0.2	μA	V <sub>RWM</sub> = 15V
Clamping Voltage	V <sub>C</sub>			21	V	I <sub>PP</sub> = 1A (8 x 20μs pulse)
Clamping Voltage	V <sub>C</sub>			30	V	I <sub>PP</sub> = 8A (8 x 20μs pulse)
Junction Capacitance	C <sub>J</sub>		1		pF	V <sub>R</sub> = 0V, f = 1MHz

**Typical Performance Characteristics (TA=25°C unless otherwise Specified)**

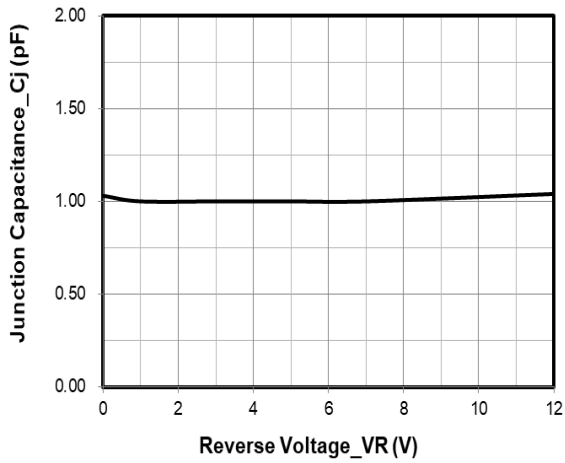

**Junction Capacitance vs. Reverse Voltage**

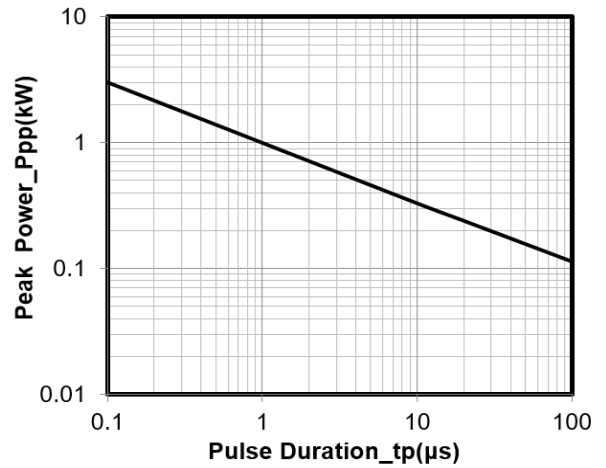

**Peak Pulse Power vs. Pulse Time**

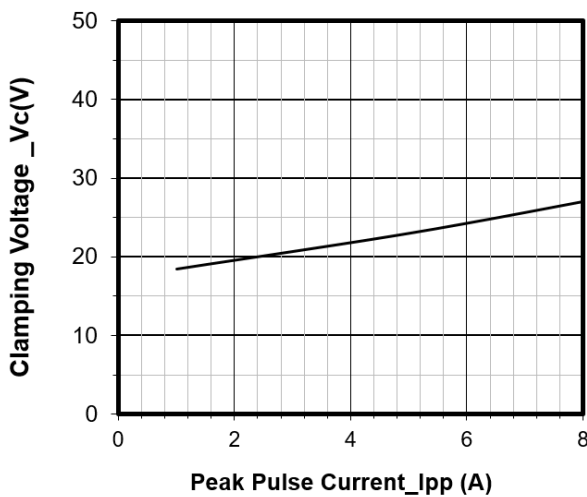

**Clamping Voltage vs. Peak Pulse Current**

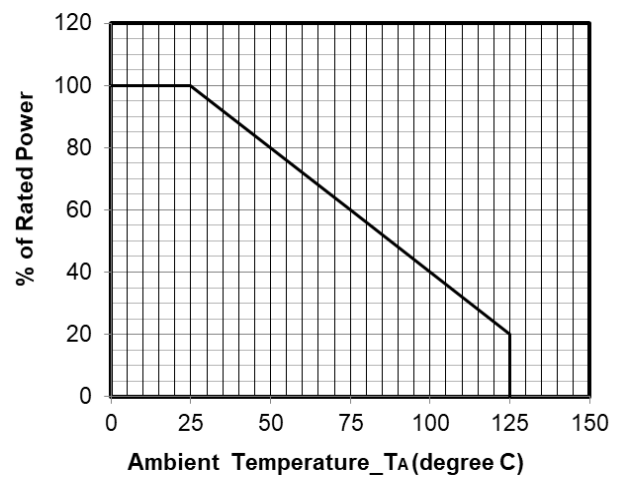

**Power Derating Curve**

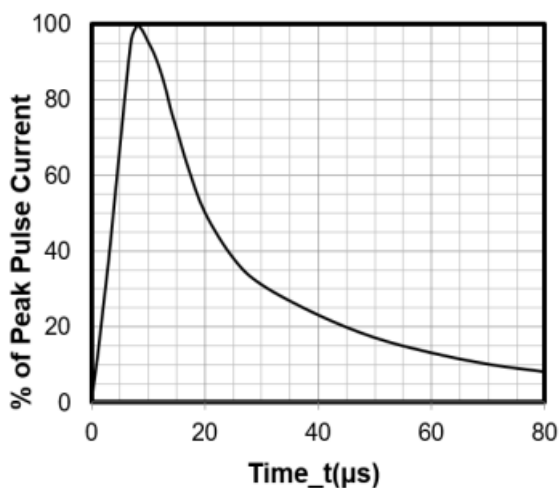

**8 X 20μs Pulse Waveform**

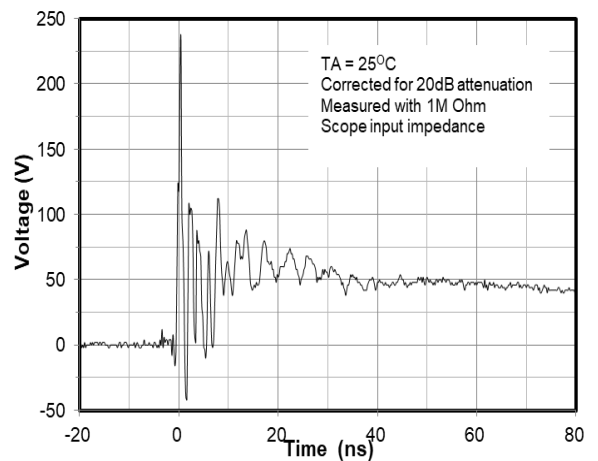

**ESD Clamping Voltage**  
**8 kV Contact per IEC61000-4-2**

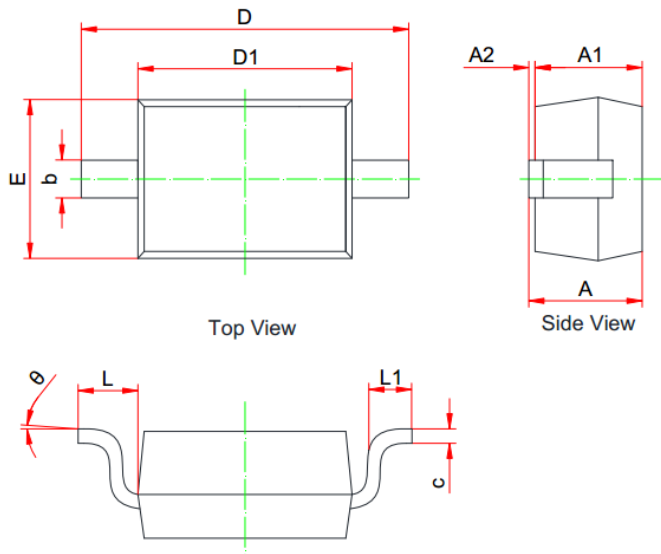
**SOD-323 Package Outline Drawing**

	MILLIMETERS		
	MIN	NOM	MAX
A	0.800	--	1.100
A1	0.800	--	0.900
A2	0.000	--	0.100
b	0.250	--	0.400
c	0.080	--	0.177
D1	1.600	1.700	1.800
D	2.300	--	2.800
E	1.150	--	1.400
L	0.475REF		
L1	0.100	--	0.500
Θ	0°	--	8°

**Suggested Land Pattern**

**Unit: mm**
**Contact Information**

Applied Power Microelectronics Inc.

 Website: <http://www.appliedpowermicro.com>

 Email: [sales@appliedpowermicro.com](mailto:sales@appliedpowermicro.com)

Phone: +86 (0519) 8399 3606

Applied Power Microelectronics Inc. (APM) reserves the right to make changes to the product specification and data in this document without notice. APM makes no warranty, representation or guarantee regarding the suitability of its products for any particular purpose, nor does APM assume any liability arising from the application or use of any products or circuits, and specifically disclaims any and all liability, including without limitation special, consequential or incidental damages.