

Description

The AR0711P0LV is a bi-directional TVS diode, utilizing leading monolithic silicon technology to provide fast response time and low ESD clamping voltage, making this device an ideal solution for protecting voltage sensitive high-speed data lines. The AR0711P0LV has an ultra-low capacitance with a typical value at 0.2pF, and complies with the IEC 61000-4-2 (ESD) standard with $\pm 25\text{kV}$ air and $\pm 20\text{kV}$ contact discharge. It is assembled into an ultra-small 0.6x0.3x0.3mm lead-free DFN package. The small size, ultra-low capacitance and high ESD surge protection make AR0711P0LV an ideal choice to protect cell phone, digital video interfaces, HDMI, DVI, USB2.0, USB3.0, and other high speed ports.

Features

- Ultra small package: 0.6x0.3x0.3mm
- Ultra low capacitance: 0.2pF typical
- Ultra low leakage: nA level
- Operating voltage: up to 7V
- Low clamping voltage
- Complies with following standards:
 - IEC 61000-4-2 (ESD) immunity test
 - Air discharge: $\pm 25\text{kV}$
 - Contact discharge: $\pm 20\text{kV}$
 - IEC61000-4-5 (Lightning) 2.5A (8/20 μs)
- RoHS Compliant

Dimensions and Pin Configuration

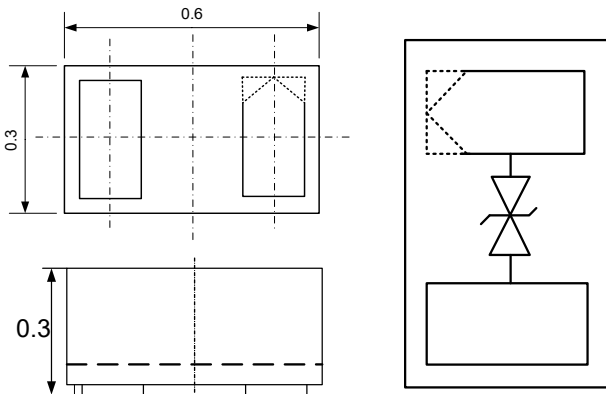

Package Dimensions

Circuit and Pin Schematic

Mechanical Characteristics

- Package: DFN0603-2 (0.6x0.3x0.3mm)
- Case Material: “Green” Molding Compound.
- Terminal Connections: See Diagram Below
- Marking Information: See Below

Applications

- Cellular Handsets and Accessories
- Display Ports
- MDDI Ports
- USB Ports
- Digital Visual Interface (DVI)
- PCI Express and Serial SATA Ports

Marking Information



Ordering Information

Part Number	Packaging	Reel Size
AR0711P0LV	10000/Tape & Reel	7 inch

Absolute Maximum Ratings (T_A=25°C unless otherwise specified)

Parameter	Symbol	Value	Unit
Peak Pulse Power (8/20μs)	P _{pk}	37.5	W
Peak Pulse Current (8/20μs)	I _{PP}	2.5	A
ESD per IEC 61000-4-2 (Air) ESD per IEC 61000-4-2 (Contact)	V _{ESD}	±25 ±20	kV
Operating Temperature Range	T _J	-55 to +125	°C
Storage Temperature Range	T _{stg}	-55 to +150	°C

Electrical Characteristics (T_A=25°C unless otherwise specified)

Parameter	Symbol	Min	Typ	Max	Unit	Test Condition
Reverse Working Voltage	V _{RWM}			7	V	
Breakdown Voltage	V _{BR}	8.5			V	I _T = 1mA
Reverse Leakage Current	I _R			0.2	μA	V _{RWM} = 7V
Clamping Voltage	V _C		10.5	13	V	I _{PP} = 1A (8 x 20μs pulse)
Clamping Voltage	V _C		13	15	V	I _{PP} = 2.5A (8 x 20μs pulse)
Junction Capacitance	C _J		0.2	0.4	pF	V _R = 0V, f = 1MHz
Junction Capacitance	C _J		0.15	0.3	pF	V _R = 0V, f = 3GHz

Typical Performance Characteristics ($T_A=25^\circ\text{C}$ unless otherwise Specified)

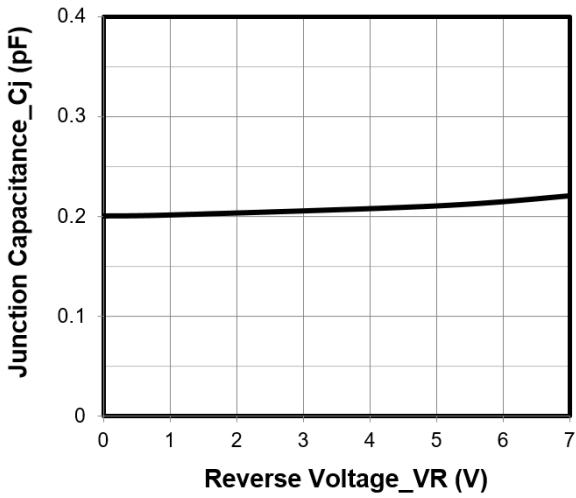

Junction Capacitance vs. Reverse Voltage

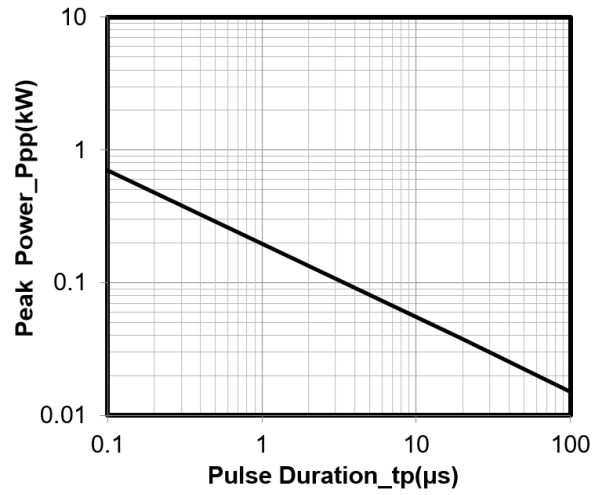

Peak Pulse Power vs. Pulse Time

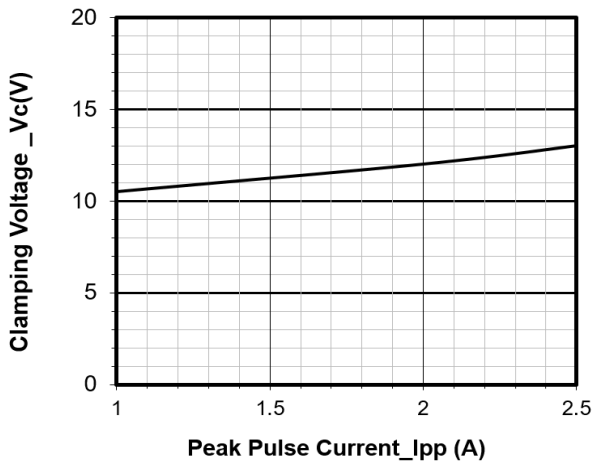

Clamping Voltage vs. Peak Pulse Current

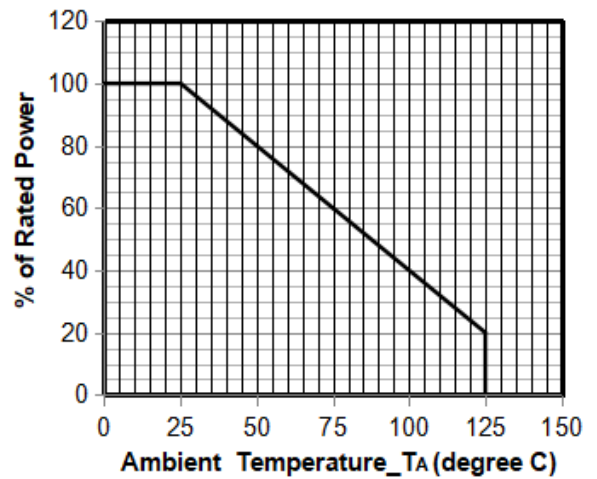

Power Derating Curve

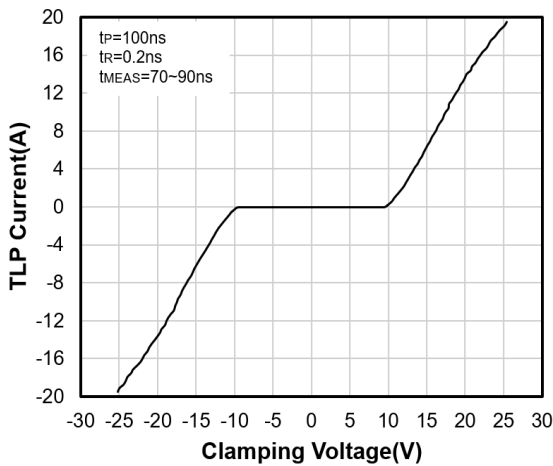

Transmission Line Pulse (TLP) Measurement

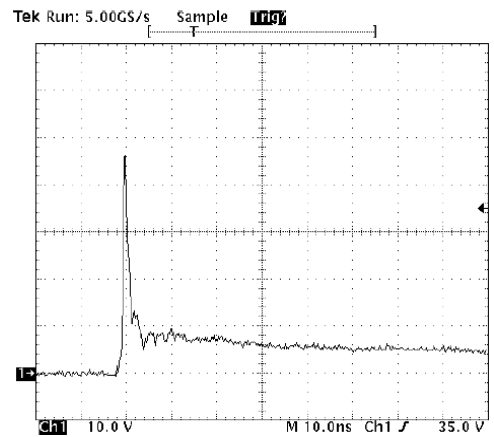

ESD Clamping Voltage

8 kV Contact per IEC61000-4-2

DFN0603-2 Package Outline Drawing

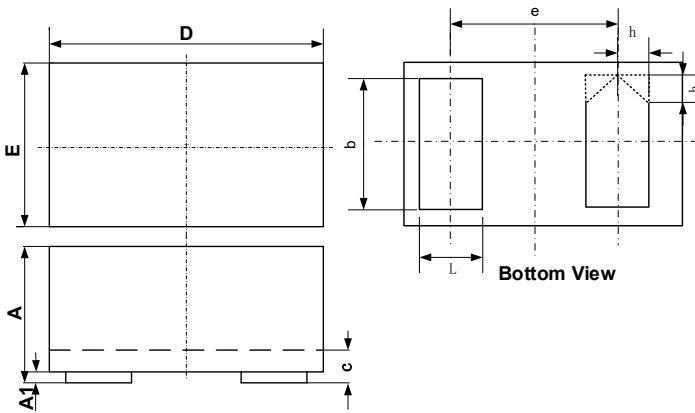

SYM	DIMENSIONS		
	MILLIMETERS		
	MIN	NOM	MAX
A	0.230		0.330
A1	0.000	0.020	0.050
b	0.215	0.245	0.275
c	0.120	0.150	0.180
D	0.550	0.600	0.650
e	0.355 BSC		
E	0.250	0.300	0.350
L	0.160	0.190	0.220
h	0.079 BSC		

Suggested Land Pattern

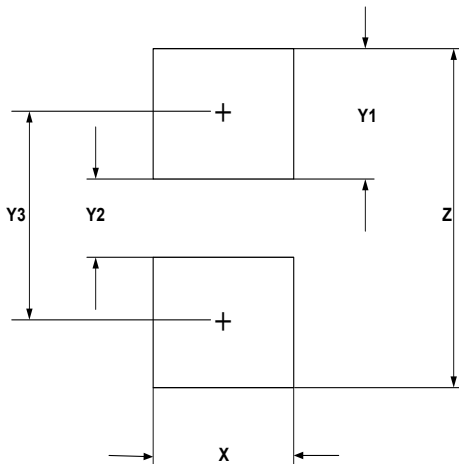

SYM	DIMENSIONS	
	MILLIMETERS	INCHES
X	0.30	0.012
Y1	0.25	0.010
Y2	0.15	0.006
Y3	0.40	0.016
Z	0.65	0.026

Contact Information

Applied Power Microelectronics Inc.

Website: <http://www.appliedpowermicro.com>

Email: sales@appliedpowermicro.com

Phone: +86 (0519) 8399 3606