

Description

The AR0504S5 is a low capacitance TVS array, utilizing leading monolithic silicon technology to provide fast response time and low ESD clamping voltage, making this device an ideal solution for protecting voltage sensitive high-speed data lines. The AR0504S5 has low capacitance with a typical value at 0.5pF, and complies with the IEC 61000-4-2 (ESD) standard with $\pm 15\text{kV}$ air and $\pm 8\text{kV}$ contact discharge. It is assembled into a 5-pin lead-free SOT-553 package. The combination of small size, low capacitance and high level of ESD protection makes it ideal for cellular, notebooks, desktops, and other portable application.

Features

- Ultra low leakage: nA level
- Low operating voltage: 5V
- Low clamping voltage
- Up to 4 lines protects
- JEDEC SOT-553 package
- Complies with following standards:
 - IEC 61000-4-2 (ESD) immunity test
 - Air discharge: $\pm 15\text{kV}$
 - Contact discharge: $\pm 8\text{kV}$
- RoHS Compliant

Mechanical Characteristics

- Package: SOT-553
- Lead Finish: Matte Tin
- Case Material: “Green” Molding Compound.
- Terminal Connections: See Diagram Below
- Marking Information: See Below

Applications

- Cellular Handsets and Accessories
- Personal Digital Assistants
- Notebooks and Handhelds
- Portable Instrumentation
- Digital Cameras
- Peripherals
- Audio Players
- Keypads, Side Keys, LCD Displays

Marking Information

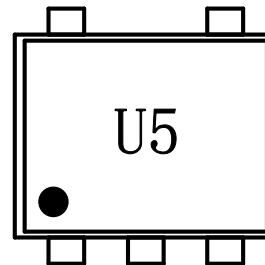

Dot indicates pin1
 U5 = device marking code

Ordering Information

Part Number	Packaging	Reel Size
AR0504S5	3000/Tape & Reel	7 inch

Dimensions and Pin Configuration

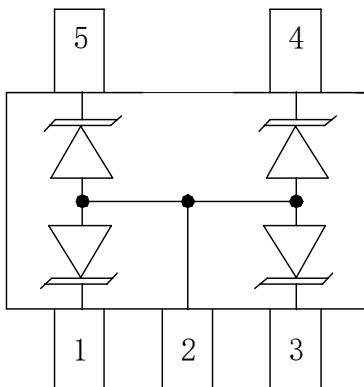

Circuit and Pin Schematic

Absolute Maximum Ratings ($T_A=25^\circ\text{C}$ unless otherwise specified)

Parameter	Symbol	Value	Unit
Peak Pulse Power (8/20 μs)	Ppk	25	W
Peak Pulse Current (8/20 μs)	I _{PP}	2	A
ESD per IEC 61000-4-2 (Air) ESD per IEC 61000-4-2 (Contact)	V _{ESD}	± 15 ± 8	kV
Operating Temperature Range	T _J	-55 to +125	$^\circ\text{C}$
Storage Temperature Range	T _{stg}	-55 to +150	$^\circ\text{C}$

Electrical Characteristics ($T_A=25^\circ\text{C}$ unless otherwise specified)

Parameter	Symbol	Min	Typ	Max	Unit	Test Condition
Reverse Working Voltage	V _{RWM}			5	V	
Breakdown Voltage	V _{BR}	6			V	I _T = 1mA, any I/O to pin 2
Reverse Leakage Current	I _R			0.1	μA	V _{RWM} = 5V
Clamping Voltage	V _C			10.5	V	I _{PP} = 1A (8 x 20 μs pulse)
Clamping Voltage	V _C			12.5	V	I _{PP} = 2A (8 x 20 μs pulse)
Junction Capacitance	C _J		0.3		pF	V _R = 0V, f = 1MHz, between I/O pins
Junction Capacitance	C _J		0.5		pF	V _R = 0V, f = 1MHz, any I/O to pin 2

Note 1: I/O pins are Pin 1, 3, 4 and 5

Typical Performance Characteristics ($T_A=25^\circ\text{C}$ unless otherwise Specified)

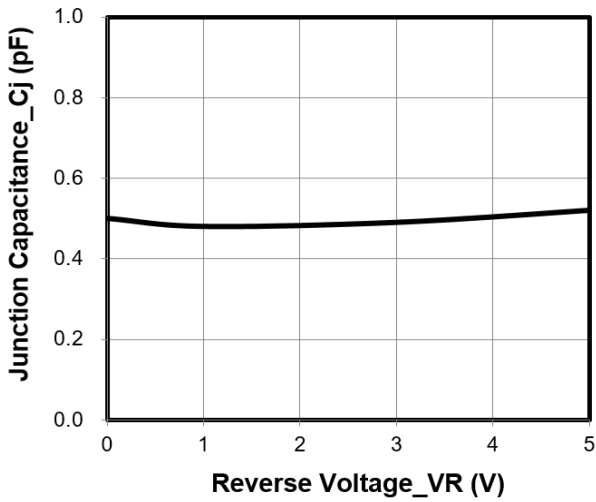

Junction Capacitance vs. Reverse Voltage

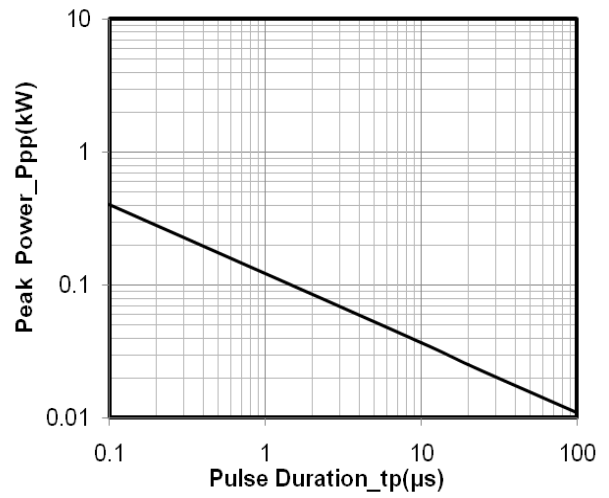

Peak Pulse Power vs. Pulse Time

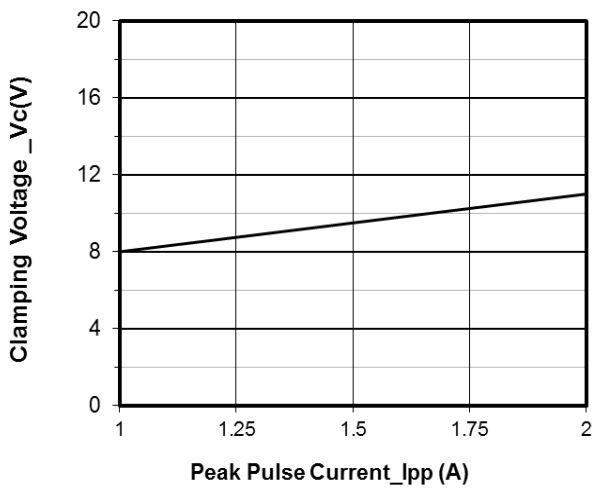

Clamping Voltage vs. Peak Pulse Current ($t_p = 8/20\mu\text{s}$)

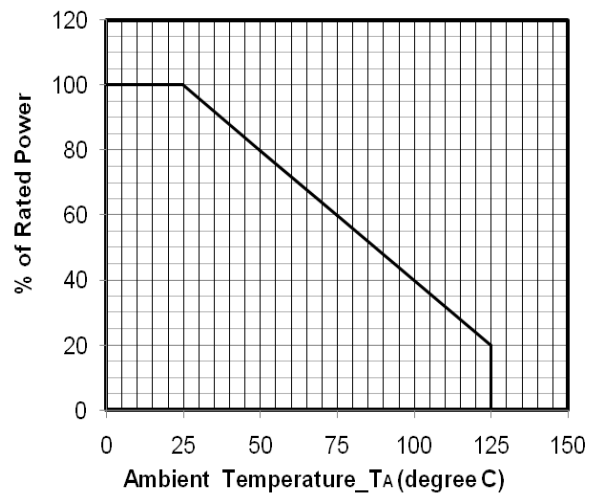

Power Derating Curve

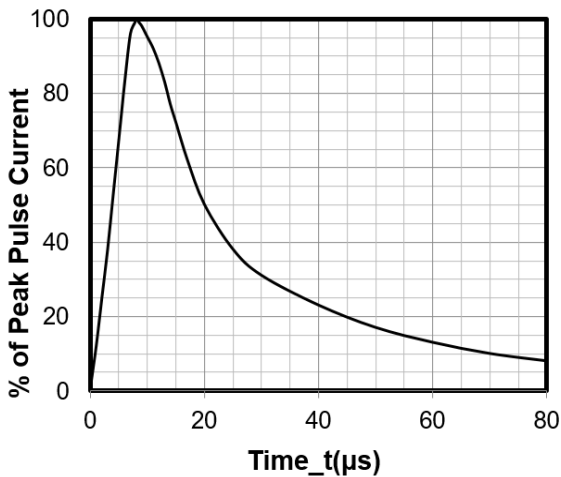

8 X 20μs Pulse Waveform

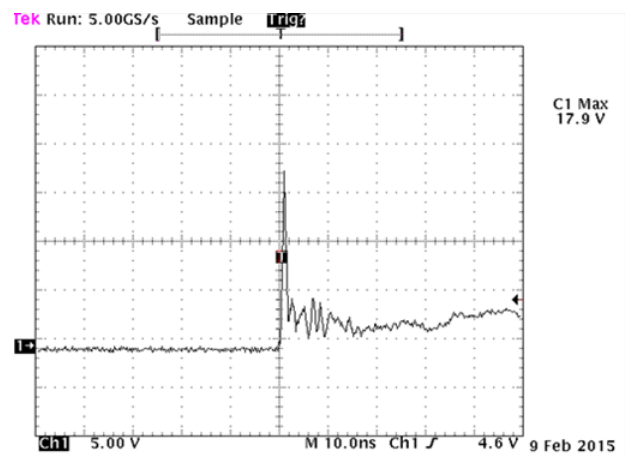

Note: Data is taken with a 10x attenuator

ESD Clamping Voltage

+8 kV Contact per IEC61000-4-2

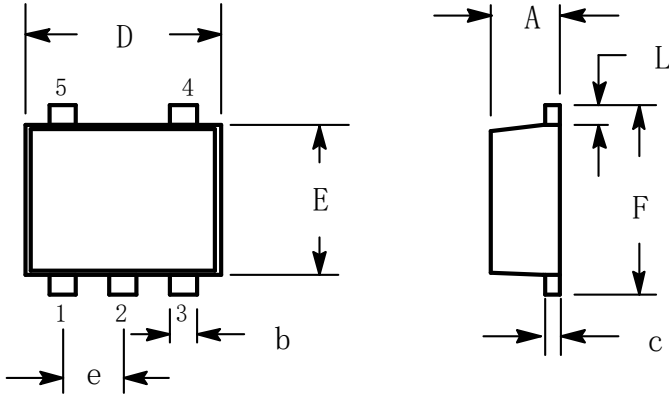
SOT-553 Package Outline Drawing

DIM	DIMENSIONS					
	MILLIMETERS			INCHES		
	MIN	NOM	MAX	MIN	NOM	MAX
A	0.50	0.55	0.60	0.020	0.022	0.024
b	0.17	0.22	0.27	0.007	0.009	0.011
c	0.08	0.13	0.18	0.003	0.005	0.007
D	1.50	1.60	1.70	0.059	0.063	0.067
e	0.50 BSC			0.020 BSC		
E	1.10	1.20	1.30	0.043	0.047	0.051
L	0.10	0.20	0.30	0.004	0.008	0.012
F	1.50	1.60	1.70	0.059	0.063	0.067

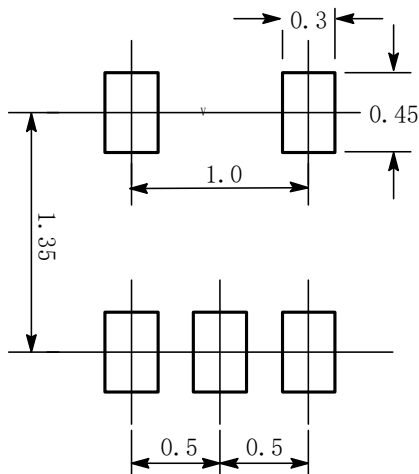
Suggested Land Pattern

NOTE: CONTROLLING DIMENSION: MILLIMETERS

Contact Information

Applied Power Microelectronics Inc.
 Website: <http://www.appliedpowermicro.com>
 Email: sales@appliedpowermicro.com
 Phone: +86 (0519) 8399 3606