

000Z100001dL

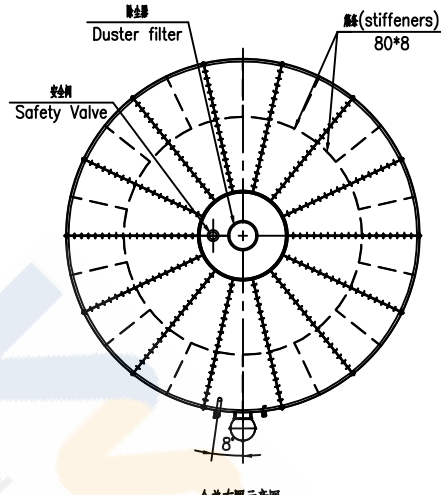

Layout of silo cover

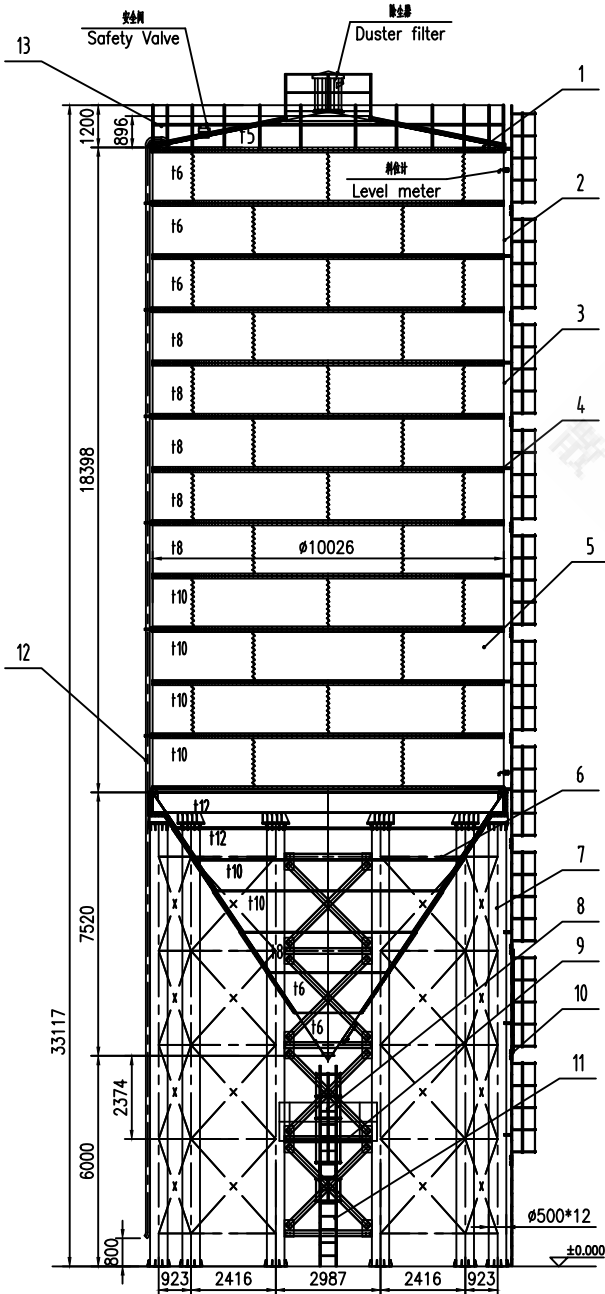
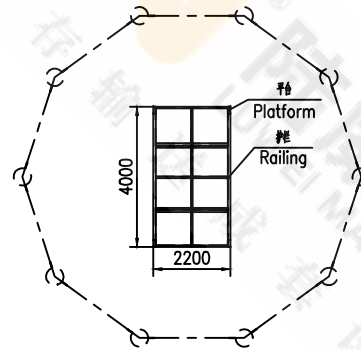

Layout of platform

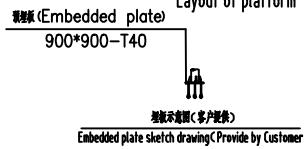

Embedded plate sketch drawing (Provide by Customer)

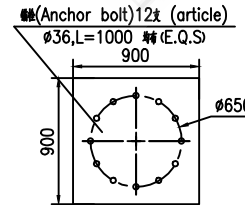

foundation (Provide by Customer)

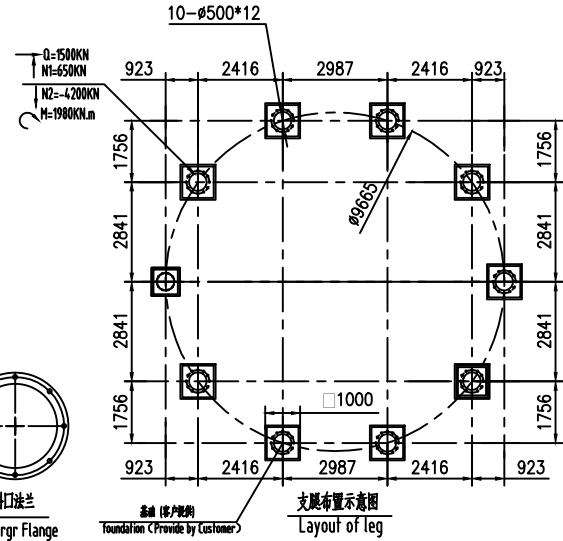

Layout of leg

技术参数 (Technical Parameter):

- 筒仓容量2125T, 扣除500高料位装载2074T, 装载效率97.6%, 密度按1.3t/m<sup>3</sup>计; (Capacity 2125T, Actual Capacity 2074T, Volume Ratio 97.6%, Density 1.3t/m<sup>3</sup>);
- 底漆: 铁红环氧防锈底漆, 面漆: 丙烯酸面漆, 颜色业主定; (Primer: Iron red epoxy antirust primer, Finish paint: pioner topcoat, Customer specified color.)
- 使用条件: 压力<5KPa, 风压: 0.8KN/m<sup>2</sup>. (Use conditions: Pressure < 5KPa, Wind pressure: 0.8KN/m<sup>2</sup>.)

序号 NO.	代号 CODE	名称/NAME	数量 Q.T.Y	材料 MATERIAL	单位 S-WEIGHT	重量 WEIGHT	备注 MARK
13	TP10000T2000.13	顶护栏(Silo top railing)	1	Q235B			
12	TP10000T2000.12	进灰管(Feed pipe)	1	Q235B			
11	TP10000T2000.11	平台爬梯(Platform Straight ladder)	1	Q235B			
10	TP10000T2000.10	仓顶爬梯(Top Straight ladder)	1	Q235B			
9	TP10000T2000.9	平台(Platform railing)	1	Q235B			
8	TP10000T2000.8	平台扶手(Platform railing)	1	Q235B			
7	TP10000T2000.7	支腿架(Leg assembly drawing)	1	Q235B			
6	TP10000T2000.6	锥体(Cone)	1	Q235B			
5	TP10000T2000.5	仓板3(Silo body plate 3)	24	Q235B			
4	TP10000T2000.4	T型法兰(T type steel flange)	11	Q235B			
3	TP10000T2000.3	仓板2(Silo body plate 2)	30	Q235B			
2	TP10000T2000.2	仓板1(Silo body plate 1)	18	Q235B			
1	TP10000T2000.1	仓盖(Silo cover)	1	Q235B			

方案图

厦门陆威工程机械有限公司  
Xiamen Luwei Construction Equipment Co., Ltd.

TPØ10000-2000T-H6000

TP10000T2000

比例/Scale 1:100

总页数/Total Pages 页 Pages 页

Autodesk

借通用件登记  
描图  
校核  
回底图总号  
签字  
日期

Autodesk  
A  
B  
C  
E  
F  
G  
H