

TP3800T150.00

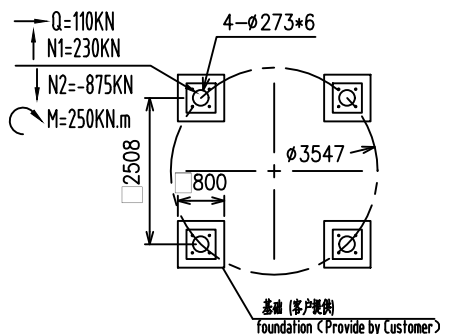
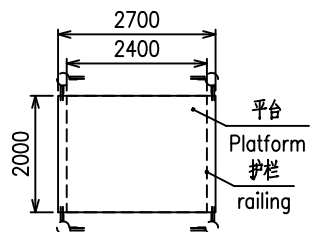
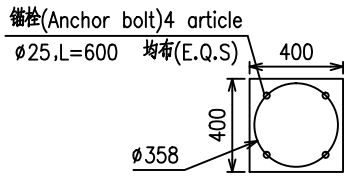
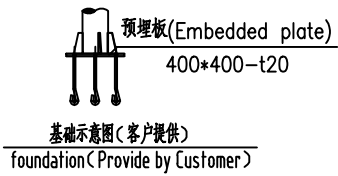
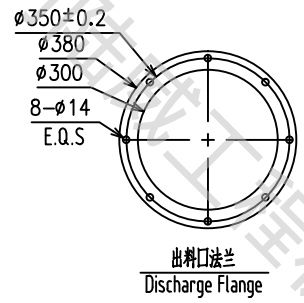
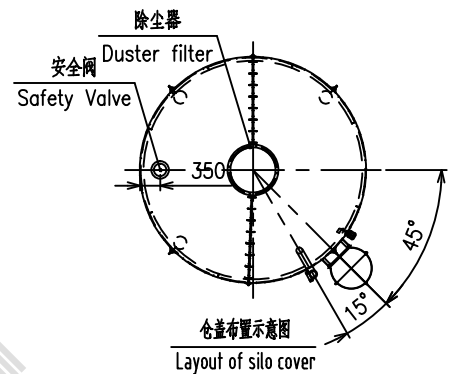
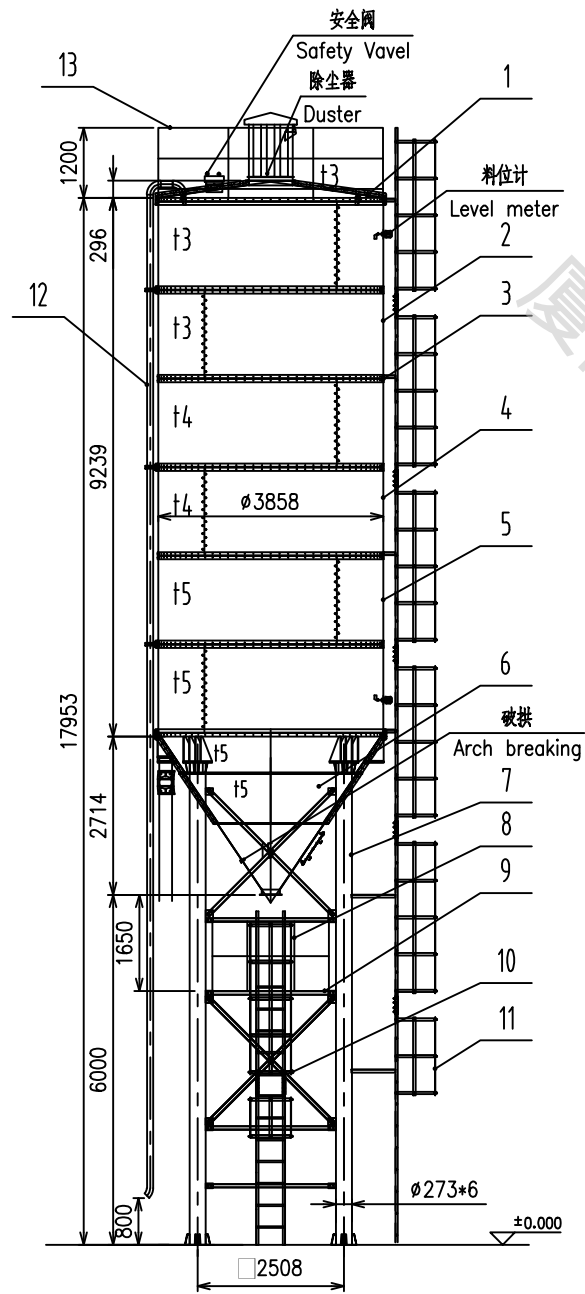

技术参数 (Technical Parameter):

- 筒仓容量155T, 扣除500高料位装载147T, 装载效率95.1%, 密度按1.3t/m³计; (Capacity 155T, Actual Capacity 147T, Volume Ratio 95.1%, Density 1.3t/m³);
- 底漆: 铁红环氧防锈底漆, 面漆: 丙烯酸面漆, 颜色业主定; (Primer: Iron red epoxy antirust primer, Finish paint: pioner topcoat, Customer specified color.);
- 使用条件: 压力<5KPa, 风压: 0.8KN/m². (Use conditions: Pressure < 5KPa, Wind pressure: 0.8KN/m².)

13	TP3800T150.13	顶护栏(Silo top railing)	1	Q235B				
12	TP3800T150.12	进灰管(Feed pipe)	1	Q235B				
11	TP3800T150.11	仓顶爬梯(Top Straight ladder)	1	Q235B				
10	TP3800T150.10	平台爬梯(Platform Straight ladder)	1	Q235B				
9	TP3800T150.09	平台(Platform)	1	Q235B				
8	TP3800T150.08	平台护栏(Platform railing)	1	Q235B				
7	TP3800T150.07	支腿架(Leg assembly drawing)	1	Q235B				
6	TP3800T150.06	锥体(cone)	1	Q235B				
5	TP3800T150.05	仓板3(Silo body plate 3)	6	Q235B				
4	TP3800T150.04	仓板2(Silo body plate 2)	6	Q235B				
3	TP3800T150.03	T钢法兰(T type steel flange)	5	Q235B				
2	TP3800T150.02	仓板1(Silo body plate 1)	6	Q235B				
1	TP3800T150.01	仓盖(Silo cover)	1	Q235B				

序号 NO.	代号 CODE	名称/NAME	数量 Q.T.Y	材料 MATERIAL	单重 S-WEIGHT 重量 WEIGHT	总重 T-WEIGHT	备注 MARK
				Plan Drawing		厦门陆威工程机械有限公司 Xiamen Luwei Construction Equipment Co., Ltd.	
						TP3800T150.00	
				0		1:85	
				Total Pages共 页		Pages第 页	

Common part registration
Tracing
B Proofreading
Old drawing order
Sign
date