

Digital Audio Power Amplifier

Digital Audio Power Amplifier w/Dante



Installation and Operation Manual

V 1.1

Contents

Important Safety Instructions.....	II
Installation & User Guide.....	IV
Chapter 1 Overview.....	1
Chapter 2 Functions and indications	2
Chapter 3 Connection and operation.....	4
3.1 Input/Output	4
3.2 Connection	4
3.3 Operating instructions	5
3.3.1 Protect speaker	5
3.3.2 Matters need attention	5
3.4 Web control.....	7
Chapter 4 Specifications.....	13
Chapter 5 RS-232 control.....	14

Remark:

- All rights reserved for translation, reprint or reproduction
- Contents may change without prior announcement
- All technical specifications are guideline data and not guaranteed features
- TAIDEN Co., Ltd. is not responsible for any damage caused by improper use of this manual
- The equipment must be connected to earth!
- This product conforms to the rules of the European directive 2014/30/EU
- To protect your hearing, avoid high pressure level on earphones. Adjust to a lower and convenient level
- If any detailed information is needed, please contact your local agent or **TAIDEN** service center in your region.
Any feedback, advice and suggestion about the products is appreciated
- **TAIDEN** is the registered trademark of TAIDEN Co., Ltd.
- In order to extend the life time of the whole system, we strongly recommend that the congress system be scheduled to shut down every day in the evening when not in use

Important Safety Instructions

1. Read these instructions.
2. Keep these instructions.
3. Heed all warnings.
4. Follow all instructions.
5. The apparatus shall not be exposed to dripping or splashing and that no objects filled with liquids, such as vases, shall be placed on the apparatus.
6. The MAINS plug serving as a disconnection device, should be easy to operate.
7. The apparatus should be connected to the MAINS socket-outlet with protective earth.
8. Clean only with dry cloth.
9. Do not block any ventilation openings. Install in accordance with the manufacturer's instructions.
10. Do not install near any heat sources such as radiators, heat registers, stoves, or other apparatus (including amplifiers) that produce heat.
11. Do not defeat the safety purpose of the polarized or grounding-type plug. A polarized plug has two blades with one wider than the other. A grounding type plug has two blades and a third grounding prong. The wide blade and the third prong are provided for your safety. If the provided plug does not fit into your outlet, consult an electrician for replacement of the obsolete outlet.
12. Protect the power cord from being walked on or pinched particularly at plugs, convenience receptacles, and the point where they exit from the apparatus.
13. Only use attachments/accessories specified by the manufacturer.
14. Use only with the cart, stand, tripod, bracket, or table specified by the manufacturer, or sold with the apparatus. When a cart is used, use caution when moving the cart/apparatus combination to avoid injury from tip-over.
15. Unplug this apparatus during lightning storms or when unused for long periods of time.
16. Refer all servicing to qualified service personnel. Servicing is required when the apparatus has been damaged in any way, such as power-supply cord or plug is damaged, liquid has been spilled or objects have fallen into the apparatus, the apparatus has been exposed to rain or moisture, does not operate normally, or has been dropped.
17. Do not place the equipment on any uneven or unstable stand; original product package or appropriate package should be used to avoid damage caused by strong impacts during transportation.
18. Power supply cords: AC 100 V - 240 V 50/60 Hz
19. For service, please contact the nearest TAIDEN Service Center.
20. All TAIDEN products are guaranteed for definite time (see the WARRANTY CARD for details) excluding the following cases:
 - A. All damage or malfunction caused by human negligence;
 - B. Damage or malfunction caused by improper operating by operator;
 - C. Parts damage or loss caused by disassembling the product by non-authorized personnel.
21. Use ONLY specified connection cable to connect the system equipment.
22. Upon receipt of the product, please fill out the Warranty Card enclosed and post it to TAIDEN Service Center.



TO REDUCE THE RISK OF ELECTRIC SHOCK, DO NOT EXPOSE THIS EQUIPMENT TO RAIN OR MOISTURE.

CAUTION: To reduce the risk of electric shock, DO NOT open covers, no user serviceable parts inside. Refer servicing to qualified service personnel only.

CAUTION: DO NOT use alcohol, ammonia or petroleum solvents or abrasive cleaners to clean the devices.



The lightning flash with an arrowhead symbol, with an equilateral triangle, is intended to alert the user to the presence of uninsulated 'dangerous voltage' within the products enclosure that may be of sufficient magnitude to constitute a risk of electric shock to persons.

Important Safety Instructions



The exclamation mark within an equilateral triangle is intended to alert the user to the presence of important operating and maintenance (servicing) instructions in the literature accompanying the appliance.

WARNING: To reduce the risk of fire or electric shock, DO NOT expose units to rain or moisture.



Attention: Installation should be performed by qualified service personnel only in accordance with the National Electrical or applicable local codes.



Power Disconnect: Units with or without ON – OFF switch have power supplied to the unit whenever the power cord is inserted into the power source; however, the unit is operational only when the ON – OFF switch is in the ON position. The power cord is the main power disconnect for all units

WARNING: The apparatus should be connected to a mains socket outlet with a protective earthing connection.

Installation & User Guide

About this manual

This manual is a comprehensive guide to the installation and operation of the **TAIDEN** Digital Audio Power Amplifier (PA). It includes the detailed description of the functions and interfaces of the PA, including connection, installation, and operation.

The manual is divided into the following chapters:

Chapter 1: Overview

An introduction to the Digital Audio Power Amplifier.

Chapter 2: Functions and indications

Detailed descriptions of the functions and indications of the Digital Audio Power Amplifier.

Chapter 3: Connection and operation

Detailed descriptions of the connection and operation of the Digital Audio Power Amplifier.

Chapter 4: Specifications

Main technical parameters of Digital Audio Power Amplifier.

This manual is applicable to:

HPA-160D/02

Digital Audio Power Amplifier (2 channels, 2 × 200 W, Dante interface)

HPA-160A/02

Digital Audio Power Amplifier (2 channels, 2 × 200 W)

Chapter 1 Overview

Digital audio power amplifier (hereinafter referred to as "PA") adopts the high efficiency class D power amplifier and switching mode power supply technology; the efficiency under conventional conditions is more than 80%.

Features:

- Less heat, low working temperature, life span and reliability will be significantly improved.
- Energy saving and environmental protection, saving operating costs.
- Digital power amplifier + switching mode power supply, high efficiency, small size, light weight.

Output power: 2×200 W (4 Ω / 6 Ω)

2×160 W (8 Ω)

1×400 W (bridge/ constant voltage)

Frequency response:

20 Hz ~ 20 kHz (8 Ω)

THD: < 0.04%

- Wide operating voltage range: 100-240 VAC (± 10%)
- Two SPEAKON sockets for loudspeaker
- 2 × RJ45 socket for digital audio transmission via Dante™ networking (HPA-160D/02)
- 1 Line In and 1 Line Out (Ø6.4 mm phone jack)
- The user can access the IP address of power amplifier from web browser to set parameters and view device status, e.g. compressor, equalizer, DRC, etc.
- Perfect protection functions: short circuit protection, over temperature protection, DC protection, etc.

Chapter 2 Functions and indications

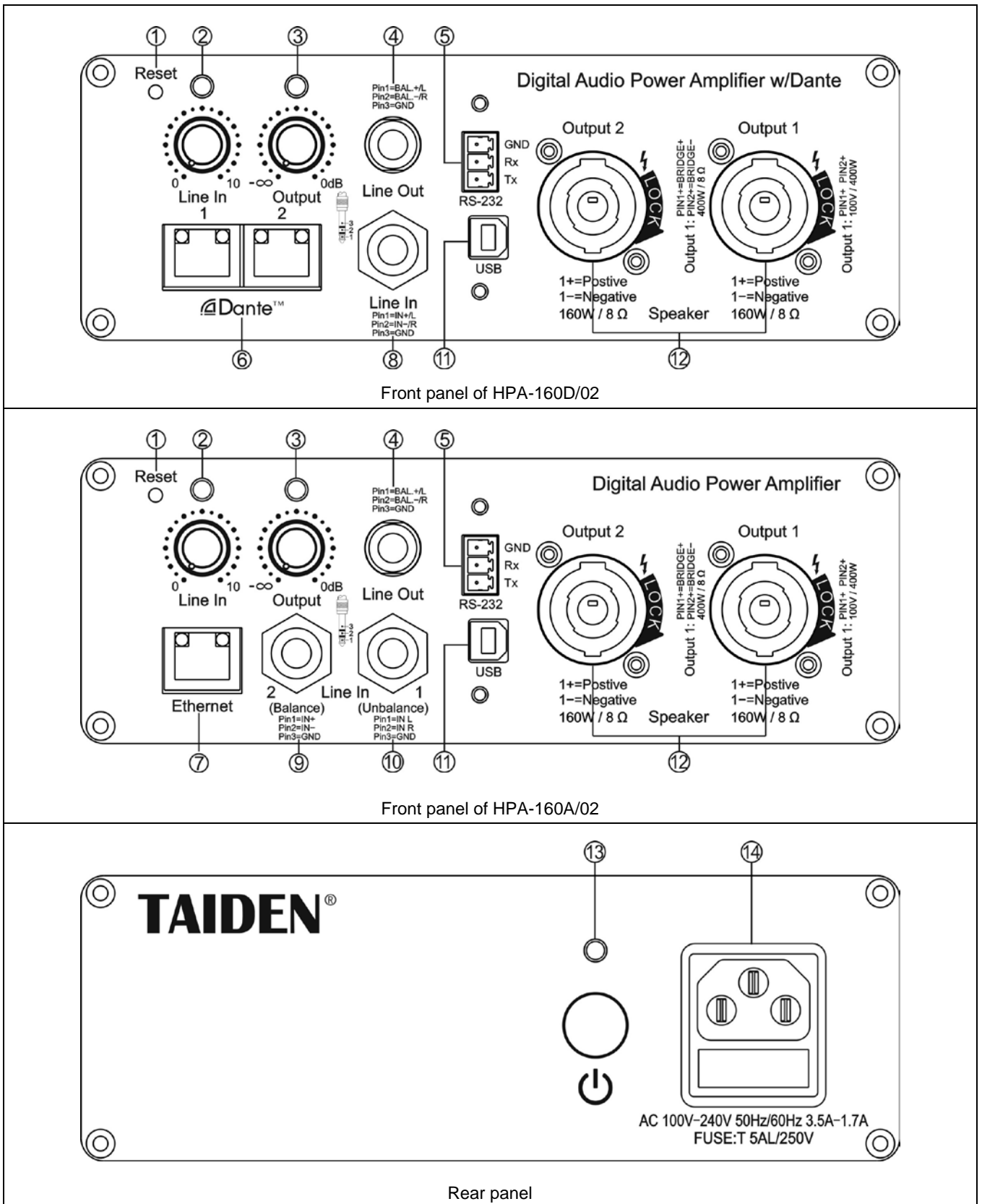

Figure 2.1 Digital audio power amplifier

1. Reset

- Press 3 times continuously restore PA to factory and rebooted.

2. Volume Gain control for Line In

3. Volume Gain control for loudspeaker

- Gain is controlled by dB attenuation. With the minimum set, the signal is completely cut off.

4. Line Out

- Ø6.4 mm TRS socket for signal loop output, can be connected to the Line In interface of the next power amplifier.

5. RS-232 control interface

- Connecting to central control system;
- Slave mode.

6. Dante interface

- Connecting to Dante network to transmit audio signal;
- For web function;
- Can be used for firmware updating.

7. Ethernet

- Connecting to Ethernet for web function;
- Can be used for firmware updating.

8. Line In

- Ø6.4 mm TRS socket for signal input;
- Supports Balance/Mono/Stereo signal.

9. Line In 2

- Ø6.4 mm TRS socket for balance signal input.

10. Line In 2

- Ø6.4 mm TRS socket for mono or stereo signal input.

Note: the signal input mode here need to be consistent with the input mode setting for the web interface.

11. USB audio signal input interface

- For external digital audio input.

12. Power output

- Four pole SPEAKON speaker sockets;
- Mono/Stereo mode output: Output1/Output2, 1+=Positive, 1-=Negative;
- Bridge mode output: Output1, PIN1+=BRIDGE+, PIN2+=BRIDGE-.

13. Power switch and indicator

- Power on/off;
- Indicator status:
Power on: green
Update/protect: orange

14. Power connector

- 100 V - 240 V, 50 Hz / 60 Hz.

Chapter 3 Connection and operation

3.1 Input/Output

Connecting knowledge:

- ◆ For input, use the shielded wire with high shielding layer density;
- ◆ Balanced connection to reduce noise interference;
- ◆ For unbalanced connection, the shorter the cable is the better. Maximum length does not exceed 3 meters;
- ◆ Keep signal cables isolated from power cable and PA output cable to avoid noise;
- ◆ Please power off all devices before changing connection; otherwise it may cause damage to the hearing and loudspeakers.

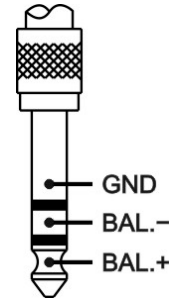

Connection diagram: balanced analog input/output

3.2 Connection

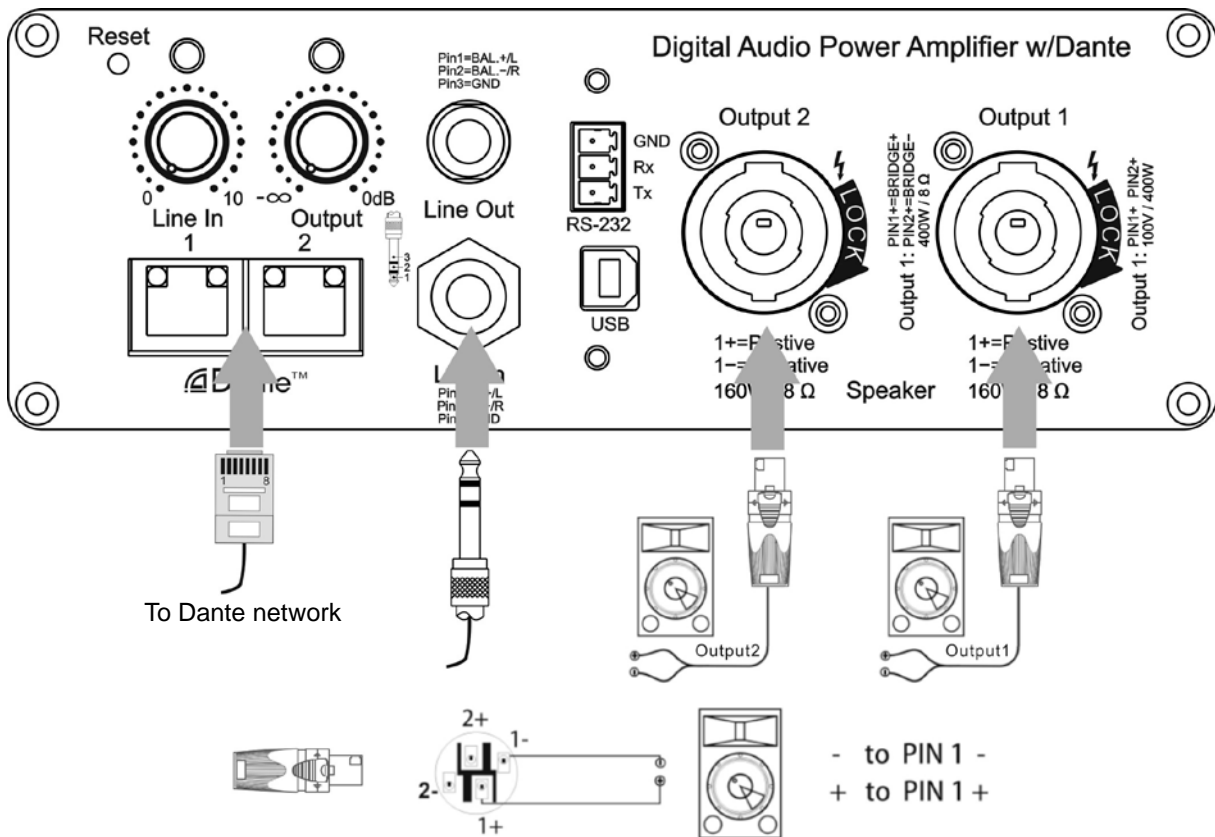

Figure: mono/stereo mode

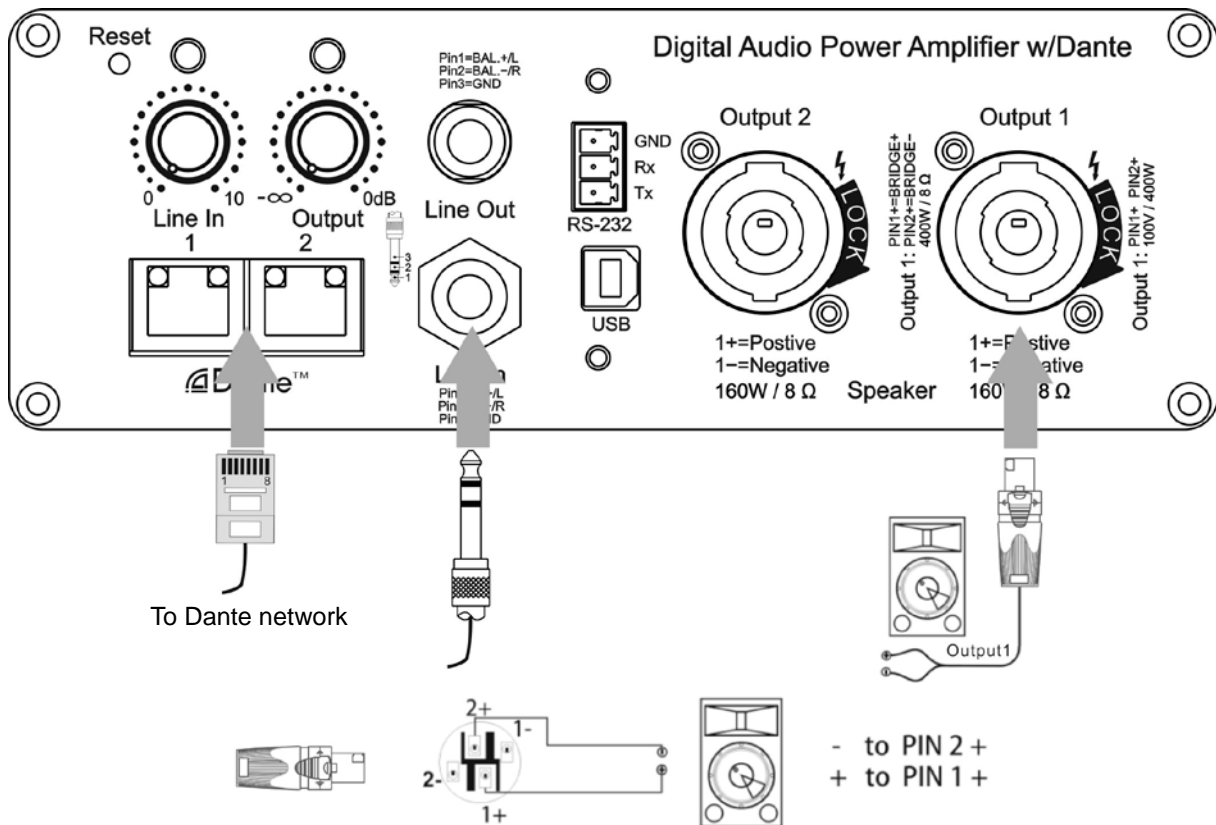

Figure: bridge mode

Note: HPA-160A/02 has no Dante function.

3.3 Operating instructions

Please confirm before installation:

- ◆ The power cord not connected to the power socket;
- ◆ The power switch is off;
- ◆ Volume knob turned off (counterclockwise to limit).

3.3.1 Protect speaker

Clipping not only makes the sound quality worse, but also damages the treble unit.

The speaker drive circuit may be burned by strong infrasound signal. The sound of breathing and the high level and low frequency signal caused by the dropping of the microphone are typical infrasound signals. To prevent infrasonic signals, one of the following methods should be used:

- ◆ Install high pass filter between the mixer output and PA input;
- ◆ Open the high pass filter in the mixer. Set the filter frequency as high as possible without affecting the use. For example, set to 35 Hz for music signal and 75 Hz for microphone signal. For each

mixer input channel, the filter frequency is set below the minimum fundamental frequency of the related channel.

3.3.2 Matters need attention

Although PA will be protected under exceptional circumstances, please pay attention to the use of PA in order to achieve the best performance and maximum safety:

1. It is necessary to configure PA before use, including the connection of input and output cables, improper wiring will result in equipment failure;
2. Before turning on the power supply of the device, make sure that the volume control knob is adjusted to the minimum. Otherwise, sudden bursts of sound may damage your hearing;
3. Do not connect the ground wire of the output cable and the ground wire of the input signal, which will form ground loop and cause oscillation;

4. Do not connect the output to the power supply, battery or mains supply. Otherwise it may cause an electric shock;
5. Tampering with the circuit or unauthorized modification of the circuit can be dangerous and cause all services provided by the agent fail;
6. Please do not make mixer overload, otherwise it will send the clipping signal to PA, and PA will precisely reproduce these signals and speakers may be damaged;
7. Do not use PA below the nominal load, too low load may cause PA output protection and premature clipping may damage the speaker;
8. When PA is switched on, the output interface may have a fatal voltage.

Note: TAIDEN is not responsible for any damage caused by excessive use of other system components.

3.4 Web control

Operating environment: Firefox, Chrome, or IE11 or higher.

Factory default network setting:

IP	192.168.1.60	Gateway	192.168.1.1	Netmask	255.255.0.0
----	--------------	---------	-------------	---------	-------------

Input IP address in browser to enter web server, or search HPA-160/02 with TAIDEN Device Discovery, as shown below:

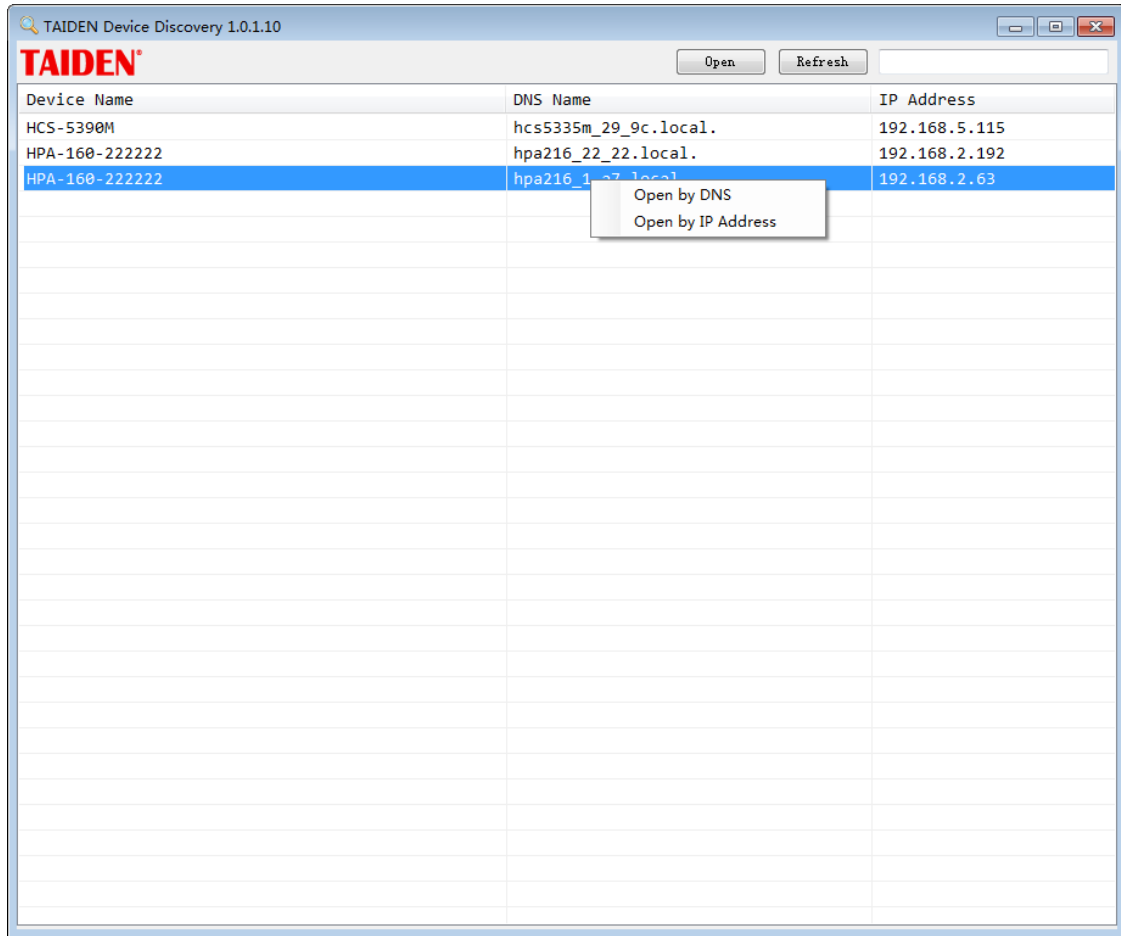

Figure: search device

How to enter Web server:

- Input default IP address: 192.168.1.60 (if cannot modify the network parameters) in the web browser;
- Or, Using TAIDE Device Discovery tool, select the device, click "Open" button;
- Or, Using TAIDE Device Discovery tool, select the device, right click on it, and click " Open by DNS / Open by IP Address";
- Or, input the IP address of the device (for example 192.168.2.63) in the web browser.

Web interface for HPA-160D/02 is shown below, and HPA-160A/02 has no Dante function. Two icons at the top-right are "Channel Parameters (≡)" and "System Setting (⚙)".

● **Channel Parameters**

When input mode is "Balance", the web interface will display channel 1/2/3; when input mode is "Mono/Stereo", the web interface will display channel 1/2/3/4; please use DanteController to assign input signals for Dante input; channel 5 is the mixer out of PA. "MUTE" button can be used to mute corresponding Channel. Click "DSP" to open DSP setting interface.

Note: please click "Save" after DSP settings in order to recall it expediently next time.

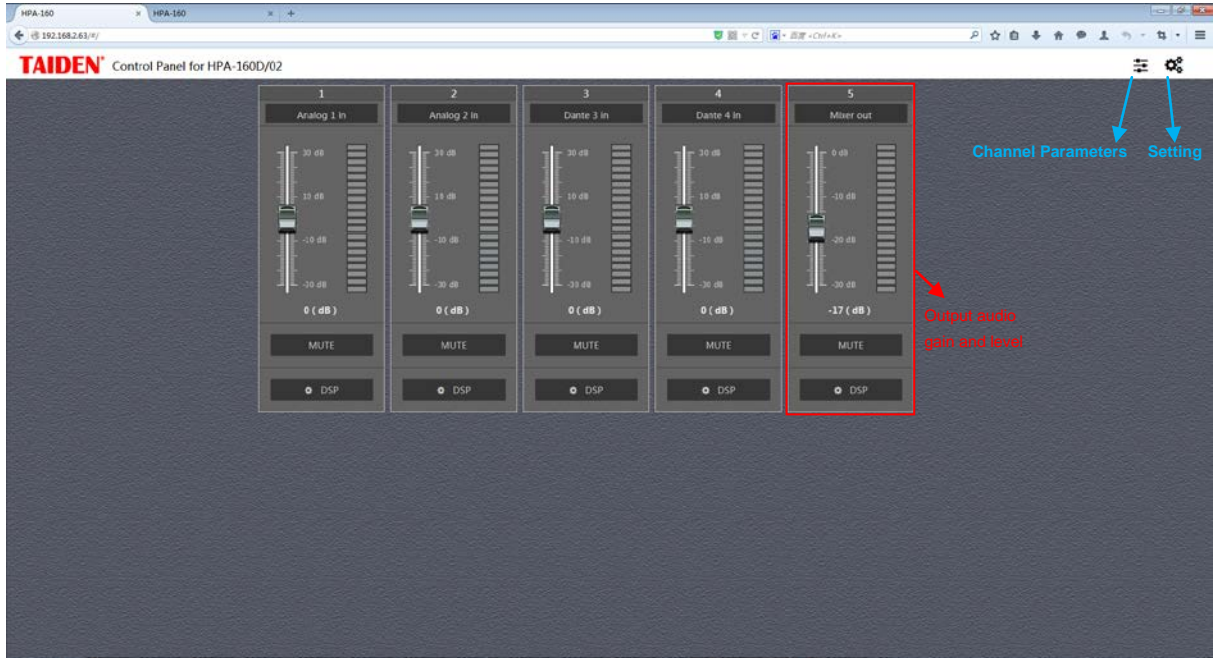

Figure: Channel Parameters

Click "DSP" button to go to DSP setting interface. Select channel in drop-down box, and DSP parameters can be saved in scene, supports up to four scenes. Click "Reset" on any scene to reset parameters to 0 dB settings, click "Save" to save parameters, click scene name to call scene.

PEQ:

In PEQ (parametric equalizer) interface, frequency response curve is displayed at the top. The default parameter curve is a straight line. Channel name and gain are displayed at the bottom. There are 5 filters with type of "Parametric", "Low Shelf", and "High Shelf". And "Freq.", "Gain" and quality "Q" can be set.

Note:

☞ Scene parameters of mixer out can be set and saved.



Figure: PEQ of input channel

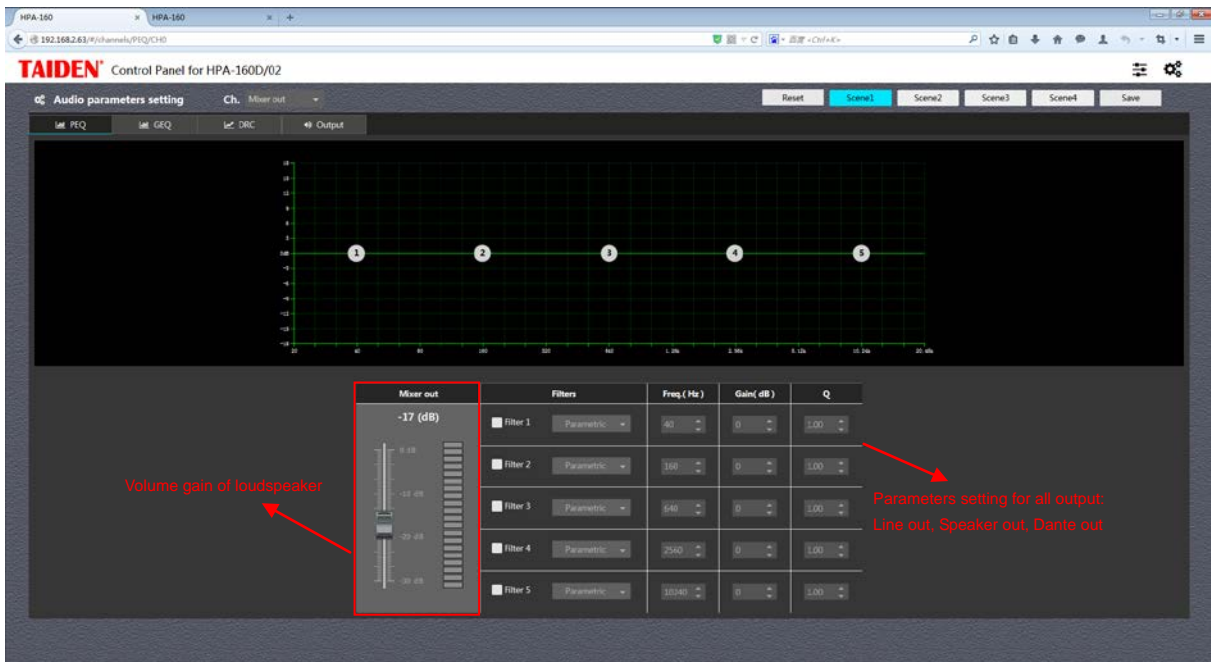

Figure: PEQ of output channel

GEQ:

31 segment graphical equalization, drag pushers to adjust equilibrium parameter. It is only for output channel. You can also enable/disable low-cut and high-cut features, and set their frequency point.

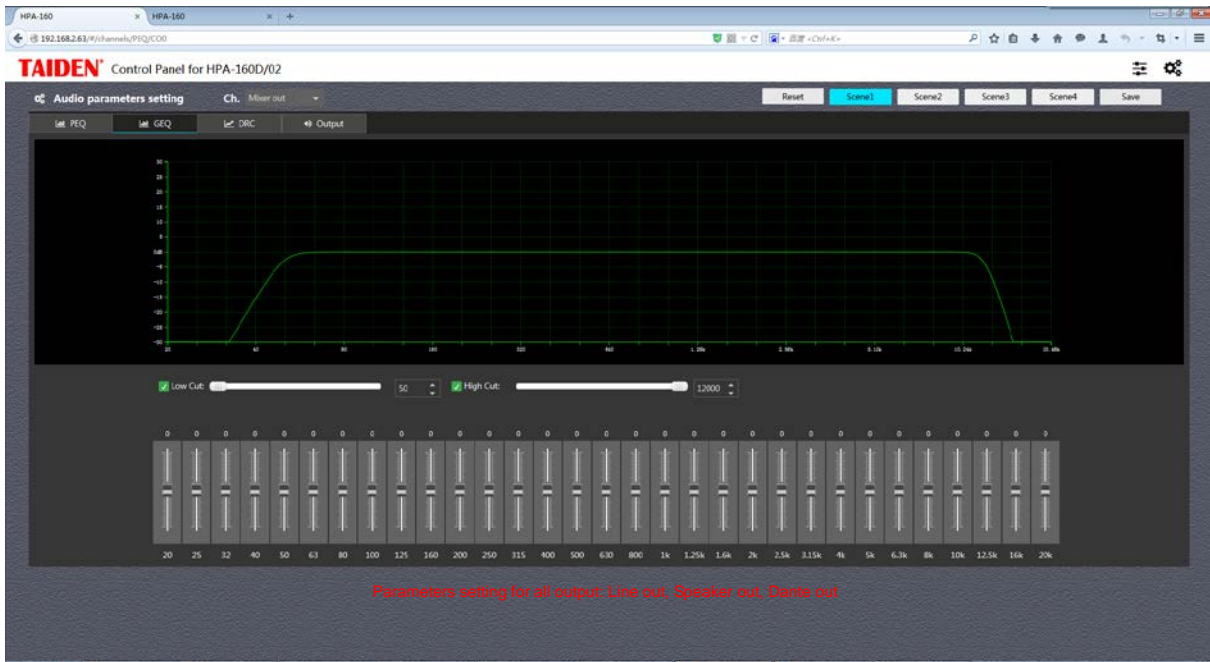

Figure: GEQ of output channel

DRC:

DRC (dynamic ratio compressor) interface is shown as below. It is only for output channel. Threshold, Ratio, Attack Time and Decay Time can be set.

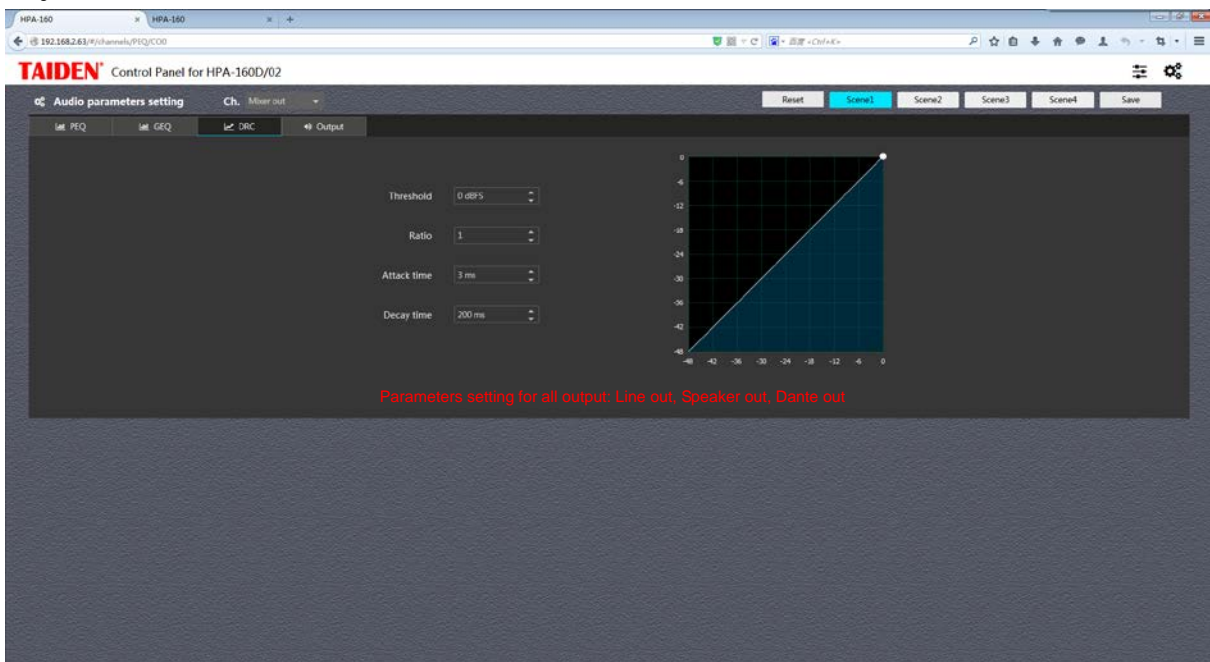

Figure: DRC of output channel

Speaker Output:

Speaker Output setting is only for Output1 and Output2 of HPA-160/02. Three speaker sound effects can be select: Normal, Music and Speech. Delay and mute can be setting for each output.

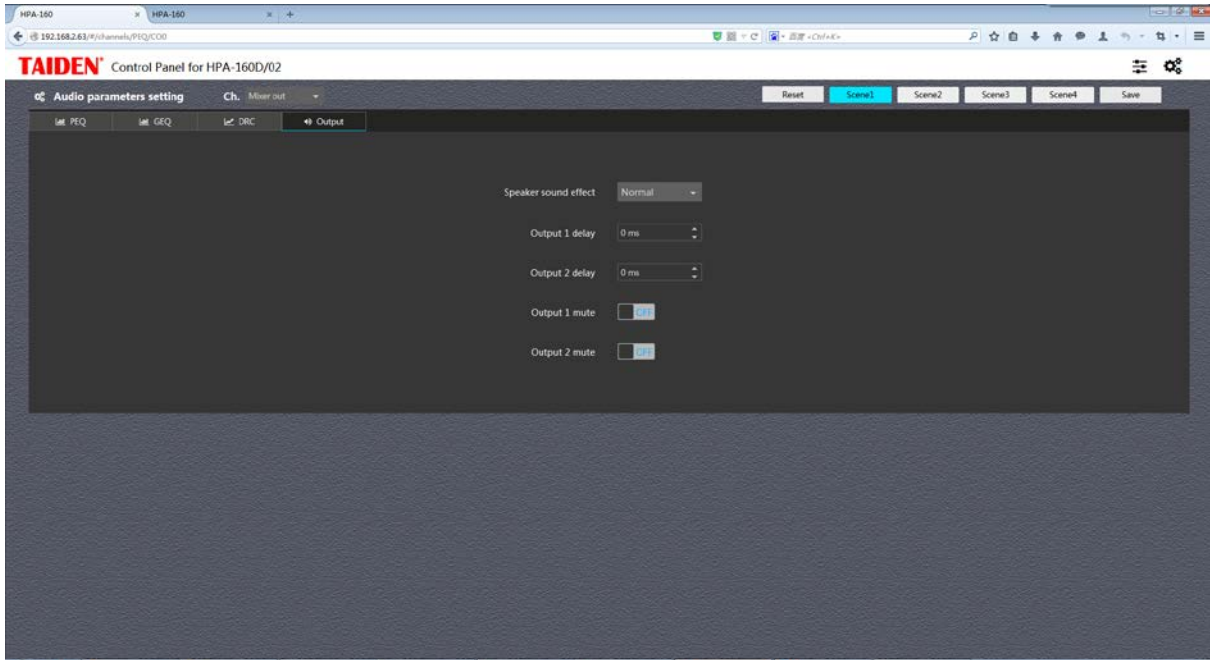

Figure: Speaker output setting

● **System Setting**

Device information and Dante information can be viewed in system setting page, the following items can be modified:

- Device name;
- DHCP: ON/OFF, when DHCP is OFF, IP Address, Netmask and Gateway can be set;
- Input mode: Stereo, Balance and Mono;
- Input source: 2 Analog + 2 Dante Chs, 4 Dante Chs;
- Sound test: Normal, Sine wave, White noise and Pink noise for selection, and its volume can be adjusted via analog 1; it can be used to detect the integrity of sound reinforcement system; it also can provide audio signals for acoustic environment detection, and adjust DSP parameters according to acoustic environment detection result in order to achieve a more perfect sound reinforcement effect;
- Low power: ON/OFF;
- Work state: Normal/Standby/Fault
 - When lower power is off, the state is normal;
 - When lower power is on and with audio output, the state is normal;
 - When lower power is on and without audio input, the state is standby;
 - When short circuit or overload protection happened, the state is fault;
- Select language: English and Chinese.

The relationship among input mode, input source and output is as follows:

	2 Analog + 2 Dante Chs	4 Dante Chs
Stereo	Analog1 and Analog2 to output1 and output2; Dante3 and Dante4 mixed to all outputs	✘
Balance	Mixer audio to all outputs	✘
Mono	Mixer audio to all outputs	Mixer audio to all outputs

Note:

☞ The “Restore” button in the upper-right corner of the interface is used to restore the default setting of the PA, shutting down the page and restarting the PA to take effect, and the IP address is restored to default: 162.168.1.60.

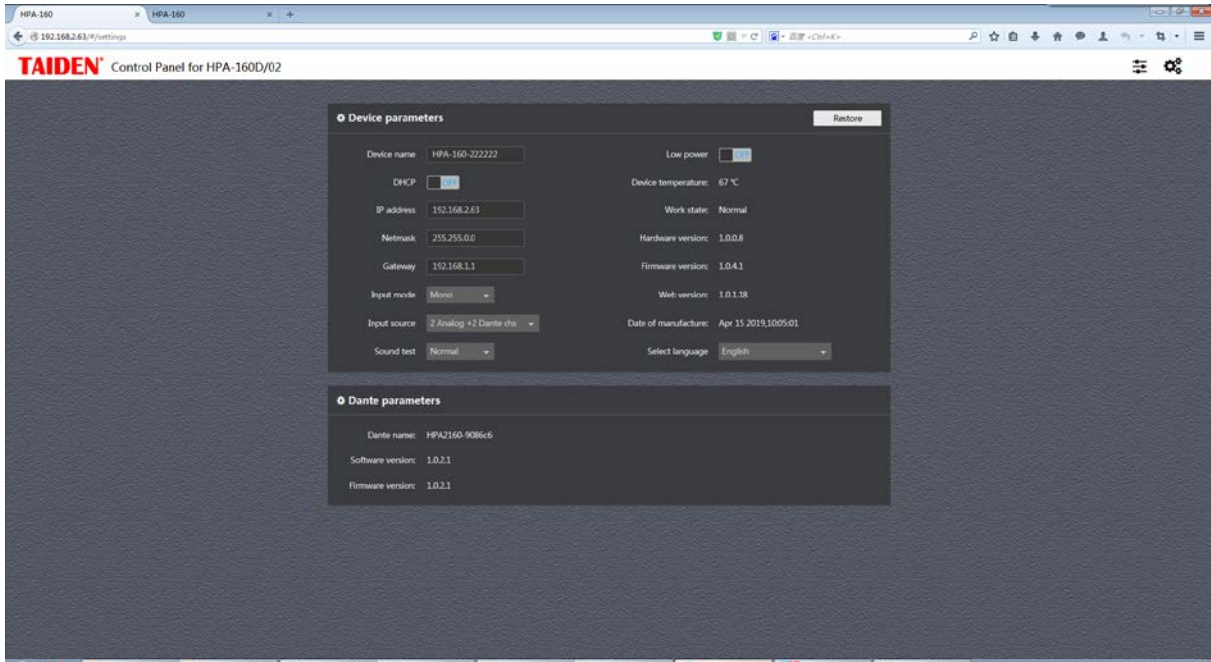

Figure: parameters of PA

Chapter 4 Specifications

PA	HPA-160/02
Rated power (EIAJ THD=1%, 1 kHz)	2×200 W (4 Ω / 6 Ω)
	2×160 W (8 Ω)
	1×400 W (8 Ω, Bridge)
	1×400 W (4 Ω / 6 Ω, Bridge)
	1×400 W (70 V Constant voltage)
	1×400 W (100 V Constant voltage)
Voltage gain (8 Ω, 1 kHz)	24.0 dB
Rising slope (1 kHz, Bypass low-pass filter)	50 V/μs
Input sensitivity (Rated power, 1 kHz)	3.5 Vrms
THD+N (10% Rated power, Typical value)	0.04%
IMD-SMPTE (10% Rated power, Typical value)	0.05%
DIM30 (10% Rated power, Typical value)	0.05%
Crosstalk suppression (Below rated power, 20 Hz - 1 kHz)	≥ 70 dB
Frequency response (10% Rated output power, 8 Ω, 20 Hz - 20 kHz)	± 1 dB
Input impedance	20 kΩ (Balanced), 10 kΩ (Unbalanced)
Damping coefficient (8 Ω, 20 Hz - 100 Hz)	≥ 200
SNR (A weighted, 20 Hz - 20 kHz)	≥ 95 dB
Power supply	100-240 VAC, 50/60 Hz
Protection	Short circuit protection, over temperature protection, DC protection
Box dimension (h × w × d, mm)	62 × 179 × 252
Product weight	1.7 kg

Chapter 5 RS-232 control

1. RS-232 Setting

Baud Rate	115200
Hardware flow control	None
Data format	Start bit: 1, Data bit: 8, Stop bit: 1, Parity bit: None

2. Control format

type - print type

mode - print input source, input mode

pwr - set PA on/off. Syntax: **pwr <status>**

status: on/off

vol - set input volume. Syntax: **vol <channel> <volume>**

channel: ch1/ch2/ch3/ch4/spk

volume:

ch1~4: 0x80(mute), 0~60(-30dB~+30dB)

spk: 0x80(mute), 0~30(-30dB~0dB)

? - print this help

Note: please press the Enter key after command is entered.

3. Instruction of volume control

Volume control command format: "**vol <channel> <volume> Enter**"

<channel> stands for audio channel, details to the following table

<volume> stands for audio volume, 0x80: mute, 0~60 for -30 dB ~30 dB

1) HPA-160D/02 input interface: LineIn(Balance/Stereo/Mono × 2), Dante1,Dante2

Input source	Input mode	Input channel				Output channel
		CH1	CH2	CH3	CH4	SPK
Dante × 4		Dante1	Dante2	Dante3	Dante4	Loudspeaker volume
Analog × 2 + Dante × 2	Balance	LineIn	Non	Non	Non	Loudspeaker volume
	Stereo	LineIn-L	LineIn-R	Dante3	Dante4	Loudspeaker volume
	Mono	LineIn-1	LineIn-2	Dante3	Dante4	Loudspeaker volume

2) HPA-160A/02 input interface: LineIn 2(Balance), LineIn 1(Stereo/Mono × 2)

Input source	Input mode	Input channel				Output channel
		CH1	CH2	CH3	CH4	SPK
Analog × 2	Stereo	LineIn1(Balance)+LineIn2(LR)	Non	Non	Non	Loudspeaker volume
	Mono	LineIn1(Balance)+LineIn2(1+2)	Non	Non	Non	Loudspeaker volume

TAIDEN INDUSTRIAL CO., LTD.

6/F, Block B, Future Plaza, 6060 Qiaoxiang Rd, Nanshan District, Shenzhen, China

P.C.: 518053

Website: <http://www.taiden.com>

Copyright by TAIDEN

Last Revision: 04/2020