

**Floor model
Twin twist flavor
Independent refrigeration and
control system for each flavour**

6248

6248 Gravity Feed

Feature

Offer all the popular soft serve variations from low or non-fat ice creams to custards,yogurt and sorbet.

Freezing Cylinder

Two, 1.8 Liter

Mix Hopper

Two, 12.5 Liter
Separate hopper refrigeration(Pre-cooling)maintains mix below 4.4°C.

Microprocessor Controls

Microprocessor regulates refrigeration by measuring product viscosity to maintain consistent quality.

Mix low light

The mix low light turns "ON" to alert operator to add mix,Preventing cylinder over freezing.

Standby

Maintains product temperature in the mix hoppers and freezing cylinders below 4.4°C during long no-use periods.

Counter

Records number of dispenses per day and total number of dispenses.

Agitator in the hopper

Mixture has better liquidity, the temperature of the Mix to be more uniform.

Output

48 Liter/Hour
(At 4°C Liquid &24°C Ambient)



Flexible blade beater
Higher capacity, higher overrun

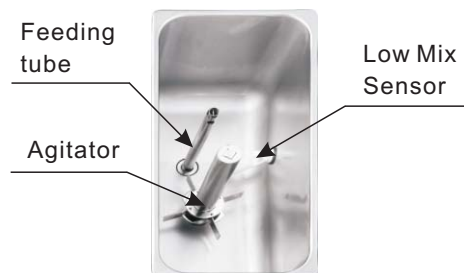

6248

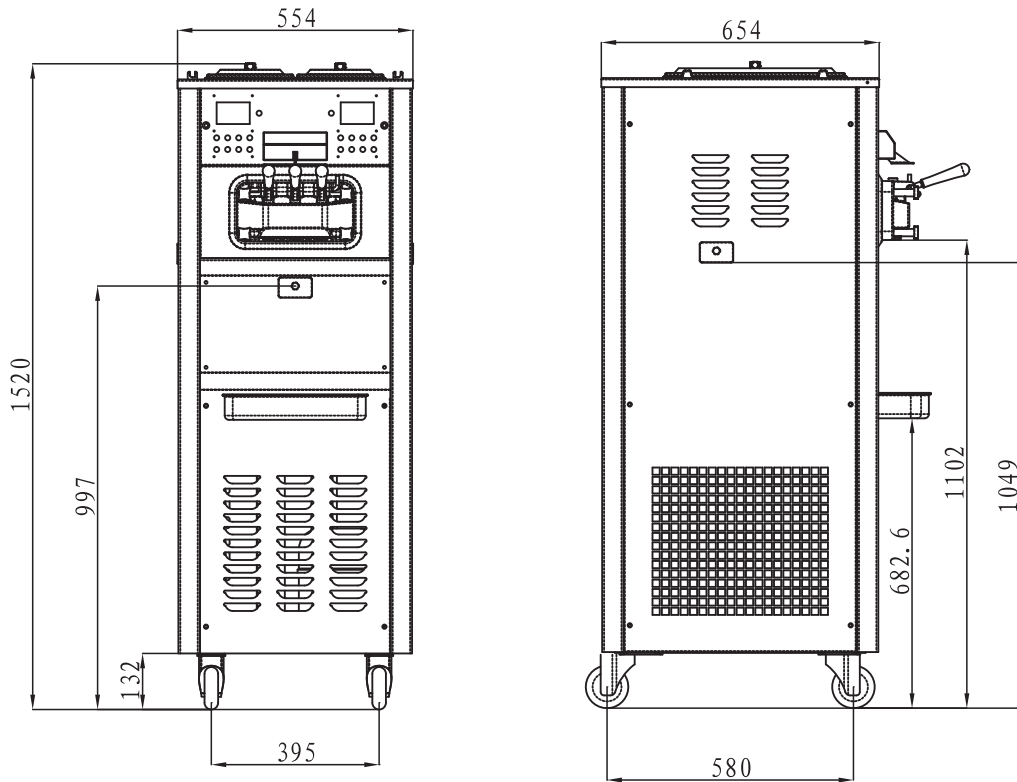

Equipment parameters

Model	Dimension(mm) (NET)	Dimension(mm) (PACKING)
6248	654x554x1520	800x645x1665

Model	N.W.(kg)	G.W.(kg)
6248	215	235

Model	Voltage	Power
6248	210-230V/50Hz	3.4KW

Electrical requirements

One dedicated electrical connection is required.
Make voltage steady when machine is ON.

Main motor

Two, 1.25HP

Refrigeration system

Two compressors:2x3393 BTU/hr.R404a
Separate hopper refrigeration(Pre-cooling):
One compressor:400BTU/hr.R134a
(BTU may vary depending on compressor used.)

Air Cooled

Minimum clearance of 152mm on both sides is to
achieve optimum performance.

Refer to the local situation to regulate the parameters,
on basic of the data label.Specifications of the
improvements are subject to change without notice.

PACKING: CARTON WITH PALLET
LOADED IN 20' CONTAINER: 25 UNITS
LOADED IN 40' CONTAINER: 50 UNITS

Options

- Power Supply :208-230V/60HZ/1PH 380-415V/50HZ/3PH
- Water Cooled
- Cone Dispenser