



# **Datasheet of Wireless Bio-Radar Sensor for Human Presence Detection IR24VDA**



Dalian iFlabel Technology Co., LTD.

# Specification

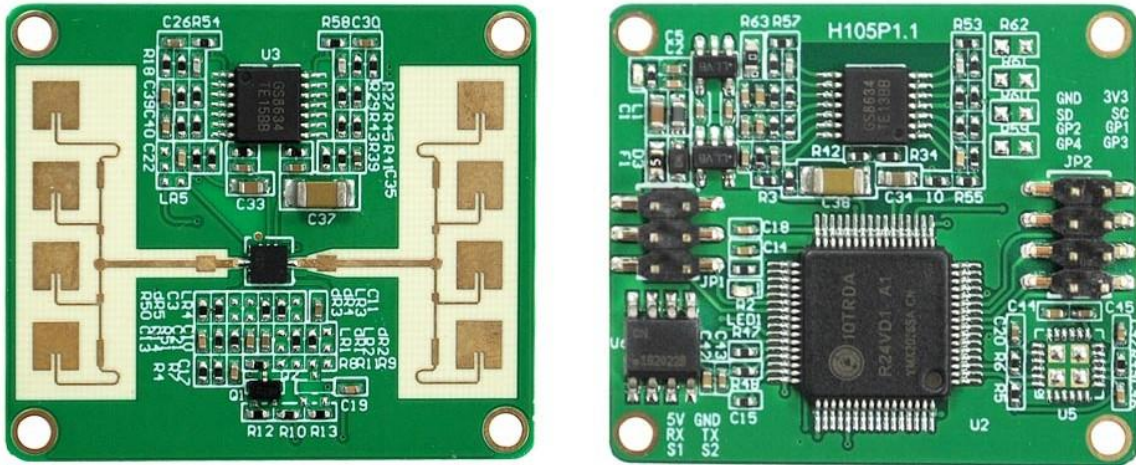

<b>Model</b>	<b>Standard</b>
<b>Description</b>	<b>Wireless Bio-Radar Sensor for Human Presence Detection</b>
<b>Part Number</b>	<b>IR24VDA</b>
<b>Date</b>	<b>2021/03/19</b>
<b>Version</b>	<b>1.1</b>

	Design Team		
	Approval	Check	Edit
			

R.1513, Zhongnan Building Block A, NO.18 Zhonghua W. Rd, Ganjingzi Dist, Dalian

Tel: +86-411-84619565  
 Email: info@iflabel.com  
 Site: www.iflabel.com

## Contents

Overview.....	4
1. Operating Principle.....	4
2. Precautions for Hardware Design.....	5
2.1. Circuit for Reference of Power Supply Design.....	5
2.2. Wiring Diagram.....	6
3. Layout Requirements of Antenna and Case.....	6
4. Electrostatic Protection.....	7
5. Factors Interfering Radar Function.....	7
5.1 Abnormal Output of Nobody State.....	7
5.2 Abnormal Output of Somebody State.....	8
6. Functions.....	9
6.1. Description of Functions.....	9
6.2. Output Description of Body Motion Amplitude Parameters.....	9
7. Instruction of Protocol.....	10
8. Communication Commands and Parameter Definition.....	10
8.1. Definition and Instruction of Frame Structure.....	10
8.2. Address Distribution and Data Information Instruction.....	11
Appendix 1: Parsing Code for Reference of CRCCheck Code.....	14
Appendix 2: Parsing Code for Reference of Body Motion Sign Parameters.....	16

## Overview

This document mainly describes the use of the radar and the problems needing attention in each stage, so as to reduce the design cost and increase the stability of the product as much as possible and improve the completion efficiency of the project.

From the hardware circuit reference design, the layout requirements of radar antenna and shell, how to distinguish interference and multifunctional standard UART protocol output.

The radar is a self-contained space sensing sensor, which is a module composed of RF antenna, radar chip and high-speed main frequency MCU. Relying on the stable, flexible and superior algorithm architecture core, the radar can solve the user's various scene detection needs. It can be equipped with upper computer or host computer to flexibly output detection status and data, meet several groups of GPIO, and can be customized and developed by users.

## 1. Operating Principle

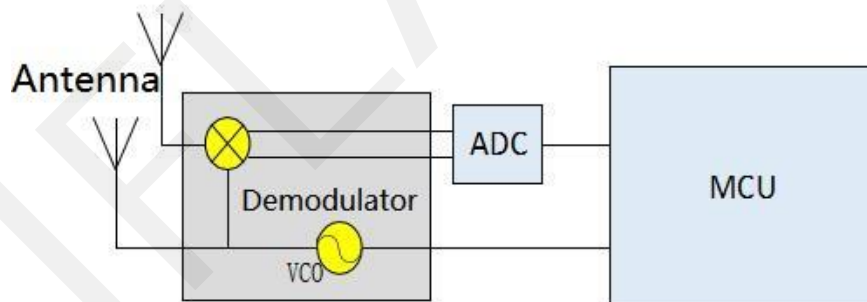

The radar transmits 24G band millimeter wave signal, the measured target reflects electromagnetic wave signal, demodulates the transmitted signal, and then obtains echo demodulated signal data through amplification, filtering, ADC and other processing. The amplitude, frequency and phase of echo signal are solved in MCU unit, and finally the measurement of target parameters (breathing, motion, micro motion, etc.) and scene evaluation are realized.

## 2. Precautions for Hardware Design

The rated power supply voltage of the radar shall meet 4.9 - 6V.

Under normal working conditions, the rated current requires an input of more than 200mA. Power supply design, power ripple shall be  $\leq 100\text{mV}$ .

### 2.1. Circuit for Reference of Power Supply Design

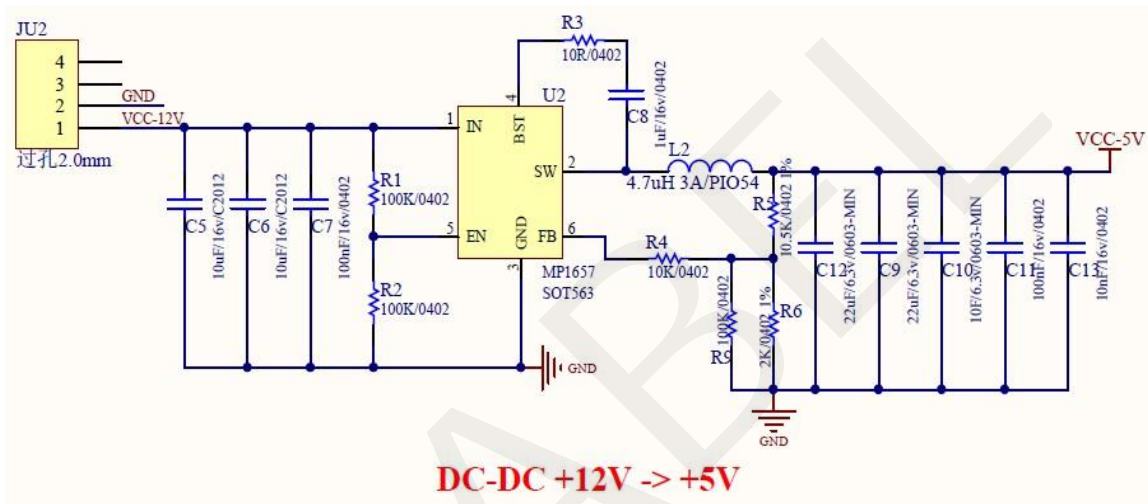

Figure. 1

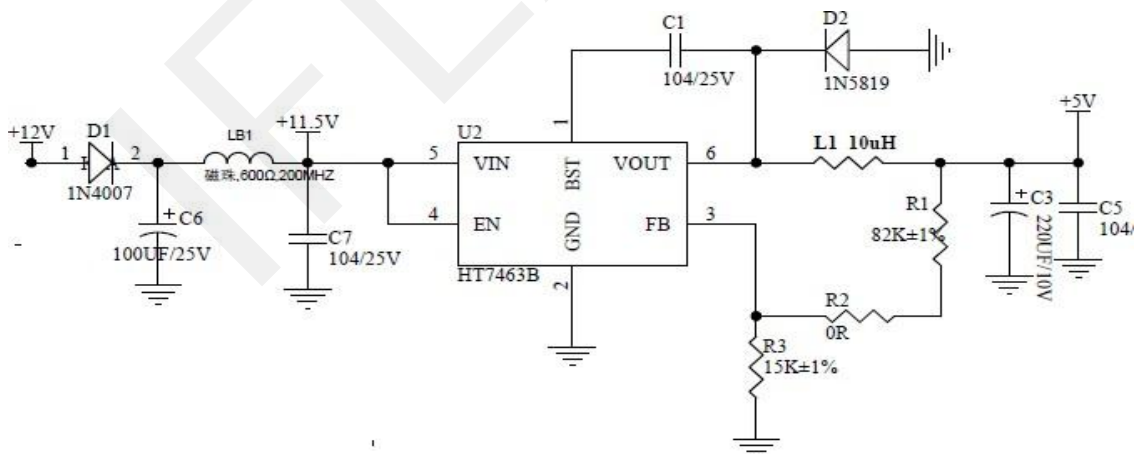

Figure. 2

## 2.2. Wiring Diagram

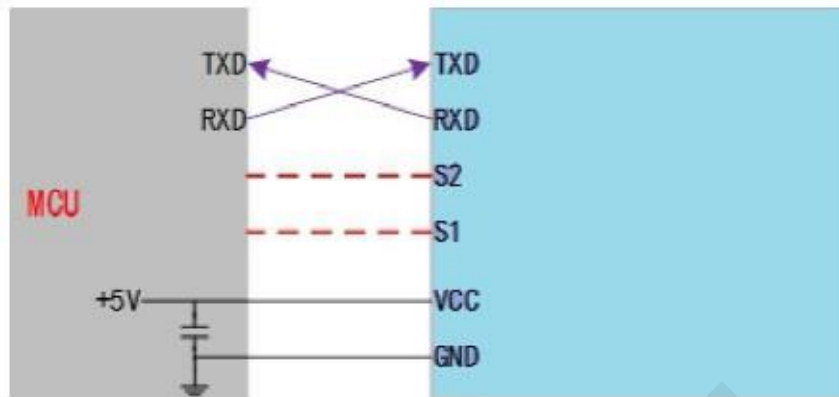

Figure 3. Wiring Diagram of Radar Module and Peripheral Device

## 3. Layout Requirements of Antenna and Case

PCBA: Height of Radar Mount Above Other Components  $\geq 1\text{mm}$

Case Structure: Radar Antenna Plane to Case: 2 - 5mm

External Detection Surface: Non-metallic plane, no curve to avoid affection on performance of detection coverage

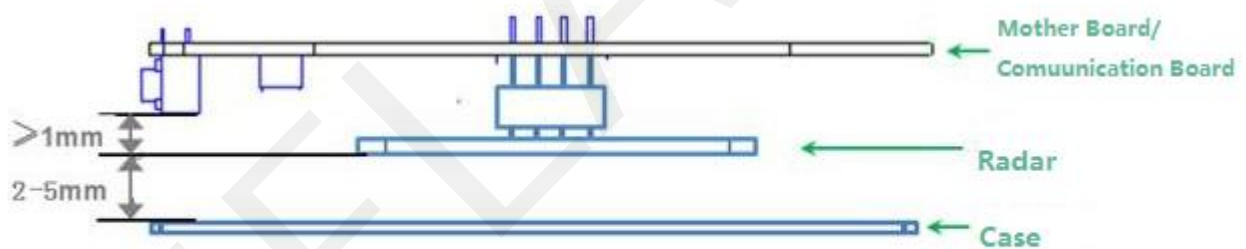

Figure 4

## 4. Electrostatic Protection

The radar product has an electrostatic sensitive circuit inside, which is vulnerable to electrostatic hazards. Therefore, it is necessary to do a good job in electrostatic protection in the process of transportation, storage, work and taking. Do not touch and grasp the antenna surface and connector pins of the radar module, but only the corners.

When operating the radar sensor, please wear anti-static gloves.

## 5. Factors Interfering Radar Function

### 5.1 Abnormal Output of Nobody State

- A.** Movements from doorway, the other side of wooden wall detected due to too large radar scanning coverage  
Adjustment: Tune down sensitivity and set up scenario for radar
- B.** Radar faces down air-conditioning, fan in operating  
Adjustment: Readjust the position of radar
- C.** Swinging objects by airflow from air-conditioning  
Adjustment: Cotton, non-metallic objects will not cause false-alarm and metallic objects need to be fixed
- D.** False alarm by Vibration of Radar not fixed  
Adjustment: Avoid shaking or vibration
- E.** Pets, flying birds or other moving objects  
Adjustment: Because of the high sensitivity of slight motion detection, this cannot be excluded
- F.** False judgement from interference of power supply  
Adjustment: Stabilize the current and reduce ripple

## 5.2 Abnormal Output of Somebody State

**Radar judges human presence via sending and receiving electromagnetic wave, closer to radar, higher the accuracy**

- A.** Human body beyond radar scanning coverage  
Adjustment: Readjust the installation angle. Detection range varies slightly in different environments due to different reflection coverage
- B.** False output due to shading by metallic objects  
Too thick office desks, chairs made from metal will block electromagnetic wave and cause a false alarm
- C.** Difference in scanning angle  
Adjustment: Human body not scanned by radar, causing a false alarm
- D.** Low sensitivity of radar  
Adjustment: Use parameter condition of radar to improve



## 6. Functions

### 6.1. Description of Functions

Function Points	Time of State Change/Explanation
DP1: somebody/nobody	nobody to somebody, report within 0.5s somebody to nobody, output "No" in 1to 2mins
DP2: stationary/active	shift between stationary and active, report within 0.5s
DP3: personnel approaching/leaving/no directional movement	output every 2s
DP4: parameter of body motion amplitude from 0 – 100	output every 5s refer to (section 6.2)
DP5: sensitivity gear from 0 – 9	10 gears for default scenario
DP7: scenario (bed,bathroom,hotel,bedroom,office, default)	different scenarios according to size of coverage
DP8: confirm reminder of false alarm of nobody	

### 6.2. Output Description of Body Motion Amplitude Parameters

Parameter of Body Motion Amplitude		
0%	nobody	nobody in environment
1%	stationary	no body movement only respiration
2%-30%	slight motion	slight motion from head or limbs
31%-60%	walk/quick body movement	relatively slow body movement
61%-100%	run/big movement in close distance	quick body movement

## 7. Instruction of Protocol

This protocol is applied to the communication between 24G millimeter wave detection radar and host computer.

This protocol briefly introduces the radar work flow, briefly introduces the composition architecture of the interface protocol, and gives the control commands and data required for relevant radar work. The definition of serial port communication is as follows:

**Interface level: TTL**

**Baud rate: 9600bps**

**Stop bit: 1**

**Data bit: 8**

**Parity check: No**

## 8. Communication Commands and Parameter Definition

### 8.1. Definition and Instruction of Frame Structure

#### A. Definition of Frame Structure

Initial Code	Data Length		Function Code	Address Code 1	Address Code 2	Data	Check Code	
0X55	Lenth_L	Lenth_H	Command	Address _1	Address _2	Data	Crc16_ L	Crc16_ H
1 Byte	1 Byte	1 Byte	1 Byte	1 Byte	1 Byte	n Byte	1 Byte	1 Byte

#### B. Instruction of Frame Structure

a b Initial code: 1Byte, default 0X55

Data length: 2 Byte, low byte first, high byte after

length=data length+function code+address code 1+address code 2+data+check code

c Function: 1Byte

Data read: 0X01

Data write: 0X02

Passive report command: 0X03

Active report command: 0X04

d Address: address code 1 function classify, address code 2 specific function

e Please refer to instruction of address distribution and data information

f.g Data: n Byte

Check code: 2 Byte, low byte first, high byte after

Use CRC16 for check, please refer to Appendix 1

## 8.2. Address Distribution and Data Information Instruction

Interface Contents of 24G					
Bio-perception Radar					
	Function code	Address code 1	Address code 2	Data	Remark
1	Read 0x01	Mark looking up 0x01	Device ID 0X01		
2			Software version 0x02		
3			Software version 0x03		
4			Protocol version 0x04		
		Looking-up radar information 0x03	Environment state 0X05		
11			Vital sign parameter 0x06		
12		System parameter looking-up 0x04	Threshold gear 0x0C		
			Scenario setting 0x10		
16	Write 0x02	System parameter 0x04	Threshold gear 0x0C	Enumeration range 0~9	Respectively to gear level 0 1 2 3 4 5 6 7 8 9 (default is 6 ) higher gear level, higher sensitivity
			Scenario setting 0x10	Default mode 0x00	
		Area detection ( Top-mounted ) 0x01			
		Bathroom ( Top-mounted ) 0x02			
		Bedroom ( Top-mounted ) 0x03			
		Living room ( Top-mounted ) 0x04			
		Office ( Top-mounted ) 0x05			
		Hotel ( Top-mounted ) 0x06			

		Other function 0X05	Restart 0X04		
17	Passive report command 0x03	Report Radar information 0x01	Device ID 0x01	12 Byte data	
18			Software version 0x02	10 Byte data	
19			Hardware version 0x03	8 Byte data	
20			Protocol version 0x04	8 Byte data	
27		Report Radar information 0X03	Environment state 0x05	Nobody 00 FF FF	
28				Stationary personnel 01 00 FF	
29				Active personnel 01 01 01	
30				Vital parameters 0x06	4 Byte Float data <b>(see appendix 2)</b>

	Passive report 0x03	Report other information 0X04	Threshold gear 0X0C	Current gear ( 0X00~0X09 )		
			Scenario setting 0x10	Default 0x00		
				Area detection ( Top-mounted ) 0x01		
				Bathroom ( Top-mounted ) 0x02		
				Bedroom ( Top-mounted ) 0x03		
				Living room ( Top-mounted ) 0x04		
				Office ( Top-mounted ) 0x05		
				Hotel ( Top-mounted ) 0x06		
31				Active report 0X04	Report radar information 0x03	Environment state 0x05
32	Stationary personnel 01 00 FF					
33	Active personnel 01 01 01					
34	Parameter of body motion 0X06		4 Byte Float data			
	Approaching/Leaving 0x07	Fixed character 0x01 0x01	No 0x01			
			Approaching 0x02			
	Report other information 0X05	Heartbeat 0X01	Nobody 00 FF FF			
			Stationary personnel 01 00 FF			
			Active personnel 01 01 01			
		Reset of abnormal 0X02	0X0F			

**Instruction:** 1) Data read/write:command sent from host computer to radar  
2) Report command:information sent from radar to host computer

## Appendix 1: Parsing Code for Reference of CRC Check Code

```

1. const signed char cuc_ RChi[56]=
2. un          C          2
   {
3.   0x00, 0xC1, 0x81, 0x40, 0x01, 0xC0, 0x80, 0x41, 0x01, 0xC0, 0x80, 0x41,
4.   0x00, 0xC1, 0x81, 0x40, 0x01, 0xC0, 0x80, 0x41, 0x00, 0xC1, 0x81, 0x40,
5.   0x00, 0xC1, 0x81, 0x40, 0x01, 0xC0, 0x80, 0x41, 0x01, 0xC0, 0x80, 0x41,
6.   0x00, 0xC1, 0x81, 0x40, 0x00, 0xC1, 0x81, 0x40, 0x01, 0xC0, 0x80, 0x41,
7.   0x00, 0xC1, 0x81, 0x40, 0x01, 0xC0, 0x80, 0x41, 0x01, 0xC0, 0x80, 0x41,
8.   0x00, 0xC1, 0x81, 0x40, 0x01, 0xC0, 0x80, 0x41, 0x00, 0xC1, 0x81, 0x40,
9.   0x00, 0xC1, 0x81, 0x40, 0x01, 0xC0, 0x80, 0x41, 0x00, 0xC1, 0x81, 0x40,
10.  0x01, 0xC0, 0x80, 0x41, 0x01, 0xC0, 0x80, 0x41, 0x00, 0xC1, 0x81, 0x40,
11.  0x00, 0xC1, 0x81, 0x40, 0x01, 0xC0, 0x80, 0x41, 0x01, 0xC0, 0x80, 0x41,
12.  0x00, 0xC1, 0x81, 0x40, 0x01, 0xC0, 0x80, 0x41, 0x00, 0xC1, 0x81, 0x40,
13.  0x00, 0xC1, 0x81, 0x40, 0x01, 0xC0, 0x80, 0x41, 0x01, 0xC0, 0x80, 0x41,
14.  0x00, 0xC1, 0x81, 0x40, 0x00, 0xC1, 0x81, 0x40, 0x01, 0xC0, 0x80, 0x41,
15.  0x00, 0xC1, 0x81, 0x40, 0x01, 0xC0, 0x80, 0x41, 0x01, 0xC0, 0x80, 0x41,
16.  0x00, 0xC1, 0x81, 0x40, 0x00, 0xC1, 0x81, 0x40, 0x01, 0xC0, 0x80, 0x41,
17.  0x01, 0xC0, 0x80, 0x41, 0x00, 0xC1, 0x81, 0x40, 0x01, 0xC0, 0x80, 0x41,
18.  0x00, 0xC1, 0x81, 0x40, 0x00, 0xC1, 0x81, 0x40, 0x01, 0xC0, 0x80, 0x41,
19.  0x00, 0xC1, 0x81, 0x40, 0x01, 0xC0, 0x80, 0x41, 0x01, 0xC0, 0x80, 0x41,
20.  0x00, 0xC1, 0x81, 0x40, 0x01, 0xC0, 0x80, 0x41, 0x00, 0xC1, 0x81, 0x40,
21.  0x00, 0xC1, 0x81, 0x40, 0x01, 0xC0, 0x80, 0x41, 0x01, 0xC0, 0x80, 0x41,
22.  0x00, 0xC1, 0x81, 0x40, 0x00, 0xC1, 0x81, 0x40, 0x01, 0xC0, 0x80, 0x41,
23.  0x00, 0xC1, 0x81, 0x40, 0x01, 0xC0, 0x80, 0x41, 0x01, 0xC0, 0x80, 0x41,
24.  0x00, 0xC1, 0x81, 0x40
25. };

```

```

1. const unsigned char cuc_CRCLo[256]=
2. {
3.     0x00, 0xC0, 0xC1, 0x01, 0xC3, 0x03, 0x02, 0xC2, 0xC6, 0x06, 0x07, 0xC7,
4.     0x05, 0xC5, 0xC4, 0x04, 0xCC, 0x0C, 0x0D 0xCD, 0x0F, 0xCF, 0xCE, 0x0E,
5.     0x0A, 0xCA, 0xCB, 0x0B, 0xC9, 0x09, 0x08, 0xC8, 0xD8, 0x18, 0x19, 0xD9,
6.     0x1B, 0xDB, 0xDA, 0x1A, 0x1E, 0xDE, 0xDF, 0x1F, 0xDD 0x1D, 0x1C, 0xDC,
7.     0x14, 0xD4, 0xD5, 0x15, 0xD7, 0x17, 0x16, 0xD6, 0xD2, 0x12, 0x13, 0xD3,
8.     0x11, 0xD1, 0xD0, 0x10, 0xF0, 0x30, 0x31, 0xF1, 0x33, 0xF3, 0xF2, 0x32,
9.     0x36, 0xF6, 0xF7, 0x37, 0xF5, 0x35, 0x34, 0xF4, 0x3C, 0xFC, 0xFD, 0x3D,
10.    0xFF, 0x3F, 0x3E, 0xFE, 0xFA, 0x3A, 0x3B, 0xFB, 0x39, 0xF9, 0xF8, 0x38,
11.    0x28, 0xE8, 0xE9, 0x29, 0xEB, 0x2B, 0x2A, 0xEA, 0xEE, 0x2E, 0x2F, 0xEF,
12.    0x2D, 0xED, 0xEC, 0x2C, 0xE4, 0x24, 0x25, 0xE5, 0x27, 0xE7, 0xE6, 0x26,
13.    0x22, 0xE2, 0xE3, 0x23, 0xE1, 0x21, 0x20, 0xE0, 0xA0, 0x60, 0x61, 0xA1,
14.    0x63, 0xA3, 0xA2, 0x62, 0x66, 0xA6, 0xA7, 0x67, 0xA5, 0x65, 0x64, 0xA4,
15.    0x6C, 0xAC, 0xAD, 0x6D, 0xAF, 0x6F, 0x6E, 0xAE, 0xAA, 0x6A, 0x6B, 0xAB,
16.    0x69, 0xA9, 0xA8, 0x68, 0x78, 0xB8, 0xB9, 0x79, 0xBB, 0x7B, 0x7A, 0xBA,
17.    0xBE, 0x7E, 0x7F, 0xBF, 0x7D, 0xBD, 0xBC, 0x7C, 0xB4, 0x74, 0x75, 0xB5,
18.    0x77, 0xB7, 0xB6, 0x76, 0x72, 0xB2, 0xB3, 0x73, 0xB1, 0x71, 0x70, 0xB0,
19.    0x50, 0x90, 0x91, 0x51, 0x93, 0x53, 0x52, 0x92, 0x96, 0x56, 0x57, 0x97,
20.    0x55, 0x95, 0x94, 0x54, 0x9C, 0x5C, 0x5D 0x9D, 0x5F, 0x9F, 0x9E, 0x5E,
21.    0x5A, 0x9A, 0x9B, 0x5B, 0x99, 0x59, 0x58, 0x98, 0x88, 0x48, 0x49, 0x89,
22.    0x4B, 0x8B, 0x8A, 0x4A, 0x4E, 0x8E, 0x8F, 0x4F, 0x8D, 0x4D, 0x4C, 0x8C,
23.    0x44, 0x84, 0x85, 0x45, 0x87, 0x47, 0x46, 0x86, 0x82, 0x42, 0x43, 0x83,
24.    0x41, 0x81, 0x80, 0x40
25. };

1. static unsigned shortint us_CalculateCrc16(unsigned char *lpuc_Frame, unsi
   gned short int lus_Len)
2. {
3.     unsigned char luc_CRCHi = 0xFF;
4.     unsigned char luc_CRCLo = 0xFF;
5.     int li_Index=0;
6.
7.     while(lus_Len--)
8.     {
9.         li_Index = luc_CRCLo ^ *(lpuc_Frame++);
10.        luc_CRCLo = (t_BYTE)( luc_CRCHi ^cuc_CRCHi[li_Index]);
11.        luc_CRCHi = cuc_CRCLo[li_Index];
12.    }
13.    return (unsigned short int )(luc_CRCLo << 8 |luc_CRCHi);
14. }

```

## Appendix 2: Parsing Code for Reference of Body Motion Sign Parameters

```
typedef union
{
    unsigned char
    Byte[4]; float Float;
}Float_Byte;

void main()
{
    Float_Byte fb;
    fb.Byte[0] = 0x9A;
    fb.Byte[1] = 0xFB;
    fb.Byte[2] = 0xE7;
    fb.Byte[3] = 0x3F;
    printf("%f\r\n",fb.Float);
}
```