



# 1.29 inch OLED Module Series

**GDMN0129RGWP30**

Dalian Good Display Co., Ltd.

# Product Specifications

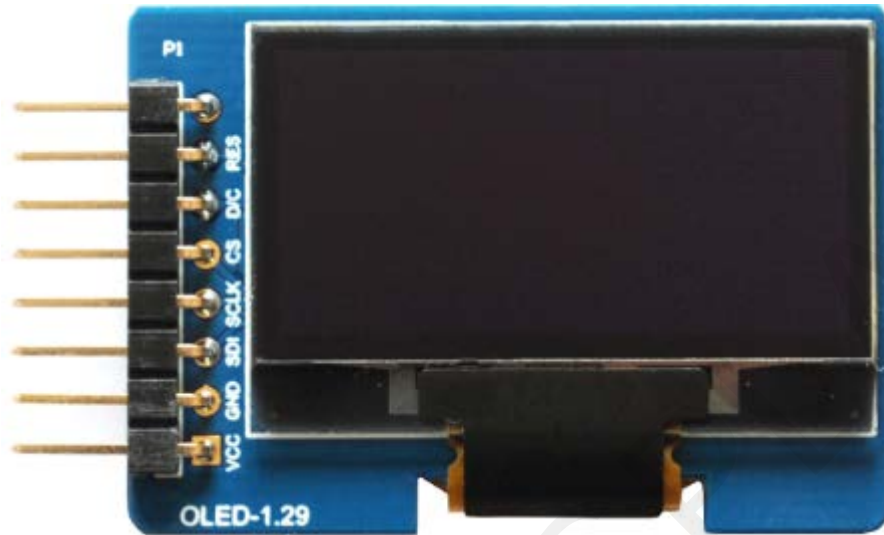

<b>Customer</b>	<b>Standard</b>
<b>Description</b>	<b>1.29" OLED MODULE</b>
<b>Model Name</b>	<b>GDMN0129RGWP30</b>
<b>Date</b>	<b>2020/06/19</b>
<b>Revision</b>	<b>1.0</b>

	Design Engineering		
	Approval	Check	Design
			

Zhongnan Building, No.18, Zhonghua West ST,Ganjingzi DST,Dalian,CHINA

Tel: +86-411-84619565 Fax: +86-411-84619585-810

Email: [info@good-display.com](mailto:info@good-display.com)

Website: [www.good-display.com](http://www.good-display.com)

# Contents

<b>1. Picture .....</b>	<b>4</b>
<b>2. Specification.....</b>	<b>4</b>
2.1 Standard Parameters .....	4
2.2 Mechanical Parameters.....	4
2.3 Electrical Parameters .....	5
2.4 Optical Parameters .....	5
<b>3. Electrical Characteristcs.....</b>	<b>5</b>
3.1 Pin configuration, SPI Mode.....	5
3.2 Pin configuration, IICMode.....	5
3.3 Absolute Maximum Rating.....	6
3.4 Electrical Characteristics .....	6
3.5 Reference Circuit.....	6
<b>4. GDMN0129RGWP30 Instructions.....</b>	<b>7</b>
4.1 Communication mode switch.....	7
4.2 FPC Inerface of OLED display.....	7
4.3 Test Point.....	7
<b>5. Initialization.....</b>	<b>8</b>
5.1 Initialization code.....	8
<b>6. Common Problems .....</b>	<b>10</b>
6.1 Driver board doesn't boost.....	10
6.2 Display contrast is low .....	10

## 1. Picture

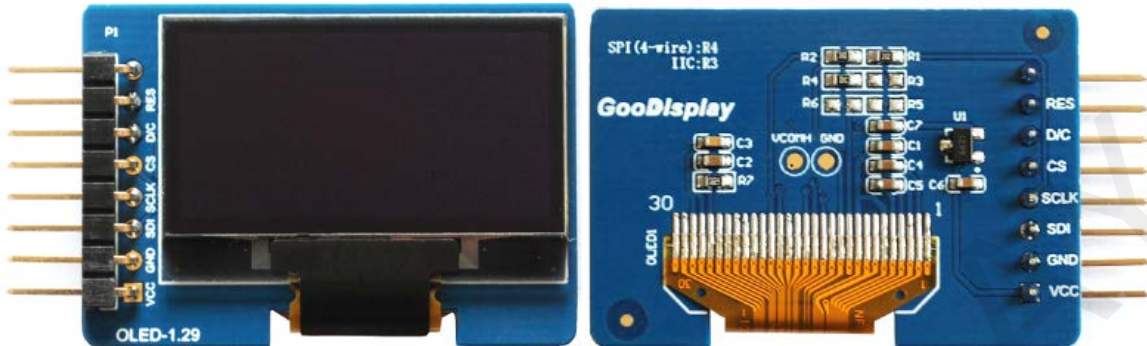

Pic. 01 GDMN0129RGWP30

## 2. Specification

### 2.1 Standard Parameters

Item	Standard Value	Unit
Display Format	128 x 64 Dots	--
Display Connector	Pin Header	--
Operating Temperature	-40 ~ +85	°C
Storage Temperature	-40 ~ +85	°C
Sunlight Readable	No	--

### 2.2 Mechanical Parameters

Item	Standard Value	Unit
Outline Dimension (PCB)	39.8(W)x27.8(H)	mm
Visual Area (OLED)	32.42(W)x21.36(H)x1.42(T)	mm
Active Area	29.42(W)x14.7(H)	mm
Dot Size	0.21x0.21	mm
Dot Pitch	0.23x0.23	mm

## 2.3 Electrical Parameters

Item	Standard Value	Unit
IC Package	COG	--
Controller	SSD1315	--
Interface	I2C & SPI	

## 2.4 Optical Parameters

Item	Standard Value	Unit
Display Type	OLED (Passive Matrix)	--
Viewing Angle Range	180	degree
OLED Duty	1/64	--

## 3. Electrical Characteristics

### 3.1 Pin configuration, SPI Mode

Pin No.	Pin Name	Description
1	VCC	Positive voltage supply
2	GND	Ground
3	SDA	Serial data input
4	SCL	Serial clock input.
5	CS	This pin is the chip select input. The chip is enabled for MCU communication only when CS# is pulled low.
6	DC	This pin is Data/Command control pin.
7	RES	This pin is reset signal input. When the pin is low, initialization of the chip is executed. Keep this pin pull high during normal operation.

### 3.2 Pin configuration, IICMode

Pin No.	Pin Name	Description
1	VCC	Positive voltage supply
2	GND	Ground
3	SDA	Serial data input/output with I2C interface.
4	SCL	Serial clock input with I2C interface.



### 3.3 Absolute Maximum Rating

Item	Symbol	Min.	Max.	Unit
Supply Voltage for Logic	VDD	-0.3	+4	V
Operating Temperature	Top	-40	+85	°C
Storage Temperature	Tstg	-40	+85	°C

### 3.4 Electrical Characteristics

Item	Symbol	Condition	Min.	Typ.	Max.	Unit
Supply Voltage for Logic	VDD	External supply	1.65	2.8	3.3	V
Supply Voltage for Logic IO	VDDIO	Internal supply	3.0	--	3.3	V
High Level Input	VIH	-	0.8xVDDIO	--	VDDIO	V
Low Level Input	VIL	-	0	--	0.2xVDDIO	V
High Level Output	VOH	IOUT=100uA, 3.3MHZ	0.9x VDDIO	--	VDDIO	V
Low Level Output	VOL	IOUT=100uA, 3.3MHZ	0	--	0.1xVDDIO	V
Operating Current for VDD	IDD	Note 5	--	41.0	46.0	mA
Sleep Mode Current for VDD	IDD,Sleep	--	--	-	10	uA

### 3.5 Reference Circuit

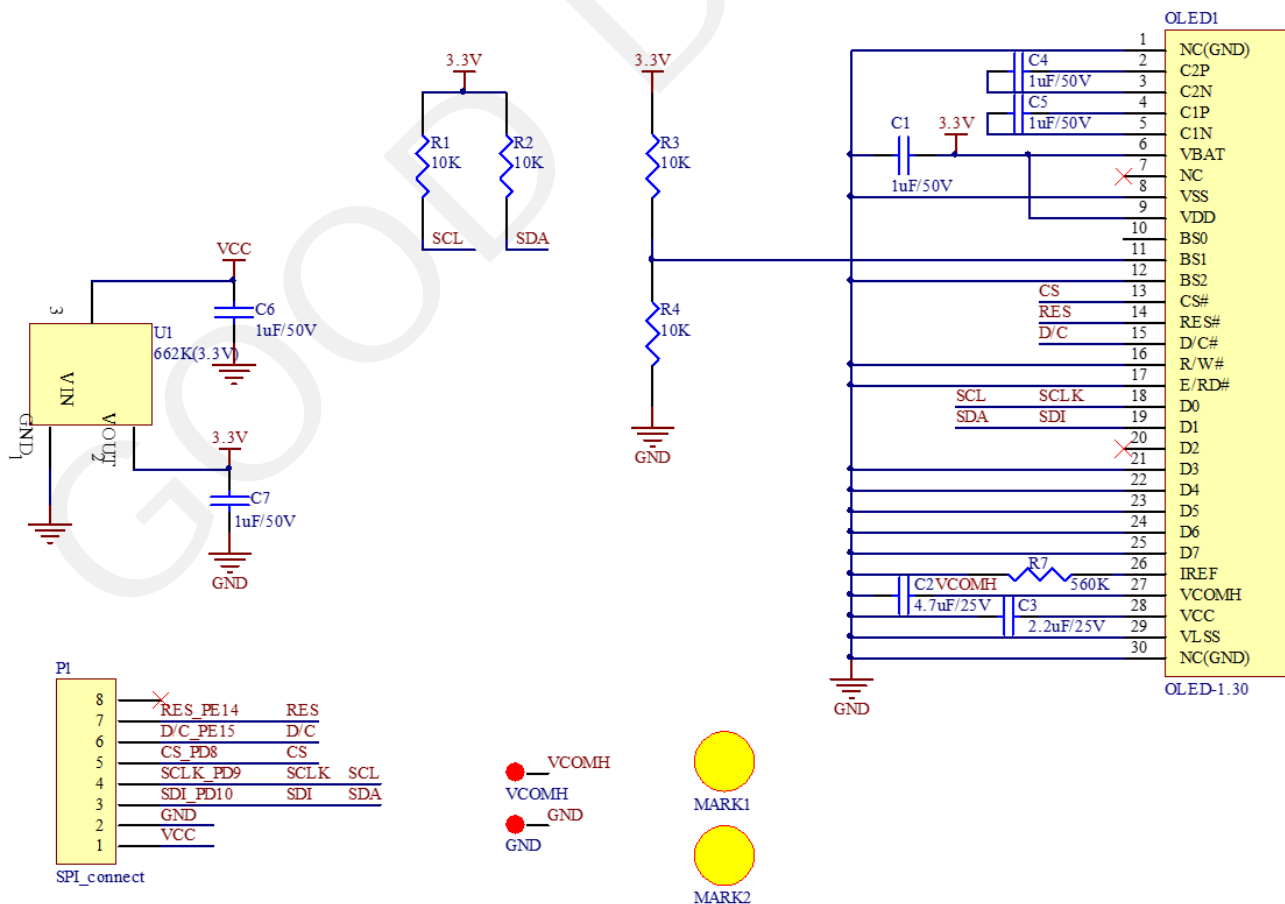

## 4. GDMN0129RGWP30 Instructions

### 4.1 Communication mode switch

Different interface mode need the different resistors matched, the OLED display would not display exactly if these resistors aren't matched correctly.

1) 4-wire SPI Mode

Welding R4

2) IIC Mode

Welding R3

### 4.2 FPC Interface of OLED display

The OLED display is connected to the adapter board through this interface. Pay attention to the corresponding pin labels when welding.

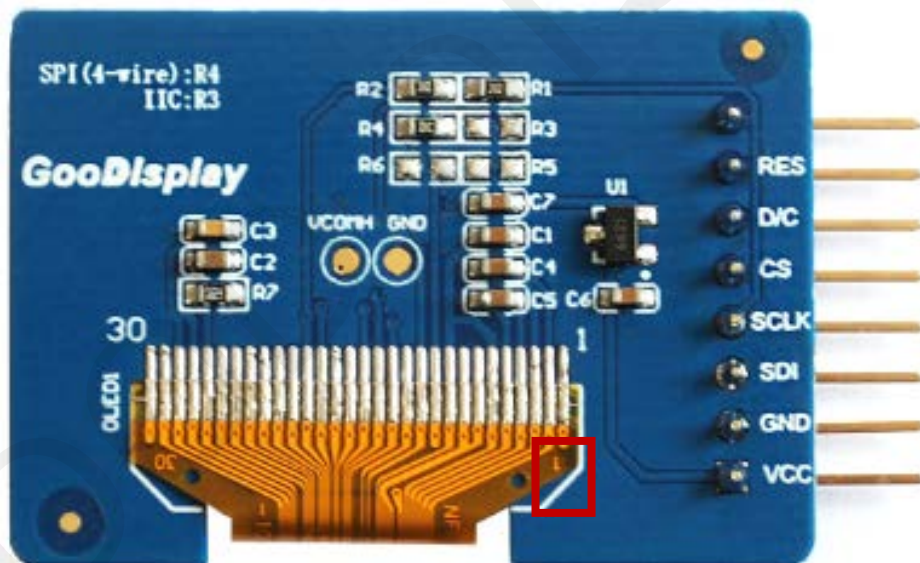

Pic. 02 OLED Display Welding

### 4.3 Test Point

This adapter board has a voltage test point VCOMH, the function is as follows:

1) VCOMH: OLED internal boost detection (It can detect the working status of IC).

## 5. Initialization

### 5.1 Initialization code

```
OLED_RST_Set();
delay_ms(100);
OLED_RST_Clr();
delay_ms(200);
OLED_RST_Set();
OLED_WR_Byte(0xAE,OLED_CMD);/--turn off oled panel
OLED_WR_Byte(0x00,OLED_CMD);/---set low column address
OLED_WR_Byte(0x10,OLED_CMD);/---set high column address
OLED_WR_Byte(0x40,OLED_CMD);/--set start line address Set Mapping RAM Display
Start Line (0x00~0x3F)
OLED_WR_Byte(0x81,OLED_CMD);/--set contrast control register
OLED_WR_Byte(0xCF,OLED_CMD); // Set SEG Output Current Brightness
OLED_WR_Byte(0xA1,OLED_CMD);/--Set SEG/Column Mapping 0xa0 Left and Right
reverse 0xa1 normal
OLED_WR_Byte(0xC8,OLED_CMD);//Set COM/Row Scan Direction 0xc0 Up and Down
reverse 0xc8 normal
OLED_WR_Byte(0xA6,OLED_CMD);/--set normal display
OLED_WR_Byte(0xA8,OLED_CMD);/--set multiplex ratio(1 to 64)
OLED_WR_Byte(0x3f,OLED_CMD);/--1/64 duty
OLED_WR_Byte(0xD3,OLED_CMD);/--set display offset Shift Mapping RAM Counter
(0x00~0x3F)
OLED_WR_Byte(0x00,OLED_CMD);/--not offset
OLED_WR_Byte(0xd5,OLED_CMD);/--set display clock divide ratio/oscillator frequency
OLED_WR_Byte(0x80,OLED_CMD);/--set divide ratio, Set Clock as 100 Frames/Sec
OLED_WR_Byte(0xD9,OLED_CMD);/--set pre-charge period
OLED_WR_Byte(0xF1,OLED_CMD);//Set Pre-Charge as 15 Clocks & Discharge as 1 Clock
OLED_WR_Byte(0xDA,OLED_CMD);/--set com pins hardware configuration
OLED_WR_Byte(0x12,OLED_CMD);
OLED_WR_Byte(0xDB,OLED_CMD);/--set vcomh
OLED_WR_Byte(0x40,OLED_CMD);//Set VCOM Deselect Level
```



```
OLED_WR_Byte(0x20,OLED_CMD);//-Set Page Addressing Mode (0x00/0x01/0x02)
OLED_WR_Byte(0x02,OLED_CMD);//
OLED_WR_Byte(0x8D,OLED_CMD);/--set Charge Pump enable/disable
OLED_WR_Byte(0x14,OLED_CMD);/--set(0x10) disable
OLED_WR_Byte(0xA4,OLED_CMD);// Disable Entire Display On (0xa4/0xa5)
OLED_WR_Byte(0xA6,OLED_CMD);// Disable Inverse Display On (0xa6/a7)
OLED_WR_Byte(0xAF,OLED_CMD);/--turn on oled panel
OLED_WR_Byte(0xAF,OLED_CMD); /*display ON*/
```

## 6. Common Problems

### 6.1 Driver board doesn't generate boost voltage.

- 1) The communication mode is selected incorrectly. Users could switch the welding position according to the corresponding communication mode.
- 2) When the user transplants the module, the IO port doesn't correspond to the module one by one, resulting in communication failure.

### 6.2 Display contrast is low

The contrast can be adjusted by software. If the default resistance value of contrast isn't suitable, it will also affect the display effect.

GOOD DISPLAY