



PRECISION STRAIN WAVE GEAR REDUCER

精密谐波齿轮减速器

ZD[®] 中大力德

谐波传动原理 MECHANISM OF STRAIN WAVE GEAR DRIVE

谐波齿轮传动是美国天才发明家C.W.Musser于1957年发明创造的。它通过控制柔性构件的弹性变形实现了运动和动力的传递，颠覆了传统齿轮传动的常识因而备受瞩目。

Strain wave gear drive is a concept which was introduced in a 1957 patent of C.W. Musser , a genius inventor in U.S., It achieves the motion transmission by controlling the deflection of metal, which has demolished the conventional sense of gear transmission.

■ 谐波传动装置的构成 Composition of strain wave gear transmission device

谐波传动装置主要由三个基本零部件构成，即波发生器、柔轮和刚轮，因此更加满足小型化和轻量化的需求。

The strain wave gear device is mainly composed of three basic parts, namely, wave generator, flexspline and circular spline. It can better meet the needs of miniaturization and lightweight.



- **波发生器**：是柔性薄壁滚珠轴承与椭圆状的凸轮组装而成的部件。轴承内环在凸轮上涨紧，外环经过滚珠的支撑产生弹性变形。波发生器一般安装在输入轴上。

Wave Generator: The wave generator is a thin raced ball bearing fitted onto an elliptical hub serving as a high efficiency torque converter and generally mounted onto the input shaft.

- **柔轮**：是具有薄壁杯状或礼帽状的薄壁零件。在开口端滚制轮齿，底部是隔板。柔轮通常安装在输出轴上。

Flexspline: The Flexspline is a flexible, thin cylindrical cup with external teeth. The bottom of flexspline is called diaphragm and generally mounted onto the output shaft.

- **刚轮**：是刚性环状内齿轮，一般比柔轮多两个齿，通常被固定在机壳上。

Circular Spline: The circular spline is a rigid ring with internal teeth, engaging the teeth of the flexspline across the major axis of the Wave Generator. The circular spline has two more teeth than the flexspline and is generally mounted onto housing.

■ 谐波减速机原理 Transmission principle of Strain wave gear

当波发生器装入柔轮时，迫使柔轮产生弹性变形并呈椭圆形状，在长轴附近柔轮轮齿插入刚轮齿槽内，呈完全啮合状；而处于短轴附近的刚轮、柔轮轮齿完全不接触，处于脱开状态。由啮合到脱开的过程之间则处于啮入与啮出状态。当波发生器连续转动时，迫使柔轮产生周期性变形，两轮轮齿在啮入、啮合、啮出、脱开的过程中不断循环工作状态，产生了错齿运动，从而实现波发生器与柔轮或刚轮之间的运动传递。

When the wave generator is assembled into the flexspline, the flexspline will be deformed elastically into an elliptical shape. The flexspline teeth near the major axis are inserted into the cogging of the circular spline in a complete meshing state, while the teeth of the splines near the minor axis are completely in a detached state. The process between engaged and detached are the states of meshing-in and meshing-out. As the wave generator rotates, the flexspline is deformed continuously and periodically making the teeth circling in the process of "meshing-in, fully engaged, meshing-out, and detached", thus, has realized the transmission between the wave generator and the splines.

虽然谐波齿轮传动也可以做增速传动，但大部分情况下是用作减速机。这时波发生器是主动件（输入端），当刚轮固定时，柔轮通过隔片连接输出端转动；当柔轮隔片固定时，刚轮连接输出端转动。

Although strain wave gear drive can also be used as accelerator, in most cases it is used as a reducer with the wave generator as the active member (input). When the circular spline is fixed, the flexspline is the output part; on the other hand, the circular spline will be the output part.

传动过程如下： The following is the transmission process:

柔轮在波发生器的作用下产生椭圆状变形，并因此在长轴部位上柔轮与刚轮齿互相啮合；但在短轴部位上，两轮的轮齿是呈完全分开的状态。

While the flexspline is being deformed by the wave generator, the teeth of the flexspline and circular spline engaging with each other at the major axis part and disengaging at the minor axis part.

固定刚轮并使波发生器顺时针旋转，柔轮产生弹性变形并逐渐移动至能够和刚轮齿槽啮合的位置。

As the wave generator rotates in clockwise while the circular spline is fixed, the flexspline elastically is being deformed and the engaging points of the teeth shifting sequentially.

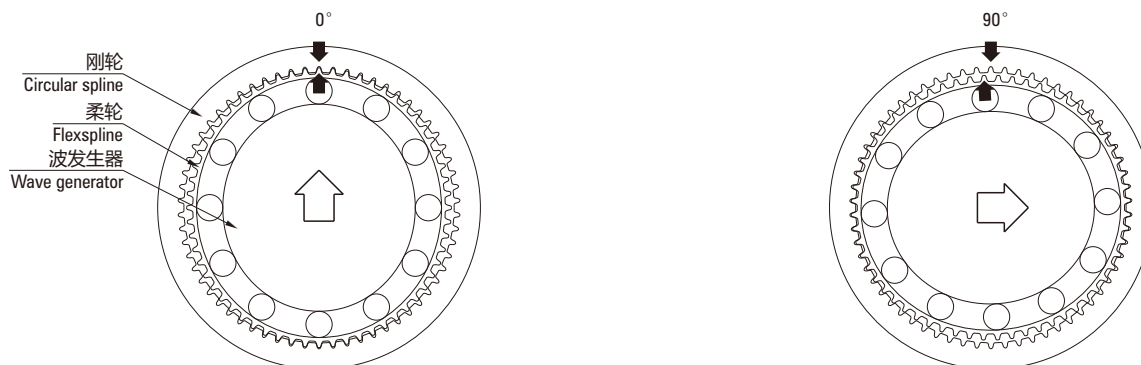

当波发生器顺时针旋转180°后，柔轮会逆时针转动一个齿距。

For every 180° clockwise movement of the wave generator, the flexspline moves in counterclockwise by one tooth.

因为柔轮齿数比刚轮少2，因此当波发生器旋转1圈（360°）后，柔轮会逆时针转动2个齿距。一般将此动作作为输出进行利用。

When the wave generator rotates through one turn (360°), accordingly the flexspline will move in counterclockwise by two teeth for the difference of two teeth number between flexspline and the circular spline. Generally, this movement is taken as output.



谐波传动的特点 Characteristics of strain wave gear transmission

- 精度高：**很多齿同时啮合，因此谐波齿轮的齿距误差和累积齿距误差对传动精度的影响比较平均，可得到极高的传动精度。
 High Precision: The multi-tooth is meshing at the two positions which are 180° from each other at the same time, so that the influences on transmission accuracy due to gear pitch error and the cumulative pitch error can be balanced and reach to extremely high transmission accuracy.
- 传动比大：**单级谐波齿轮传动速比可达30~500。
 Transmission ratio: a single-stage strain wave gear transmission ratio can reach to 30~500.
- 承载能力高：**谐波齿轮传动中，齿与齿的啮合面积大，并且同时啮合的齿数多，因而单位面积载荷小，可以承载较大的扭矩。
 Load carrying capacity: the meshing area as well as the number of teeth at engage stage is large, so load which is divided on each tooth, could be smaller accordingly, while the overall load could be very large.
- 体积小、重量轻：**相比普通的齿轮传动，体积和重量大幅度降低，具有小型化和轻量化的特征。
 Size & weight: comparing with the conventional gear device, it has the features of miniaturization and light-weight.
- 传动效率高：**谐波减速器的传动效率可达70%~85%。
 Transmission efficiency: the transmission efficiency of strain wave gear reducer can reach to 70%~85%.
- 传动平稳、无冲击、噪音小。**
 Smooth gearing, non-impact, and lower noise.

型号命名 SERIES NAMING

Z SHF — 32 — 120 — 2UH — AB — 002
 ① ② ③ ④ ⑤ ⑥ ⑦

减速器参数 Gearbox Specifications	①	中大德 Zhongda Leader	
	②	柔轮结构型式 Structure of Flexspline: SHF: 标准礼帽型 Standard Hat Type SHD: 短筒礼帽型 Super Flat Hat Type CSG: 高转矩杯型 High-torque Cup Type	SHG: 高转矩型礼帽型 High-torque Hat Type CSF: 标准杯型 Standard Cup Type CSD: 超扁平杯型 Super Flat Cup Type
	③	型号代号 Model Code 目前型号有: 14, 17, 20, 25, 32五种, 该值乘以2.54近似等于对应型号减速机节圆直径数值。 There are 5 Models: 14, 17, 20, 25, 32. The code value multiplied by 2.54 is approximately equal to the diameter of the corresponding type of reducer.	
	④	速比值 Reduction Ratio 各型号速比数值有50, 80, 100, 120四种。Currently there are four ratios: 1:50, 1: 80, 1:100, 1:120.	
	⑤	结构型式 Structures of Reducer 2UH: 标准组合型 Standard Unit Type 2UJ: 输入轴组合型 Shaft Input Type 2UF: 中空扁平组合型 Flat Hollow Shaft Type	2SO: 简易组合扁平型 Flat Type 2SH: 简易组合中空型 Flat Hollow Shaft Type
	⑥	客户代号 Customer Code	
	⑦	流水号 Serial number	

举例 For example:

ZSHF-25-100-2SH: 中大谐波减速机, 25系列标准礼帽型, 100速比, 简易组合中空型产品。

ZSHF-25-100-2SH: Zhongda Leader made strain wave reducer, Standard Hat type of 25 size, reduction ratio 1:100, flat hollow shaft type.

产品家族 Series

结构 Type	名称 Name	型号 Model	额定转矩 (Nm) Rated Torque	减速比 Reduction Ratio
组合型 Unit Type	标准型 Standard Type	CSF-2UH	5.4~137	50, 80, 100, 120, 160
	高转矩型 High-torque Type	CSG-2UH	7~178	
	中空轴型 Hollow Shaft Type	SHF-2UH	5.4~137	
	高转矩中空轴型 High-torque Hollow Shaft Type	SHG-2UH	7~178	
	输入轴型 Shaft Input Type	SHF-2UJ	5.4~137	
	高转矩输入轴型 High-torque Shaft Input Type	SHG-2UJ	7~178	
	超薄型 Super Flat Type	CSD-2UH	3.7~96	
	超薄中空轴型 Super Flat Hollow Shaft Type	CSD-2UF	3.7~96	
简易组合型 Simple Unit Type	扁平中空轴型 Flat Hollow Shaft Type	SHF-2SH	5.4~137	
	扁平型 Flat Type	SHF-2SO	5.4~137	
	高转矩扁平中空轴型 High-torque Flat Hollow Shaft Type	SHG-2SH	7~178	
	高转矩扁平型 High-torque Flat Type	SHG-2SO	7~178	
	超扁平中空轴型 Super Flat Hollow Shaft Type	SHD-2SH	3.7~96	



ZCSG-2UH / CSF-2UH

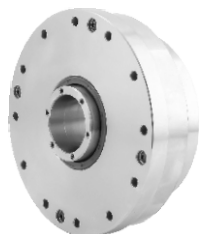

ZSHG-2UH / SHF-2UH



ZSHG-2UJ / SHF-2UJ



ZSHG-2SO / SHF-2SO



ZSHD-2SH

术语与定义 TERMS AND DEFINITIONS

● 迟滞曲线 Hysteresis curve

固定输入端（波发生器），向输出端（柔轮或刚轮）施加负载转矩。当负载转矩完成 $[0] - [+T_0] - [0] - [-T_0] - [0] - [+T_0]$ 的加载回路时，可以得到转矩与扭转角的对应关系，绘制出迟滞曲线如图1所示。

Fixing the input side (wave generator) and applying torque to the output side (flexspline or circular spline) and we can get the torsion which is almost proportional to the torque on the output side. Figure 1 shows the torsional angle quantity on the output side when the torque is applied on the output side starting from zero, increases up to $+T_0$ (the rated torque) and decreases down to $-T_0$. This is called "Torque - torsional angle diagram", e.g., "Hysteresis curve" which normally is a loop of $[0] - [+T_0] - [0] - [-T_0] - [0] - [+T_0]$.

● 回程误差 Lost motion

在额定转矩的 $\pm 4\%$ 位置处迟滞曲线宽度中点的扭转角差值（图1）。It is the torsion angle difference at the midpoint of the width $\pm 4\%$ in the hysteresis curve when it is under the rated torque (Fig.1).

● 扭转刚度 Torsional rigidity

扭转刚度=B/A

Torsional rigidity=B/A

K1、K2、K3分别对应不同负载阶段的扭转刚度，详细见各型号的额定参数表。

K1, K2 and K3 respectively correspond to the torsional rigidity of different loads, refer to table of rated specifications of each model.



图1-迟滞曲线 Hysteresis curve

● 传动精度(θ) Transmission accuracy (θ)

输入任意旋转角时，理论输出转角与实际输出转角的差值，即： $\theta = \theta_{in} / k - \theta_{out}$ ，其中k为速比。

Transmission accuracy indicates the difference between the theoretical rotating angle and the actual rotating angle as the transmission error when any rotating angle is given as an input. $\theta = \theta_{in} / k - \theta_{out}$, in which k represents the reduction ratio.

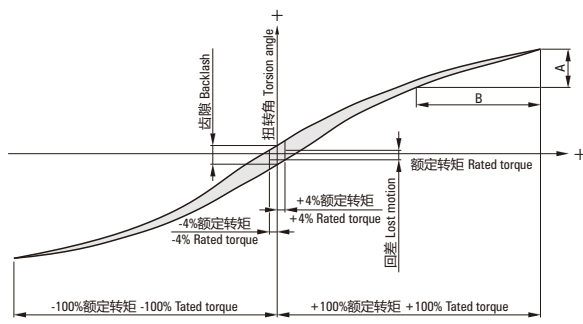
● 齿隙 Backlash

扭转角在转矩为零位置处的差值（图1）。It is the torsion angle difference when the torque is zero (Fig. 1).

● 启动扭矩 Starting torque

减速机空载启动所需要的在输入端施加的最小转矩。Starting torque means the instantaneous "starting torque" with which the output side (low-speed side) starts rotating when a torque is applied on the input side (high-speed side) of strain wave gear reducer.

● 额定输出转矩 Rated torque

减速机能够在保持稳定工作性能的前提下，在2000r/m能长时间运行的输出转矩。

The permissible continuous output load torque when the input rotational speed is 2000 rpm under the circumstance of stable running of the gearbox.

● 容许最大平均负载转矩 Permissible maximum value of average load torque

谐波减速机能够长时间工作的最大转矩。When the load torque and input rotational speed change, the average value of the load torque needs to be reached. If the average load torque exceeds the permissible value, generated heat will degrade the life of lubricant earlier and leads to the acceleration of teeth abrasion.

● 容许最大/平均输入转速

Permissible maximum & average input rotational speed

谐波减速机允许的输入转速的最大值和平均值。The limit of permissible values of input rotational speed for a strain wave gearbox.

● 容许最大瞬时转矩 Permissible maximum momentary torque

能够短时间承受的最大转矩。Unexpected impact torque may be applied from outside except the "regular" load torque and load torque of starting and stopping. The maximum value of the impact torque must not exceed the permissible maximum momentary torque.

● 启动停止时的容许转矩峰值 Permissible peak torque for start and stop

启动停止瞬间，谐波减速机所允许的最大冲击转矩。The acceptable peak torque of strain wave gear reducer when it starts or stops.

谐波减速机的选型 HOW TO SELECT

首先需要掌握负载转矩的特性，确认输出转速和负载转矩的时变特征。然后进行如下计算选型流程：

First, the time-varying characteristics of output speed and load torque need to be confirmed. Then select a model by following the steps below:

- 根据负载转矩特性计算出减速机输出侧的平均负载 T_{av} :

Calculate the average load torque T_{av} (N·m) applied on the output side of strain wave reducer according to the load torque characteristics :

负载单位: Nm, 转速单位: RPM, 时间单位: s

Load Unit: Nm, Rotational Speed Unit: r/min, Time Unit: s

$$T_{av} = \sqrt[3]{\frac{n_1 t_1 |T_1|^3 + n_2 t_2 |T_2|^3 + \dots + n_n t_n |T_n|^3}{n_1 t_1 + n_2 t_2 + \dots + n_n t_n}}$$

- 根据平均负载转矩，参照各系列产品额定参数暂时选定型号:
Temporarily select a model based on the following conditions:

$$T_{av} \leq \begin{array}{l} \text{平均负载转矩的容许最大值} \\ \text{Permissible maximum value of the average load torque} \end{array}$$

- 计算平均输出转速 n_{out} (r/min):

Calculate the average output rotational speed: n_{out} (r/min):

$$n_{out} = \frac{n_1 t_1 + n_2 t_2 + \dots + n_n t_n}{t_1 + t_2 + \dots + t_n}$$

- 确定减速比:

Confirm the reduction ratio:

$$i \leq \frac{n_{in \max}}{n_{out \max}}$$

$n_{in \max}$ 为根据电动机进行选择的参数。

A limit is placed on " $n_{in \max}$ " by motors.

- 根据平均输出转速和减速比计算出平均输入转速 n_{in} :

Calculate the average input rotational speed (n_{in}) according to the average output rotational speed (n_{out}) and the reduction ratio i as below:

$$n_{in} = n_{out} i$$

- 根据最高输出转速和减速比计算出最高输入转速:

Calculate the maximum input rotational speed ($n_{in \max}$) according to the max. output rotational speed ($n_{out \max}$) and the reduction ratio as below:

$$n_{in \max} = n_{out \max} i$$

- 检查暂选型号是否满足如下要求:

Check whether the temporarily selected model can satisfy the following condition or not:

- 确认平均输入转速 $n_{in} \leq$ 容许平均输入转速 ;
Check whether the average input rotational speed is equal to or less than the Permissible average input rotational speed (r/min).
- 确认 T_1 、 T_3 是否处于额定启动停止时的容许峰值转矩以内 ;
Check whether T_1 and T_3 are equal to or less than the permissible peak torque (N·m) at the state of starting and stopping (rated).
- 确认冲击转矩 T_s 是否处于额定参数的瞬间容许最大转矩以内 ;
Check whether the impact torque T_s is equal to or less than the permissible maximum momentary torque (N·m) at the state of rated specifications.
- 根据施加冲击转矩时的输出转速 n_s 和时间 t_s ，计算出容许次数 N_s ，并确认是否符合使用条件，

$$\text{其中 } N_s = \frac{60 \times 10^4}{2n_s t_s} \quad \text{且 } [N_s] \leq 10^4 ;$$

Calculate (Ns) the permissible number of times based on the output rotational speed n_s and time t_s when the impact torque is applied, and check whether it can satisfy the usage conditions.

- 计算使用寿命是否满足要求 : Calculate the lifetime.

$$L_{10} = 7000 \left(\frac{T_r}{T_{av}} \right)^3 \left(\frac{n_{in}}{n_{in \max}} \right)$$

以上任一步骤的计算结果若超出额定参数表，均需要重新选择减速机型号。

If you find any of the values has exceeded the rated parameters, you should review it with the previous model or reconsider reduction ratio of conditions including the load torque.

谐波减速器使用说明 INSTRUCTIONS

谐波减速机有组合型、简易组合型等结构型式，不同的结构型式对应不同的波发生器结构与使用方式。

We have unit type, simple unit type and the other structural types of strain wave reducer, different types correspond to different structures of wave generators.

波发生器结构型式 Structures of Wave Generator

● 欧式联轴节型波发生器 Oldham's coupling type

欧式联轴节型波发生器由轮毂、凸轮、柔性轴承、卡簧、垫圈以及十字滑块等构件组成（如下图），可实现一定范围内的自动调心，一定程度上能够降低安装要求，保证传动精度。该波发生器需要用户自行组装至传动组件，具体装配注意事项请见下文。

The wave generator of Oldham's coupling type is composed of a hub, a plug, a flexible bearing, a C-type retaining ring, a rub-washer, and a cross slide insert (see below). It can reduce the installation requirements to a certain extent and ensure the transmission accuracy for its self-aligning structure. This wave generator needs to be assembled into the transmission component by the user. Please refer to the following details for assembly instructions.

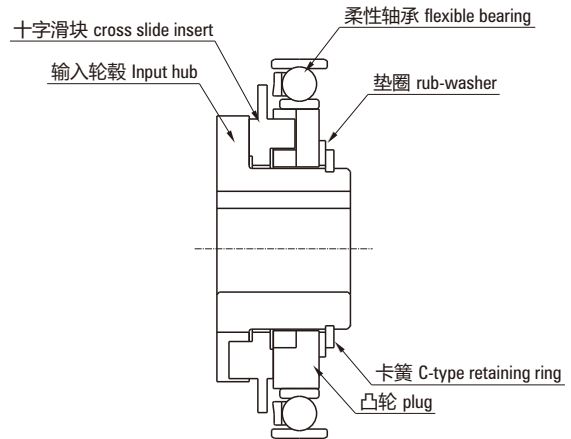

● 中空轴式波发生器 Hollow shaft type

中空轴式波发生器的输入轴为中空凸轮轴，凸轮部分由数控机床加工成形，属于一体式结构，该结构波发生器已准确安装在减速机中，用户可直接使用。

The hollow shaft type wave generator has a hollow shaft with a cam on it. The hollow cam shaft is processed by a CNC machine and it has an integrated structure. This wave generator has been accurately installed on the reducer so that users can use it directly.

● 一体式波发生器 Integrated rigid type

一体式波发生器无调心结构，用户需要自行组装波发生器组件与传动组件。如下图所示，波发生器在结构上更加简便，但对安装精度的要求较高，详情请参照各系列的外形图。

The integrated rigid type wave generator has no self-aligning structure, therefore users need to assemble the wave generator and transmission components. As shown in the figure below, the wave generator is simpler in structure, but it requires higher installation accuracy. For details, please refer to the outline drawing of each series.

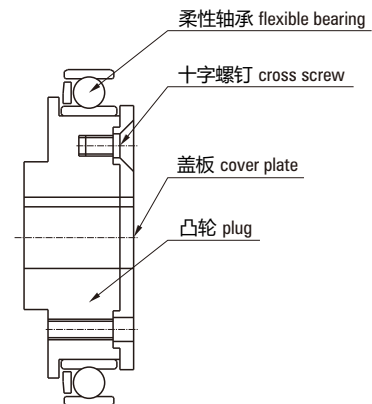

● 波发生器的轴向力 Thrust force of wave generator

由于柔轮的弹性变形，运转过程中会产生对波发生器组件的轴向力。

Thrust force is applied on the wave generator during operation due to elastic deformation of the flexspline on the running of gearbox.

该力的方向为：

当作为减速器使用时，该力指向柔轮杯底；

当作为增速器使用时，该力指向柔轮杯口。

As a reducer, the thrust force is applied to the diaphragm direction of the flexspline, while as an increaser, the thrust force is applied to the cup edge direction of flexspline.

因此应当采取措施以平衡此力，阻止波发生器的轴向位移。

Therefore, it is necessary to work out a design to eliminate the thrust force of the wave generator in either case. through the internal structure, while the separate type will need other structure to offset the force.

● 波发生器固定方式 Fix mode of wave generator

为平衡轴向力，保证谐波减速机正常工作，需采取措施对波发生器组件进行轴向锁紧。通常采用的锁紧措施为轴端螺钉固定、隔圈固定和紧定螺钉固定，其结构型式分别如下。（图2）

In order to balance the thrust force and ensure the regular operation of the strain wave reducer, it is necessary to take measures to lock the wave generator components axially. The commonly used locking measurement are fixation of shaft end with a screw, spacer fixation and set screw fixation. Check the followings for their structural types. (Fig.2)

轴端螺钉固定适用于输入轴有轴肩、定位精度较高并且可以与波发生器组件直接连接的情况。

The way to fix the shaft end with a screw, is suitable for the case that there is a shaft shoulder at the input shaft and with high positioning accuracy, furthermore, it can be directly connected with the wave generator components.

隔圈式固定适用于输入轴轴肩过长的情况，即在轴上加一个隔圈（端面平行度0.01mm以内）之后，再与波发生器联结固定：（图3）

The way of spacer fixation is suitable for the case that input shaft shoulder is too long, that is, a spacer is need to be added on the shaft (parallelism of the end is less than 0.01mm), and then fixes it with the wave generator: (Fig.3)

紧定螺钉固定适用于小负载光轴输入型式，通过波发生器组件上的紧定螺钉与输入轴连接固定：（图4）

The way of set screw fixation is suitable for the case of shaft only input type and with light load. It is fixed by connecting the input shaft with the set screw on the wave generator: (Fig.4)

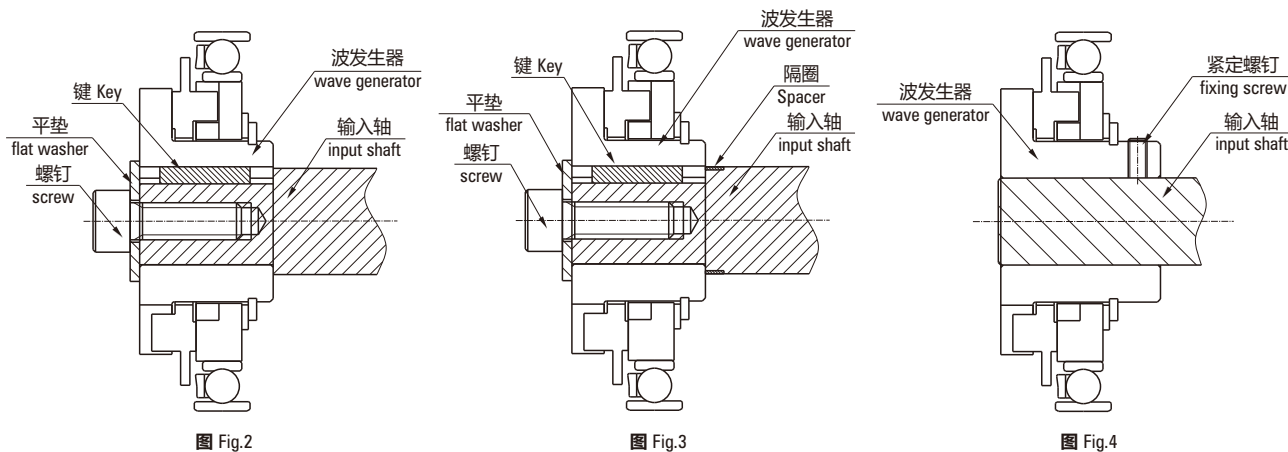

■ 设计指南 Design guideline

● 安装步骤 Mounting Steps

为充分发挥谐波减速器的使用性能，请注意以下几点：

Pay attention to the following points to fully bring out the performance of a strain wave reducer.

- 将输入轴、刚轮、输出轴以及壳体设为同心，输入轴和输出轴应有可承受轴上作动的的所有径向负载、轴向负载的结构；
The input shaft, the circular spline, the output shaft and the case should be concentric. The input shaft and the output shaft should be able to withstand all the radial load and axial load on the shaft.
- 波发生器会产生轴向力，输入轴应设计为能够平衡此力的结构；
As thrust force is generated by the wave generator, input shaft should be structured to balance the force.
- 谐波减速器是一种功率密度较高的传动装置，因此应对连接柔轮和输出轴的螺栓采取相适应的拧紧转矩进行紧固；
The strain wave reducer has high power density. Therefore, the joining bolt connecting the flexspline and the output shaft should be fixed with proper tightening torque.
- 柔轮会发生弹性形变，因此壳体内壁尺寸应按照推荐尺寸设计；
As the flexspline deforms elastically, the inner wall of the housing should be made according to the recommended size.
- 确保柔轮的安装法兰直径不会超过柔轮的凸台直径；
The mounting flange diameter of the flexspline shall not exceed the boss diameter of the flexspline. Attach "R" on the flange which is in contact with the diaphragm. Use the recommended size for parts.
- 使用C型卡环固定波发生器轮毂，应确保卡环不会与壳体接触。
Use C-type retaining ring to fix the hub of the wave generator to make sure that the hook of the retaining ring shall not interface with the housing.

谐波减速机安装步骤与注意事项 INSTALLATION STEPS AND PRECAUTIONS

■ 安装步骤 Installation steps

对组合型波发生器和一体式波发生器需要按照以下步骤进行安装：

Following the steps below to install the unit type and integrated rigid wave generator:

- 将传动组件安装至机架； Install the gear part to the housing.
- 将波发生器组件安装至输入轴； Install the wave generator onto the input shaft.
- 将波发生器组件旋入传动组件。 Rotate the wave generator and install it into the gear part.

■ 安装示意图如下 Refer to installation diagram below

● 杯型柔轮（CSF型）：Cup type Flexspline (CSF Model)

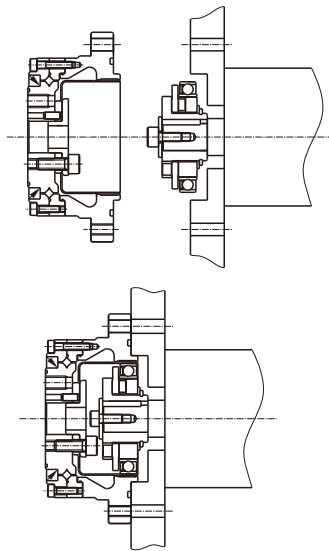

● 礼帽型柔轮（SHF型）：Hat type flexspline (SHF Model)

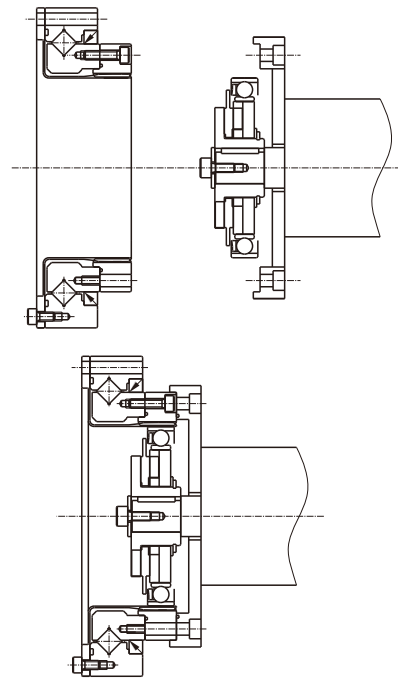

■ 注意事项 Cautions

为避免装配的错误而使谐波减速机在运转过程中产生振动、异响，在组装时应严格遵守下述注意事项：

In order to avoid mounting error which could cause the vibration and abnormal sound of strain wave gear reducer during operation, please pay high attention to the following precautions:

- 谐波减速机应在足够清洁的环境下组装，不允许有任何异物进入减速机内部；
The strain wave gear reducer should be in a clean environment, and no foreign matter is allowed to enter the interior of the reducer during assembling.
- 波发生器组件与传动组件组装时，应避免向柔性轴承部位施加过大的力，应使波发生器缓慢旋转，并施加轴向压力缓缓压入柔轮中；
Avoid such assembly where excessive force is applied to the wave generator bearing. The wave generator should be smoothly inserted while rotating it in.
- 传动组件与机架联结时，应注意配合端面的洁净，确认安装面的平整度及倾斜度是否在要求范围内；
It should be aware the cleanliness of the mating surface and confirmed if the values of flatness and inclination of the mounting surface are within their required range when assembling the transmission components with the frame.
- 确认螺钉孔部是否有隆起、毛边或异物；
Check if there are any embossment, burr or foreign matter near the screw hole area.
- 确认螺栓孔位置是否正确、是否歪斜，安装螺栓时不可一次性拧紧，应先使用约一半规定转矩的力以十字交叉的方式实施暂时拧紧，然后再按照规定转矩拧紧；
Do not tighten the bolts with the specified torque all at once. Tighten the bolts temporarily with about half of the specified torque, and then tighten then with the specified torque. Tighten then in an even, crisscross pattern. But before the tightening, the evenness and its position must be checked.
- 确认是否对壳体组装部实施了倒角以及避让加工；
Check whether chamfering and relief working of the corner have been conducted in order to prevent the interference of the corner of the circular spline in the house built-in area.

- 将刚轮与机架组装后，确认其是否能够旋转，是否有卡点、干涉等；
Check if the circular spline can rotate or if it interferes with each other or catch on any part after the assembling of circular spline and frame.
- 确认柔轮与刚轮组合时，是否存在极端的单侧啮合现象；
Check the flexspline whether it engages with the circular spline in an extremely unbalanced way when it is combined. If it is unbalanced, they could be misaligned or not upright.
- 为充分发挥谐波减速机的性能，请确保如下所示的安装精度。
Ensure the recommended precision shown in the Figure below to fully bring out the excellent performance of strain wave gear reducer.

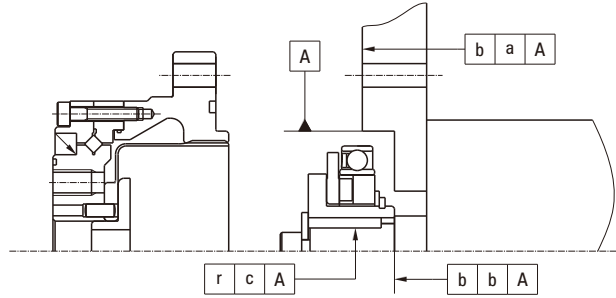

型号 Model	14	17	20	25	32
a	0.011	0.015	0.017	0.024	0.026
b	0.017	0.020	0.020	0.024	0.024
	(0.008)	(0.010)	(0.010)	(0.012)	(0.012)
c	0.030	0.034	0.044	0.047	0.005
	(0.016)	(0.018)	(0.019)	(0.022)	(0.022)

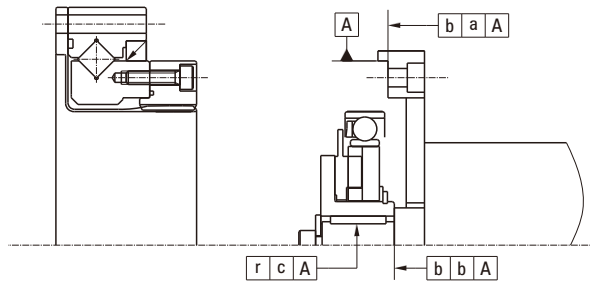

型号 Model	14	17	20	25	32
a	0.011	0.015	0.017	0.024	0.026
b	0.017	0.020	0.020	0.024	0.024
	(0.008)	(0.010)	(0.010)	(0.012)	(0.012)
c	0.030	0.034	0.044	0.047	0.005
	(0.016)	(0.018)	(0.019)	(0.022)	(0.022)

- b、c为十字滑块波发生器与一体式波发生器（括号内的数值）的参考值。
b, c are the reference values of different types of wave generator. The value in the parentheses indicates the rigid type of wave generator without Oldham's coupling structure.

谐波减速机的润滑方案 LUBRICATION OF STRAIN WAVE GEAR REDUCER

我司谐波减速机均采用润滑脂进行润滑。组合型结构的减速机出厂前已封入润滑脂，用户可直接使用无需另行加注。其余机型内部隐藏部分已封入润滑脂，但组装波发生器时仍需注入、涂抹润滑脂。

All of the strain wave gear reducers produced by ZD are grease lubricated and have been sealed with grease before it is leaving our factory. But it is still necessary to inject grease before assemble the wave generator with other gear components.

■ 使用润滑脂的注意事项 Cautions about lubrication:

- 谐波减速机的输入、输出端必须严格密封。动密封部位建议使用骨架式油封进行密封；静密封部位建议采用O型圈或密封橡胶进行密封，密封面不得有伤痕且不得有歪斜；
The input and output ends of the strain wave reducer must be strictly sealed. It is recommended to adopt the way of skeleton oil sealing to seal the dynamic parts and while use O-rings or sealing rubber for the static parts, and the sealing parts shall be free of scars and skew.
- 必须使用专用谐波减速机润滑脂，避免与其他润滑脂混用，推荐14，17型谐波减速机应用SK-2，润滑脂，20，25，32型谐波减速机应用SK-1A型润滑脂；
The specified grease for strain wave reducer must be used and avoiding the mixing with other greases. The grease of SK-2 is recommended for Model 14 and Model 17, and SK-1A is recommended for Model 20, 25, and 32.
- 润滑脂的使用方式须按照说明书要求使用，并严格遵守各型号减速机对润滑脂注入量和涂抹量的要求；
Grease shall be used in accordance with the requirements of the manual, and strictly comply with the requirements of models of reducers on the amount of grease injected.
- 谐波减速机在使用过程中，应尽量避免波发生器始终朝上或单向低速的工作状态，否则可能会引起润滑不良，此时应增加润滑脂的注入量或咨询本公司；
When the strain wave reducer is used with the wave generator facing upward at low-speed (input rotational speed: 1000 r/min or less) in single direction, please contact us or our branch office as it may cause lubrication problems.
- 润滑脂的性能会随温度的升高而加速劣化，为保证润滑脂始终处于良好工作状态，谐波减速机高温端稳态热平衡温度应低于70°C，温升小于40°C；
The performance of grease will deteriorate with increasing of temperature. In order to ensure that the grease is in good working condition, the steady-state heat balance temperature at the high temperature end of strain wave reducer should be lower than 70°C, and the temperature rising should be less than 40°C.
- 减速机通过O型圈（静密封）和油封（动密封）对润滑脂进行密封，实质是内外压力的平衡。减速机内部油脂压力随温度的上升会有较大的增加，密封件能承受的最大压力越为0.03MPa；
As the grease is sealed by O-ring (static parts) and skeleton oil sealing (dynamic parts), it is essential to keep the balance of internal and external pressures. The oil pressure inside the reducer will change greatly by the temperature changes, and the maximum pressure is 0.03MPa.
- 根据不同油脂的选用以及减速机的实际使用情况，推荐润滑脂注入量为减速器内部空间的50%~70%，在保证不渗漏的情况下，油脂应尽可能多加，以保证长期使用有良好的润滑效果。
According to the types of different greases and reducers, it is recommended that the injection amount of grease should be 50~70% of the internal space of the reducer. Under the condition of no leakage, grease should be added as much as possible to ensure good lubrication effect in a long-term running.

谐波减速机性能参数

TECHNICAL DATA

CSF型 CSF Series

CSF系列谐波减速机，柔轮为杯形标准筒结构，输入轴通过十字联轴节与波发生器内孔配合，并通过平键连接，具有一定的自调心性。

The strain wave reducer of CSF series have a standard cup-shaped flexspline, the input shaft is matched with the inner hole of wave generator through Oldham's coupling which has a function of certain self-alignment.

参数表 Rated Parameters

型号 Model	速比 Reduction ratio	输入2000rpm时的 额定转矩N/m Rated torque @ 2000 r/min (N·m)	启停容许的 峰值扭矩N/m Permissible peak torque of starting/stopping (N·m)	平均负载转矩的 容许最大值N/m Permissible max. value of ave. load torque (N·m)	瞬间容许最 大转矩N/m Instantaneous permissible max. torque (N·m)	容许最高输入 转速rpm (脂润滑) Permissible max. input rotational speed (r/min)	容许平均输入 转速rpm Permissible ave. input rotational speed (r/min)	转动惯量 $\times 10^4 \text{kgm}^2$ Inertia moment ($\times 10^4 \text{kgm}^2$)	设计 寿命h Life in design (h)
14	50	5.4	18	6.9	35	8500	3500	0.033	10000
	80	7.8	23	11	47				
	100	7.8	28	11	54				
17	50	16	34	26	70	7300	3500	0.079	10000
	80	22	43	27	87				
	100	24	54	39	108				
20	50	25	56	34	98	6500	3500	0.193	10000
	80	34	74	47	127				
	100	40	82	49	147				
	120	40	87	49	147				
25	50	39	98	55	186	5600	3500	0.413	10000
	80	63	137	87	255				
	100	67	157	108	284				
	120	67	167	108	304				
32	50	76	216	108	382	4800	3500	1.690	10000
	80	118	304	167	568				
	100	137	333	216	647				
	120	137	353	216	686				

传动精度 Transmission accuracy

单位 unit: arc-min

速比 Reduction ratio	型号 Model	14	17	20	25	32
50		1.8	1.8	1.5	1.5	1.5
80以上 80 or more		1.5	1.5	1.2	1.2	1.2

回程误差 Lost motion

单位 unit: arc-min

速比 Reduction ratio	型号 Model	14	17	20	25	32
50		2.0	2.0	2.0	2.0	2.0
80以上 80 or more		1.0	1.0	1.0	1.0	1.0

最大齿隙量 Max. backlash quantity

单位 Unit: arc-sec

速比 Reduction ratio	型号 Model	14	17	20	25	32
50		60	60	36	36	36
80		40	40	32	32	32
100		35	35	35	30	30
120		-	-	-	28	28

● 扭转刚度 Torsional rigidity

符号 Symbol		型号 Model	14	17	20	25	32
T_1	N·m		2.00	3.90	7.00	14.0	29.0
T_2	N·m		6.90	12.0	25.0	48.0	108
速比50 Reduction ratio 50	$K_1 (\times 10^4 \text{ N·m/rad})$		0.34	0.81	1.30	2.50	5.40
	$K_2 (\times 10^4 \text{ N·m/rad})$		0.47	1.10	1.80	3.40	7.80
	$K_3 (\times 10^4 \text{ N·m/rad})$		0.57	1.30	2.30	4.40	9.80
	θ_1 (arc min)		2.00	1.70	1.80	1.90	1.90
	θ_2 (arc min)		5.60	4.20	5.30	5.40	5.40
速比80以上 Reduction ratio 80 or more	$K_1 (\times 10^4 \text{ N·m/rad})$		0.47	1.00	1.60	3.10	6.70
	$K_2 (\times 10^4 \text{ N·m/rad})$		0.61	1.40	2.50	5.00	11.0
	$K_3 (\times 10^4 \text{ N·m/rad})$		0.71	1.60	2.90	5.70	12.0
	θ_1 (arc min)		1.40	1.30	1.50	1.50	1.50
	θ_2 (arc min)		4.20	3.30	3.90	3.80	4.00

■ 外形图 Outline drawing

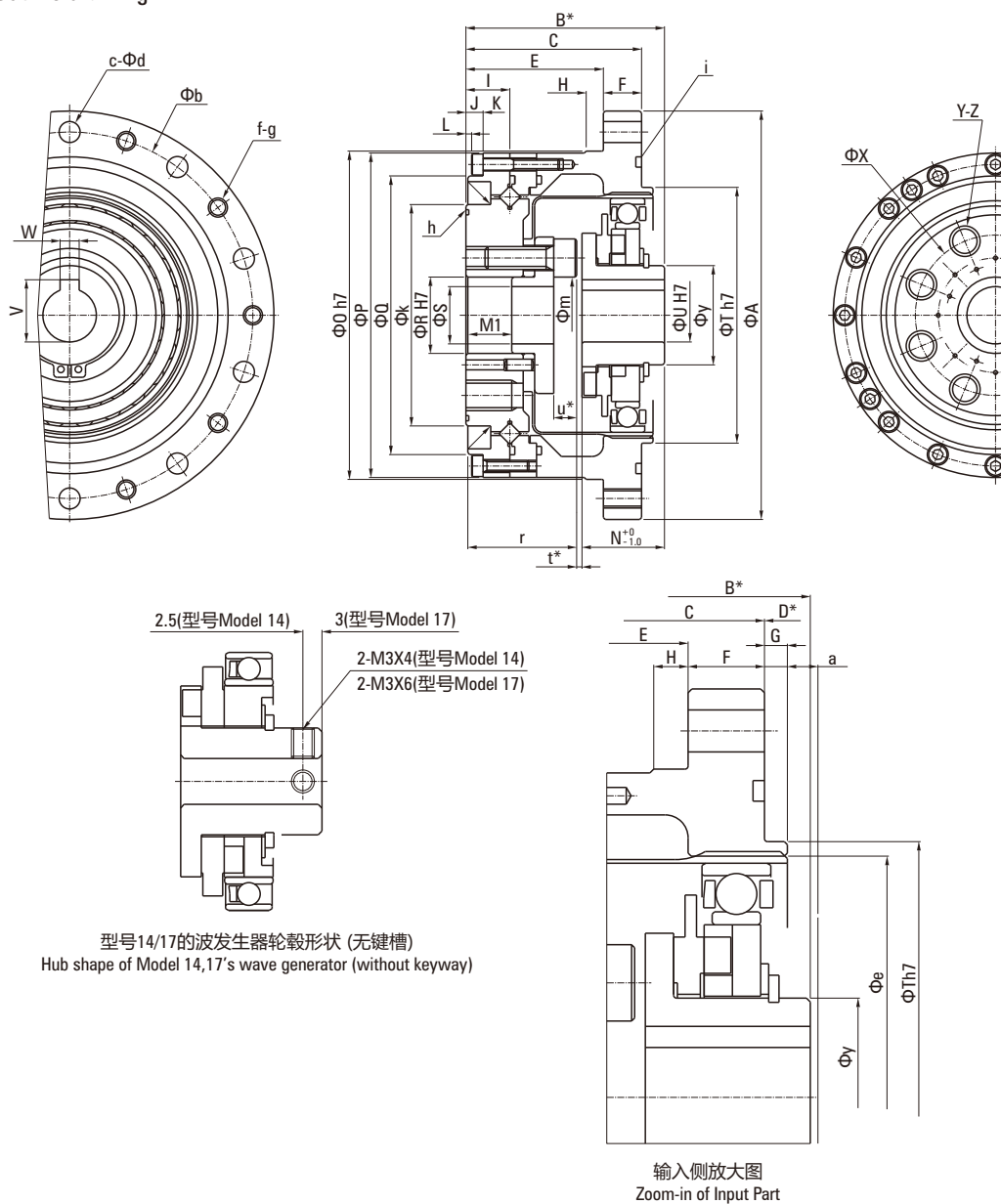

尺寸表 Specification Table

符号 Symbol	型号 Model	14	17	20	25	32
ΦA		73	79	93	107	138
B*		41 ⁺⁰ _{-0.9}	45 ⁺⁰ _{-0.9}	45.5 ⁺⁰ _{-1.0}	52 ⁺⁰ _{-1.0}	62 ⁺⁰ _{-1.1}
C		34	37	38	46	57
D*	CSG	7 ⁻⁰ _{-0.4}	8 ⁻⁰ _{-0.4}	7.5 ⁻⁰ _{-0.4}	6 ⁻⁰ _{-0.5}	5 ⁻⁰ _{-0.5}
	CSF	7 ⁻⁰ _{-0.8}	8 ⁻⁰ _{-0.9}	7.5 ⁻⁰ _{-1.0}	6 ⁻⁰ _{-1.0}	5 ⁻⁰ _{-1.1}
E		27	29	28	36	46
F		7	8	10	10	12
G		2	2	3	3	3
H		3.5	4	5	5	5
I		16.5	16.5	16.5	18.5	22.5
J		4.5	4.5	4	4.5	5.5
K		12	12	12.5	14	17
L		0.5	0.5	0.5	0.5	1.0
M1		9.4	9.5	9	12	15
N(⁺⁰ _{-0.1})	CSG	18.5	20.7	21.5	21.5	23.6
	CSF	17.6	19.5	20.1	20.2	22
Φ0 h7		56	63	72	86	113
ΦP		55	62	70	85	112
ΦQ		42.5	49.5	58	73	96
ΦR1 H7		11	10	14	20	26
ΦS		8	7	10	15	20
ΦT h7		38	48	56	67	90
ΦU h7		6	8	12	14	14
V		-	9.4 ^{+0.1} ₋₀	13.8 ^{+0.1} ₋₀	16.3 ^{+0.1} ₋₀	16.3 ^{+0.1} ₋₀
W Js9		-	3	4	5	5
ΦX		23	27	32	42	55
Y		6	6	8	8	8
Z		M4X8	M5X10	M6X9	M8X12	M10X15
a		1	1	1.5	1.5	1.5
Φb		65	71	82	96	125
c	CSG	8	8	8	10	12
	CSF	6	6	6	8	12
Φd		4.5	4.5	5.5	5.5	6.6
Φe		38	45	53	66	86
f	CSG	8	8	8	10	12
	CSF	6	6	6	8	12
g		M4	M4	M5	M5	M6
h		29X0.5	34.5X0.8	40.64X1.14	53.28X0.99	S71:70.5X2
i		48X2	53X2	66X2	78X2	102X2
Φk		31	38	45	58	78
Φm		10	10.5	15.5	20	27
r		21.4	23.5	23	29	37
t*	CSG	1.1	0.8	1	1.4	1.4
	CSF	2	2	2.4	2.8	3
u*	CSG	5.1	5.8	6	7.4	9.4
	CSF	6	7	7.4	8.8	11
Φy		14	18	21	26	26
重量 Wight (kg)		0.52	0.68	0.98	1.5	3.2

• 带*尺寸：B/D/t/u是减速器三大部件柔轮、刚轮、波发生器的轴向连接位置及容许公差。此尺寸重要，严格遵守。

Specification with * mark: The B, D, t, u indicate the mounting positions in the shaft direction and allowance of the three parts--wave generator, flexspline, circular spline. Strictly follow the requirement of these specifications as they affect the performance and intensity.

• 由于制造方法不同，公差会存在差异。

The dimension tolerances are existing according to different manufacturing methods.

• 产品出货时，波发生器独立包装。

The wave generator is packed separately when the product is delivered.

谐波减速机性能参数

TECHNICAL DATA

SHF-2UH型 SHF-2UH Series

SHF系列谐波减速机，柔轮为中空翻边形标准筒结构，波发生器凸轮为大口径中空轴形状，减速机内部设计有支撑轴承，为全密封结构，安装简单且刚性好，非常适于在需要从减速机内部穿线、穿轴的结构中使用。

The strain wave reducer of SHF-2UH Series have a hollow flanged flexspline, the cam of the wave generator is in the shape of a larger-diameter hollow shaft. The fully sealed reducer is designed with internal support bearings which is simple in installation and good in rigidity. It is very suitable for structures that need shaft threading from inside the reducer.

参数表 Rated Parameters

型号 Model	速比 Reduction ratio	输入2000rpm时的 额定转矩N/m Rated torque @ 2000 r/min (N-m)	启停容许的 峰值扭矩N/m Permissible peak torque of starting/stopping (N-m)	平均负载转矩的 容许最大值N/m Permissible max. value of ave. load torque (N-m)	瞬间容许最 大转矩N/m Instantaneous permissible max. torque (N-m)	容许最高输入 转速rpm (脂润滑) Permissible max. input rotational speed (r/min)	容许平均输入 转速rpm Permissible ave. input rotational speed (r/min)	转动惯量 $\times 10^{-4} \text{kgm}^2$ Inertia moment ($\times 10^{-4} \text{kgm}^2$)	设计 寿命h Life in design (h)
14	50	5.4	18	6.9	35	8500	3500	0.033	10000
	80	7.8	23	11	47				
	100	7.8	28	11	54				
17	50	16	34	26	70	7300	3500	0.079	10000
	80	22	43	27	87				
	100	24	54	39	108				
20	50	25	56	34	98	6500	3500	0.193	10000
	80	34	74	47	127				
	100	40	82	49	147				
	120	40	87	49	147				
25	50	39	98	55	186	5600	3500	0.413	10000
	80	63	137	87	255				
	100	67	157	108	284				
	120	67	167	108	304				
32	50	76	216	108	382	4800	3500	1.690	10000
	80	118	304	167	568				
	100	137	333	216	647				
	120	137	353	216	686				

传动精度 Transmission accuracy

单位 Unit: arc-min

速比 Reduction ratio	型号 Model	14	17	20	25	32
50		1.8	1.8	1.5	1.5	1.5
80以上 80 or more		1.5	1.5	1.2	1.2	1.2

回程误差 Lost motion

单位 Unit: arc-min

速比 Reduction ratio	型号 Model	14	17	20	25	32
50		2.0	2.0	2.0	2.0	2.0
80以上 80 or more		1.0	1.0	1.0	1.0	1.0

最大齿隙量 Max. backlash

单位 Unit: arc-sec

速比 Reduction ratio	型号 Model	14	17	20	25	32
50		60	60	36	36	36
80		40	40	32	32	32
100		35	35	35	30	30
120		-	-	-	28	28

● 扭转刚度 Torsional rigidity

符号 Symbol		型号 Model	14	17	20	25	32
T_1	N·m		2.00	3.90	7.00	14.0	29.0
T_2	N·m		6.90	12.0	25.0	48.0	108
速比50 Reduction ratio 50	$K_1 (\times 10^4 \text{ N·m/rad})$		0.34	0.81	1.30	2.50	5.40
	$K_2 (\times 10^4 \text{ N·m/rad})$		0.47	1.10	1.80	3.40	7.80
	$K_3 (\times 10^4 \text{ N·m/rad})$		0.57	1.30	2.30	4.40	9.80
	θ_1 (arc min)		2.00	1.70	1.80	1.90	1.90
	θ_2 (arc min)		5.60	4.20	5.30	5.40	5.40
速比80以上 Reduction ratio 80 or more	$K_1 (\times 10^4 \text{ N·m/rad})$		0.47	1.00	1.60	3.10	6.70
	$K_2 (\times 10^4 \text{ N·m/rad})$		0.61	1.40	2.50	5.00	11.0
	$K_3 (\times 10^4 \text{ N·m/rad})$		0.71	1.60	2.90	5.70	12.0
	θ_1 (arc min)		1.40	1.30	1.50	1.50	1.50
	θ_2 (arc min)		4.20	3.30	3.90	3.80	4.00

■ 外形图 Outline drawing

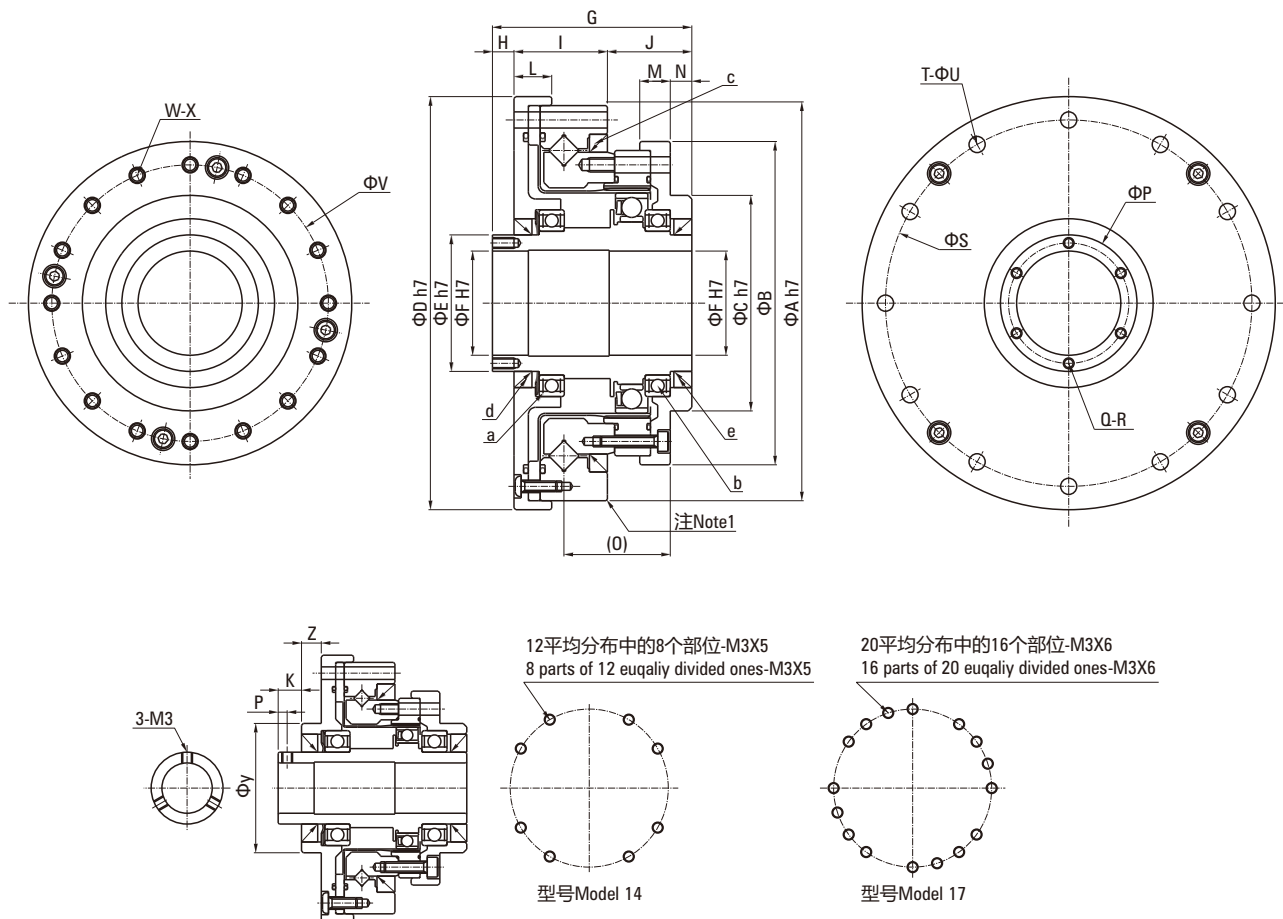

型号14/17的输入部形状
Shape of Input Part for Model 14 and 17

注1: 在安装凹圆上使用此位时, 需做避让加工。

Note 1: It is recommended to have a housing undercut on the install concave. Please check the confirmation drawing or contact us for dimension tolerances which are not shown in the drawing.

尺寸表 Dimensions Table

符号 Symbol	型号 Model	14	17	20	25	32
ΦA H7		70	80	90	110	142
ΦB		54	64	75	90	115
ΦC h7		36	45	50	60	85
ΦD h7		74	84	95	115	147
ΦE h7		20	25	30	38	45
ΦF H7		14	19	21	29	36
G		52.5	56.5	51.5	55.5	65.5
H		12	12	5	6	7
I		20.5	23	25	26	32
J		20	21.5	21.5	23.5	26.5
K		6.5	6.5	-	-	-
L		9	10	10.5	10.5	12
M		8	8.5	9	8.5	9.5
N		7.5	8.5	7	6	5
O		21.7	23.9	25.5	29.6	36.4
ΦP (P)		(2.5)	(2.5)	25.5	33.5	40.5
Q		3	3	6	6	6
R		M3	M3	M3X6	M3X6	M3X6
ΦS		64	74	84	102	132
T		8	12	12	12	12
ΦU		3.5	3.5	3.5	4.5	5.5
ΦV		44	54	62	77	100
W		12 E. A. 8	20 E. A. 16	16	16	16
X		M3X5	M3X6	M3X6	M4X7	M5X8
		Φ3.5X11.5	Φ3.5X12	Φ3.5X13.5	Φ4.5X15.5	Φ5.5X20.5
ΦY		36	45	-	-	-
Z		5.5	5.5	-	-	-
a		6804ZZ	6805ZZ	6806ZZ	6808ZZ	6809ZZ
b		6804ZZ	6805ZZ	6806ZZ	6808ZZ	6809ZZ
c		D49585	D59685	D69785	D84945	D1101226
d		S20304.5	S25356	S30405	S38475	S48607
e		S20304.5	S25356	S30405	S38475	S45555
重量 Mass (kg)		0.71	1.00	1.38	2.1	4.5

• 说明：由于制造方法不同，公差会存在差异。

The dimension tolerances are existing according to different manufacturing methods.

谐波减速机性能参数

TECHNICAL DATA

SHF-2UJ型 SHF-2UJ Series

该系列柔轮为中空翻边型标准筒结构，波发生器凸轮为实心轴结构，减速机内部设计有支撑轴承，为全密封结构，安装简单，适用于需要在输入端安装伞齿轮或同步带传动的场合使用。

The strain wave reducer of SHF-2UJ Series have a hollow flanged flexspline, and a wave generator whose cam is fixed on the input shaft. The fully sealed reducer is designed with internal supported bearings which is easy to install and suitable for structures where bevel gear or timing belt drive are necessary to be installed at the input end.

参数表 Rated Parameters

型号 Model	速比 Reduction ratio	输入2000rpm时的 额定转矩N/m Rated torque @ 2000 r/min (N·m)	启停容许的 峰值扭矩N/m Permissible peak torque of starting/stopping (N·m)	平均负载转矩的 容许最大值N/m Permissible max. value of ave. load torque (N·m)	瞬间容许最大 转矩N/m Instantaneous permissible max. torque (N·m)	容许最高输入 转速rpm (脂润滑) Permissible max. input rotational speed (r/min)	容许平均输入 转速rpm Permissible ave. input rotational speed (r/min)	转动惯量 $\times 10^{-4} \text{kgm}^2$ Inertia moment ($\times 10^{-4} \text{kgm}^2$)	设计 寿命h Life in design (h)
14	50	5.4	18	6.9	35	8500	3500	0.033	10000
	80	7.8	23	11	47				
	100	7.8	28	11	54				
17	50	16	34	26	70	7300	3500	0.079	10000
	80	22	43	27	87				
	100	24	54	39	108				
20	50	25	56	34	98	6500	3500	0.193	10000
	80	34	74	47	127				
	100	40	82	49	147				
	120	40	87	49	147				
25	50	39	98	55	186	5600	3500	0.413	10000
	80	63	137	87	255				
	100	67	157	108	284				
	120	67	167	108	304				
32	50	76	216	108	382	4800	3500	1.690	10000
	80	118	304	167	568				
	100	137	333	216	647				
	120	137	353	216	686				

传动精度 Transmission accuracy

单位 Unit: arc-min

速比 Reduction ratio	型号 Model	14	17	20	25	32
50		1.8	1.8	1.5	1.5	1.5
80以上 80 or more		1.5	1.5	1.2	1.2	1.2

回程误差 Lost motion

单位 Unit: arc-min

速比 Reduction ratio	型号 Model	14	17	20	25	32
50		2.0	2.0	2.0	2.0	2.0
80以上 80 or more		1.0	1.0	1.0	1.0	1.0

最大齿隙量 Max. backlash

单位 Unit: arc-sec

速比 Reduction ratio	型号 Model	14	17	20	25	32
50		60	60	36	36	36
80		40	40	32	32	32
100		35	35	35	30	30
120		-	-	-	28	28

● 扭转刚度 Torsional rigidity

符号 Symbol		型号 Model	14	17	20	25	32
T_1		N·m	2.00	3.90	7.00	14.0	29.0
T_2		N·m	6.90	12.0	25.0	48.0	108
速比50 Reduction ratio 50	K_1 ($\times 10^4$ N·m/rad)		0.34	0.81	1.30	2.50	5.40
	K_2 ($\times 10^4$ N·m/rad)		0.47	1.10	1.80	3.40	7.80
	K_3 ($\times 10^4$ N·m/rad)		0.57	1.30	2.30	4.40	9.80
	θ_1 (arc min)		2.00	1.70	1.80	1.90	1.90
	θ_2 (arc min)		5.60	4.20	5.30	5.40	5.40
速比80以上 Reduction ratio 80 or more	K_1 ($\times 10^4$ N·m/rad)		0.47	1.00	1.60	3.10	6.70
	K_2 ($\times 10^4$ N·m/rad)		0.61	1.40	2.50	5.00	11.0
	K_3 ($\times 10^4$ N·m/rad)		0.71	1.60	2.90	5.70	12.0
	θ_1 (arc min)		1.40	1.30	1.50	1.50	1.50
	θ_2 (arc min)		4.20	3.30	3.90	3.80	4.00

■ 外形图 Outline drawing

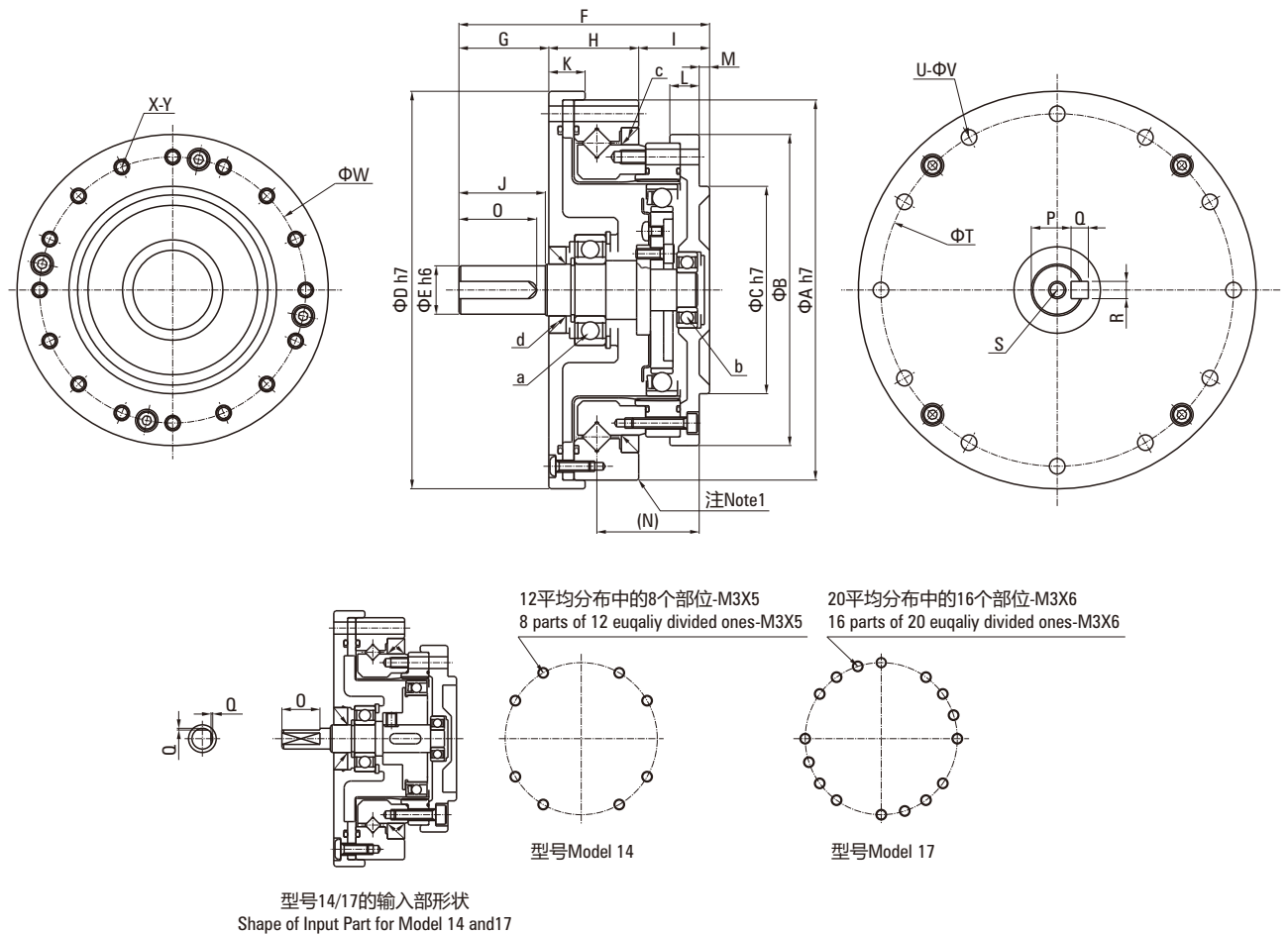

注1: 在安装凹圆上使用此位时, 需做避让加工。
Note 1: It is recommended to have a housing undercut on the install concave.

尺寸表 Dimensions Table

符号 Symbol	型号 Model	14	17	20	25	32
ΦA H7		70	80	90	110	142
ΦB		54	64	75	90	115
ΦC h7		36	45	50	60	85
ΦD h7		74	84	95	115	147
ΦE h7		6	8	10	14	14
F		50.5	56	63.5	72.5	84.5
G		15	17	21	26	26
H		20.5	23	25	26	32
I		15	16	17.5	20.5	26.5
J		14	16	20	25	25
K		9	10	10.5	10.5	12
L		8	8.5	9	8.5	9.5
M		2.5	3	3	3	5
N		21.7	23.9	25.5	29.6	36.4
O		11	12	16.5	22.5	22.5
P		-	-	8.2 ⁺⁰ _{-0.1}	11 ⁺⁰ _{-0.1}	11 ⁺⁰ _{-0.1}
Q		0.5	0.5	3 ⁰ _{0.025}	5 ⁰ _{0.03}	5 ⁰ _{0.03}
R		-	-	3 ⁰ _{0.025}	5 ⁰ _{0.03}	5 ⁰ _{0.03}
S		-	-	M3X6	M5X10	M5X10
ΦT		64	74	84	102	132
U		8	12	12	12	12
ΦV		3.5	3.5	3.5	4.5	5.5
ΦW		44	54	62	77	100
X		12 E. A. 8	20 E. A. 16	16	16	16
Y		M3X5	M3X6	M3X6	M4X7	M5X8
		Φ3.5X11.5	Φ3.5X12	Φ3.5X13.5	Φ4.5X15.5	Φ5.5X20.5
a		698ZZ	6900ZZ	6902ZZ	6903ZZ	6904ZZ
b		695ZZ	697ZZ	698ZZ	6900ZZ	6902ZZ
c		D49585	D59685	D69785	D84945	D1101226
d		G8184	D10205	D15255	D15255	D20355
重量 Mass (kg)		0.66	0.94	1.38	2.1	4.4

• 说明：由于制造方法不同，公差会存在差异。。

The dimension tolerances are existing according to different manufacturing methods.

外形图: SHF-2SO OUTLINE DRAWING: SHF-2SO

外形图 Outline drawing

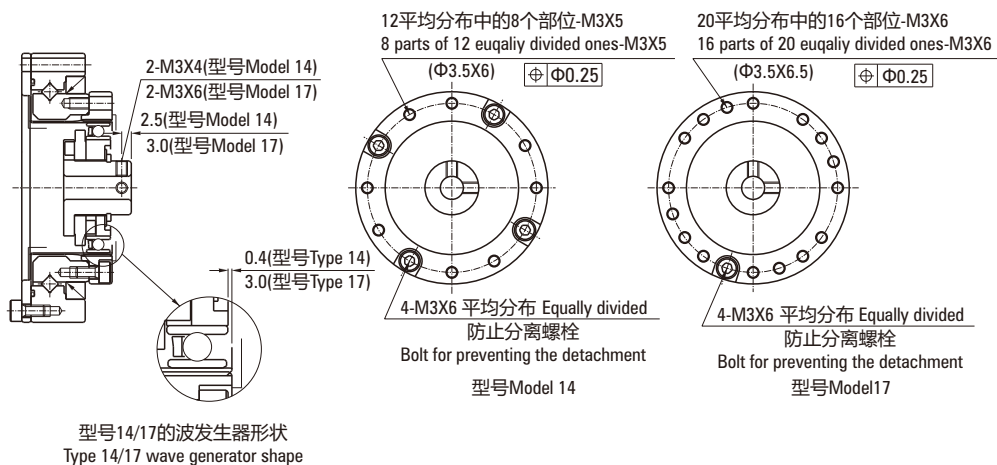
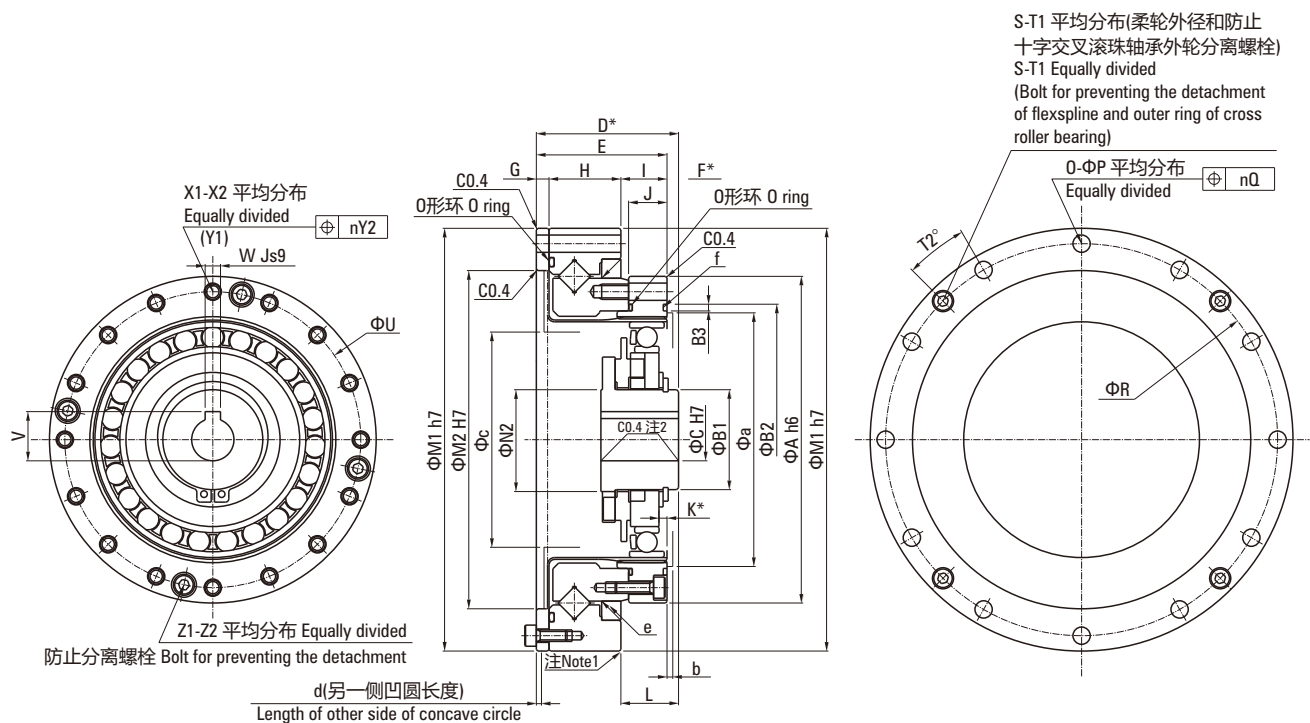

注1: 在安装凹圆上使用此位时, 需做避让加工。

注2: 14型号C0.5.

Notes 1: It is recommended to have a housing undercut on the install concave.

Notes 2: C0.5 for model 14 .

尺寸表 Dimensions Table

符号 Symbol	型号 Model	14	17	20	25	32
	ΦA h6	50	60	70	85	110
	ΦB1	14	18	21	26	26
ΦC H7	标准 Standard	6	8	9	11	14
	最大 Max	8	10	13	15	15
D*	SHF	28.5 ⁺⁰ _{-0.8}	32.5 ⁺⁰ _{-0.9}	33.5 ⁺⁰ _{-1.0}	37 ⁺⁰ _{-1.1}	44 ⁺⁰ _{-1.1}
	SHG	28.5 ⁺⁰ _{-0.8}	32.5 ⁺⁰ _{-0.9}	33.5 ⁺⁰ _{-1.0}	37 ⁺⁰ _{-1.1}	44 ⁺⁰ _{-1.1}
	E	23.5	26.5	29	34	42
	F*	5	6	4.5	3	2
	G	2.4	3	3	3.3	3.6
	H	14.1	16	17.5	18.7	23.4
	I	7	7.5	8.5	12	15
	J	6	6.5	7.5	10	14
K*	SHF	0.4	0.3	0.1	2.1	2.5
	SHG	1.4	1.6	1.5	3.5	4.2
L	SHF	17.6 ⁺⁰ _{-0.1}	19.5 ⁺⁰ _{-0.1}	20.1 ⁺⁰ _{-0.1}	20.2 ⁺⁰ _{-0.1}	22 ⁺⁰ _{-0.1}
	SHG	18.5 ⁺⁰ _{-0.1}	20.7 ⁺⁰ _{-0.1}	21.5 ⁺⁰ _{-0.1}	21.6 ⁺⁰ _{-0.1}	23.6 ⁺⁰ _{-0.1}
	ΦM1	70	80	90	110	142
	ΦM2	48	60	70	88	114
	O	8	12	12	12	12
	ΦP	3.5	3.5	3.5	4.5	5.5
	ΦQ	0.25	0.25	0.25	0.25	0.25
	ΦR	64	74	84	102	132
	S	2	4	4	4	4
	T1	M3X6	M3X6	M3X8	M3X8	M4X8
	T2 (角度)	22.5°	15°	15°	15°	15°
	ΦU	44	54	62	77	100
	V	-	-	10.4	12.8	16.3
	W Js9	-	-	3	4	5
	X1	12 E. A. 8	20 E. A. 16	16	16	16
	X2	M3X5	M3X6	M3X6	M4X7	M5X8
	Y1	Φ3.5X6	Φ3.5X6.5	Φ3.5X7.5	Φ4.5X10	Φ5.5X14
	Y2	0.25	0.25	0.25	0.25	0.25
	Z1	4	4	4	4	4
	Z2	M3X6	M3X6	M3X8	M3X10	M4X16
壳体内壁 Housing inner wall	Φa	38	45	53	66	86
	b	1	1	1.5	1.5	1.5
	Φc	31	38	45	56	73
	d	1.7	2.1	2	2	2
	e	D49585	D59685	D69785	D84945	D1101226
	重量 Weight (kg)	0.41	0.57	0.81	1.31	2.94

• 带*尺寸：D/F/K 是减速器三大部件柔轮、刚轮、波发生器的轴向连接位置及容许公差。此尺寸重要，严格遵守。

Specification with * mark: The D/F/K indicate the mounting positions in the shaft direction and allowance of the three parts--wave generator, flexspline, circular spline. Strictly follow the requirement of these specifications as they affect the performance and intensity.

• 刚轮上没有安装O形圈的环形槽（符号f），设计、安装时须严格采取油封措施。

Please note that in the circular spline there does not incorporate an O-ring groove (symbol f). Please provide alternate sealing arrangements during the designing and installing.

• 由于柔轮会发生弹性变形，为防止其与壳体接触，请使用大于Φa/b/c，小于D的内壁尺寸。

Due to the deformation of the Flexspline during operation, it is necessary to provide a minimum housing clearance, dimensions Φa, b, c.

• 产品出货时，波发生器独立包装。

The wave generator is packed separately when the product is delivered.

• 波发生器C尺寸，柔轮O/P尺寸，刚轮X₁/X₂尺寸可定制加工。

The following dimensions can be modified to accommodate customer-specific requirements.

Wave Generator: C

Flexspline: O and P

Circular Spline: X₁ and X₂.

外形图: SHF-2SH OUTLINE DRAWING: SHF-2SH

外形图 Outline drawing

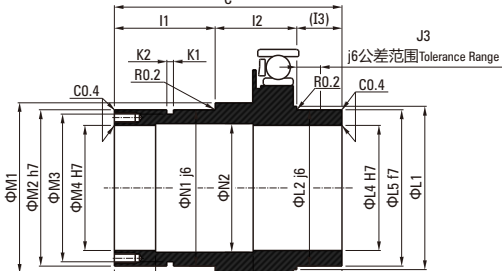
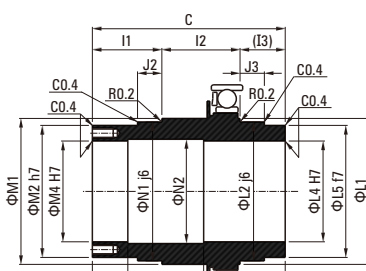
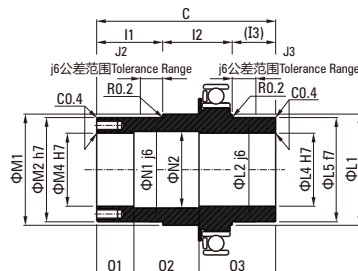
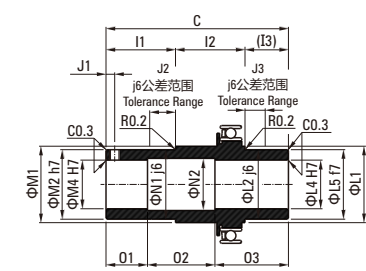
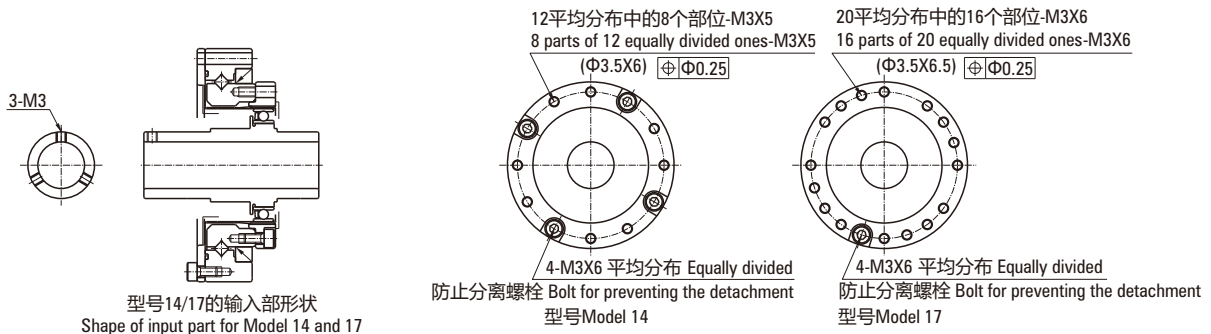
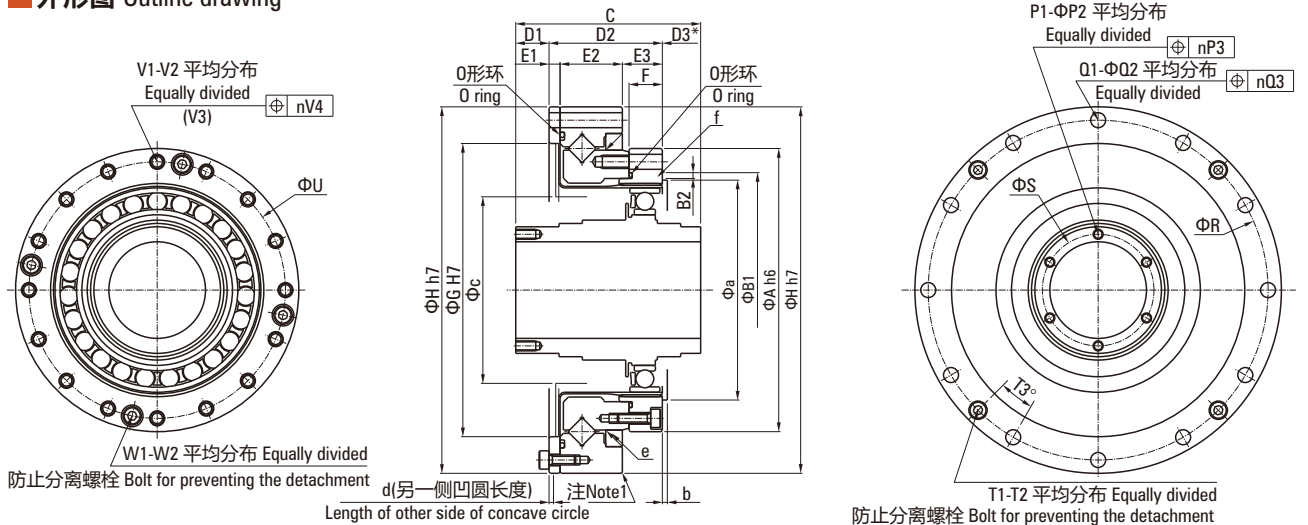

注1: 在安装凹圆上使用此位时, 需做避让加工。

注2: 波发生器形状会根据各型号不同而有所差异, 务必依交货时的外形图确认。尺寸的详细情况, 请使用交货时的外形图进行确认。

Note 1: It is recommended to have a housing undercut on the install concave.

Note 2: Refer to the confirmation drawing for detailed dimensions. Especially be certain to check the delivered specifications since the configuration of the wave generator varies depends on the size.

尺寸表 Dimension Table

符号 Symbol		型号 Model	14	17	20	25	32
ΦA h6			50	60	70	85	110
ΦB1			-	-	-	-	-
C			52.5 ⁺⁰ _{-0.1}	56.5 ⁺⁰ _{-0.1}	51.5 ⁺⁰ _{-0.1}	55.5 ⁺⁰ _{-0.1}	65.5 ⁺⁰ _{-0.1}
D1*	SHF		16 ^{+0.8} ₊₀	16 ^{+0.9} ₊₀	9.5 ^{+1.0} ₊₀	10 ^{+1.1} ₊₀	12 ^{+1.1} ₊₀
	SHG		16 ^{+0.4} ₊₀	16 ^{+0.4} ₊₀	9.5 ^{+0.4} ₊₀	10 ^{+0.5} ₊₀	12 ^{+0.6} ₊₀
D2			23.5	26.5	29	34	42
D3*			13	14	13	11.5	11.5
E1			2.4	3	3	3.3	3.6
E2			14.1	16	17.5	18.7	23.4
E3			7	7.5	8.5	12	15
F			6	6.5	7.5	10	14
ΦG H6			48	60	70	88	114
ΦH h6			70	80	90	110	142
波发生器尺寸 Wave generator dimensions	I1		20±0.1	21.5±0.1	19±0.1	20±0.1	29±0.1
	I2		20±0.1	21.5±0.1	20±0.1	22.5±0.1	23.5±0.1
	(I3)		12.5	13.5	12.5	13	13
	J1		2.5	2.5	-	-	-
	J2		7	7	7	6.5	-
	J3		7	7	7	6.5	-
	J4		-	-	-	-	-
	K1		-	-	-	-	-
	K2		-	-	-	-	-
	ΦL1		22	27	32	42	47
	ΦL2 j6		20	25	30	40	45
	ΦL3 h9		-	-	-	38	-
	ΦL4 H7		14	19	21	29	36
	ΦL5 f7		20	25	30	-	45
	ΦM1		22	27	32	42	49
	ΦM2 h7		20	25	30	38	45
	ΦM3		-	-	-	-	42.5
	ΦM4 H7		14	19	21	29	36
	ΦN1 j6		20	25	30	40	45
	ΦN2		14.5	19.5	21.5	29.5	36.5
O1		10	10	10	10	10	
O2		22.5	24.5	(19.5)	22.5	(30.5)	
O3		20	22	22	23	25	
P1		3	3	6	6	6	
P2		M3	M3	M3X6	M3X6	M3X6	
ΦP3		-	-	0.25	0.25	0.25	
Q1		8	12	12	12	12	
ΦQ2		3.5	3.5	3.5	4.5	5.5	
ΦQ3		0.25	0.25	0.25	0.25	0.25	
ΦR		64	74	84	102	132	
ΦS		-	-	25.5	33.5	40.5	
T1		2	4	4	4	4	
T2		M3X6	M3X6	M3X8	M3X8	M4X8	
T3 (角度 angle)		22.5°	15°	15°	15°	15°	
ΦU		44	54	62	77	100	
V1		12平均分布中8 8 parts of 12 equally divided ones	20平均分布中16 16 parts of 20 equally divided ones	16	16	16	
V2		M3X5	M3X6	M3X6	M4X7	M5X8	
V3		Φ3.5X6	Φ3.5X6.5	Φ3.5X7.5	Φ4.5X10	Φ5.5X14	
V4		0.25	0.25	0.25	0.25	0.25	
W1		4	4	4	4	4	
W2		M3X6	M3X6	M3X8	M3X10	M4X16	
壳体内壁 Minimum housing clearance	Φa		38	45	53	66	86
	b		1	1	1.5	1.5	1.5
	Φc		31	38	45	56	73
d		1.7	2.1	2	2	2	
e		D49585	D59685	D69785	D84945	D1101226	
重量 Mass (kg)		0.45	0.63	0.89	1.44	3.1	

• 带*尺寸：D/F/K 是减速器三大部件柔轮、刚轮、波发生器的轴向连接位置及容许公差。此尺寸重要，严格遵守。

Specification with * mark: The D/F/K indicate the mounting positions in the shaft direction and allowance of the three parts--wave generator, flexspline, circular spline. Strictly follow the requirement of these specifications as they affect the performance and intensity.

• 刚轮上没有安装O形圈的环形槽（符号f），设计、安装时须严格采取油封措施。

Please note that in the circular spline there does not incorporate an O-ring groove (Symbol f). Please provide alternate sealing arrangements during the designing and installing.

• 由于柔轮会发生弹性变形，为防止其与壳体接触，请使用大于Φa/b/c，小于D的内壁尺寸。

Due to the deformation of the Flexspline during operation, it is necessary to provide a minimum housing clearance, dimensions Φa, b, c.

• 产品出货时，波发生器独立包装。

The wave generator is packed separately when the product is delivered.

• 波发生器C尺寸，柔轮O/P尺寸，刚轮X₁/X₂尺寸可定制加工。

The following dimensions can be modified to accommodate customer-specific requirements.

Wave Generator: C

Flexspline: O and P

Circular Spline: X₁ and X₂.

安全使用的注意事项 FOR SAFE USE

■ 减速机使用注意事项 Operational Precaution

● 请在规定环境下使用

Please use only in a specified environment

环境温度：0~40°C Ambient temperature: 0 to 40°C

不溅到水、油等 No splashing of water or oil

无腐蚀性、爆炸性气体 Do not expose to corrosive or explosive gas

无金属粉等灰尘 No dust such as metal powder

● 请勿变更部件配套

Do not change a set of parts

本产品的各部件是配套加工而成，混同其他套件使用时，无法保证其能够发挥特定性能。

The product is manufactured with sets of parts. The specified performance may not be ensured if different parts of other gearbox are used.

● 请勿拆解组合型产品 Do not break down unified product

严禁对组合型产品实施拆解、重新组装。否则将无法恢复其原有性能
Do not break down and re-assemble unified product. Original performance may not be ensured.

● 使用时请勿超出容许转矩

Apply torque within the allowable range

施加转矩请不要超出瞬间容许最大转矩，否则可能会出现拧紧部螺栓松动、产生晃动、破坏等，导致产品故障。

Do not apply torque which exceeds the instantaneous allowable max. torque. It can cause troubles such as loose tightening bolts, vibration and breakdown of the product.

如果输出轴直接连接关节臂等，有可能因关节臂碰撞而导致破损、输出轴不能控制。

It may cause damage a robotic arm or lead to uncontrolled of the output shaft if the output shaft is directly conncted with a robotic arm ect.

● 请使用规定的方法、精度要求进行安装

Install the equipment in a specified manner considering the requirement of accuracy

组装方法、顺序，请按照产品目录正确实施；

Assemble according to the the specified order of the catalog.

拧紧方法（使用螺栓等），请遵守本公司建议；

Contact us for recommended tightening methods (such as, bolts).

请正确设计、组装各部件，确保能够达到产品目录中的推荐安装精度；

Keep the recommended installation precision on our catalog during the design and installation of parts.

如未正确组装或精度未达到要求，可能会导致谐波减速机的振动、寿命降低、精度下降、损坏等故障；

Incorrectly assemble or without of the range of required accuracy, could cause troubles such as vibration, degrade of life, deterioration of precision and breakdown etc.

请小心取用产品及部件；

Be careful in handing products and parts.

请勿使用锤子等用力敲打各部件及组合单元。此外，请确保不会因坠落等原因导致裂纹、瘪痕等。否则会导致产品破损；

Do not apply strong impact on parts or units with a hammer, etc. Do not scratch, bruise, or drop them which will lead to the damage of gearbox.

在破损状态下使用时，无法保证其性能，还可能导致损坏等故障。

The specified performance could not be ensured if the reducer is used in a damaged condition. It can also cause troubles such as breakdown.

● 请勿拆解组合型产品

Do Not Disassemble The Combined Product

本产品的各部件是配套加工而成，混同其他套件使用时，无法保证其能够发挥特定性能。

It is strictly forbidden to disassemble and reassemble the combined products.

Otherwise, the original performance will not be restored.

安全使用注意事项 FOR SAFE USE

■ 润滑剂使用的注意事项 Precautions of lubricant

● 安装注意事项 Precautions of lubricant handing

溅入眼中可能会引起炎症，操作时应佩戴防护眼镜等，避免溅入眼睛。
Wear a protective glasses to prevent the lubricant from getting in your eye when you handle it, because it could cause an inflammation of eyes.

接触到皮肤可能会引起炎症，操作时，请佩戴防护手套，避免接触到皮肤。

Wear protective gloves to prevent the lubricant from contacting your skin when you handle it, because it could cause an inflammation of your skins.

请勿吞食。Do not eat it.

打开容器时，请注意不要划伤手指，请戴好防护手套。

Wear protective gloves when opening the container, you might have your hand cut by it.

请放在儿童够不到的地方。Keep lubricant off children.

● 废油、废容器的处理 Treatment of waste oil and containers

法令规定了使用者有义务实施的处理方法，请按照相关法律法规进行正确处理；不清楚时，请先咨询授权代理商，然后再做处理。

Treatment methods are obliged by laws. Treat wastes should be handled according to the laws. If you are unsure how to handle with them, please consult with the dealer before handling with them.

请勿对空的容器施加压力，施加压力可能会导致其破裂。

Do not apply pressure on an empty container. The container may blow up.

请勿对容器进行焊接、加热、开孔或裁切，否则可能会发生爆炸，里面的残留物会起火燃烧。

Do not weld, heat, drill or cut the container. The remainder may ignite with an explosion.

● 应急处理 First-aid

万一溅入眼中，请立即使用清水冲洗15分钟，并接受医生的治疗。

If lubricant get in your eye, you should wash your eye with clean water for 15 minutes and accept medical treatment.

万一接触到皮肤，请使用水及肥皂清洗干净。

If lubricant comes in contact with your skin, you should thoroughly wash it with water and soap.

万一发生吞食，请不要用力让其呕吐，应立即接受医生治疗。

If you swallowed it, you should immediately accept medical treatment without throwing it up by constraint.

● 保管方法 Storage

使用后，请将其密封好，防止灰尘、水分等混入。请在背阴处保存，避免阳光直射。

Tightly plug the container after using in order to prevent intrusion of dusts and water. Avoid direct sunlight and store lubricant in a dark place.

对于长期库存的产品，建议确认性能及防锈是否做好。

When a product has been stored for a long period of time, please check its performance and keep it from rust.

表面处理的详情请参阅交货图纸。

Please refer to the delivered drawings for details of surface treatment.

● 关于报废 About discarding

报废时，请按工业废弃物进行处理。

Please discarding as industrial waste when discarding.

主要应用领域 THE MAIN MARKETS OF APPLICATIONS

■ 医疗器械 Medical Equipment

■ 光伏设备 Photovoltaic Device

■ 工业机器人 Industrial Robot

■ 通信设备 Communication Equipment

■ 能源相关 Energy related device

关于保修 WARRANTY PERIOD AND TERMS

■ 保修期 Warranty Period

以产品目录记载的正常组装状态及润滑状态下使用为前提，保修期为交货后的一年时间或该产品运行时间达到2000h两者中最先到达的时间。

Under the conditions that the products are handled, used and maintained properly followed each item of the technical manuals and this catalog, all the products are warranted against defects in workmanship and materials for the shorter period of either one year after its delivery or 2,000 hours of operation time.

■ 保修范围 Warranty Terms

在上述保修期内，因本公司制造缺陷导致故障时，由本公司负责对产品进行维修或更换。

但以下情况不在保修范围内：

All the products are warranted against defects in workmanship and materials for the warranted period. This limited warranted does not apply to any product that has been subject to:

- 因客户不当操作或违规使用导致故障的；
User's misapplication, improper installation, inadequate maintenance, or misuse.
- 非本公司实施的改造或修理导致故障的；
Disassembling, modification or repair by others than ZD.
- 非本产品原因导致故障的；
Imperfection caused by the other products.
- 天灾等非本公司责任导致故障的。

Natural disasters or others that do not belong to the responsibilities of ZD.

这里所说的保修仅限于对本产品的保修，对于因本产品故障引发的其他损失、与在设备上拆装相关的工时、费用等，不在本公司负责范围内。

Our liability shall be limited exclusively to repairing or replacing the product only found by ZD to be defective. ZD shall not be liable for consequential damages of other equipment caused by the defective products, and shall not be liable for the incidental and consequential expenses and the labor costs for detaching and installing to the driven equipment.

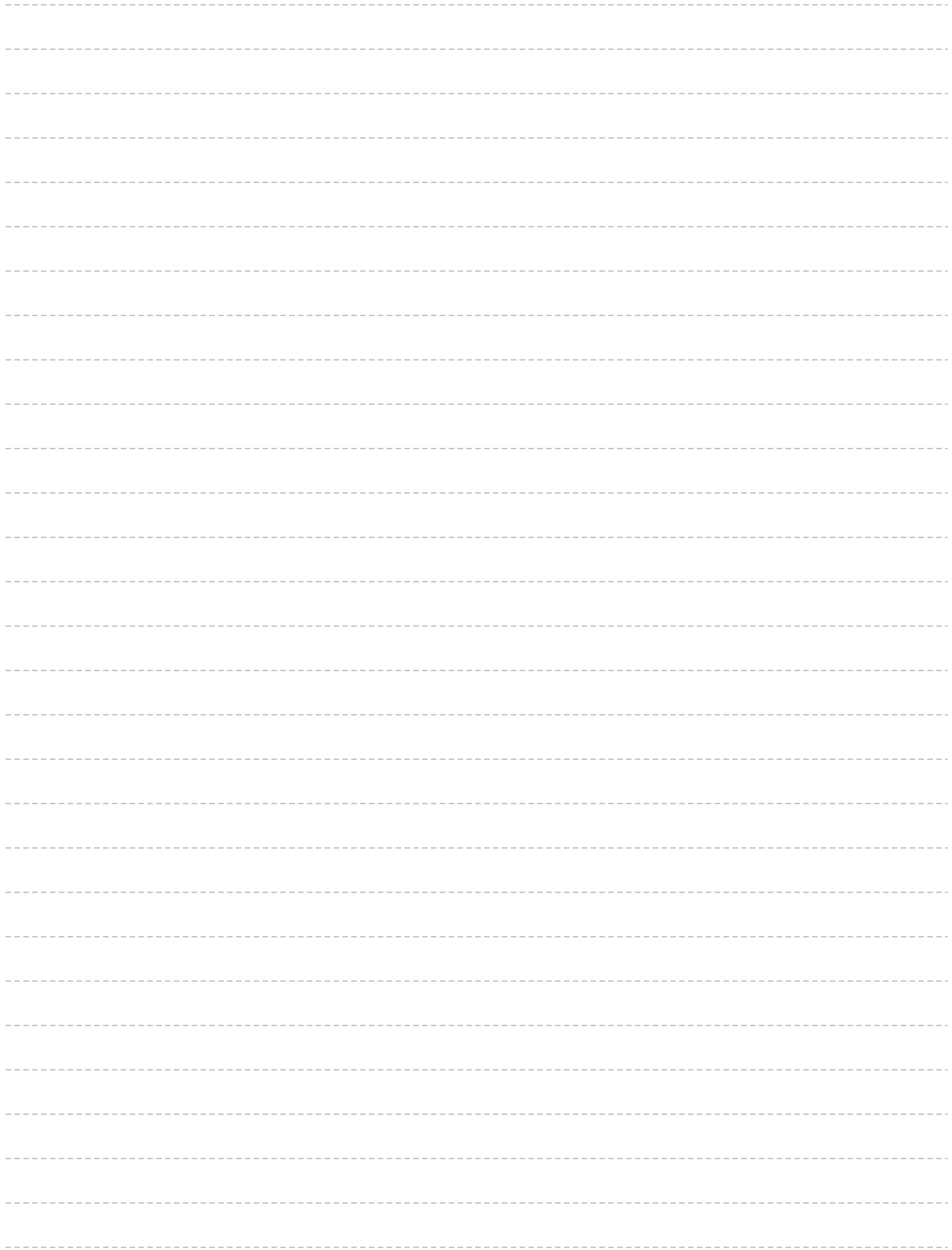

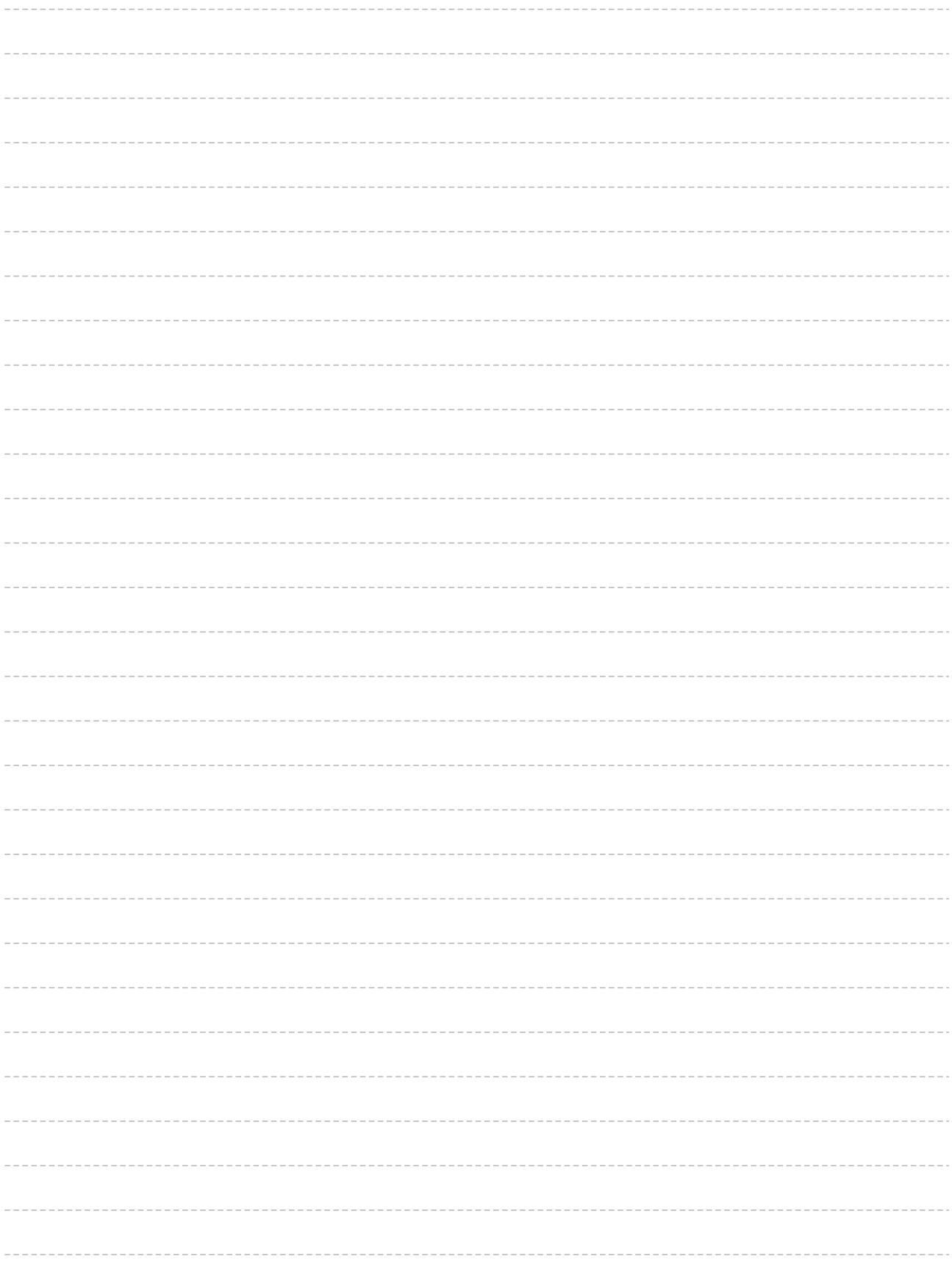

CATALOGUE



PLANETARY GEAR BOX
ZB/ZE系列
高精度行星减速机

ZD 中大刀德



PLANETARY GEAR BOX
ZDR/ZDGF(S)系列
高精度行星减速机

ZD 中大刀德



PLANETARY GEAR BOX
ZDE/ZDF/ZDWE/ZDWF/ZDS系列
高精度行星减速机

ZD 中大刀德

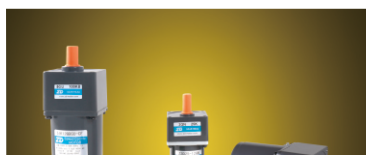

AC & DC GEAR MOTOR
微型交、直流减速电动机

ZD 中大刀德



AC & DC RIGHT ANGLE GEAR MOTOR
交、直流直角轴减速电动机

ZD 中大刀德



SMALL AC GEAR MOTOR
小型交流平行轴齿轮减速电机

ZD 中大刀德

PRECISION STRAIN WAVE GEAR REDUCER

宁波中大力德智能传动股份有限公司
NINGBO ZHONGDA LEADER INTELLIGENT TRANSMISSION CO.,LTD.

地址：浙江省慈溪高新技术产业开发区新兴一路185号

Add : NO.185 1st Xinxing Road,New Industrial Zone, Cixi City, Zhejiang, China.

国内贸易服务：

电话：0574-63537377

传真：0574-63534879

E-mail: china@zd-motor.com

国际贸易服务：

International trade department:

Tel: 86-574-63530538 Fax: 86-574-63534879

E-mail: manager@zd-motor.com

E-mail: trade@zd-motor.com

更多详情，敬请浏览：
www.zd-motor.com