

DRUM MOTOR

电动滚筒电机

滚筒发展史 DRUM MOTOR DEVELOPMENT HISTORY

■ 使用 Use

与传统驱动系统相比，电动滚筒的安装要快速的多，筒易的多、零件少，意味着输送机设计和零件采购的成本越低。

Compared with the traditional drive system, the installation of drum motor is much easier, simpler, which means lower cost of designing and purchasing.

■ 耐用 Durable

即使113、138、165系列的电动滚筒在充满水、灰尘、化学品、油脂、油的不利环境条件下。乃至高压冲洗期间都可以保持正常的运行。

Even under severe conditions, full of water, dust, chemicals, oil, grease, even during high-pressure water washing, 113, 138, 165 series drum motors can normally operate.

■ 设计卫生 Sanitary Design

由于采用的是光面不锈钢材料，而且是紧密密封和全封闭式设计，因此电动滚筒更易于清洁，从而降低了食品加工过程中受污染的风险。

Due to the smooth stainless steel material, and tightly sealed and fully enclosed design, drum motor is easier to clean, thus reducing the risk of contamination in food processing.

■ 节约空间 Save Space

由于电机、齿轮变速箱和轴承都安装在滚筒内部中，电动滚筒所占的空间要少很多。

Because the motor, gearbox and bearings are installed inside of the drum, drum motor occupies less space.

■ 安全 Security

作为没有突出零件且外部轴固定的整装部件，电动滚筒或许是可用于一流物料搬运设备的最安全的驱动装置。

As a complete unit with no protruding parts and fixed by external axial, drum motor is the safest drive system used for first-class transporting equipments.

● 第一代 First Generation

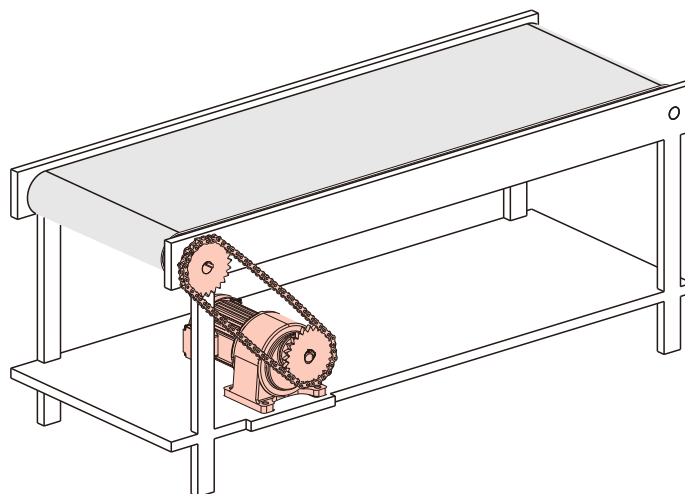

● 第二代 Second Generation

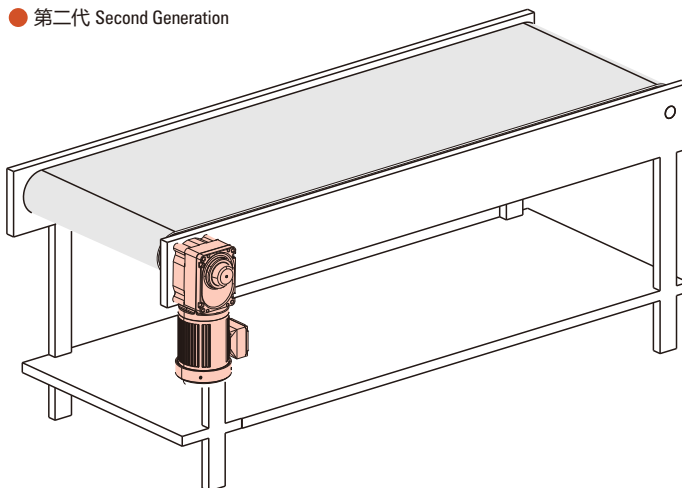

● 第三代 Third Generation

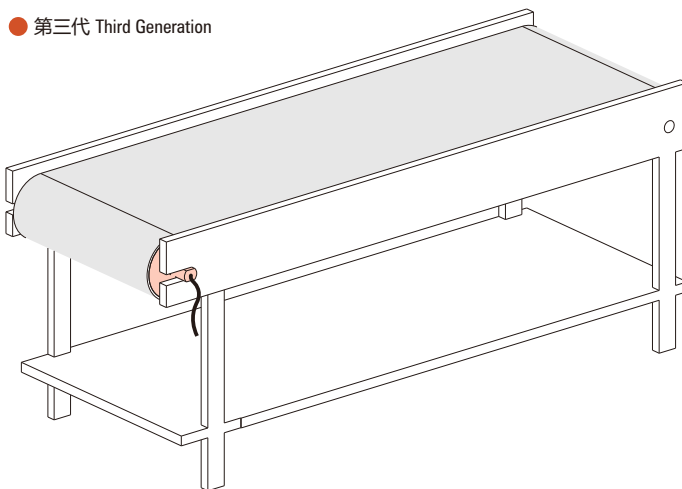

交流电动滚筒电机 AC DRUM MOTOR

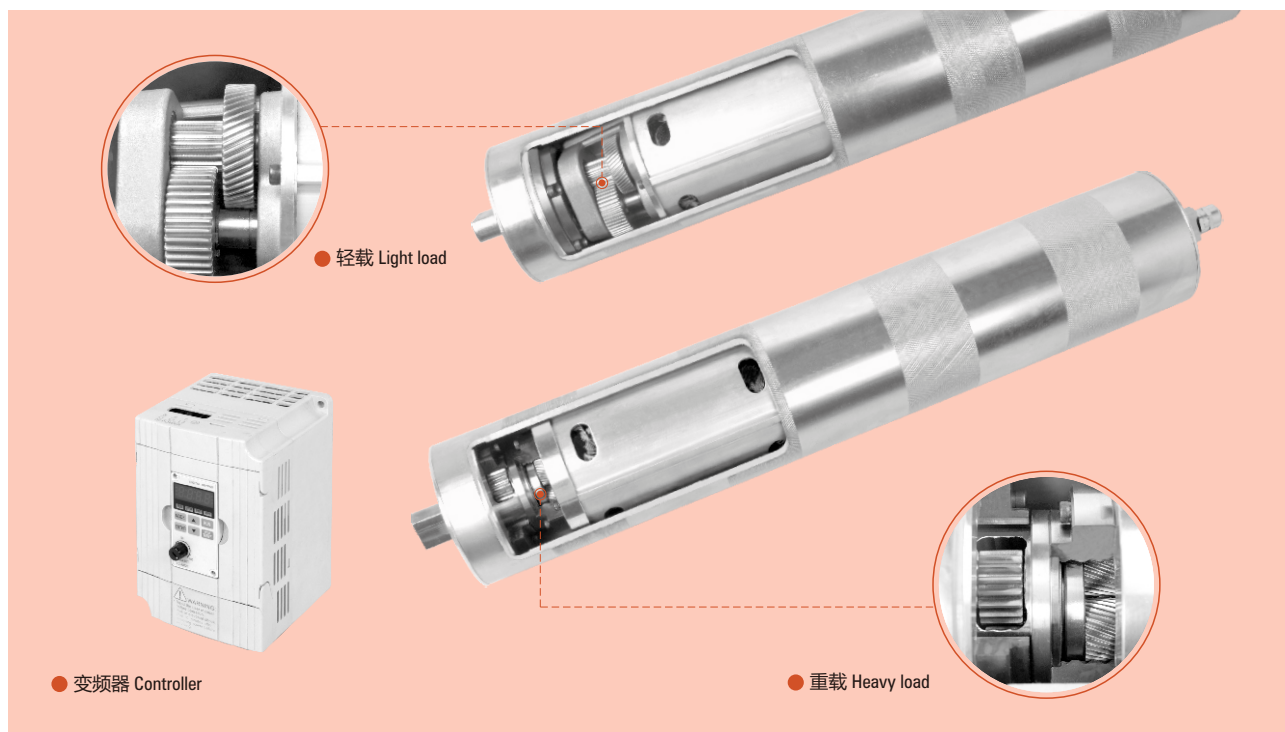

品名的阅读方法 MODEL NO. CODING

电动机 Motor

ZD DM T 60 - A - 25 - 400 - 40 - 1 - 110 - G1 - M
 ① ② ③ ④ ⑤ ⑥ ⑦ ⑧ ⑨ ⑩ ⑪ ⑫

①	公司名称 Company	中大电机 ZD Motor			
②	型号尺寸 Model & Dimension				
	电机种类 Motor type	DM: 轻载型滚筒电机 Light load type drum motor	DMX: 重载型滚筒电机 Heavy load type drum motor		
③	滚筒材质 Drum material	T: 碳钢管(可省略) T: Carbon steel tube (Omissible) S: 304不锈钢管 S: 304 stainless steel tube			
④	滚筒直径 Drum diameter	(例) 60: 滚筒外径60mm (Example) 60: Drum diameter 60mm			
⑤	滚筒形状 Drum shape	A: 圆柱形筒体 A: Cylindrical tube	B: 冠状筒体 B: Crowned tube	C: 圆柱筒体+键 C: Cylindrical shell + key	
⑥	线速度 Linear speed	(例) 25: 滚筒转动线速度25m/min (Example) 25: Rotary line speed 25m/min			
⑦	滚筒长度 Drum length	(例) 400: 总长度400mm (筒体加两端盖不包括出轴) (Example) 400: Total length 400mm (Barrel with two cover, without shaft)			
⑧	额定功率 Rated power	(例) 40: 电机额定功率40W (Example) 40: Motor rated power 40W			
⑨	电压类型 Voltage type	1: 单相交流电 1: Single-phase alternating current		3: 三相交流电 3: Three-phase alternating current	
⑩	电压 Voltage	(例) 380:380V 50/60Hz 通用 (Example) 380:380V 50/60Hz universal			
⑪	出线方式 Lead wire type	空缺表示直出 (可省略) Vacancy means straight connector (omissible)	G1: 接线端子盒 G1: Terminal box	G2: 弯式出线 G2: Elbow connector	G3: 不锈钢弯式出线 G3: Stainless elbow connector
⑫	附带装置 Additional device	空缺表示没附带装置 Vacancy means no additional devices	R: 逆止器 R: Back stop	M: 电磁制动器 M: Electromagnetic brake	ZV: 可垂直或倾斜安装 ZV: Can be vertically or inclined installed P: 热保护器 P: Thermal protector

一般技术信息——交流电动滚筒 GENERAL TECHNICAL INFORMATION——AC DRUM MOTOR

产品说明 Product Description

- 电动滚筒是一种将电机和减速器共同置于滚筒内部的新型驱动装置。它主要应用于固定式和移动式带式的输送机，替代传统的电动机、减速器在驱动滚筒之外的分离式驱动装置。
- 电动滚筒可在大小颗粒负荷严重的环境中运行，可抵御水流和水雾，可抵御大多数侵蚀性环境条件。由于防护等级达到IP66及其不锈钢材质(按需提供)，电动滚筒也适用于食品加工、制药等行业。
- 电动滚筒由交流异步感应电机驱动，适用大多数国际通用电压，也可根据客户要求定制。
- 电动滚筒内包含作为润滑剂和冷却剂的油，散热方式为通过滚筒外壳和传送带来散热。当使用不含传送带的电动滚筒时，可以进行特殊设计，以便确保冷却。
- Electric roller is a new type of drive device which is placed in the roller body together with the motor and the reducer. It is mainly used in fixed and movable type belt conveyor, to replace traditional type, which motor, gearbox are separated with drum
- Electric drum can run under severe particulates environment; can withstand the flow of water and spray, can resist most of the erosion environment. Due to the protection level IP66 and stainless steel material (as required), electric roller also applied to food processing, pharmaceutical and other industries.
- Electric drum driven by AC asynchronous induction motor, suitable for most of the international common voltage, also can be customized according to customer requirements.
- The electric roller contains oil as a lubricant and coolant, heat dissipation through the roller shell and the transfer of heat. When using an electric drum without a conveyor belt, a special design can be carried out to ensure that the cooling.

选项 Option

- 集成过热保护: 在电机绕组端部集成恒温保护开关。当电机过热时，开关启动。不过，开关必须连接到一个合适的外部控制器，该控制器在过热的情况下可以中断电流输送到电机。
- 集成电磁制动器: 集成的电磁制动器可以延缓和停止相对于给定的传送带引力所受的重压。它将直接对电动滚筒的转轴施加影响，由直流电整流器驱动。
- 机械防倒转装置: 安装在转轴上的机械防倒转装置可用于上升输送机。在电流中断的情况下，它可以抑制传送带向后运行。
- 旋转编码器: 旋转编码器的脉冲可以用于定位和控制速度以及旋转方向。
- Integrated thermal protection: integrated constant temperature protection switch in the motor winding end. When the motor is over heat, the switch is switched on. However, the switch must be connected to a suitable external controller, the controller can interrupt the current conveyor to the motor in case of overheating.
- Integrated electromagnetic brakes: the integrated electromagnetic brake can delay and stop the weight of the given conveyor belt. It will directly affect the axis of the electric roller, driven by DC electric rectifier.
- Mechanical anti reversing device: a mechanical anti reversing device mounted on a rotating shaft can be used to increase the conveyer. In the case of current interruption, it can inhibit the transfer of the backward running.
- Rotary encoder: the pulse can be used to position and control the speed and direction of rotation.

技术参数 Technical Parameters

保护等级 Protection Level	IP66
普通应用情况的环境温度范围 Ambient temperature range for general application	+5°C至+40°C
低温应用情况的环境温度范围 Environmental temperature range of low temperature application	-25°C至+15°C
节拍时间 Cycle time	每分钟最多3次启/停 使用变频器或采用特殊结构时，节拍时间可能更高 Start / stop at most 3 times per minute Using frequency converter or the use of special structure, the time may be higher
安装高度 Mounting height	最大海拔1000m Maximum elevation 1000m

根据环境温度的不同，必须采用不同型号的润滑油。当环境温度低于+5°C时，建议采用静止加热。当温度低于-20°C时，必须使用特殊的轴封和电缆。

According to the different environmental temperature, different types of lubricating oil must be used. When the ambient temperature is lower than +5°C, it is recommended to use static heating. When the temperature is lower than -20°C, must use special seal and cable.

恒温保护 Constant Temperature Protection

在正常运行条件下，定子绕组中集成的热断路器已关闭。当电机达到边缘温度(过热)时，转换开关以预定的温度打开(取决于绕组的绝缘等级)，用于防止损坏电机。

Under normal operating conditions, the stator winding in the integrated thermoelectric circuit breaker has been closed. When the motor reaches the edge temperature (over temperature), the switch is opened at a predetermined temperature (depending on the insulation level of the winding), which is used to prevent damage to the motor.

警告 Warning

当电机冷却后，热断路器将自动复位。

- 热断路器必须通过适合的继电器或一系列电流接触器进行转换连接。• 开关触发后，请等待至电机冷却下来。再次接通前，确保人员及设备的安全。
When the motor cooling, the thermal power circuit breaker will automatically reset.

- Thermoelectric breakers must be converted to a series of current contacts for a relay or a series of electric current. • After the switch is triggered, wait until the motor cools down. To ensure the safety of personnel and equipment before the connection.

一般技术信息——交流电动滚筒 GENERAL TECHNICAL INFORMATION——AC DRUM MOTOR

在60Hz线路中使用50Hz电机 50Hz Motor Used In 60Hz Line

- 电机额定电压: 220/380V - 3相 - 50Hz
线路电压: 220/380V - 3相 - 60Hz

Motor rated voltage: 220/380V - 3 phase - 50Hz
Line voltage: 220/380V - 3 phase - 60Hz

如果一个50Hz的电机连接到60Hz线路中，频率将增大且速度增加20%。为了保持电机其他额定参数恒定不变，输入电压需增加20%。如果未输入增大20%的电压，根据下表，与电压相关的参数将发生变化：

If a 50Hz motor is connected to the 60Hz line, the frequency will be increased and the speed of the motor is increased by 20%. In order to keep the motor constant, the input voltage should be increased by 20%. If no input is increased by 20%, the parameters will be changed according to the following table:

线路电压 = 电机额定电压 Line Voltage = Motor Rated Voltage			
功率 Power	P	kW	100%
额定转速 Rated speed	n_n	U/min	120%
额定扭矩 Rated torque	M_n	Nm	83.3%
启动扭矩 Starting torque	M_A	Nm	64%
牵引扭矩 Traction torque	M_S	Nm	64%
停转转矩 Stop torque	M_k	Nm	64%
额定电流 Rated current	I_N	A	95%
峰值电流 Peak current	I_A	A	80%
功率因数 Power factor	$\cos\Phi$	-	106%
效率 Efficiency	η	-	99.5%

- 电机额定电压: 220/380V - 3相 - 50Hz
线路电压: 264/456V - 3相 - 60Hz - 2&4极 (电机电压+20%)

Motor rated voltage: 220/380V - 3 phase - 50Hz
Line voltage: 264/456V - 3 phase - 60Hz - 2&4 (motor voltage + 20%)

如果电压增加20%在一个60Hz线路中运行50Hz电机，频率将增大且转速增加20%。电机额定参数只产生较小偏差。如果输入电压相对于电机电压而言增加15%，实际电机功率将减小到原电机功率的92%。

If the voltage is increased by 20% in a 60Hz line running 50Hz motor, the frequency will be increased and the speed of the 20% is increased. Motor ratings are only small deviations. If the input voltage is 15% to the motor voltage, the actual motor power will be reduced to 92% of the original motor power.

线路电压 = 1.2x电机额定电压 (适用于极数2和4) Line Voltage = 1.2 x Motor Rated Voltage (Applicable To 2 And 4)			
功率 Power	P	kW	100%
额定转速 Rated speed	n_n	U/min	120%
额定扭矩 Rated torque	M_n	Nm	100%
启动扭矩 Starting torque	M_A	Nm	100%
牵引扭矩 Traction torque	M_S	Nm	100%
停转转矩 Stop torque	M_k	Nm	100%
额定电流 Rated current	I_N	A	120%
峰值电流 Peak current	I_A	A	100%
功率因数 Power factor	$\cos\Phi$	-	100%
效率 Efficiency	η	-	98%

DM60电动滚筒 DM60 DRUM MOTOR

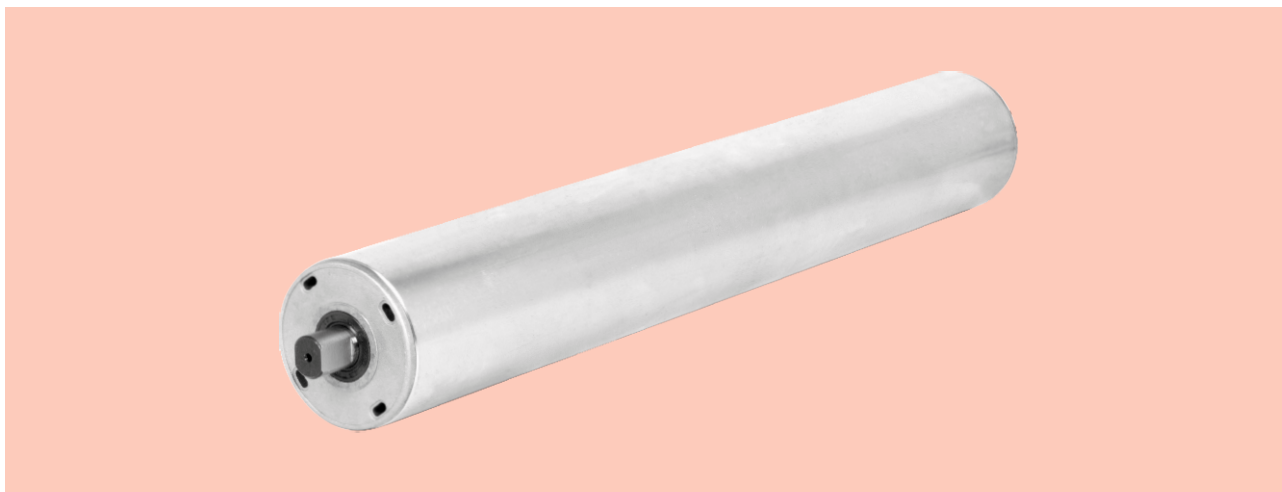

产品信息 Product Information

此款电动滚筒是空间有限，高扭矩的场合理想化选择，采用高合金钢精磨齿轮和行星传动结构为主体设计，具有性能可靠、免维护、免加油、适合较小的安装空间等诸多优点。适用于多个领域：

This type of drum motor can be installed in limited space and meet the torque requirement. Using alloy steel grinded gears and planetary transmission structure, it is reliable, free of maintenance and oil-renewing, space-saving. It can be use in many fields:

- 超市收银台 Supermarket cashier
- 包装机械 Packaging machinery
- 皮带输送线 Belt conveyor line

DM60电动滚筒特征 DM60 Characteristics Of Drum Motor

● 筒体 Drum Shell

- 标准筒体为低碳钢材质 • 食品级筒体为304不锈钢
- Material of standard drum shell is mild steel • Food grade shell is 304 stainless steel

● 齿轮传动 Gear Drive

- 高合金钢精磨齿轮 • 行星齿轮传动
- High alloy steel precision • Planetary gear transmission

● 齿轮箱 Gearbox

- 确保传动时低噪音，采用新型聚合物行星轮和金属齿轮组合变速箱
- Ensure the transmission with low noise, using the new polymer planet wheel and metal gear transmission

● 电机 Motor

- 频率在50Hz或60Hz时，适用于全球各种通用电压 • 电机绝缘等级F级 • 所有电机附带热保护器 • 散放线，出线长度0.5米
- When 50Hz or 60Hz is used, it can be applied to all kinds of universal voltage • Motor insulation class F • All motor with thermal protection • Loose wire, outlet length 0.5M

● 密封等级 Seal Level

- 轴端采用骨架油封密封 • 电动滚筒的密封防护等级为IP40/IP54
- Shaft end use of skeleton oil seal • Drum motor sealing protection level is IP40/IP54

● 注油 Oiling

- 出厂前都已按标准加注油脂，使用后免维护，无需再加注
- Before leaving factory, all products is filled will oil in standard amount, so no need of maintenance or oil-renew

● 其他 Other

- 适合多个方向安装 • 可以加装电磁制动器，但筒体的最短长度会相应加长 • 单相可以加装调速器，但不影响筒体的最短长度 • 根据客户要求，可制作各种非标准电动滚筒
- Able to be installed in multiple direction • Able to work with electromagnctic brake, but the length will be longer • Single-phase motor can work with speed control • All customized requirement can be considered

DM60单相电机机械参数 DM60 Single Phase Motor Mechanical Parameters

P_N kW	np	gs	i	v m/min	n_A min ⁻¹	M_A Nm	F_N N	SL _{最小值} mm
0.035	2	1	3.6500	129.107	684.9	0.40	14	350
			5.3600	87.918	466.4	0.60	21	350
			6.5500	71.945	381.7	0.80	25	350
			8.6300	54.605	289.7	1.00	33	350
		2	13.530	34.829	184.8	1.40	47	350
			18.920	24.907	132.1	2.00	66	350
			24.650	19.117	101.4	2.60	86	350
			28.050	16.800	89.10	2.90	97	350
			33.920	13.893	73.70	3.50	118	350
			44.690	10.545	55.90	4.70	155	350
			58.220	8.094	42.90	6.10	202	350
			3	67.080	7.025	37.30	6.30	210
		81.110		5.810	30.80	7.60	254	350
		91.360		5.158	27.40	8.60	286	350
		102.88		4.580	24.30	9.70	322	350
		118.98		3.961	21.00	11.2	372	350
		127.74		3.689	19.60	12.0	400	350
		145.36		3.242	17.20	13.6	455	350
		191.56		2.460	13.10	18.0	599	350
		231.61		2.035	10.80	21.7	725	350

DM60三相电机机械参数 DM60 Three Phase Motor Mechanical Parameters

P_N kW	np	gs	i	v m/min	n_A min ⁻¹	M_A Nm	F_N N	SL _{最小值} mm
0.040	2	1	3.6500	129.107	684.9	0.50	16	350
			5.3600	87.918	466.4	0.70	24	350
			6.5500	71.945	381.7	0.90	29	350
			8.6300	54.605	289.7	1.10	38	350
		2	13.530	34.829	184.8	1.60	54	350
			18.920	24.907	132.1	2.30	75	350
			24.650	19.117	101.4	2.90	98	350
			28.050	16.800	89.10	3.30	111	350
			33.920	13.893	73.70	4.00	135	350
			44.690	10.545	55.90	5.30	177	350
			58.220	8.094	42.90	6.90	231	350
			3	67.080	7.025	37.30	7.20	240
		81.110		5.810	30.80	8.70	290	350
		91.360		5.158	27.40	9.80	327	350
		102.88		4.580	24.30	11.0	368	350
		118.98		3.961	21.00	12.8	425	350
		127.74		3.689	19.60	13.7	457	350
		145.36		3.242	17.20	15.6	520	350
		191.56		2.460	13.10	20.5	685	350
		231.61		2.035	10.80	24.8	828	350

P_N : 额定功率 Rated power

i: 减速比 Reduction ratio of

M_A : 电动滚筒额定扭矩 Electric drum rated torque

np: 级数 Series

v: 外管额定速率 Outside the rated speed

F_N : 牵引力 Traction force

gs: 齿轮级数 Gear series

n_A : 外管额定转速 Outer tube rated speed

SL_{最小值}: 最短外管长度 The shortest outer tube length

DM60外形图 DM60 Outlining Dimensions

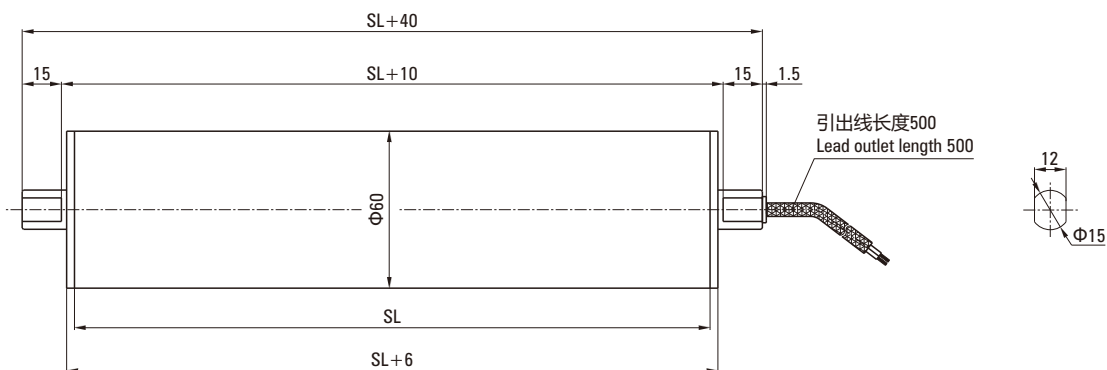

DM60安装图 DM60 Installation Diagram

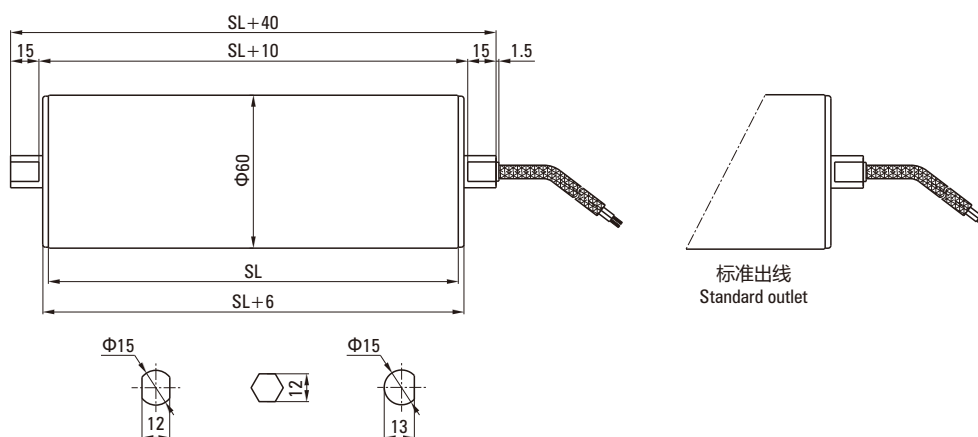

DM60选项表-电动滚筒 DM60 Option - Drum Motor

部件说明 Component Description	电动滚筒 Drum Motor
筒体 Drum shell	
碳钢直式筒体 Carton steel straight drum	1
不锈钢 (标准304) 直式筒体 Stainless steel (standard 304) straight drum	2
前后端盖 Front end cover	
铸铝端盖 Cast aluminum cover	1
镀镍铸铝端盖 Nickel plated aluminum cover	2
不锈钢 (标准304) 端盖 Stainless steel (standard 304) end cover	2
前后轴 Front and rare shaft	
碳钢轴 Carbon steel shaft	1
不锈钢轴 Stainless steel shaft	2
电机 Motor	
单相或三相异步电动机 Single phase or three phase asynchronous motor	1
电压1*220V/50Hz或3*380V/50Hz Voltage 1*220V/50Hz or 3*380V/50Hz	1
50Hz或60Hz条件下的全球通用电压 Global common voltage under 50Hz or 60Hz conditions	1
加装电机过热保护器 Thermal protector	1
常温环境用油脂 Oil for room temperature	2
电气连接 Electrical connection	
直式引出 Straight connector	1
其他选项 Other options	
电磁制动器 Electromagnetic brake	2
可不同方位安装 Can be installed in different directions	1
连接变频器 Connected converter	2
单相可接调速器 Single phase can work with speed controller	2
双铣扁出轴 Double flat shaft	1
D型轴出轴 D shape shaft	2
六角型轴出轴 Six angle type shaft out shaft	2

备注Note:

1-标准装配选项
1-Standard option

2-非标准常用选项
2-Non-standard option

3-限制性选项，选择时应与制造商确认
3-Restrained option, contact manufacturer if needed

DM70电动滚筒 DM70 DRUM MOTOR

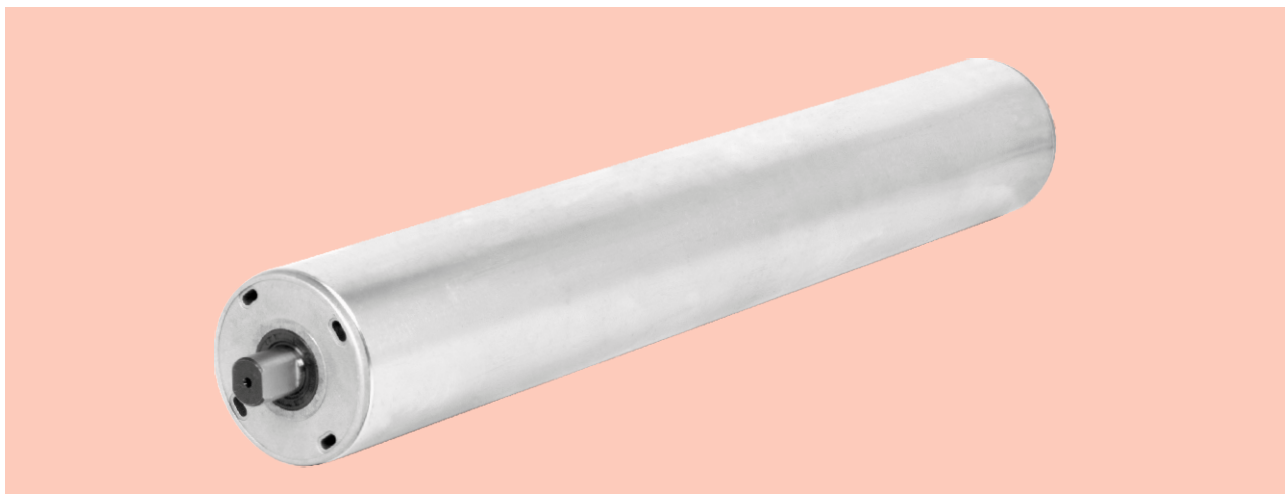

产品信息 Product Information

此款电动滚筒是空间有限，高扭矩的场合理想化选择，采用高合金钢精磨齿轮和行星传动结构为主体设计，具有性能可靠、免维护、免加油、适合较小的安装空间等诸多优点。适用于多个领域：

This type of drum motor can be installed in limited space and meet the torque requirement. Using alloy steel grinded gears and planetary transmission structure, it is reliable, free of maintenance and oil-renewing, space-saving. It can be use in many fields:

- 超市收银台 Supermarket cashier
- 包装机械 Packaging machinery
- 皮带输送线 Belt conveyor line

DM70电动滚筒特征 DM70 Characteristics Of Drum Motor

● 筒体 Drum Shell

- 标准筒体为低碳钢材质 • 食品级筒体为304不锈钢
- Material of standard drum shell is mild steel • Food grade shell is 304 stainless steel

● 齿轮传动 Gear Drive

- 高合金钢精磨齿轮 • 行星齿轮传动
- High alloy steel precision • Planetary gear transmission

● 齿轮箱 Gearbox

- 确保传动时低噪音，采用新型聚合物行星轮和金属齿轮组合变速箱
- Ensure the transmission with low noise, using the new polymer planet wheel and metal gear transmission

● 电机 Motor

- 频率在50Hz或60Hz时，适用于全球各种通用电压 • 电机绝缘等级F级 • 所有电机附带热保护器 • 散放线，出线长度0.5米
- When 50Hz or 60Hz is used, it can be applied to all kinds of universal voltage • Motor insulation class F • All motor with thermal protection • Loose wire, outlet length 0.5M

● 密封等级 Seal Level

- 轴端采用骨架油封密封 • 电动滚筒的密封防护等级为IP40/IP54
- Shaft end use of skeleton oil seal • Drum motor sealing protection level is IP40/IP54

● 注油 Oiling

- 出厂前都已按标准加注油脂，使用后免维护，无需再加注
- Before leaving factory, all products is filled will oil in standard amount, so no need of maintenance or oil-renew

● 其他 Other

- 适合多个方向安装 • 可以加装电磁制动器，但筒体的最短长度会相应加长 • 单相可以加装调速器，但不影响筒体的最短长度 • 根据客户要求，可制作各种非标准电动滚筒
- Able to be installed in multiple direction • Able to work with electromagnetic brake, but the length will be longer • Single-phase motor can work with speed control • All customized requirement can be considered

DM70单相电机机械参数 DM70 Single Phase Motor Mechanical Parameters

P_N kW	np	gs	i	v m/min	n_A min ⁻¹	M_A Nm	F_N N	SL _{最小值} mm				
0.06	2	1	3.6500	150.624	684.9	0.70	21	350				
			5.3600	102.571	466.4	1.10	30	350				
			6.5500	83.936	381.7	1.30	37	350				
			8.6300	63.706	289.7	1.70	49	350				
		2	2	13.530	40.634	184.8	2.40	69	350			
				18.920	29.058	132.1	3.40	96	350			
				24.650	22.303	101.4	4.40	126	350			
				28.050	19.600	89.10	5.00	143	350			
				33.920	16.208	73.70	6.10	173	350			
				44.690	12.302	55.90	8.00	228	350			
				58.220	9.443	42.90	10.4	297	350			
				3	3	67.080	8.196	37.30	10.8	308	360	
						81.110	6.778	30.80	13.0	373	360	
						91.360	6.018	27.40	14.7	420	360	
		102.88	5.344			24.30	16.6	473	360			
		118.98	4.621			21.00	19.1	547	360			
		127.74	4.304			19.60	20.6	587	360			
		145.36	3.782			17.20	23.4	668	360			
		165.64	3.319			15.10	26.6	761	360			
		191.56	2.870			13.10	30.8	881	360			
		231.61	2.374			10.80	37.3	1065	360			
		0.09	2			1	3.6500	150.624	684.9	1.10	31	360
							5.3600	102.571	466.4	1.60	46	360
							6.5500	83.936	381.7	1.90	56	360
							8.6300	63.706	289.7	2.60	73	360
				2	2	13.530	40.634	184.8	3.60	104	360	
						18.920	29.058	132.1	5.10	145	360	
						24.650	22.303	101.4	6.60	189	360	
28.050	19.600					89.10	7.50	215	360			
33.920	16.208					73.70	9.10	260	360			
44.690	12.302					55.90	12.0	342	360			
58.220	9.443					42.90	15.6	445	360			
3	3					67.080	8.196	37.30	16.2	463	360	
						81.110	6.778	30.80	19.6	559	360	
						91.360	6.018	27.40	22.0	630	360	
				102.88	5.344	24.30	24.8	709	360			
				118.98	4.621	21.00	28.7	820	360			
				127.74	4.304	19.60	30.8	881	360			
				145.36	3.782	17.20	35.1	1002	360			
				165.64	3.319	15.10	40.0	1142	360			
				191.56	2.870	13.10	46.2	1321	360			
				231.61	2.374	10.80	55.9	1597	360			

P_N : 额定功率 Rated power

i: 减速比 Reduction ratio of

M_A : 电动滚筒额定扭矩 Electric drum rated torque

np: 级数 Series

v: 外管额定速率 Outside the rated speed

F_N : 牵引力 Traction force

gs: 齿轮级数 Gear series

n_A : 外管额定转速 Outer tube rated speed

SL_{最小值}: 最短外管长度 The shortest outer tube length

DM70三相电机机械参数 DM70 Three Phase Motor Mechanical Parameters

P_N kW	np	gs	i	v m/min	n_A min ⁻¹	M_A Nm	F_N N	SL _{最小值} mm			
0.06	2	1	3.6500	150.624	684.9	0.70	21	350			
			5.3600	102.571	466.4	1.10	30	350			
			6.5500	83.936	381.7	1.30	37	350			
			8.6300	63.706	289.7	1.70	49	350			
		2	2	13.530	40.634	184.8	2.40	69	350		
				18.920	29.058	132.1	3.40	96	350		
				24.650	22.303	101.4	4.40	126	350		
				28.050	19.600	89.10	5.00	143	350		
				33.920	16.208	73.70	6.10	173	350		
				44.690	12.302	55.90	8.00	228	350		
				58.220	9.443	42.90	10.4	297	350		
				3	67.080	8.196	37.30	10.8	308	360	
					81.110	6.778	30.80	13.0	373	360	
					91.360	6.018	27.40	14.7	420	360	
		102.88	5.344		24.30	16.6	473	360			
		118.98	4.621		21.00	19.1	547	360			
		127.74	4.304		19.60	20.6	587	360			
		145.36	3.782		17.20	23.4	668	360			
		165.64	3.319		15.10	26.6	761	360			
		191.56	2.870		13.10	30.8	881	360			
		231.61	2.374		10.80	37.3	1065	360			
		0.09	2		1	3.6500	150.624	684.9	1.10	31	350
						5.3600	102.571	466.4	1.60	46	350
						6.5500	83.936	381.7	1.90	56	350
						8.6300	63.706	289.7	2.60	73	350
				2	2	13.530	40.634	184.8	3.60	104	350
						18.920	29.058	132.1	5.10	145	350
						24.650	22.303	101.4	6.60	189	350
28.050	19.600					89.10	7.50	215	350		
33.920	16.208					73.70	9.10	260	350		
44.690	12.302					55.90	12.0	342	350		
58.220	9.443					42.90	15.6	445	350		
3	67.080					8.196	37.30	16.2	463	360	
	81.110					6.778	30.80	19.6	559	360	
	91.360					6.018	27.40	22.0	630	360	
	102.88			5.344	24.30	24.8	709	360			
	118.98			4.621	21.00	28.7	820	360			
	127.74			4.304	19.60	30.8	881	360			
	145.36			3.782	17.20	35.1	1002	360			
	165.64			3.319	15.10	40.0	1142	360			
	191.56			2.870	13.10	46.2	1321	360			
	231.61			2.374	10.80	55.9	1597	360			

P_N : 额定功率 Rated power

i: 减速比 Reduction ratio of

M_A : 电动滚筒额定扭矩 Electric drum rated torque

np: 级数 Series

v: 外管额定速率 Outside the rated speed

F_N : 牵引力 Traction force

gs: 齿轮级数 Gear series

n_A : 外管额定转速 Outer tube rated speed

SL_{最小值}: 最短外管长度 The shortest outer tube length

DM70外形图 DM70 Outlining Dimensions

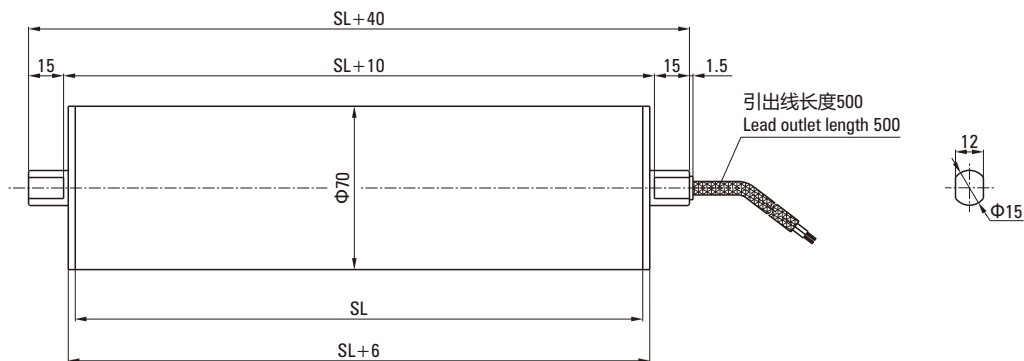

DM70安装图 DM70 Installation Diagram

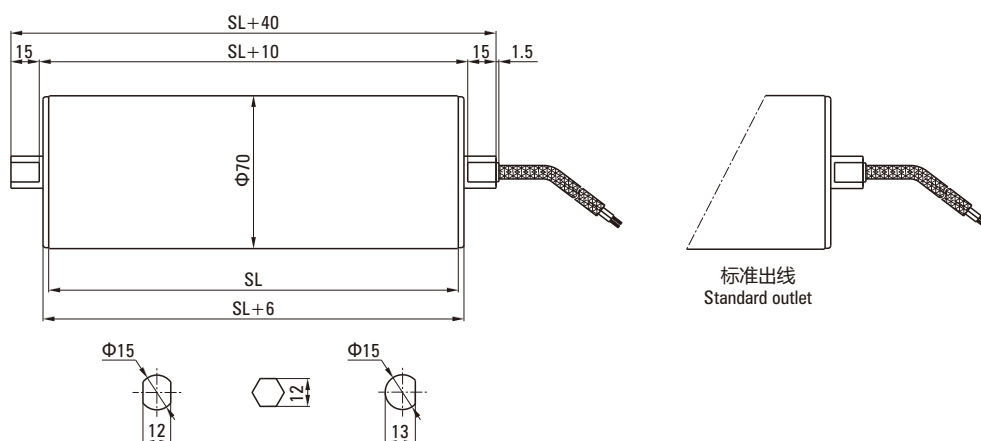

DM70选项表-电动滚筒 DM70 Option - Drum Motor

部件说明 Component Description	电动滚筒 Drum Motor
筒体 Drum shell	
碳钢直式筒体 Carton steel straight drum	1
不锈钢 (标准304) 直式筒体 Stainless steel (standard 304) straight drum	2
前后端盖 Front end cover	
铸铝端盖 Cast aluminum cover	1
镀镍铸铝端盖 Nickel plated aluminum cover	2
不锈钢 (标准304) 端盖 Stainless steel (standard 304) end cover	2
前后轴 Front and rare shaft	
碳钢轴 Carbon steel shaft	1
不锈钢轴 Stainless steel shaft	2
电机 Motor	
单相或三相异步电动机 Single phase or three phase asynchronous motor	1
电压1*220V/50Hz或3*380V/50Hz Voltage 1*220V/50Hz or 3*380V/50Hz	1
50Hz或60Hz条件下的全球通用电压 Global common voltage under 50Hz or 60Hz conditions	1
加装电机过热保护器 Thermal protector	1
常温环境用油脂 Oil for room temperature	2
电气连接 Electrical connection	
直式引出 Straight connector	1
其他选项 Other options	
电磁制动器 Electromagnetic brake	2
可不同方位安装 Can be installed in different directions	1
连接变频器 Connected converter	2
单相可接调速器 Single phase can work with speed controller	2
双铣扁出轴 Double flat shaft	1
D型轴出轴 D shape shaft	2
六角型轴出轴 Six angle type shaft out shaft	2

备注Note:

1-标准装配选项
1-Standard option

2-非标准常用选项
2-Non-standard option

3-限制性选项，选择时应与制造商确认
3-Restrained option, contact manufacturer if needed

DM80电动滚筒 DM80 DRUM MOTOR

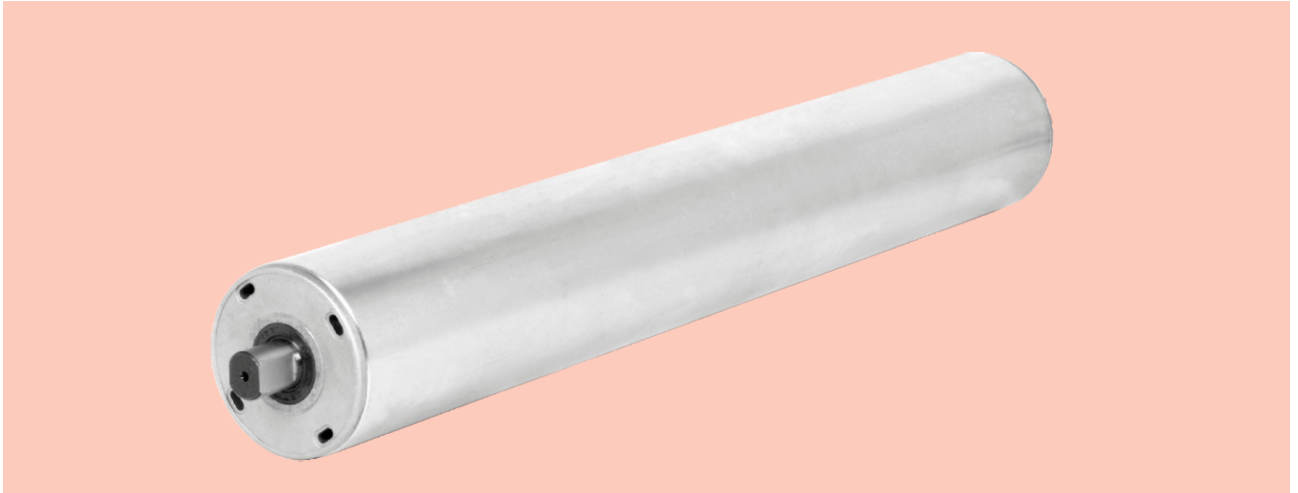

产品信息 Product Information

此款电动滚筒是在空间有限或操作不便的高扭矩应用的理想化选择，采用高合金钢精磨齿轮和行星传动结构为主体设计，具有性能可靠、免维护、适合较小的安装空间及超低噪声等诸多优点。适用于多个领域：

This type of drum motor can be installed in limited space and meet the torque requirement. Using alloy steel grinded gears and planetary transmission structure, it is reliable, free of maintenance and oil-renewing, space-saving. It can be use in many fields:

- | | |
|----------|----------------------------|
| • 超市收银台 | Supermarket cashier |
| • 安检机 | Security machine |
| • 包装机械 | Packaging machinery |
| • 食品加工工业 | Food processing industry |
| • 皮带输送线 | Belt conveyor line |
| • 动态称重设备 | Dynamic weighing apparatus |

DM80电动滚筒特征 DM80 Characteristics Of Drum Motor

● 筒体 Drum Shell

- 标准筒体为低碳钢材质，成品表面镀锌，做环保标志 • 食品级筒体为304不锈钢
- Material of standard drum shell is mild steel, zinc plated, with ECO mark • Food garde shell is 304 stainless steel

● 齿轮传动 Gear Drive

- 高合金钢精磨齿轮或二次刮削 • 行星齿轮传动
- High alloy steel grinding or scraping gear two • Planetary gear transmission

● 齿轮箱 Gearbox

- 确保传动时低噪音，采用新型聚合物行星轮和金属齿轮组合变速箱
- Ensure the transmission with low noise, using the new polymer planet wheel and metal gear transmission

● 电机 Motor

- 频率在50Hz或60Hz时，适用于全球各种通用电压 • 电机绝缘等级F级 • 所有电机附加过热保护器 • 散线出线式，电缆的标准长度0.5米
- When 50Hz or 60Hz is used, it can be applied to all kinds of universal voltage • Motor insulation class F • All motor additional overheat protector • Cable outlet type, cable length of 0.5M

● 密封等级 Seal Level

- 轴端采用骨架油封密封 • 电动滚筒的密封防护等级为IP54
- Shaft end seal with skeleton oil seal • The seal protection level of the drum motor is IP54

● 注油 Oiling

- 出厂前都已按标准加注油脂，使用后免维护，无需再加注
- Before leaving factory, all products is filled will oil in standard amount, so no need of maintenance or oil-renew

● 其他 Other

- 水平安装 • 可以加装电磁制动器，但筒体的最短长度会相应加长 • 带速及筒体长度可按客户要求制作 • 根据客户要求，可制作各种非标准电动滚筒
- Horizontal installation • Can be equipped with electromagnetic brake, but the shortest length of the cylinder will be extended accordingly • Belt speed and tube length can be produced according to customer requirements • According to customer requirements, can produce a variety of non - standard electric roller

DM80单相电机机械参数 DM80 Single Phase Motor Mechanical Parameters

P_N kW	np	gs	i	v m/min	n_A min ⁻¹	M_A Nm	F_N N	SL _{最小值} mm					
0.09	2	1	3.6500	175.370	684.9	1.10	27	350					
			5.3600	119.422	466.4	1.60	40	350					
			6.5500	97.725	381.7	1.90	49	350					
			8.6300	74.171	289.7	2.60	64	350					
		2	2	2	13.530	47.310	184.8	3.60	91	380			
					18.920	33.832	132.1	5.10	127	380			
					24.650	25.968	101.4	6.60	165	380			
					28.050	22.820	89.10	7.50	188	380			
					33.920	18.871	73.70	9.10	227	380			
					44.690	14.323	55.90	12.0	299	380			
					58.220	10.994	42.90	15.6	390	380			
					3	3	3	67.080	9.542	37.30	16.2	405	400
								81.110	7.892	30.80	19.6	489	400
								91.360	7.006	27.40	22.0	551	400
		102.88	6.222	24.30				24.8	621	400			
		118.98	5.380	21.00				28.7	718	400			
		127.74	5.011	19.60				30.8	771	400			
		145.36	4.404	17.20				35.1	877	400			
		165.64	3.864	15.10				40.0	999	400			
		191.56	3.342	13.10				46.2	1156	400			
		231.61	2.764	10.80				55.9	1397	400			
		0.12	2	1				3.6500	175.370	684.9	1.40	36	350
								5.3600	119.422	466.4	2.10	53	350
								6.5500	97.725	381.7	2.60	65	350
								8.6300	74.171	289.7	3.40	86	350
				2	2	2	13.530	47.310	184.8	4.80	121	380	
							18.920	33.832	132.1	6.80	169	380	
							24.650	25.968	101.4	8.80	220	380	
28.050	22.820						89.10	10.0	250	380			
33.920	18.871						73.70	12.1	303	380			
44.690	14.323						55.90	16.0	399	380			
58.220	10.994						42.90	20.8	520	380			
3	3						3	67.080	9.542	37.30	21.6	540	400
								81.110	7.892	30.80	26.1	652	400
								91.360	7.006	27.40	29.4	735	400
				102.88	6.222	24.30		33.1	828	400			
				118.98	5.380	21.00		38.3	957	400			
				127.74	5.011	19.60		41.1	1028	400			
				145.36	4.404	17.20		46.8	1169	400			
				165.64	3.864	15.10		53.3	1332	400			
				191.56	3.342	13.10		61.6	1541	400			
				231.61	2.764	10.80		74.5	1863	400			

P_N : 额定功率 Rated power

i: 减速比 Reduction ratio of

M_A : 电动滚筒额定扭矩 Electric drum rated torque

np: 级数 Series

v: 外管额定速率 Outside the rated speed

F_N : 牵引力 Traction force

gs: 齿轮级数 Gear series

n_A : 外管额定转速 Outer tube rated speed

SL_{最小值}: 最短外管长度 The shortest outer tube length

DM80三相电机机械参数 DM80 Three Phase Motor Mechanical Parameters

P_N kW	np	gs	i	v m/min	n_A min ⁻¹	M_A Nm	F_N N	SL _{最小值} mm					
0.09	2	1	3.6500	182.385	712.3	1.10	27	350					
			5.3600	124.198	485.1	1.60	40	350					
			6.5500	101.634	396.9	1.90	49	350					
			8.6300	77.138	301.3	2.60	64	350					
		2	2	2	13.530	49.202	192.2	3.60	91	380			
					18.920	35.185	137.4	5.10	127	380			
					24.650	27.006	105.5	6.60	165	380			
					28.050	23.733	92.70	7.50	188	380			
					33.920	19.626	76.70	9.10	227	380			
					44.690	14.896	58.20	12.0	299	380			
					58.220	11.434	44.70	15.6	390	380			
					3	3	3	67.080	9.924	38.80	16.2	405	400
								81.110	8.207	32.10	19.6	489	400
								91.360	7.287	28.50	22.0	551	400
		102.88	6.471	25.30				24.8	621	400			
		118.98	5.595	21.90				28.7	718	400			
		127.74	5.211	20.40				30.8	771	400			
		145.36	4.580	17.90				35.1	877	400			
		165.64	4.019	15.70				40.0	999	400			
		191.56	3.475	13.60				46.2	1156	400			
		231.61	2.874	11.20				55.9	1397	400			
		0.15	2	1				3.6500	182.385	712.3	1.80	45	350
								5.3600	124.198	485.1	2.70	66	350
								6.5500	101.634	396.9	3.20	81	350
								8.6300	77.138	301.3	4.30	107	350
				2	2	2	13.530	49.202	192.2	6.00	151	380	
							18.920	35.185	137.4	8.40	211	380	
							24.650	27.006	105.5	11.0	275	380	
28.050	23.733						92.70	12.5	313	380			
33.920	19.626						76.70	15.1	378	380			
44.690	14.896						58.20	19.9	499	380			
58.220	11.434						44.70	26.0	650	380			
3	3						3	67.080	9.924	38.80	27.0	674	400
								81.110	8.207	32.10	32.6	816	400
								91.360	7.287	28.50	36.7	919	400
				102.88	6.471	25.30		41.4	1034	400			
				118.98	5.595	21.90		47.9	1196	400			
				127.74	5.211	20.40		51.4	1284	400			
				145.36	4.580	17.90		58.5	1462	400			
				165.64	4.019	15.70		66.6	1666	400			
				191.56	3.475	13.60		77.0	1926	400			
				231.61	2.874	11.20		93.2	2329	400			

P_N : 额定功率 Rated power

i: 减速比 Reduction ratio of

M_A : 电动滚筒额定扭矩 Electric drum rated torque

np: 级数 Series

v: 外管额定速率 Outside the rated speed

F_N : 牵引力 Traction force

gs: 齿轮级数 Gear series

n_A : 外管额定转速 Outer tube rated speed

SL_{最小值}: 最短外管长度 The shortest outer tube length

DM80外形图 DM80 Outlining Dimensions

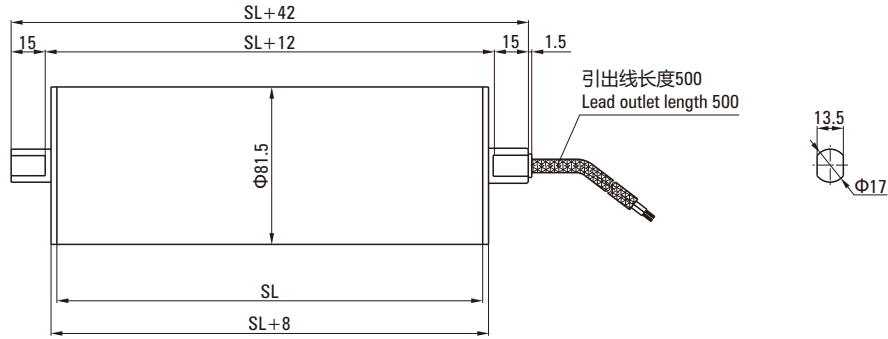

DM80安装图 DM80 Installation Diagram

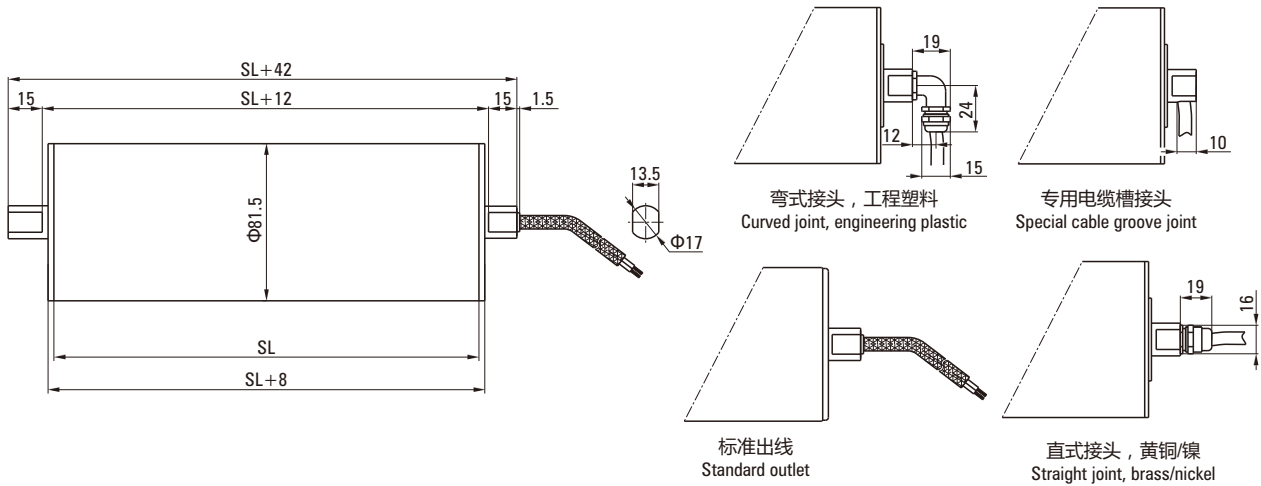

DM80选项表-电动滚筒 DM80 Option - Drum Motor

部件说明 Component Description	电动滚筒 Drum Motor
筒体 Drum shell	
碳钢直式筒体 Carton steel straight drum	1
不锈钢 (标准304) 直式筒体 Stainless steel (standard 304) straight drum	2
前后端盖 Front end cover	
铸铝端盖 Cast aluminum cover	1
镀镍铸铝端盖 Nickel plated aluminum cover	2
不锈钢 (标准304) 端盖 Stainless steel (standard 304) end cover	2
前后轴 Front and rare shaft	
碳钢轴 Carbon steel shaft	1
不锈钢轴 Stainless steel shaft	2
电机 Motor	
单相或三相异步电动机 Single phase or three phase asynchronous motor	1
电压1*220V/50Hz或3*380V/50Hz Voltage 1*220V/50Hz or 3*380V/50Hz	1
50Hz或60Hz条件下的全球通用电压 Global common voltage under 50Hz or 60Hz conditions	1
加装电机过热保护器 Thermal protector	1
常温环境用油脂 Oil for room temperature	2
电气连接 Electrical connection	
工程塑料弯式 Engineering plastic bending	3
直弯式出线 Straight curved line	1
PVC线缆 PVC cable	1
低烟无卤素线缆 Low smoke halogen free cable	2
其他选项 Other options	
电磁制止器 Electromagnetic stop device	2
可不同方位安装 Can be installed in different directions	3
连接变频器 Connected converter	2

备注Note:

1-标准装配选项
1-Standard option

2-非标准常用选项
2-Non-standard option

3-限制性选项，选择时应与制造商确认
3-Restrained option, contact manufacturer if needed

DM/DMX113电动滚筒

DM/DMX113 DRUM MOTOR

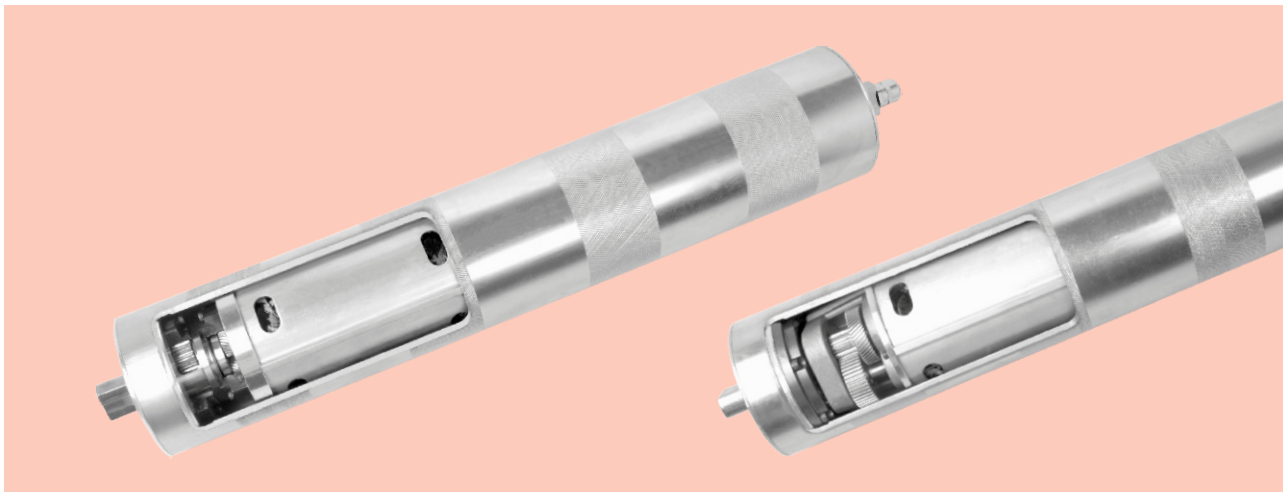

产品信息 Product Information

对传动系统的空间、低噪声和大功率有特殊要求的输送设备可使用DM113A，通过精磨高合金钢齿轮和特殊的高精度装配方法，使其在运行噪音和本产品功率要求等方面，满足客户的要求：此产品广泛用到以下行业

The transmission system of space, low noise and high power transmission equipment has special requirements for the use of DM113A, high alloy steel gear and special high precision assembly method of grinding with fine the running noise and the power requirements, meet customer requirements: This product is widely used in the following industries

- | | |
|------------|---------------------------------|
| • 安检机 | Security machine |
| • 机场行李处理系统 | Airport baggage handling system |
| • 包装机械 | Packing machinery |
| • 动力皮带秤 | Power belt scale |
| • 制药行业 | Pharmaceutical industry |
| • 食品加工工业 | Food processing industry |
| • 肉禽加工业 | Meat processing industry |
| • 邮政分拣 | Postal sorting |
| • 皮带输送机 | Belt conveyor |

DM/DMX113电动滚筒特征 DM/DMX113 Characteristics Of Drum Motor

● 筒体 Drum Shell

- 标准筒体为低碳钢材质，成品表面镀锌，做环保标志 • 食品级筒体为304不锈钢 • 标准筒体表面加工有防滑滚花
- Material of standard drum shell is mild steel, zinc plated, with ECO mark • Food grade shell is 304 stainless steel • Standard cylinder surface processing with non slip roller

● 齿轮传动 Gear Drive

- 高合金钢精磨齿轮，确保传动时超低噪音，铸铝齿轮箱 • 重载型电动滚筒采用行星齿轮传动，根据重型载荷设计，高扭矩传输
- High alloy steel grinding gear, to ensure the transmission of ultra low noise, aluminum gear box • Heavy load electric roller adopts planetary gear transmission, according to heavy load design, high torque transmission

● 电机 Motor

- 频率在50Hz或60Hz时，适用于全球各种通用电压 • 电机绝缘等级F级 • 所有电机附加过热保护器 • 电机油浸式散热 • 电缆出线式，电缆的标准长度1.2米
- When 50Hz or 60Hz is used, it can be applied to all kinds of universal voltage • Motor insulation class F • All motor additional overhear protector • Oil immersed motor cooling
- Cable outlet type, cable length of 1.2M

● 密封等级 Seal Level

- 轴端采用双密封设计 • 电动滚筒的密封防护等级为IP66/IP67
- Double seal design for shaft end • Drum motor sealing protection level is IP66/IP67

● 注油 Oiling

- 电动滚筒出厂前都已按标准注油 • 每运行5000小时换油一次
- Electric roller factory before has according to the standard oil • Every 5000 hours to run oil change time

● 其他 Other

- 水平安装 • 可以加装电磁制动器，但筒体的最短长度会相应加长 • 带速及筒体长度可按客户要求制作 • 根据客户要求，可制作各种非标准电动滚筒
- Horizontal installation • Can be equipped with electromagnetic brake, but the shortest length of the cylinder will be extended accordingly • Belt speed and tube length can be produced according to customer requirements • According to customer requirements, can produce a variety of non - standard electric roller

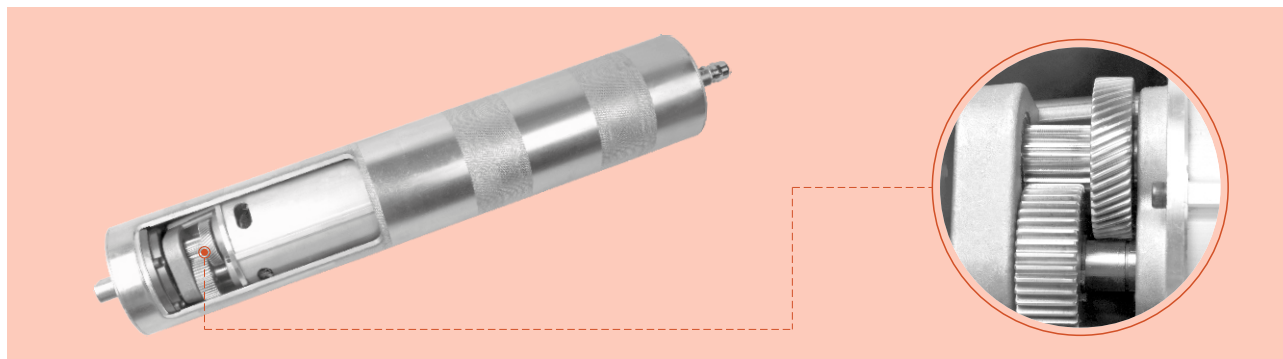

DM113三相轻载滚筒电机机械参数 DM113 Mechanical Parameters Of Three Phase Light Load Drum Motor

P_N kW	np	gs	i	v m/min	n_A min^{-1}	M_A Nm	F_N N	SL _{最小值} mm
0.18	4	2	11.28	42.49	119.7	12.8	227	280
			12.82	37.38	105.3	14.5	257	280
			15.09	31.76	89.50	17.1	303	280
		3	21.23	22.57	63.60	24.1	426	280
			24.34	19.69	55.50	27.6	489	280
			27.65	17.33	48.80	31.4	555	280
			32.69	14.66	41.30	37.1	657	280
			41.49	11.55	32.50	47.1	833	280
0.25	2	2	11.28	88.12	248.2	8.60	152	280
			12.82	77.54	218.4	9.70	172	280
			15.09	65.87	185.6	11.5	203	280
		3	21.23	46.82	131.9	16.1	286	280
			24.34	40.84	115.0	18.5	327	280
			27.65	35.95	101.3	21.0	327	280
			32.69	30.41	85.70	24.8	440	280
			41.49	23.96	67.50	31.5	558	280
0.30	4	2	11.28	42.49	119.7	21.3	378	320
			12.82	37.38	105.3	24.2	429	320
			15.09	31.76	89.50	28.5	505	320
		3	21.23	22.57	63.60	37.9	671	320
			24.34	19.69	55.50	43.5	769	320
			27.65	17.33	48.80	49.4	874	320
			32.69	14.66	41.30	58.4	1033	320
			41.49	11.55	32.50	74.1	1311	320
0.37	2	2	11.28	88.12	248.2	12.7	225	320
			12.82	77.54	218.4	14.4	255	320
			15.09	65.87	185.6	17.0	300	320
		3	21.23	46.82	131.9	22.5	399	320
			24.34	40.84	115.0	25.8	457	320
			27.65	35.95	101.3	29.4	520	320
			32.69	30.41	85.70	34.7	614	320
			41.49	23.96	67.50	44.0	780	320

P_N : 额定功率 Rated power

i: 减速比 Reduction ratio of

M_A : 电动滚筒额定扭矩 Electric drum rated torque

np: 级数 Series

v: 外管额定速率 Outside the rated speed

F_N : 牵引力 Traction force

gs: 齿轮级数 Gear series

n_A : 外管额定转速 Outer tube rated speed

SL_{最小值}: 最短外管长度 The shortest outer tube length

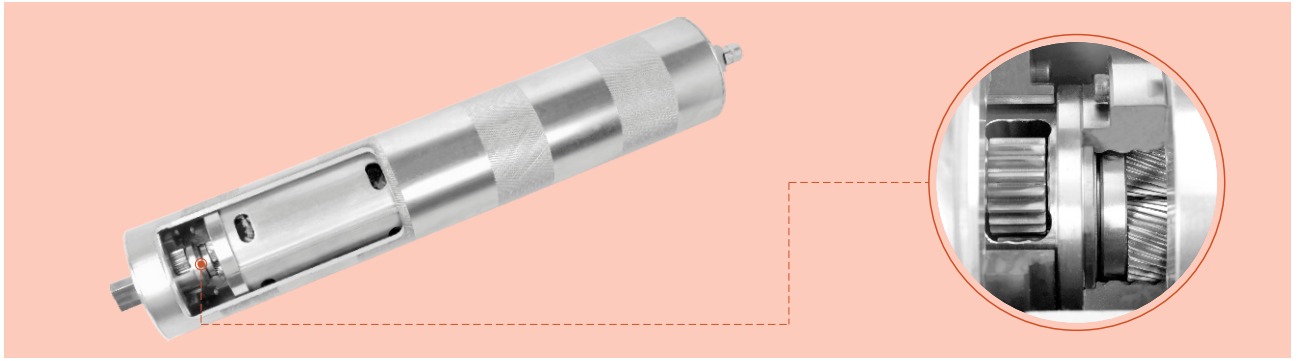

DMX113三相重载滚筒电机机械参数 DMX113 Mechanical Parameters Of Three Phase Heavy Load Drum Motor

P_N kW	np	gs	i	v m/min	n_A min^{-1}	M_A Nm	F_N N	SL _{最小值} mm
0.15	4	2	9.860	48.63	137.0	7.80	138	260
			12.01	12.07	112.4	9.60	168	260
			15.26	31.41	88.50	12.1	214	260
			17.63	27.18	76.60	14.0	247	260
			20.99	22.84	64.30	16.7	294	260
			24.66	19.44	54.80	19.6	345	260
			27.38	17.50	49.30	21.8	383	260
			30.82	15.55	43.80	24.5	432	260
			36.07	13.29	37.40	28.7	505	260
			39.70	12.07	34.00	31.6	556	260
49.62	9.660	27.20	39.5	695	260			
0.18	4	2	9.860	48.63	137.0	9.40	166	260
			12.01	12.07	112.4	11.5	202	260
			15.26	31.41	88.50	14.6	256	260
			17.63	27.18	76.60	16.8	296	260
			20.99	22.84	64.30	20.0	353	260
			24.66	19.44	54.80	23.5	414	260
			27.38	17.50	49.30	26.1	460	260
			30.82	15.55	43.80	29.4	518	260
			36.07	13.29	37.40	34.5	606	260
			39.70	12.07	34.00	37.9	667	260
49.62	9.660	27.20	47.4	834	260			
0.25	4	2	9.860	48.63	137.0	13.1	230	300
			12.01	12.07	112.4	15.9	280	300
			15.26	31.41	88.50	20.2	356	300
			17.63	27.18	76.60	23.4	412	300
			20.99	22.84	64.30	27.8	490	300
			24.66	19.44	54.80	32.7	576	300
			27.38	17.50	49.30	36.3	639	300
			30.82	15.55	43.80	40.9	719	300
			36.07	13.29	37.40	47.8	842	300
			39.70	12.07	34.00	52.7	927	300
49.62	9.660	27.20	65.8	1158	300			
0.37	4	2	9.860	48.63	137.0	19.3	340	300
			12.01	12.07	112.4	23.6	415	300
			15.26	31.41	88.50	30.0	527	300
			17.63	27.18	76.60	34.6	609	300
			20.99	22.84	64.30	41.2	725	300
			24.66	19.44	54.80	48.4	852	300
			27.38	17.50	49.30	53.7	946	300
			30.82	15.55	43.80	60.5	1065	300
			36.07	13.29	37.40	70.8	1246	300
			39.70	12.07	34.00	77.9	1372	300
49.62	9.660	27.20	97.4	1714	300			
0.55	2	2	9.860	100.86	284.1	13.9	244	300
			12.01	82.77	233.2	16.9	297	300
			15.26	65.15	183.5	21.5	378	300
			17.63	56.37	158.8	24.8	437	300
			20.99	47.36	133.4	29.5	520	300
			24.66	40.31	113.6	34.7	611	300
			27.38	36.31	102.3	38.5	678	300
			30.82	32.25	90.90	43.4	763	300
			36.07	27.55	77.60	50.8	893	300
			39.70	25.04	70.50	55.9	983	300
49.62	20.03	56.40	69.8	1229	300			

P_N : 额定功率 Rated power

i: 减速比 Reduction ratio of

M_A : 电动滚筒额定扭矩 Electric drum rated torque

np: 级数 Series

v: 外管额定速率 Outside the rated speed

F_N : 牵引力 Traction force

gs: 齿轮级数 Gear series

n_A : 外管额定转速 Outer tube rated speed

SL_{最小值}: 最短外管长度 The shortest outer tube length

DM/DMX113外形图 DM/DMX113 Outlining Dimensions

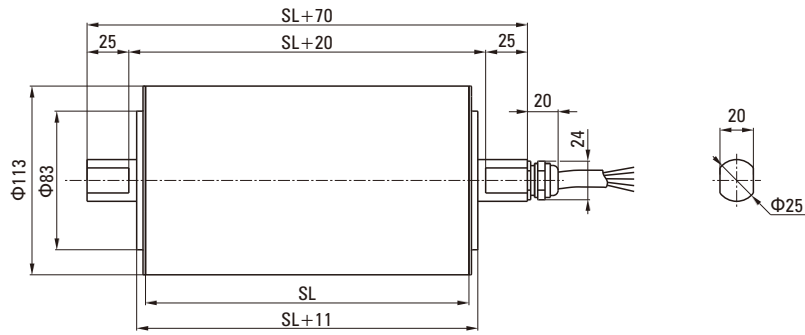

标准的滚筒长度和重量 Standard Drum Length And Weight:

外管长度 SL单位: mm Outer Tube Length SL Unit: mm	250	300	350	400	450	500	550	600	650	700	750	800	850
平均重量 单位: Kg Average Weight Unit: Kg	8.50	9.20	9.80	10.5	11.1	11.8	12.4	13.0	13.7	14.4	15.0	15.7	16.3
最大功率 (kW) Maximum Power (kW)	4P						0.37						
	2P						0.55						
最大速比 Slowest Ratio							49.62						
最小速比 Minimum Speed Ratio							9.86						

DM/DMX113安装图 DM/DMX113 Installation Diagram

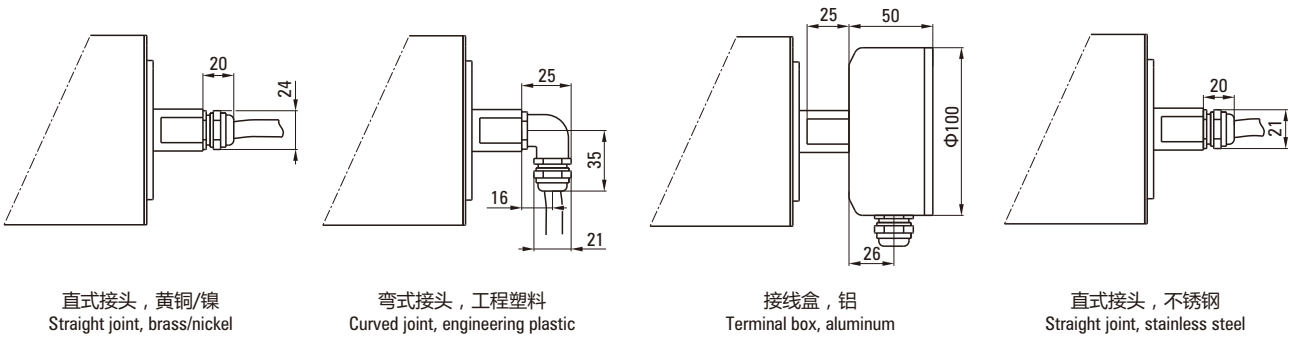

直式接头, 黄铜/镍
Straight joint, brass/nickel

弯式接头, 工程塑料
Curved joint, engineering plastic

接线盒, 铝
Terminal box, aluminum

直式接头, 不锈钢
Straight joint, stainless steel

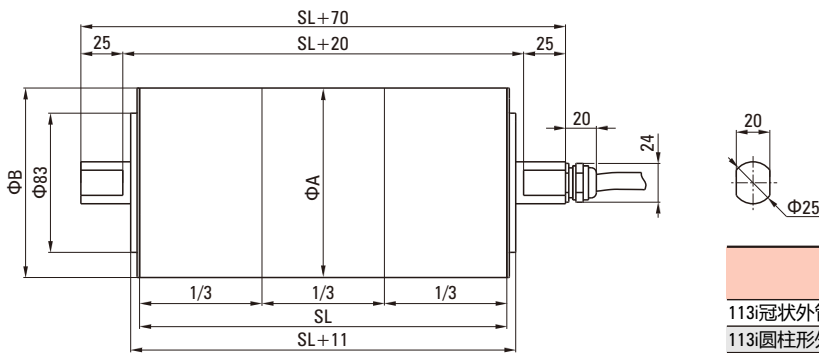

类型 Type	ΦA mm	ΦB mm
113i冠状外管 113i tube	113.5	112.0
113i圆柱形外管 113i cylindrical tube	113.0	113.0
113i圆柱形外管+键 113i cylindrical tube + key	113.0	113.0

DM/DMX113选项表-电动滚筒 DM/DMX113 Option - Drum Motor

部件说明 Component Description	电动滚筒 Drum Motor
筒体 Drum shell	
碳钢冠状筒体 Carbon steel tube body	1
碳钢直式筒体 Carton steel straight drum	2
不锈钢 (标准304) 冠状筒体 Stainless steel (standard 304) coronal tube body	2
不锈钢 (标准304) 直式筒体 Stainless steel (standard 304) straight drum	2
特殊冠状及凹槽型 Special coronal and groove type	3
前后端盖 Front end cover	
铸铝端盖 Cast aluminum cover	1
镀镍铸铝端盖 Nickel plated aluminum cover	2
不锈钢 (标准304) 端盖 Stainless steel (standard 304) end cover	2
前后轴 Front and rare shaft	
碳钢轴 Carbon steel shaft	1
不锈钢轴 Stainless steel shaft	2
电机 Motor	
单相或三相异步电动机 Single phase or three phase asynchronous motor	1
电压1*220V/50Hz或3*380V/50Hz Voltage 1*220V/50Hz or 3*380V/50Hz	1
50Hz或60Hz条件下的全球通用电压 Global common voltage under 50Hz or 60Hz conditions	1
加装电机过热保护器 Thermal protector	1
低温环境用油 Low temperature environment	2
食品级油&脂 (FDA和USDA) Food grade oil & fat (FDA and USDA)	2
电气连接 Electrical connection	
不锈钢弯头 Stainless steel elbow	3
直弯式出线 Straight curved line	1
PVC线缆 PVC cable	1
低烟无卤素线缆 Low smoke halogen free cable	2
铸铝端子盒 Cast terminal box	1
镀镍铸铝端子盒 Nickel plated aluminum terminal box	1
不锈钢端子盒 Stainless steel terminal box	2
其他选项 Other options	
电磁制止器 Electromagnetic stop device	2
可垂直或倾斜安装 Vertical or inclined installation	3
连接变频器 Connected converter	2

备注Note:

1-标准装配选项
1-Standard option

2-非标准常用选项
2-Non-standard option

3-限制性选项，选择时应与制造商确认
3-Restrained option, contact manufacturer if needed

DM/DMX138电动滚筒 DM/DMX138 DRUM MOTOR

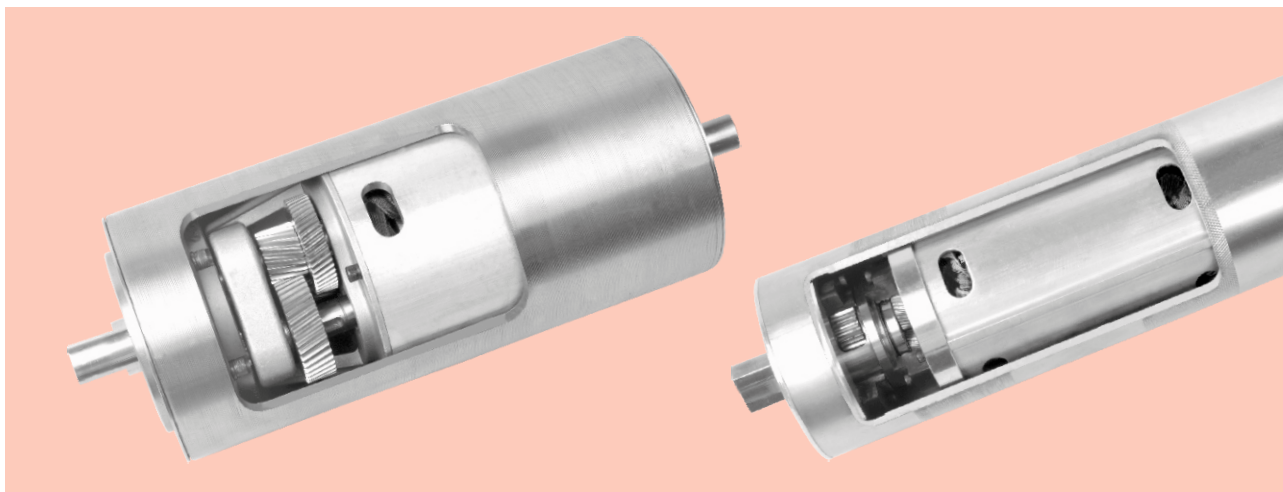

产品信息 Product Information

以高效率、大功率且运转平稳而著称的DM/DMX138电动滚筒，此款电动滚筒的功率和速度范围很广，是名副其实的全能型电机。DM/DMX138 electric drum, which is famous for its high efficiency, high power and stable operation, is a very wide range of power and speed.

- | | |
|-------------------|--|
| • 高负载循环输送机 | High load cycling conveyor |
| • 食品加工工业 | Food processing industry |
| • 制药行业 | Pharmaceutical industry |
| • 肉禽加工业 | Meat processing industry |
| • 皮带输送机 | Belt conveyor |
| • 机场行李处理系统 | Airport baggage handling system |
| • 安检机 | Security machine |
| • 邮政分拣 | Postal sorting |
| • 物流应用 | Logistics application |
| • 干燥、潮湿及需要冲洗的应用环境 | Dry, wet and need to develop the application environment |

DM/DMX138电动滚筒特征 DM/DMX138 Characteristics Of Drum Motor

● 筒体 Drum Shell

- 标准筒体为低碳钢材质，成品表面镀锌，做环保标志 • 食品级筒体为304不锈钢 • 标准筒体表面加工有防滑滚花
- Material of standard drum shell is mild steel, zinc plated, with ECO mark • Food grade shell is 304 stainless steel • Standard cylinder surface processing with non slip roller

● 齿轮传动 Gear Drive

- 高合金钢精磨齿轮，确保传动时超低噪音，铸铝齿轮箱 • 重载型电动滚筒采用行星齿轮传动，根据重型载荷设计，高扭矩传输
- High alloy steel grinding gear, to ensure the transmission of ultra low noise, aluminum gear box • Heavy load electric roller adopts planetary gear transmission, according to heavy load design, high torque transmission

● 电机 Motor

- 频率在50Hz或60Hz时，适用于全球各种通用电压 • 电机绝缘等级F级 • 所有电机附加过热保护器 • 电机油浸式散热 • 电缆出线式，电缆的标准长度1.2米
- When 50Hz or 60Hz is used, it can be applied to all kinds of universal voltage • Motor insulation class F • All motor additional overheat protector • Oil immersed motor cooling
- Cable outlet type, cable length of 1.2M

● 密封等级 Seal Level

- 轴端采用双密封设计 • 电动滚筒的密封防护等级为IP66/IP67
- Double seal design for shaft end • Drum motor sealing protection level is IP66/IP67

● 注油 Oiling

- 电动滚筒出厂前都已按标准注油 • 每运行5000小时换油一次
- Electric roller factory before has according to the standard oil • Every 5000 hours to run oil change time

● 其他 Other

- 水平安装 • 可以加装电磁制动器，但筒体的最短长度会相应加长 • 带速及筒体长度可按客户要求制作 • 根据客户要求，可制作各种非标准电动滚筒
- Horizontal installation • Can be equipped with electromagnetic brake, but the shortest length of the cylinder will be extended accordingly • Belt speed and tube length can be produced according to customer requirements • According to customer requirements, can produce a variety of non - standard electric roller

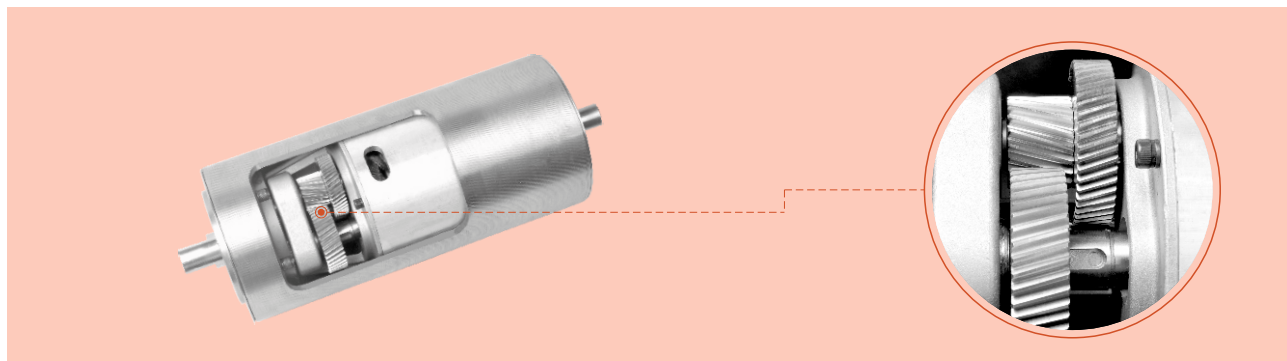

DM138三相轻载滚筒电机机械参数 DM138 Mechanical Parameters Of Three Phase Light Load Drum Motor

P_N kW	np	gs	i	v m/min	n_A min^{-1}	M_A Nm	F_N N	SL _{最小值} mm			
0.18	4	2	12.50	46.82	108.0	19.70	286	300			
			14.81	39.52	91.20	23.30	338	300			
			20.63	28.37	65.40	32.50	471	300			
		3	25.60	22.68	52.70	38.10	552	300			
			30.34	19.29	44.50	45.10	654	300			
			35.09	16.68	38.50	52.20	757	300			
			39.39	14.86	34.30	58.60	850	300			
			48.87	11.98	27.60	72.70	1054	300			
			63.40	9.230	21.30	94.30	1368	300			
			70.99	8.240	19.00	105.6	1531	300			
0.37	2	2	12.50	97.11	224.0	14.10	204	300			
			14.81	81.97	189.1	16.70	241	300			
			20.63	58.84	135.7	23.20	336	300			
		3	25.60	47.42	109.4	27.20	394	300			
			30.34	40.01	92.30	32.20	467	300			
			35.09	34.59	79.80	37.30	540	300			
			39.39	30.82	71.10	41.80	606	300			
			48.87	24.84	57.30	51.90	752	300			
			63.40	19.15	44.20	67.30	976	300			
			70.99	17.10	39.40	75.40	1093	300			
0.55	4	2	12.50	46.82	108.0	43.30	628	300			
			14.81	39.52	91.20	51.30	745	300			
			20.63	28.37	65.40	71.50	1037	300			
		3	25.60	22.86	52.70	83.80	1215	300			
			30.34	19.29	44.50	99.30	1440	300			
			35.09	16.68	38.50	114.9	1665	300			
			0.75	2	2	12.50	97.11	224.0	28.50	413	350
						14.81	81.97	189.1	33.80	490	350
						20.63	58.84	135.7	47.00	682	350
					3	25.60	47.42	109.4	55.10	799	350
30.34	40.01	92.30				65.30	947	350			
35.09	34.59	79.80				75.50	1095	350			
39.39	30.82	71.10				84.80	1229	350			
48.87	24.84	57.30				105.2	1525	350			

P_N : 额定功率 Rated power

i: 减速比 Reduction ratio of

M_A : 电动滚筒额定扭矩 Electric drum rated torque

np: 级数 Series

v: 外管额定速率 Outside the rated speed

F_N : 牵引力 Traction force

gs: 齿轮级数 Gear series

n_A : 外管额定转速 Outer tube rated speed

SL_{最小值}: 最短外管长度 The shortest outer tube length

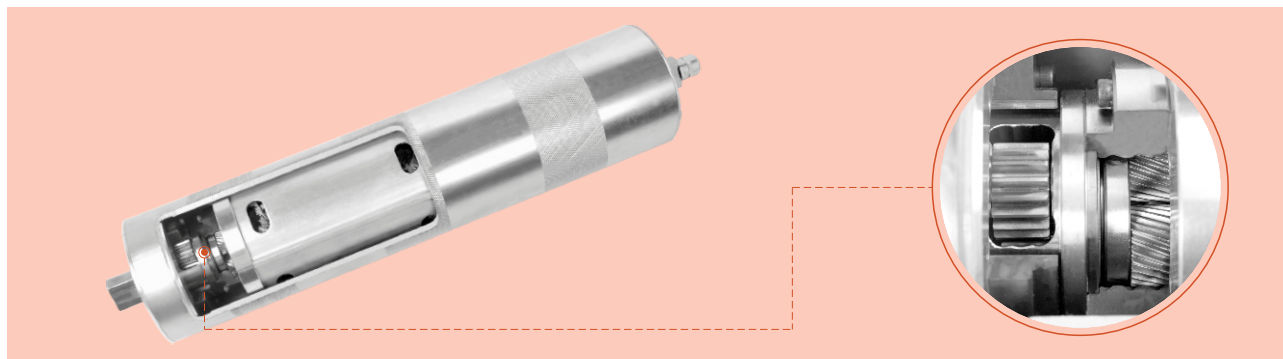

DMX138三相重载滚筒电机机械参数 DMX138 Mechanical Parameters Of Three Phase Heavy Load Drum Motor

P_N kW	np	gs	i	v m/min	n_A min^{-1}	M_A Nm	F_N N	SL _{最小值} mm
0.37	4	2	9.860	48.63	137.0	19.30	340	300
			12.01	39.91	112.4	23.60	415	300
			15.26	31.41	88.50	30.00	527	300
			17.63	27.18	76.60	34.60	609	300
			20.99	22.84	49.30	41.20	725	300
			24.66	19.44	54.80	48.40	852	300
			27.38	17.50	49.30	53.70	946	300
			30.82	15.55	43.80	60.50	1065	300
			36.07	13.29	37.40	70.80	1246	300
			39.70	12.07	34.00	77.90	1372	300
			49.62	9.660	27.20	97.40	1714	300
0.55	2	2	9.860	100.86	284.1	13.90	244	300
			12.01	82.77	233.2	16.90	297	300
			15.26	65.15	183.5	21.50	378	300
			17.63	56.37	158.8	24.80	437	300
			20.99	47.36	133.4	29.50	520	300
			24.66	40.31	113.6	34.70	611	300
			27.38	36.31	102.3	38.50	678	300
			30.82	32.25	90.90	43.40	763	300
			36.07	27.55	77.60	50.80	893	300
			39.70	25.04	70.50	55.90	983	300
			49.62	20.03	56.40	69.80	1229	300
0.75	4	2	9.860	48.63	137.0	39.20	690	350
			12.01	39.91	112.4	47.80	841	350
			15.26	31.41	88.50	60.70	1068	350
			17.63	27.18	76.60	70.20	1235	350
			20.99	22.84	64.30	83.50	1470	350
			24.66	19.44	54.80	98.10	1727	350
			27.38	17.50	49.30	108.9	1917	350
			30.82	15.55	43.80	122.6	2158	350
			36.07	13.29	37.40	143.5	2526	350
			39.70	12.07	34.00	158.0	2780	350
1.10	2	2	9.860	100.86	284.1	27.70	488	350
			12.01	82.77	233.2	33.80	595	350
			15.26	65.15	183.5	42.90	756	350
			17.63	56.37	158.8	49.60	873	350
			20.99	47.36	133.4	59.10	1039	350
			24.66	40.31	113.6	69.40	1221	350
			27.38	36.31	102.3	77.00	1356	350
			30.82	32.25	90.90	86.70	1526	350
			36.07	27.55	77.60	101.5	1786	350
			39.70	25.04	70.50	111.7	1966	350
			49.62	20.03	56.40	139.6	2457	350

P_N : 额定功率 Rated power

i: 减速比 Reduction ratio of

M_A : 电动滚筒额定扭矩 Electric drum rated torque

np: 级数 Series

v: 外管额定速率 Outside the rated speed

F_N : 牵引力 Traction force

gs: 齿轮级数 Gear series

n_A : 外管额定转速 Outer tube rated speed

SL_{最小值}: 最短外管长度 The shortest outer tube length

DM/DMX138外形图 DM/DMX138 Outlining Dimensions

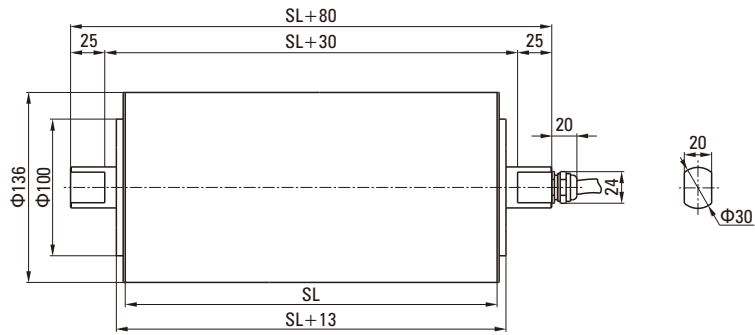

标准的滚筒长度和重量 Standard Drum Length And Weight:															
外管长度 SL单位: mm Outer Tube Length SL Unit: mm	300	350	400	450	500	550	600	650	700	750	800	850	900		
平均重量 单位: Kg Average Weight Unit: Kg	14.5	15.7	16.9	18.1	19.3	20.5	21.7	22.9	24.1	25.3	26.5	27.7	28.9		
最大功率 (kW) Maximum Power (kW)	4P	0.75													
	2P	1.10													
最大速比 Slowest Ratio	71.88														
最小速比 Minimum Speed Ratio	9.86														

DM/DMX138安装图 DM/DMX138 Installation Diagram

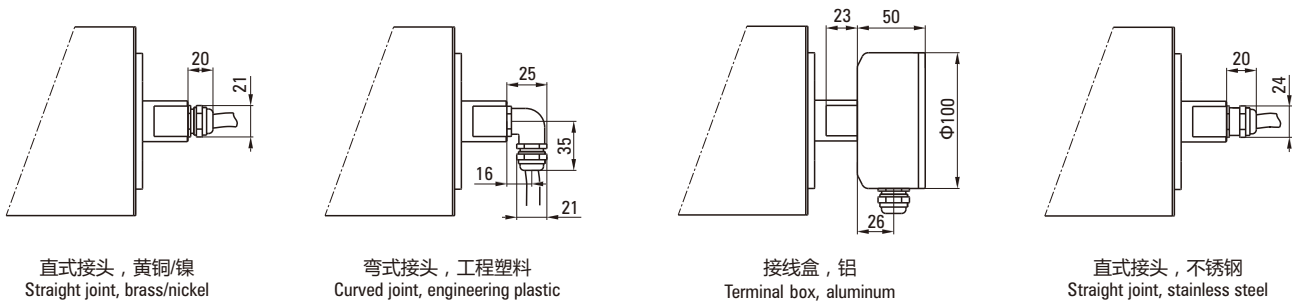

直式接头, 黄铜/镍
Straight joint, brass/nickel

弯式接头, 工程塑料
Curved joint, engineering plastic

接线盒, 铝
Terminal box, aluminum

直式接头, 不锈钢
Straight joint, stainless steel

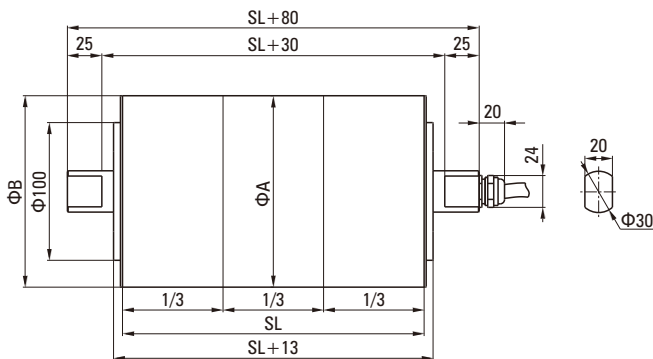

类型 Type	ΦA mm	ΦB mm
138i冠状外管 138i tube	138	136
138i圆柱形外管 138i cylindrical tube	138	138
138i圆柱形外管+键 138i cylindrical tube + key	138	138

DM/DMX138选项表-电动滚筒 DM/DMX138 Option - Drum Motor

部件说明 Component Description	电动滚筒 Drum Motor
筒体 Barrel	
碳钢冠状筒体 Carbon steel tube body	1
碳钢直式筒体 Carbon steel tubular	2
不锈钢 (标准304) 冠状筒体 Stainless steel (standard 304) coronal tube body	2
不锈钢 (标准304) 直式筒体 Stainless steel (standard 304) straight tube	2
特殊冠状及凹槽型 Special coronal and groove type	3
前后端盖 Front end cover	
铸铝端盖 Cast aluminum cover	1
镀镍铸铝端盖 Nickel plated aluminum cover	2
不锈钢 (标准304) 端盖 Stainless steel (standard 304) end cover	2
前后轴 Antero posterior axis	
碳钢轴 Carbon steel shaft	1
不锈钢轴 Stainless steel shaft	2
电机 Motor	
单相或三相异步电动机 Single phase or three phase asynchronous motor	1
电压1*220V/50Hz或3*380V/50Hz Voltage 1*220V/50Hz or 3*380V/50Hz	1
50Hz或60Hz条件下的全球通用电压 Global common voltage under 50Hz or 60Hz conditions	1
加装电机过热保护器 Motor overheat protector	1
低温环境用油 Low temperature environment	2
食品级油&脂 (FDA和USDA) Food grade oil & fat (FDA and USDA)	2
电气连接 Electrical connection	
不锈钢弯头 Stainless steel elbow	3
直弯式出线 Straight curved line	1
PVC线缆 PVC cable	1
低烟无卤素线缆 Low smoke halogen free cable	2
铸铝端子盒 Cast terminal box	1
镀镍铸铝端子盒 Nickel plated aluminum terminal box	1
不锈钢端子盒 Stainless steel terminal box	1
其他选项 Sidebar	
电磁制动器 Electromagnetic stop device	2
可垂直或倾斜安装 Vertical or inclined installation	3
连接变频器 Connected converter	2

备注Note:

1-标准装配选项
1-Standard option

2-非标准常用选项
2-Non-standard option

3-限制性选项，选择时应与制造商确认
3-Restrained option, contact manufacturer if needed

DM/DMX165电动滚筒 DM/DMX165 DRUM MOTOR

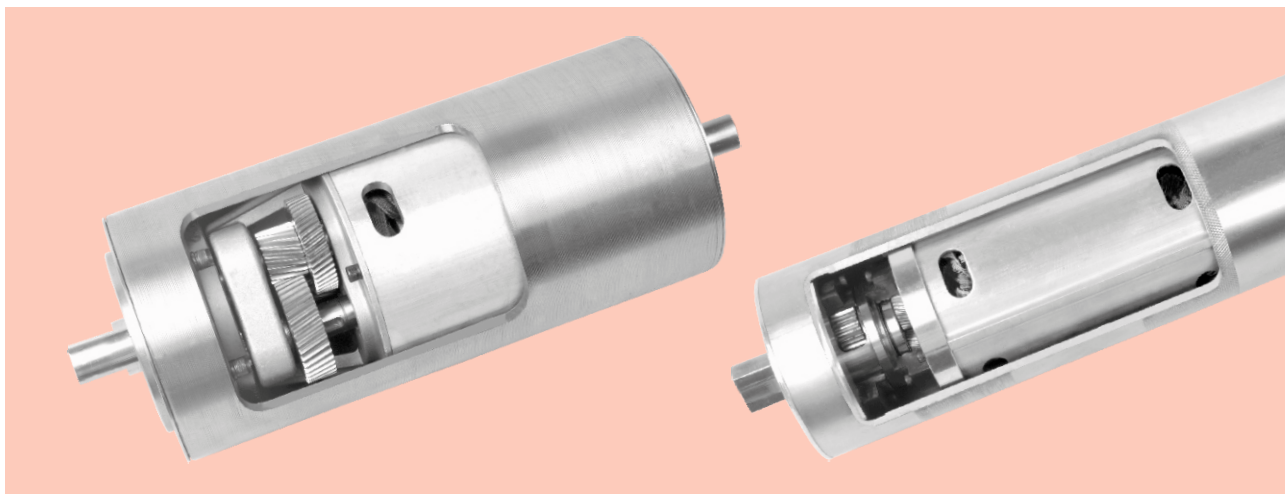

产品信息 Product Information

此款电动滚筒非常强健扎实，能够承受巨大的扭矩和很高的径向负载，具有外形兼顾、耐冲击和扭矩强劲等显著特点，可以选择较大负载输送设备的最佳选择。

The electric roller is very robust and can withstand great torque and high radial load. It has the advantages of high profile, high impact and high torque, and can choose the best choice of load transmission equipment.

- | | |
|-------------------|--|
| • 食品加工输送机 | Food processing conveyer |
| • 机场行李处理系统 | Airport baggage handling systems |
| • 包装输送机 | Packing conveyer |
| • 皮带秤 | Belt balance |
| • 邮政分拣输送机 | Post sorting conveyer |
| • 钢或塑料模组网带应用 | Steel or plastic module mesh belt application |
| • 农作物 | Crops |
| • 干燥、潮湿及需要冲洗的应用环境 | Dry, wet and need to develop the application environment |

DM/DMX165电动滚筒特征 DM/DMX165 Characteristics Of Drum Motor

● 筒体 Drum Shell

- 标准筒体为低碳钢材质，成品表面镀锌，做环保标志 • 食品级筒体为304不锈钢 • 标准筒体表面加工有防滑滚花
- Material of standard drum shell is mild steel, zinc plated, with ECO mark • Food grade shell is 304 stainless steel • Standard cylinder surface processing with non slip roller

● 齿轮传动 Gear Drive

- 高合金钢精磨齿轮，确保传动时超低噪音，铸铝齿轮箱 • 重载型电动滚筒采用行星齿轮传动，根据重型载荷设计，高扭矩传输
- High alloy steel grinding gear, to ensure the transmission of ultra low noise, aluminum gear box • Heavy load electric roller adopts planetary gear transmission, according to heavy load design, high torque transmission

● 电机 Motor

- 频率在50Hz或60Hz时，适用于全球各种通用电压 • 电机绝缘等级F级 • 所有电机附加过热保护器 • 电机油浸式散热 • 电缆出线式，电缆的标准长度1.2米
- When 50Hz or 60Hz is used, it can be applied to all kinds of universal voltage • Motor insulation class F • All motor additional overhear protector • Oil immersed motor cooling
- Cable outlet type, cable length of 1.2M

● 密封等级 Seal Level

- 轴端采用双密封设计 • 电动滚筒的密封防护等级为IP66/IP67
- Double seal design for shaft end • Drum motor sealing protection level is IP66/IP67

● 注油 Oiling

- 电动滚筒出厂前都已按标准注油 • 每运行5000小时换油一次
- Electric roller factory before has according to the standard oil • Every 5000 hours to run oil change time

● 其他 Other

- 水平安装 • 可以加装电磁制动器，但筒体的最短长度会相应加长 • 带速及筒体长度可按客户要求制作 • 根据客户要求，可制作各种非标准电动滚筒
- Horizontal installation • Can be equipped with electromagnetic brake, but the shortest length of the cylinder will be extended accordingly • Belt speed and tube length can be produced according to customer requirements • According to customer requirements, can produce a variety of non - standard electric roller

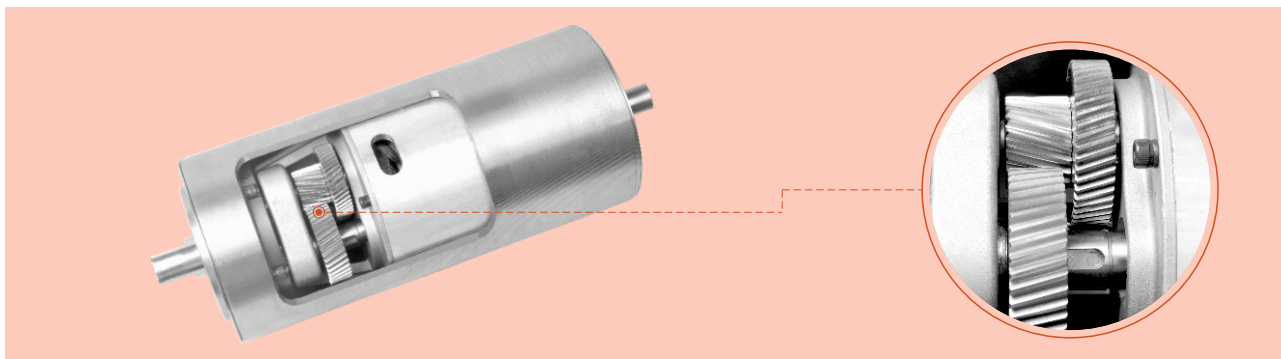

DM165三相轻载滚筒电机机械参数 DM165 Mechanical Parameters Of Three Phase Light Load Drum Motor

P_N kW	np	gs	i	v m/min	n_A min^{-1}	M_A Nm	F_N N	SL _{最小值} mm
0.37	4	2	12.35	57.57	111.7	28.20	342	400
			15.06	47.21	91.60	34.40	417	400
			20.04	35.48	68.90	45.70	554	400
		3	24.30	29.26	56.80	52.30	634	400
			31.70	22.43	43.50	68.30	828	400
			39.17	18.15	35.20	84.40	1023	400
			46.16	15.40	29.90	99.40	1205	400
0.55	4	2	12.35	56.32	109.3	42.80	519	400
			15.06	46.19	89.60	52.20	633	400
			20.04	34.71	67.40	69.50	842	400
		3	39.17	17.76	34.50	135.8	1646	400
			46.16	15.07	29.20	160.0	1940	400
			61.96	11.23	21.80	214.8	2604	400
			0.75	4	2	12.35	56.32	109.3
15.06	46.19	89.60				71.20	863	400
20.04	34.71	67.40				94.70	1148	400
3	24.30	28.62			55.60	108.5	1315	400
	31.70	21.94			42.60	141.5	1715	400
	39.17	17.76			34.50	174.8	2119	400
	46.16	15.07			29.20	206.0	2497	400
1.10	2	2	9.470	153.42	297.8	31.40	381	400
			12.35	117.65	228.3	41.00	497	400
			15.06	96.48	187.3	50.00	606	400
		3	20.04	72.50	140.7	66.50	806	400
			24.30	59.79	116.0	76.10	923	400
			31.70	45.83	89.00	99.30	1204	400
			39.17	37.09	72.00	122.7	1488	400
	4	2	46.16	31.48	61.10	144.7	1753	400
			12.35	56.32	109.3	85.60	1038	400
			15.06	46.19	89.60	104.4	1266	400
		3	20.04	34.71	67.40	139.0	1684	400
			24.30	28.62	55.60	159.1	1928	400
			31.70	21.94	42.60	207.5	2515	400
			39.17	17.76	34.50	256.4	3108	400
1.50	4	2	46.16	15.07	29.20	302.2	3663	400
			12.35	57.57	111.7	114.2	1385	400
			15.06	47.21	91.60	139.3	1689	400
		3	20.04	35.48	68.90	185.4	2247	400
			24.30	29.26	56.80	212.2	2572	400
			31.70	22.43	43.50	276.8	3355	400
			2	2	9.470	153.42	297.8	62.90
	12.35	117.65			228.3	82.00	994	400
	15.06	96.48			187.3	100.0	1212	400
	3	20.04		72.50	140.7	133.1	1613	400
		24.30		59.79	116.0	152.3	1846	400
		31.70		45.83	89.00	198.7	2408	400
		39.17		37.09	72.00	245.5	2976	400
	2.20	2	2	46.16	31.48	61.10	289.3	3507
12.35				57.57	111.7	114.2	1385	400
15.06				47.21	91.60	139.3	1689	400
3			20.04	35.48	68.90	185.4	2247	400
			24.30	29.26	56.80	212.2	2572	400
			31.70	22.43	43.50	276.8	3355	400
			2	2	9.470	153.42	297.8	62.90
12.35		117.65			228.3	82.00	994	400
15.06		96.48			187.3	100.0	1212	400
3		20.04		72.50	140.7	133.1	1613	400
		24.30		59.79	116.0	152.3	1846	400
		31.70		45.83	89.00	198.7	2408	400
		39.17		37.09	72.00	245.5	2976	400

P_N : 额定功率 Rated power

i: 减速比 Reduction ratio of

M_A : 电动滚筒额定扭矩 Electric drum rated torque

np: 级数 Series

v: 外管额定速率 Outside the rated speed

F_N : 牵引力 Traction force

gs: 齿轮级数 Gear series

n_A : 外管额定转速 Outer tube rated speed

SL_{最小值}: 最短外管长度 The shortest outer tube length

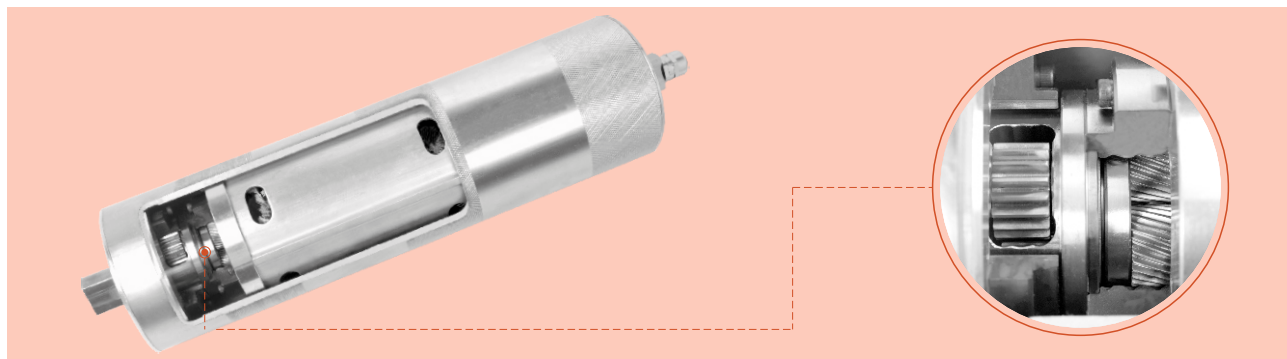

DMX165三相重载滚筒电机机械参数 DMX165 Mechanical Parameters Of Three Phase Heavy Load Drum Motor

P_N kW	np	gs	i	v m/min	n_A min^{-1}	M_A Nm	F_N N	SL _{最小值} mm
0.55	4	2	9.860	48.63	137.0	28.80	506	380
			12.01	39.91	112.4	35.00	617	380
			15.26	31.41	88.50	44.50	784	380
			17.63	27.18	76.60	51.50	906	380
			20.99	22.84	64.30	61.20	1078	380
			24.66	19.44	54.80	71.90	1266	380
			27.38	17.50	49.30	79.90	1406	380
			30.82	15.55	43.80	89.90	1583	380
			36.07	13.29	37.40	105.3	1853	380
			39.70	12.07	34.00	115.8	2039	380
			49.62	9.660	27.20	144.8	2549	380
0.75	4	2	9.860	48.63	137.0	39.20	690	380
			12.01	39.91	112.4	47.80	841	380
			15.26	31.41	88.50	60.70	1068	380
			17.63	27.18	76.60	70.20	1235	380
			20.99	22.84	64.30	83.50	1470	380
			24.66	19.44	54.80	98.10	1727	380
			27.38	17.50	49.30	108.9	1917	380
			30.82	15.55	43.80	122.6	2158	380
			36.07	13.29	37.40	143.5	2526	380
			39.70	12.07	34.00	158.0	2780	380
			49.62	9.66	27.20	197.5	3475	380
1.10	2	2	9.860	100.86	284.1	27.70	488	380
			12.01	82.77	233.2	33.80	595	380
			15.26	65.15	183.5	42.90	756	380
			17.63	56.37	158.8	49.60	873	380
			20.99	47.36	133.4	59.10	1039	380
			24.66	40.31	113.6	69.40	1221	380
			27.38	36.31	102.3	77.00	1356	380
			30.82	32.25	90.90	86.70	1526	380
			36.07	27.55	77.60	101.5	1786	380
			39.70	25.04	70.50	111.7	1966	380
			49.62	20.03	56.40	139.6	2457	380
1.50	4	2	9.860	48.63	137.0	78.40	1380	380
			12.01	39.91	112.4	95.60	1682	380
			15.26	31.41	88.50	121.4	2137	380
			17.63	27.18	76.60	140.3	2470	380
			20.99	22.84	64.30	167.0	2940	380
			24.66	19.44	54.80	196.2	3453	380
			27.38	17.50	49.30	217.9	3835	380
			30.82	15.55	43.80	245.3	4317	380
			36.07	13.29	37.40	287.1	5052	380
						9.860	100.86	284.1
2.20	2	2	12.01	82.77	233.2	67.60	1189	380
			15.26	65.15	183.5	85.90	1511	380
			17.63	56.37	158.8	99.20	1747	380
			20.99	47.36	133.4	118.1	2079	380
			24.66	40.31	113.6	138.8	2442	380
			27.38	36.31	102.3	154.1	2712	380
			30.82	32.25	90.90	173.4	3053	380
			36.07	27.55	77.60	203.0	3573	380
			39.70	25.04	70.50	223.4	3932	380
						49.62	20.03	56.40

P_N : 额定功率 Rated power

i: 减速比 Reduction ratio of

M_A : 电动滚筒额定扭矩 Electric drum rated torque

np: 级数 Series

v: 外管额定速率 Outside the rated speed

F_N : 牵引力 Traction force

gs: 齿轮级数 Gear series

n_A : 外管额定转速 Outer tube rated speed

SL_{最小值}: 最短外管长度 The shortest outer tube length

DM/DMX165外形图 DM/DMX165 Outlining Dimensions

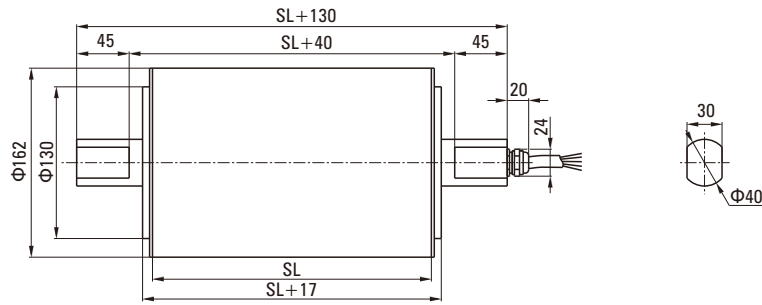

标准的滚筒长度和重量 Standard Drum Length And Weight:

外管长度 SL单位: mm Outer Tube Length SL Unit: mm	400	450	500	550	600	650	700	750	800	850	900	950	1000
平均重量 单位: Kg Average Weight Unit: Kg	35.0	37.0	38.8	40.7	42.6	44.5	46.4	48.3	50.2	52.1	54.0	55.9	57.8
最大功率 (kW) Maximum Power (kW)	4P						1.5						
	2P						2.2						
最大速比 Slowest Ratio							61.96						
最小速比 Minimum Speed Ratio							9.86						

DM/DMX165安装图 DM/DMX165 Installation Diagram

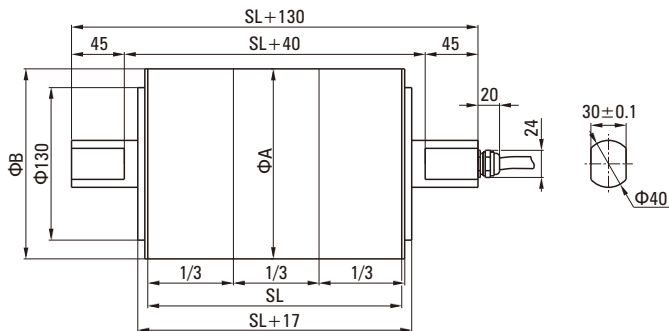
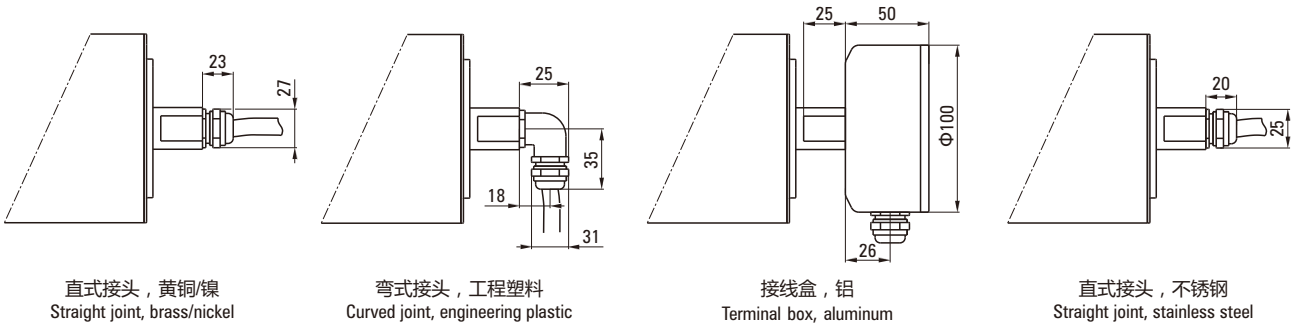

类型 Type	ΦA mm	ΦB mm
165i冠状外管 165i tube	164	162
165i圆柱形外管 165i cylindrical tube	164	164
165i圆柱形外管+键 165i cylindrical tube + key	164	164

DM/DMX165选项表-电动滚筒 DM/DMX165 Option - Drum Motor

部件说明 Component Description	电动滚筒 Drum Motor
筒体 Drum shell	
碳钢冠状筒体 Carbon steel tube body	1
碳钢直式筒体 Carton steel straight drum	2
不锈钢 (标准304) 冠状筒体 Stainless steel (standard 304) coronal tube body	2
不锈钢 (标准304) 直式筒体 Stainless steel (standard 304) straight drum	2
特殊冠状及凹槽型 Special coronal and groove type	3
前后端盖 Front end cover	
铸铝端盖 Cast aluminum cover	1
镀镍铸铝端盖 Nickel plated aluminum cover	2
不锈钢 (标准304) 端盖 Stainless steel (standard 304) end cover	2
前后轴 Front and rare shaft	
碳钢轴 Carbon steel shaft	1
不锈钢轴 Stainless steel shaft	2
电机 Motor	
单相或三相异步电动机 Single phase or three phase asynchronous motor	1
电压1*220V/50Hz或3*380V/50Hz Voltage 1*220V/50Hz or 3*380V/50Hz	1
50Hz或60Hz条件下的全球通用电压 Global common voltage under 50Hz or 60Hz conditions	1
加装电机过热保护器 Thermal protector	1
低温环境用油 Low temperature environment	2
食品级油&脂 (FDA和USDA) Food grade oil & fat (FDA and USDA)	2
电气连接 Electrical connection	
不锈钢弯头 Stainless steel elbow	3
直弯式出线 Straight curved line	1
PVC线缆 PVC cable	1
低烟无卤素线缆 Low smoke halogen free cable	2
铸铝端子盒 Cast terminal box	1
镀镍铸铝端子盒 Nickel plated aluminum terminal box	1
不锈钢端子盒 Stainless steel terminal box	1
其他选项 Other options	
电磁制止器 Electromagnetic stop device	2
可垂直或倾斜安装 Vertical or inclined installation	3
连接变频器 Connected converter	2

备注Note:

1-标准装配选项
1-Standard option

2-非标准常用选项
2-Non-standard option

3-限制性选项，选择时应与制造商确认
3-Restrained option, contact manufacturer if needed

接线图 WIRING DIAGRAM

缩写目录：Abbreviated Directory:

TC: 恒温保护 Constant temperature protection
BR: 制动器(可选) Brake (optional)

1~: 单相电机 Single-phase machine
3~: 三相电机 Three-phase machine

Cr: 运行电容器 Running capacitor
Cs: 起动电容器 Start capacitor

电缆出线 Cable Outlet

● 单相电机带热保护控制7根引出线 Single Phase Motor With Thermal Protection Control Of 7 Lead Wire

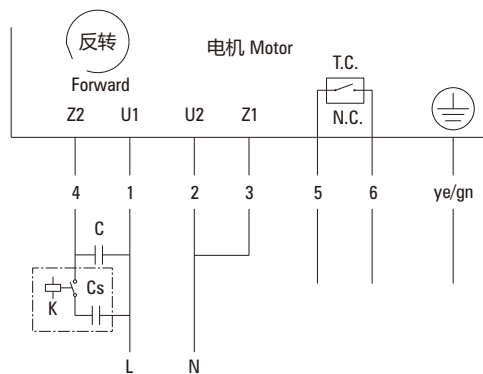
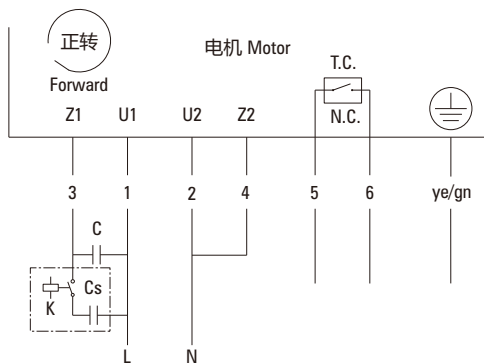

● 单相电机带电磁制动带热保护器9根引出线 Single Phase Motor With Electromagnetic Brake With Heat Protector 9 Lead Wire

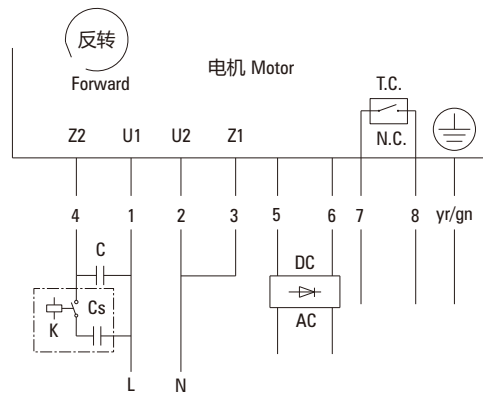
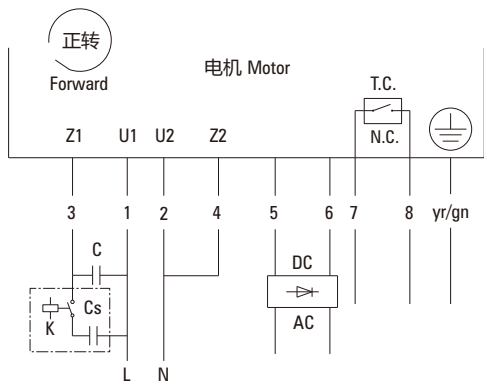

● 三相电机带热保护控制6根引出线 Three Phase Motor With Thermal Protection Control Of 6 Wire

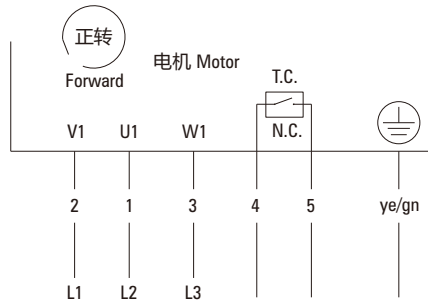
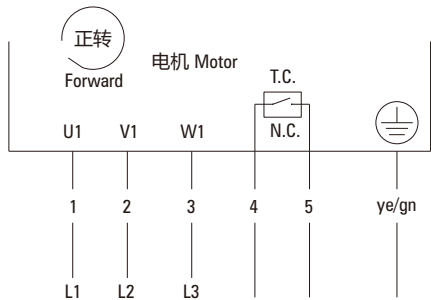

● 三相电机带电磁制动器带过热保护器8根出线
Three Phase Motor With Electromagnetic Brake With Over 8 Outlet

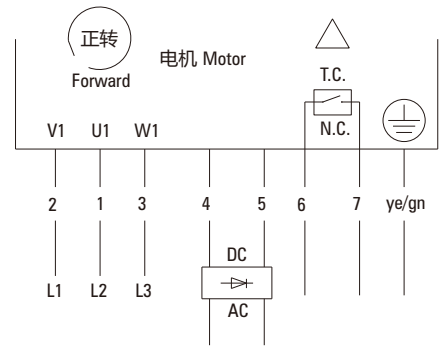
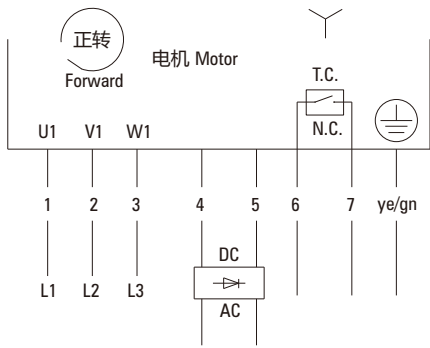

● 三相电机带过热保护器9根出线
Three Phase Motor With Over 9 Outlet

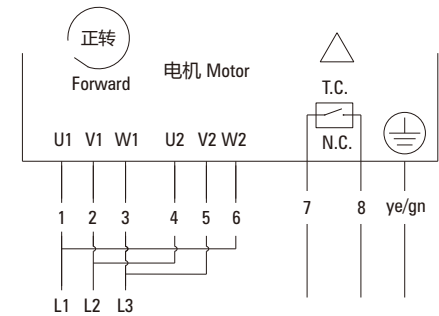
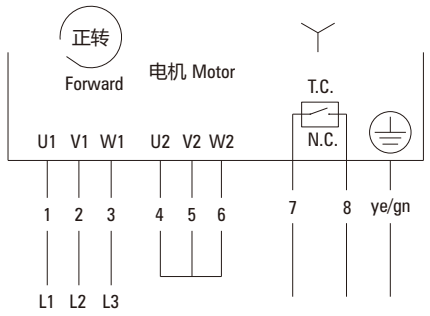

● 三相电机带电磁制动器带过热保护器11根出线
Three Phase Motor With Electromagnetic Brake With Over 11 Outlet

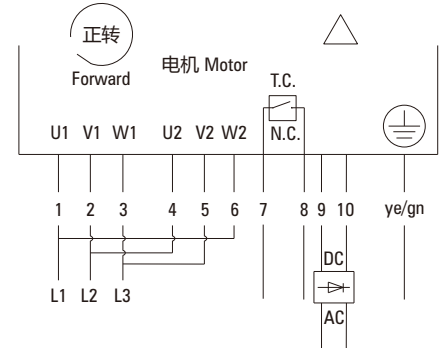
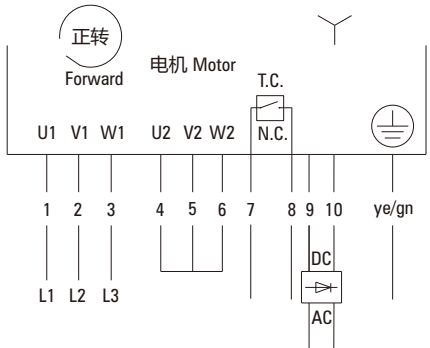

● 三相电机带电磁制动器11根出线
Three Phase Motor With Electromagnetic Brake 11 Outlet

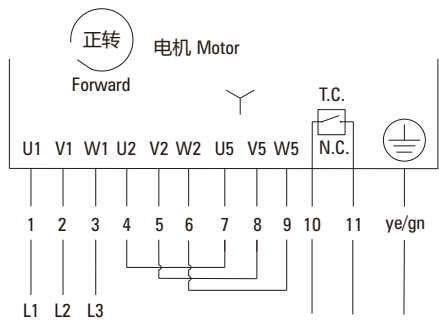
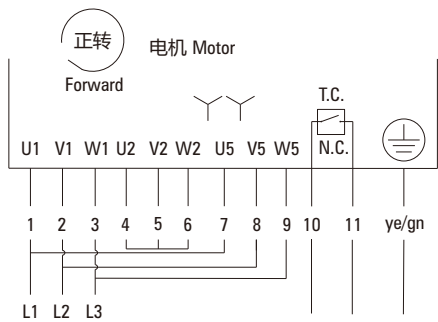

注 Notes:
三角形连接: 低电压
Triangular connection: low voltage

P星形连接: 高电压
P star connection: high voltage

P双星形: 低电压
P binary form: low voltage

接线图 WIRING DIAGRAM

缩写目录：Abbreviated Directory:

TC: 恒温保护 Constant temperature protection
BR: 制动器(可选) Brake (optional)

1~: 单相电机 Single-phase machine
3~: 三相电机 Three-phase machine

Cr: 运行电容器 Running capacitor
Cs: 起动电容器 Start capacitor

接线盒出线 Junction Box

● 单相电机带过热保护器7根引线 Single Phase Motor With Over 7 Lead Wire

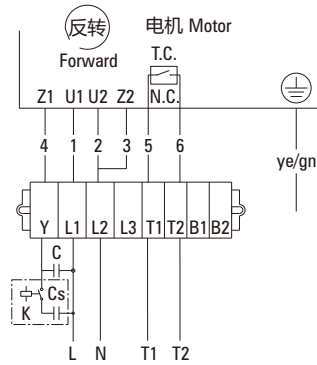
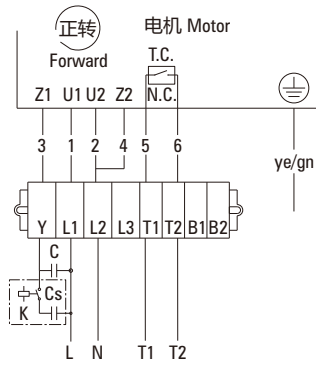

● 单相电机带电磁制动器和过热保护器9根引线 Single Phase Motor With Electromagnetic Brake And Overheat Protector 9 Lead Wire

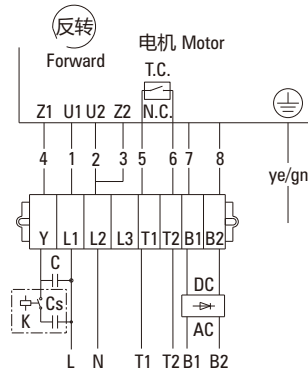
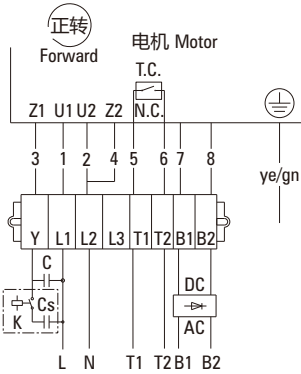

● 三相电机带过热保护器6根引线 Three Phase Motor With Over 6 Lead Wire

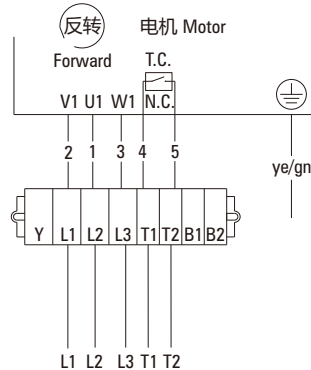
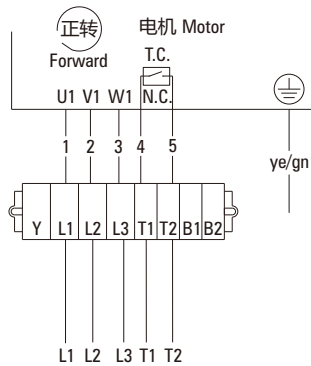

● 三相电机带电磁制动器带过热保护器8根引线
Three Phase Motor With Electromagnetic Brake With Over 8 Lead Wire

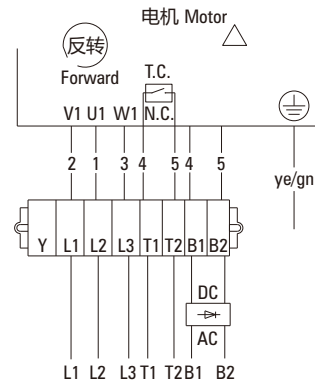
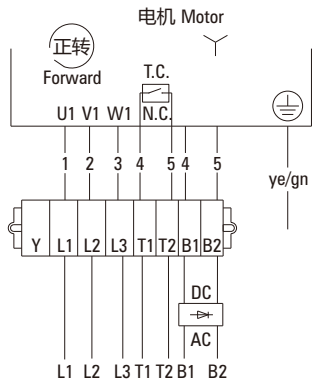

● 三相电机带过热保护器9根引线
Three Phase Motor With Over 9 Lead Wire

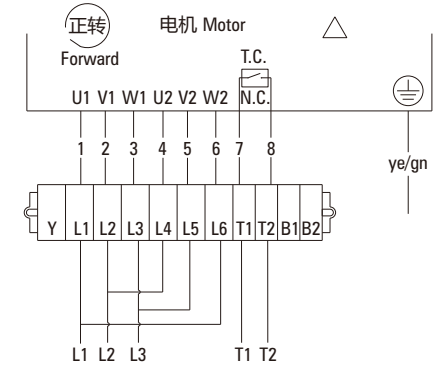
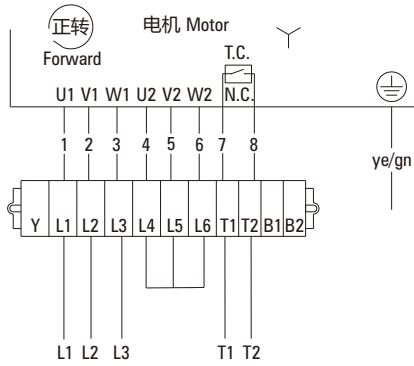

● 三相电机带电磁制动器带过热保护器11根引线
Three Phase Motor With Electromagnetic Brake With Over 11 Lead Wire

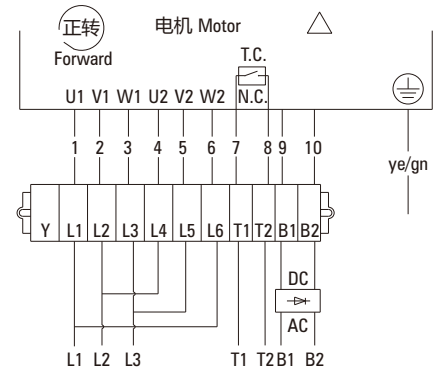
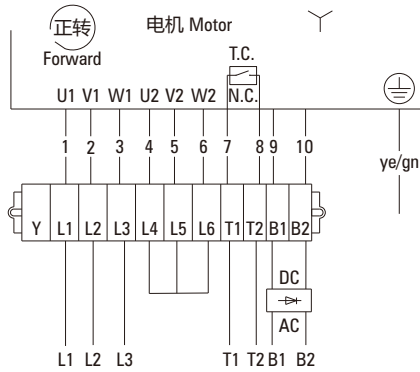

● 三相电机带过热保护器12根引线
Three Phase Motor With Over 12 Lead Wire

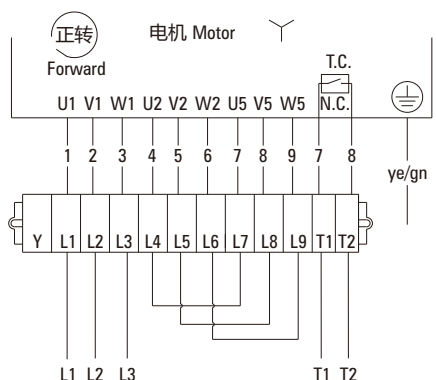
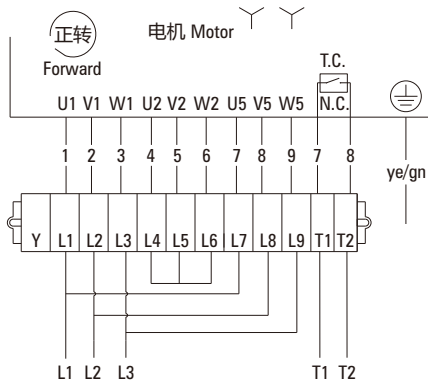

注 Notes:

三角形连接: 低电压
Triangular connection: low voltage

P星形连接: 高电压
P star connection: high voltage

P双星形: 低电压
P binary form: low voltage